

Enabling Switches ZS



EUCHNER

More than safety.

EUCHNER

More than safety.



Headquarters in Leinfelden-Echterdingen



Logistics center in Leinfelden-Echterdingen



Production location in Unterböhringen

Internationally successful – the EUCHNER company

EUCHNER GmbH + Co. KG is a world-leading company in the area of industrial safety technology. EUCHNER has been developing and producing high-quality switching systems for mechanical and systems engineering for more than 60 years.

The medium-sized family-operated company based in Leinfelden, Germany, employs around 750 people around the world.

18 subsidiaries and other sales partners in Germany and abroad work for our international success on the market.

Quality and innovation – the EUCHNER products

A look into the past shows EUCHNER to be a company with a great inventive spirit. We take the technological and ecological challenges of the future as an incentive for extraordinary product developments.

EUCHNER safety switches monitor safety doors on machines and installations, help to minimize dangers and risks and thereby reliably protect people and processes. Today, our products range from electromechanical and electronic components to intelligent integrated safety solutions. Safety for people, machines and products is one of our dominant themes.

We define future safety technology with the highest quality standards and reliable technology. Extraordinary solutions ensure the great satisfaction of our customers. The product ranges are subdivided as follows:

- ▶ Transponder-coded Safety Switches
- ▶ Transponder-coded Safety Switches with guard locking
- ▶ Multifunctional Gate Box MGB
- ▶ Access management systems (Electronic-Key-System EKS)
- ▶ Electromechanical Safety Switches
- ▶ Magnetically coded Safety Switches
- ▶ Enabling Switches
- ▶ Safety Relays
- ▶ Emergency Stop Devices
- ▶ Hand-Held Pendant Stations and Handwheels
- ▶ Safety Switches with AS-Interface
- ▶ Joystick Switches
- ▶ Position Switches

 **made
in
Germany**

Enabling switches

General	4
About this catalog	4
Standards and approvals	5
Function and technology used in enabling switches	5
Built-in enabling switches ZSE/ZXE	9
Enabling switch ZSM	13
Enabling switches ZSA/ZSB/ZSR	31
Enabling switches ZSA (housing G1)	32
Enabling switches ZSB with additional buttons and LEDs (housing G1)	39
Enabling switches ZSR (housing G2)	41
Enabling switches ZSB with additional buttons and LEDs (housing G3)	43
Enabling devices ZSG/ZSA	49
Built-in enabling device ZSG	50
Enabling devices ZSA (housing G1)	51
Kits	53
Kit for enabling switches ZSM	54
Kit for enabling switches ZSA (housing G1)	59
Kit for enabling device ZSA (housing G1)	60
Accessories	61
Holders and components	62
Plug connectors and cables	64
Technical data	69
Wiring diagrams for enabling switches ZSM	70
Technical data for enabling switches ZSM	77
Technical data for enabling switches ZSE/ZXE/ZSA/ZSB/ZSR	79
Technical data, accessories for enabling switches	83
Item index	85
Index by item designation	85
Index by order numbers	87





About this catalog



The Enabling Switch ZS catalog provides an overview of our two-stage enabling devices and three-stage enabling switches. Due to their robust and ergonomic design, these switches are the right choice for numerous applications.

You will find the technical data after the product overview. There is a reference to the page with the related technical data on the pages listing the products.

At the front of the catalog you will find useful information on the topic of enabling switches.

You will find the following series and accessories in this catalog:

Enabling switches, 3-stage					
Enabling switches for building in	Hand-held enabling switches				Accessories
ZSG, ZSE and ZXE	in housing ZSM or as kit	in housing G1 or as kit	in housing G1, G3	in housing G2	Cables, plug connectors, holders, blanking covers
 <p>ZSE</p> <p>ZXE</p>	 <p>ZSM</p>	 <p>ZSA</p> <p>G1</p>	 <p>ZSB</p> <p>G1</p> <p>G3</p>	 <p>ZSR</p> <p>G2</p>	

Enabling devices, 2-stage	
Enabling devices for building in	Hand-held enabling devices
<p>ZSG</p>  <p>ZSG</p>	<p>in housing G1 or as kit</p> <p>ZSA</p>  <p>G1</p>

Standards and approvals

Standards

Enabling switches that are integrated into safety circuits have a safety function. For this reason they are assessed based on the Machinery Directive and the European standards. The Machinery Directive has been implemented in national law in the EU member states and, as a result, is binding for all manufacturers.

Detailed requirements for switches are defined in EN 60947 Part 5-1 (Specification for low-voltage switchgear and controlgear. Part 5-1: Control circuit devices and switching elements. Electromechanical control circuit devices).

If the requirements of these standards are met, conformity with the applicable laws and therefore with the Machinery Directive is assumed. EUCHNER enabling switches comply with the relevant standards for safety switchgear and therefore help you to comply with safety requirements during the design of your machinery.

User standards

As a user, you should take into consideration the following standards of relevance for enabling switches:

European and international standards

standard	Title
EN 60 204	Safety of machinery. Electrical equipment of machines
EN 775/ EN ISO 10218	Robots for industrial environments - safety requirements (ISO 10218:1992, modified)
VDI 2853	Sicherheitstechnische Anforderungen an Bau, Ausrüstung und Betrieb von Industrierobotern [Safety related requirements on design, configuration and operation of industrial robots] (withdrawn)
VDI 2854	Sicherheitstechnische Anforderungen an automatisierte Fertigungssysteme (Safety related requirements on automated manufacturing systems)

American standards

standard	Title
ANSI B11-TR3-2000	Risk Assessment and Risk Reduction - A Guide to Estimate, Evaluate and Reduce Risks Associated with Machine Tools
NFPA 79 (2002)	Electrical Standard for Industrial Machinery
OSHA 29 CFR 1910 Subpart O Subpart P Subpart S	Machinery and Machine Guarding Hand and Portable Power Tools and Other Hand-Held Equipment Electrical

Please also observe any existing C standards!

Approvals

To demonstrate conformity, the Machinery Directive also includes the possibility of type examination. In addition to taking into account all relevant standards, EUCHNER commissions type examinations by a notified body. Many of the enabling switches listed in this catalog have been tested by an employers' liability insurance association (BG) and are given in the lists from the BG.

Furthermore, many enabling switches are listed by the Underwriters Laboratories (UL) and the Canadian Standards Association (CSA). These enabling switches can be used in countries in which this listing is required. The approval symbols on the individual pages of the catalog indicate which body tested the enabling switches.

With the aid of the approval symbols listed below you can quickly see which approvals are available for the related enabling switches:

	Switches with this symbol have the approval of the German Social Accident Insurance association (DGUV) – formerly the employers' liability insurance association (BG).
	Switches with this symbol are approved by Underwriters Laboratories (UL, Canada and USA)

Function and technology used in enabling switches

Task of enabling switches

Enabling switches are manually operated control devices that, together with other control switches, enable commands related to potentially hazardous conditions to be run, as long as the enabling switches are actuated continuously.

These switches are used wherever personnel must work directly in the danger area on machines and systems. This is necessary, e.g. during setting up, programming, testing or servicing work. As per annex 1 of the Machinery Directive, the protective action of movable safety guards can be disabled in these operating modes. The Machinery Directive places the condition that these operating modes must be secured using a lockable device (e.g. key-operated rotary switch) and machine operation is only allowed to be triggered by a second, separate action.

To enable the operator in the danger area of a machine to trigger a machine movement, an enabling device must also be actuated. The operator must also be able to stop the machine movement using the enabling device. This task is performed by the enabling switch.

Every person who is in the hazardous area must carry an enabling device so that suitable action can be taken in case of danger.

Two-stage enabling device or three-stage enabling switch?

The operator can only start a machine movement if he/she actuates the enabling device and keeps it in the actuated position. The movement is stopped again when the switch is released. This two-stage function (OFF-ON) is provided by all enabling switches.

However, experience shows that the operator often clenches the enabling device in an emergency.

In this case a three-stage enabling switch is better and is specifically requested in many C standards. This switch has three switch positions (OFF-ON-OFF) and, if the operator clenches the switch, it is actuated beyond the enabling position (middle position) and the machine is shut down as a result.

If a 2-stage enabling device is used, it must also be ensured that, in an emergency, the operator is in a position to activate an emergency stop device in close proximity (VDI 2853). To identify the type of enabling switch in the catalog, the following symbols are used:

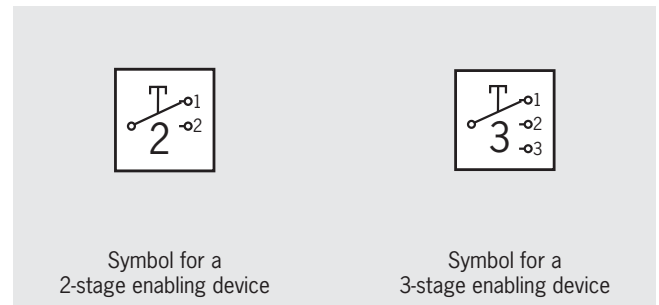

Large selection of switching elements

To be able to cover as many applications as possible, EUCHNER enabling switches can be fitted with various switching elements of single-channel or dual-channel design. Auxiliary contacts are also available, as are additional switches or displays.

Positively driven contacts

Positively driven contacts are used in many switching elements. These are special switching contacts that are designed to ensure the switching contacts are always reliably separated. Even if contacts are welded together, the connection is opened by the actuating force.

Function sequence of two-stage enabling device

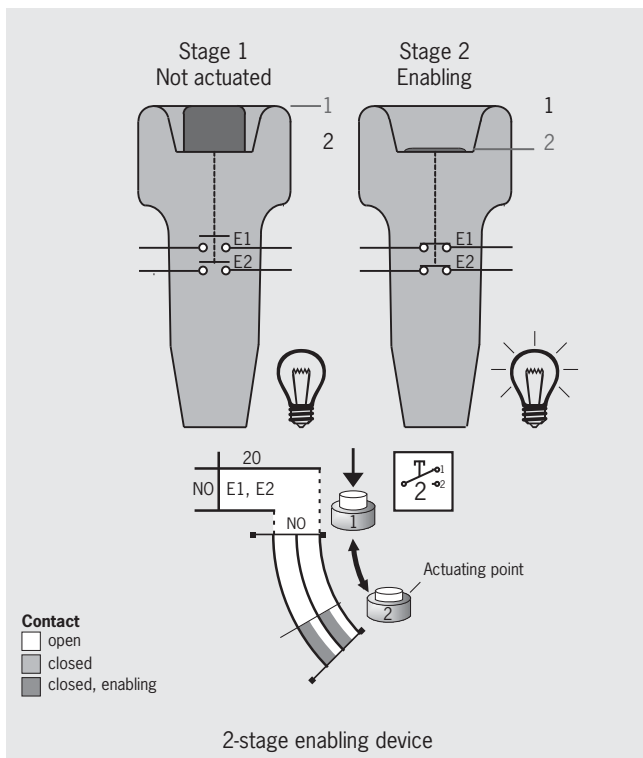

Function sequence of three-stage enabling switch

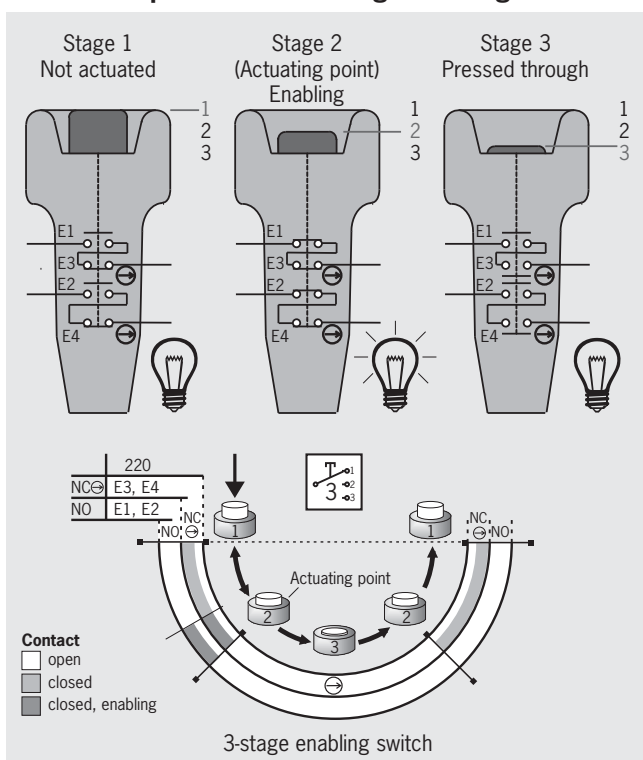

As can be clearly seen in the figure, the enabling function can only be achieved at stage 2. This function is provided by the closing of the normally open contacts (NO = E1 and E2). If the button is released, that is back from stage 2 to stage 1, the normally open contacts are opened again. The 2-stage enabling devices and 3-stage enabling switches are identical in this function.

If, in this example, the button on a 3-stage enabling switch is pressed past the actuating point (stage 2) in panic (to stage 3), then not only the normally open contacts (NO) are reset, but also the safe positively driven contacts.

The patented switch system ensures that the enabling function does not become active at stage 2 on the resetting of the pushbutton from stage 3 to stage 1. In this example the enable can only be given if normally open and positively driven contacts are closed at the same time. This situation is only possible on actuation from stage 1 to stage 2. In the other direction, from stage 3 to stage 1, stage 2 is skipped and unintentional re-starting prevented.

Once the pushbutton has reached stage 1, the function sequence can be started again.

Due to its design, the switch unit also provides a wear-free, constant actuating point (stage 2).

Reading travel diagrams and wiring diagrams

For each of the switching elements used, there is a travel diagram which, dependent of the enabling switch's switch stage, shows the switching states.

The following example is intended to explain these aspects:

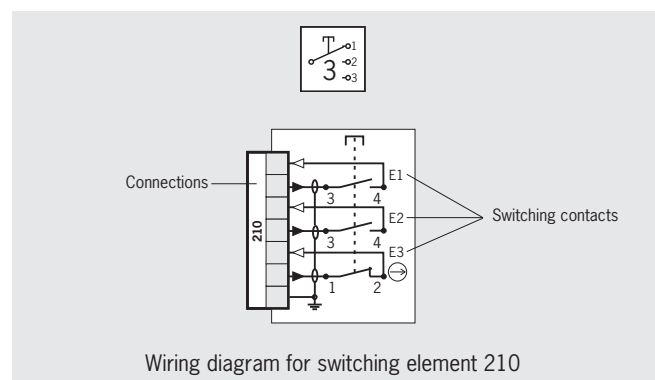

The wiring diagram shows the switching element in the free position (enabling switch not actuated).

The switching element 210 has three switching contacts (E1, E2 and E3). The switching contact E3 is designed as a positively driven contact, the other two switching contacts as normally open contacts.

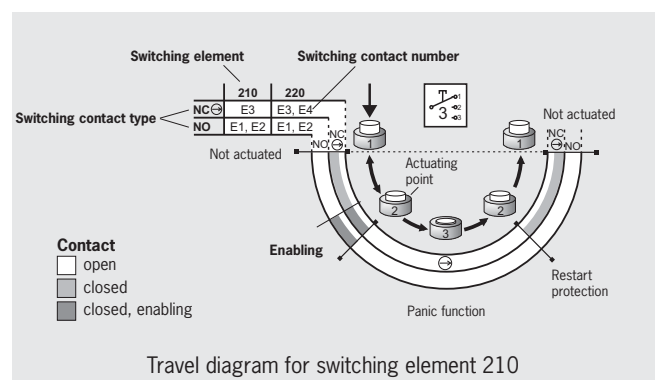

As in this example, in some cases several switching elements are combined in one travel diagram. Here, along with the switching element 210 with the switching contacts E1, E2 and E3, there is also the switching element 220 with the switching contacts E1 to E4.

The letters on the left beside the switching contact E3 define the switching contact type, in this case a positively driven contact (NC).

The following switching contact types are available:

- ▶ NO normally open contact
- ▶ NC normally closed contact
- ▶ NC ⊖ positively driven contact
- ▶ NO/NC three-point switch
(3-stage switching contact with normally open/normally closed function; switching stage dependent on the actuation travel)
- ▶ NO/NC ⊖ three-point switch
(like NO/NC but with positively driven contact)

The travel diagram shows the switching state of each switching contact for the three switch stages "Not actuated", "Enabling" and "Panic function" (pressed past actuating point). Gray areas mean "switch closed", white areas mean "switch open".

In the example for switching element 210 the sequence is as follows:

- ▶ In the not actuated state, the positively driven contact E3 is closed (gray area) and the two normally open contacts E1 and E2 are open.
- ▶ When the switch has reached stage 2, the normally open contacts E1 and E2 are closed, E3 remains closed. This is the enabling area.
- ▶ If the switch is released, the switching contacts return to their initial state.
- ▶ If the switch is pressed beyond the enabling area, all switching contacts are opened. This is the "panic function" area on the travel diagram.
- ▶ If the switch is now released again, the positively driven contact E3 is closed again, the switch system prevents the normally open contacts E1 and E2 closing again at the same time (restart protection).

An optimal sequence is provided by the series connection of E1 (normally open contact) and E3 (positively driven contact), as then enabling is only possible at the actuating point. On pressing through to stage 3, the safe positively driven contact opens the safety circuit. On this switching element E2 can be used as an auxiliary contact or 2nd channel.

Single-channel and dual-channel enabling switches

Often two positively driven contacts and normally open contacts are employed to increase safety using the principle of duplicated design (redundancy). This dual-channel design ensures that on the failure of one channel or on a fault in the control circuit (e.g. in the machine wiring), the safety function can still be provided with the aid of the second channel. An example is given in the wiring diagram for switching element 220:

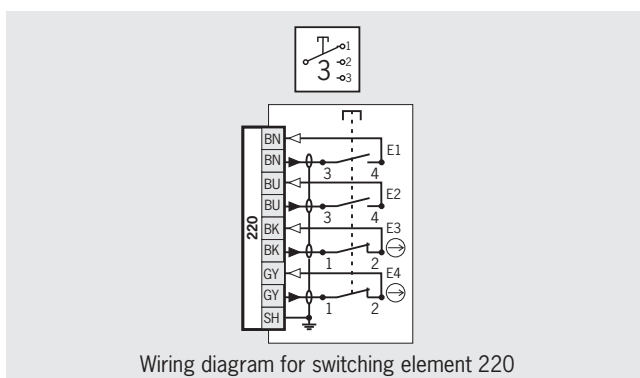

The normally open contact E1 and the positively driven contact E3 as well as the normally open contact E2 and the positively driven contact E4 can be connected externally in series. In this way a dual-channel design is achieved.

Safety in case of faults

Along with the possibility of using positively driven contacts and the possible dual-channel layout of the design, the patented connection cables from EUCHNER provide additional protection on the occurrence of faults. Not only the outer screening of the cable, but also the individual screening of the cores enables, e.g. short circuits or cable breaks due to crushing, to be detected by a control system.

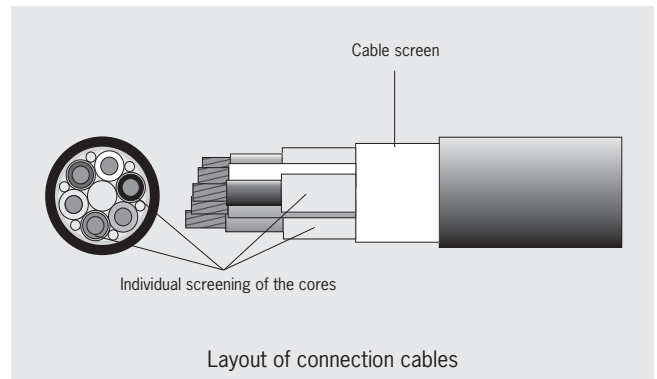

Protection against tampering

An enabling switch can only ensure that operation is free of hazards if it is not bypassed. To prevent tampering, our enabling switches are designed such that it is more difficult to bypass the safety function. The best tampering protection is, however, acceptance with the user.

Ergonomics

To achieve the related user acceptance of a manually operated control, the focus of EUCHNER enabling switches is on safe and balanced handling, even over extended periods (e.g. when observing manufacturing processes). Enabling switches manufactured by EUCHNER have a low weight, an ergonomic housing design and a light, stable actuating point. Both thumb-actuated switches and switches that can be actuated with several fingers in order to maintain the actuating force over an extended period are used.

By selecting a coiled cable with long cable ends, the weight of the switch is reduced as the heavy, spiral part of the cable lies on the floor and only the lighter, straight part needs to be held by the user.



Enabling switches for building in

The enabling devices in series ZSG and the enabling switches in series ZSE and ZXE can be integrated into any housings or control panels. As a result every customer can prepare a customized solution to suit his/her specific application.



Kits for enabling switches

Using enabling switch kits from EUCHNER you can assemble your own customized enabling switch ideally matched to your requirements. The kit is available for the housing G1 as a two or three-stage version and for the ZSM as a three-stage version. Various switching elements are available.

Hand-held enabling switches

The enabling switches in the series ZSM, ZSA, ZSB and ZSR are installed in a housing and are already pre-wired. Depending on version, the hand-held enabling switches feature protection class IP 67 or IP 65. In addition to the enabling function, EUCHNER enabling switches can be equipped with further command buttons (pushbutton, selector switch, key-operated rotary switch or emergency stop device) and LED displays. In this way work processes, such as axis selection and the movement of axes, can be performed directly at the machine using the enabling switch.



Electrical connection

Different cable lengths and cable types are available for the connection of the pre-assembled hand-held enabling switches.

Modern wiring concepts increasingly utilize plug-in connections. The enabling switch does not need to remain permanently connected, but is plugged in as required.

Furthermore, a switch with plug connectors can be easily replaced during servicing work. This configuration results in short downtimes.

The enabling switches ZSM, ZSA, ZSB and ZSR are available with various plug connectors. In addition to the related mating connectors, further accessories are available.

Marking of switching elements

The switching elements used in our enabling switches have a numbering system. A selection of switching elements is available depending on the series.

Explanation of symbols and notation

Symbols and specific notation related to the switches or the switching contact are used time and again in the catalog. The following example is intended to explain these aspects:

Notation

1 NC ⊖ + 1 NO

Explanation

Normally closed contacts are represented by NC, normally open contacts by NO. The number defines how many contacts are available. The symbol after the NC defines that the NC contact is a positively driven contact. This switch therefore has one normally closed contact and one normally open contact; the normally closed contact is a positively driven contact.

Acknowledgment of enabling

Vibration signal

The ZSM enabling switch is optionally equipped with a vibration motor. This permits acknowledgment of enabling, e.g. in a loud environment. The signal pulsates, similar to the vibration signal of cellular telephones.



LED

An LED can also be optionally used as visual acknowledgment. Several products are equipped accordingly.

Emergency stop/machine stop

All emergency-stop devices with red pushbutton must be active in the danger area. Since a plugged connection could be unplugged in certain circumstances, enabling switches with plug connectors are equipped only with a black/yellow machine stop. Otherwise, it must be ensured that confusion between effective and ineffective devices is ruled out.

Selection table for built-in enabling switches ZSE and ZXE

Design			
E	Built-in version (without cable)		
	Function		
	3	3-stage (OFF - enabling - OFF)	
		Connection	
		C	Tab connector, screw terminal, flying lead
			
Enabling switch ZXE	Enabling switch ZSE		
↓	↓	↓	
Design	Stages	Connection	Page
E	3	C	10 - 12
●	●	●	



Built-in enabling switches ZSE and ZXE

- ▶ 3-stage function
- ▶ Dual-channel version
- ▶ Optionally with 22.5 mm or 30.5 mm installation dimension
- ▶ Suitable, e.g., for installation in the hand-held pendant stations HBL or housing G2 or G3



3-stage function

Enabling function is only active in the second stage (middle position, actuating point). If the button is released or pushed further (panic function), the enabling is removed (dependent on the wiring, see function sequence).

Hand-held pendant station HBL

See catalog for hand-held pendant stations.

Switching elements (see also page 8)

- ▶ **111** 1 NO + 1 NC ⊕ + 1 NC
- ▶ **121** 1 NO + 2 NC ⊕ + 1 NC
- ▶ **210** 2 NO + 1 NC ⊕
- ▶ **220** 2 NO + 2 NC ⊕
- ▶ **2202** 2 NO/NC ¹⁾

ZSE, 3-stage function

Tab connector

Dimension drawings

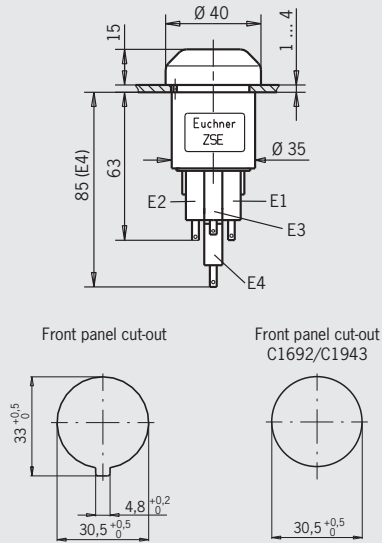

Wiring diagrams/function sequence

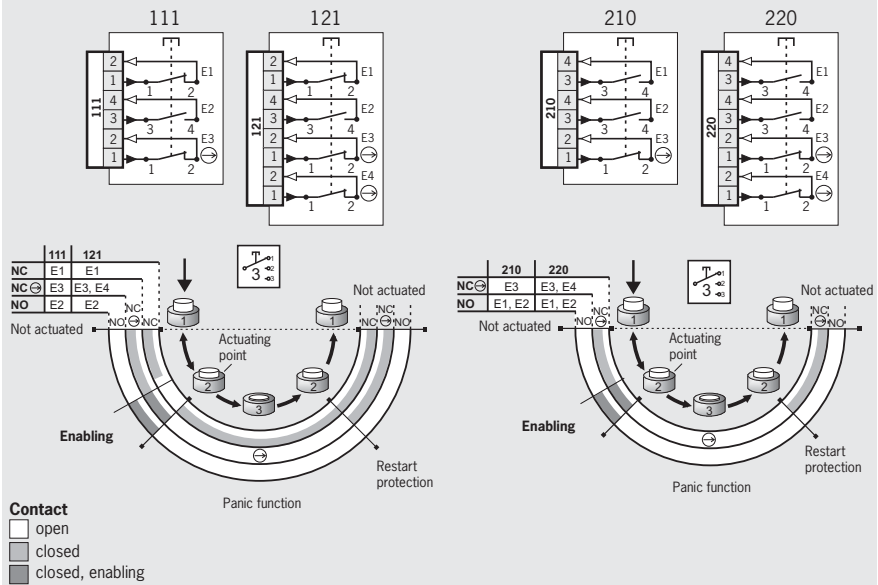

Ordering table

Design	Connection	Version	Switching element				
			111: 1 NO+1 NC ⊕ +1 NC	121: 1 NO+2 NC ⊕ +1 NC	210: 2 NO+1 NC ⊕	220: 2 NO+2 NC ⊕	2202: 2 NO/NC ¹⁾
Built-in 3-stage ZSE	Tab connector		052448 ZSE2-1	070782 ZSE2-3	052449 ZSE2-2	070762 ZSE2-4	On request
		Suitable, e.g., for hand-held pendant stations HBL	On request	On request	070752 ²⁾ ZSE2-2C1692	083477 ²⁾ ZSE2-4C1943	On request

1) From position 1 to position 2 → NO contact; from position 2 to position 3 → NC contact.

2) No BG type examination

ZSE, 3-stage function Tab connection, with spacer

Dimension drawings

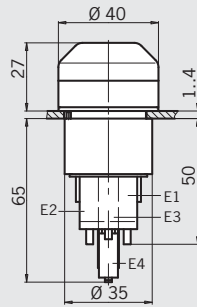

Front panel cut-out

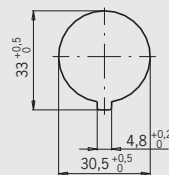

Wiring diagrams/function sequence

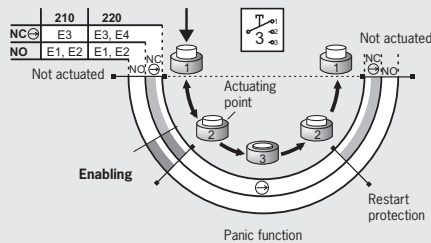
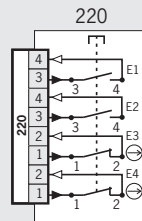

- Contact**
- open
 - closed
 - closed, enabling

Ordering table

Design	Connection	Version	Switching element				
			111: 1 NO+1 NC \ominus +1 NC	121: 1 NO+2 NC \ominus +1 NC	210: 2 NO+1 NC \ominus	220: 2 NO+2 NC \ominus	2202: 2 NO/NC ¹⁾
Built-in 3-stage ZSE	Tab connector	With spacer for installation in housing G2 or G3	On request	On request	On request	091098 ZSE2-4C1801	On request

1) From position 1 to position 2 \Rightarrow NO contact; from position 2 to position 3 \Rightarrow NC contact.



ZXE, 3-stage function Screw terminals

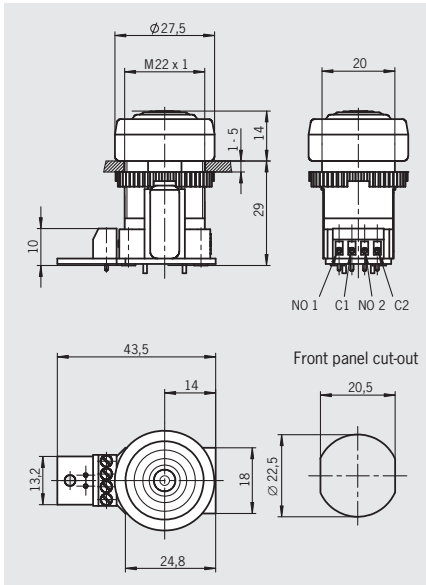

ZXE, 3-stage function Screw terminals, with click sound ¹⁾

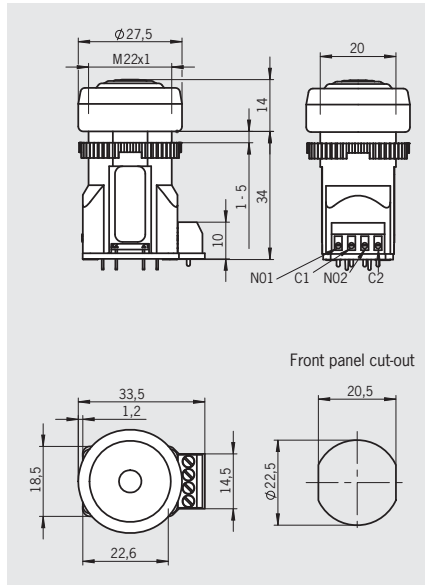

ZXE, 3-stage function Tab connectors, with click sound ¹⁾

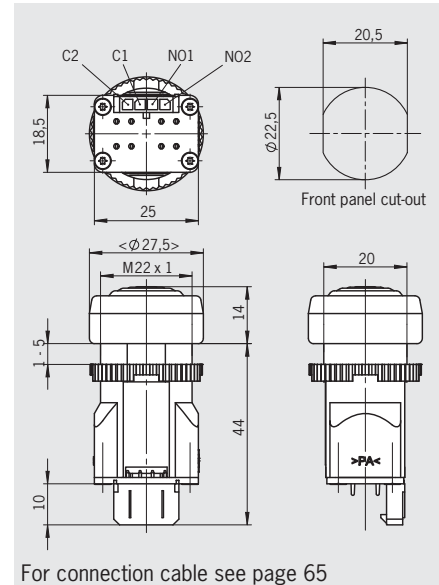

Wiring diagrams/function sequence

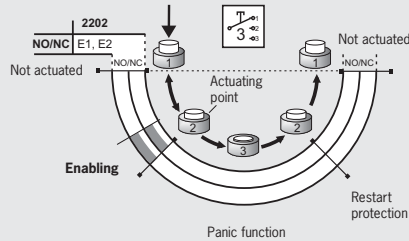
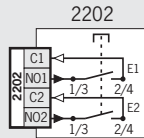

- Contact**
- open
 - closed
 - closed, enabling

Ordering table

Design	Connection	Version	Switching element
			2202: 2 NO/NC ²⁾
Built-in 3-stage ZXE	Screw terminals	Slow-action switching contact	091336 ZXE-091336
		Snap-action switching contact	104833 ZXE-104833
	Tab connectors	Snap-action switching contact	111276 ZXE-111276

1) With version ZXE-104833 a click sounds during the change from stage 1 to stage 2 and during the return from stage 2 to stage 1.
 2) From position 1 to position 2 ⇒ NO contact; from position 2 to position 3 ⇒ NC contact.

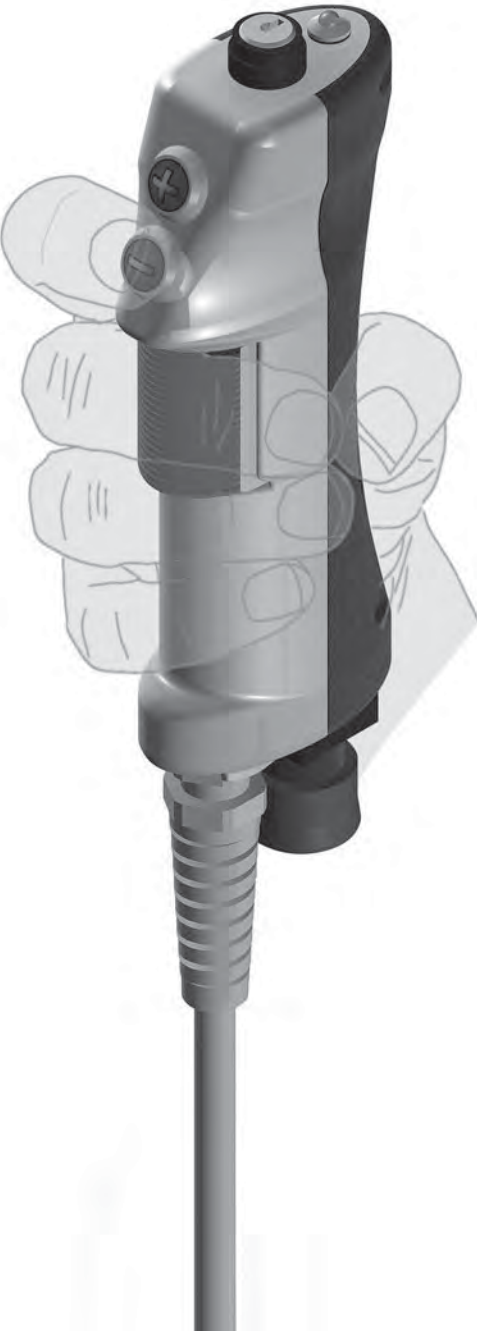

Article overview for enabling switch ZSM

Page	16	16	17	18	18	19	19	20	21	22	22	22	23	23	24	24	25	
Plug connector	-	-	-	-	-	RC17	HAN Q17	-	-	-	-	-	RC12	RC12	RC12	RC12	-	
Cable length [m]	Coiled connection cable	-	-	1.88-5	-	-	1.88-5	1.4-3.8	-	1.88-5	-	-	3-9	1.88-5	1.88-5	-	-	
	Straight connection cable	5	5	-	5	5	-	5	-	5	5	-	-	-	5	13	10	
Vibration signal	●	●	-	●	●	-	●	-	-	●	●	●	●	●	-	-	●	
ZS	3 W	3 W	3 W	2 NO	2 NO	2 NO	2 NO	3 W	1 C + 1 NO	2 NO	2 NO	2 NO	2 NO	2 NO	2 NO	2 NO	2 NO	
Bottom Stop command device	Emergency stop red 2 NC ⊖	-	-	-	-	●	-	-	-	-	-	-	-	-	-	-	-	
	Machine stop black 2 NC ⊖	-	-	-	●	-	●	-	-	-	-	-	-	-	-	-	-	
Key-operated rotary switch	-	-	-	-	-	-	-	-	-	-	-	-	-	-	-	-	-	
Front	One-touch function (joystick)	-	-	-	-	-	-	-	-	-	-	-	-	-	-	-	-	
	Bottom pushbutton	white	white	white	⊖	⊖	⊖	⊖	-	⊖	⊖	⊖	⊖	⊖	⊖	⊖	⊖	
	Top pushbutton	-	-	-	⊕	⊕	⊕	⊖	-	⊕	⊕	⊕	⊕	⊕	⊕	⊕	⊕	
Top Stop command device	Emergency stop red 2 NC ⊖	-	●	●	-	-	-	-	-	-	-	-	-	-	-	-	-	
	Machine stop black 2 NC ⊖	●	-	-	-	-	-	-	-	-	-	-	-	-	-	-	-	
Top	LED indicator	●	●	-	●	●	●	-	2 x ●	●	●	●	●	●	-	-	-	
	Pushbutton	-	-	-	-	-	● Reset	-	-	-	-	-	-	-	-	-	-	
	Key-operated rotary switch	-	-	-	●	●	-	-	-	-	-	-	-	-	-	-	-	
	Selector switch	-	-	-	-	-	3-stage 1 of 3	-	-	-	-	-	-	-	-	-	-	4-stage 1 of 4
	Potentiometer	-	-	-	-	-	-	-	-	-	-	-	-	-	-	-	-	
	Order No./item	102059 ZSM4201-102059	102966 ZSM4204-102966	105645 ZSM4204-105645	099715 ZSM2101-099715	103126 ZSM2101-103126	110317 ZSM2301-110317	105075 ZSM2301-105075	099713 ZSM4200-099713	111871 ZSM2300-111871	099714 ZSM2100-099714	109971 ZSM2300-109971	112803 ZSM2300-112803	111462 ZSM2300-111462	111594 ZSM2100-111594	099716 ZSM2300-099716	113290 ZSM2300-113290	100697 ZSM2200-100697

106103 ZSM2100-106103	-	5-stage Gray code	-	-	⊕	⊖	-	-	-	-	2 NO	-	3	-	-	25
105308 ZSM2200-105308	-	12-stage Gray code	-	-	⊕	⊖	-	-	-	-	3 NO	-	5	-	-	26
103462 ZSM3100-103462	-	12-stage Gray code	-	-	⊕	⊖	-	-	-	-	2 NO + 1 C	1.88 - 5	-	-	-	26
112033 ZSM2200-112033	-	4-stage+ 12-stage Gray code	-	-	⊕	⊖	-	-	-	-	2 NO	-	1.5	-	RC17	27
105362 ZSM2200-105362	-	-	●	-	-	-	-	-	-	-	2 NO	-	8	-	-	28
111914 ZSM2200-111914	●	-	-	-	-	Black	-	●	-	-	2 NO	-	10	-	-	28
110338 ZSM2300-110338	-	-	●	-	⊕	⊖	-	-	-	-	2 NO	1.55 - 3.5	-	-	RC12	29
106670 ZSM2300-106670	-	-	●	Reset	⊖	⊕	-	-	-	-	2 NO	1.25 - 3.1	-	-	HAN Q17	30
106374 ZSM2300-106374	-	-	-	Black	-	-	-	●	-	-	1 NO + 1 C	-	-	-	RC17	30

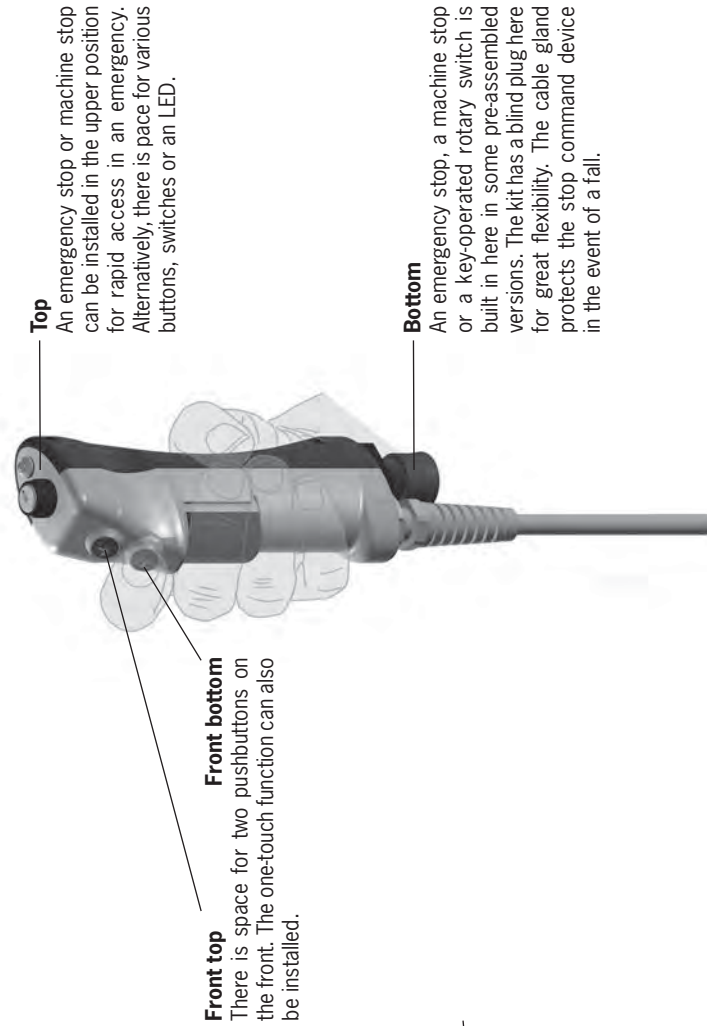

Enabling switch ZSM with upper stop command device



- ▶ 3-stage function
- ▶ Stop command device
- ▶ Vibration signal optional
- ▶ LED indicator optional
- ▶ Pushbutton
- ▶ Coiled connection cable optional

ZSM4201-102059, 3-stage function
Flying lead, machine stop

ZSM4204-102966, 3-stage function
Flying lead, emergency stop device

3-stage function

Enabling function is only active in the second stage (middle position, actuating point). If the button is released or pushed further (panic function), the enabling is removed (dependent on the wiring, see function sequence).

Stop command device

Two-channel emergency stop device (red, with pull-to-reset button) or machine stop (black, with pull-to-reset button) on the switch housing, for different wiring concepts.

Upper position for rapid access in an emergency

Vibration signal

The vibration signal is used for tactile feedback of the enabling position.

LED indicator

The LED indicator is used for visual feedback directly at the enabling switch.

Pushbutton

Additional functions can be run directly at the enabling switch using the buttons.

Cable

The high-quality connection cables are available in a straight or coiled version.

Dimension drawing

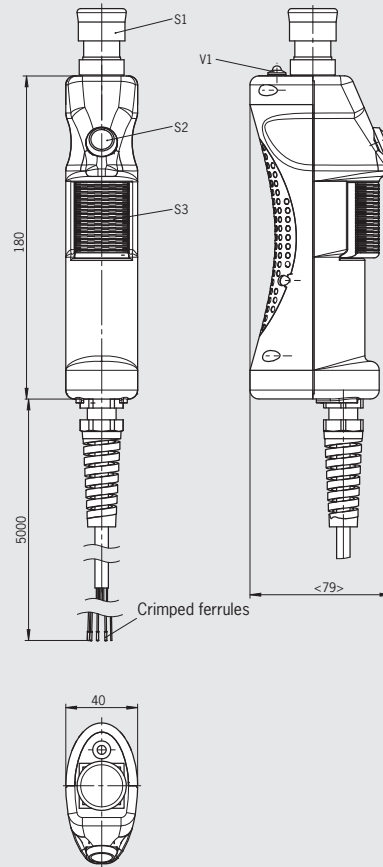

For wiring diagram see page 70

Switching element/function sequence

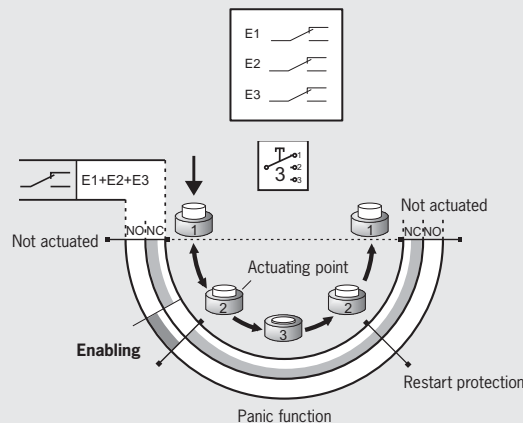

Ordering table

Design	Connection	Cable length	Version	Order No./item
ZSM	Flying lead 23 x 0.14 mm ²	5 m Straight	Enabling switch with 3 changeover contacts (S3), black machine stop (S1), vibration signal, yellow LED indicator (V1), white pushbutton (S2)	102059 ZSM4201-102059
			Enabling switch with 3 changeover contacts (S3), red emergency stop device (S1), vibration signal, yellow LED indicator (V1), white pushbutton (S2)	102966 ZSM4204-102966



ZSM4204-105645, 3-stage function
Flying lead, emergency stop device

Dimension drawing

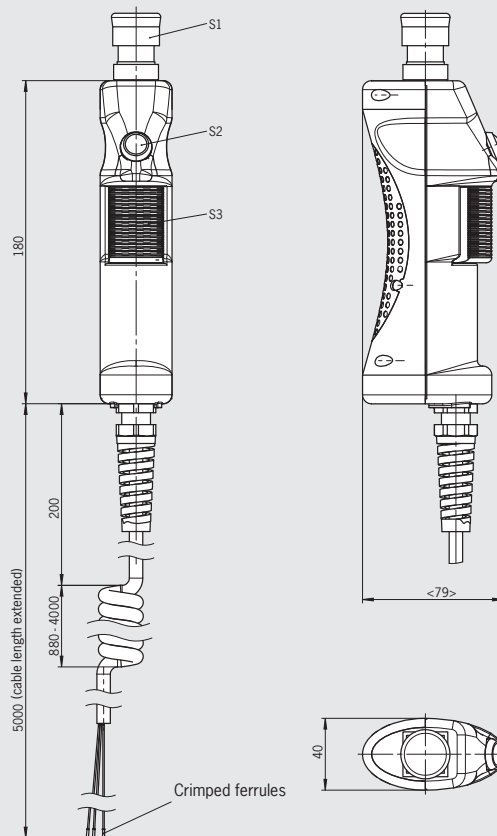

For wiring diagram see page 70

Switching element/function sequence

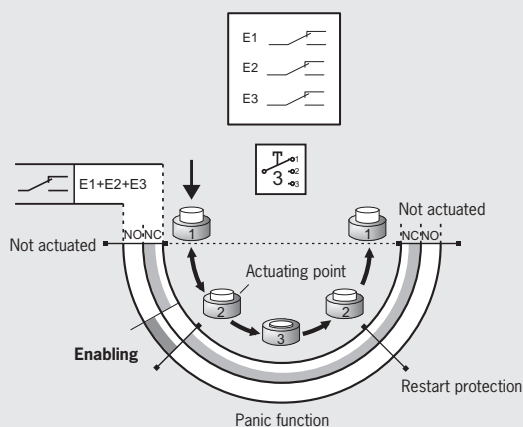

Ordering table

Design	Connection	Cable length	Version	Order No./item
ZSM	Flying lead 23 x 0.14 mm ²	1.88 ... 5 m coiled	Enabling switch with 3 changeover contacts (S3), red emergency stop device (S1) white pushbutton (S2)	105645 ZSM4204-105645

For technical data see page 71

Enabling switch ZSM with lower stop command device



- ▶ 3-stage function
- ▶ Stop command device
- ▶ Vibration signal optional
- ▶ LED indicator
- ▶ Reset button optional
- ▶ + and – buttons
- ▶ Selector switch optional
- ▶ Key-operated rotary switch optional
- ▶ Coiled connection cable optional
- ▶ Plug connector optional

ZSM2101-099715, 3-stage function
Flying lead, machine stop

ZSM2101-103126, 3-stage function
Flying lead, emergency stop device

3-stage function

Enabling function is only active in the second stage (middle position, actuating point). If the button is released or pushed further (panic function), the enabling is removed (dependent on the wiring, see function sequence).

Stop command device

Two-channel emergency stop device (red, with pull-to-reset button) or machine stop (black, with pull-to-reset button) on the switch housing, for different wiring concepts.

Lower position, protected by anti-kink cable gland in case of a fall.

Vibration signal

The vibration signal is used for tactile feedback of the enabling position.

LED indicator

The LED indicator is used for visual feedback directly at the enabling switch.

Reset button

Button for reset function directly from the enabling switch. Laser inscription on the button head: **C** (cancel).

+ and – buttons

These buttons can be configured individually. For example for moving axes in the positive or negative direction.

Selector switch

As required, the adjustable detent positions can, e.g., be used for axis, speed or range selection.

Key-operated rotary switch

For individual use, e.g. as operating mode selector switch.

Cable

The high-quality connection cables are available in a straight or coiled version.

Dimension drawing

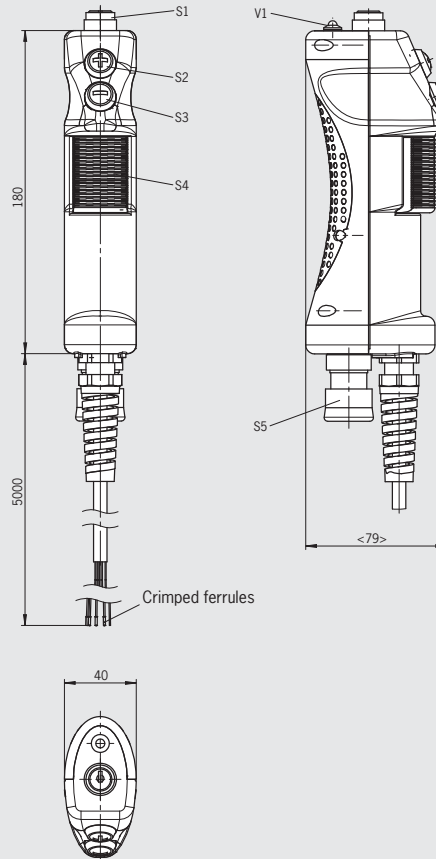

For wiring diagram see page 71

Switching element/function sequence

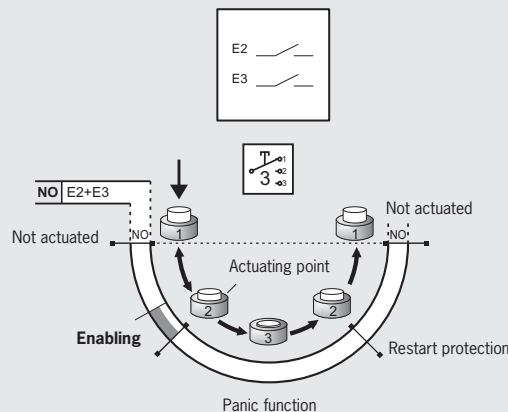

Ordering table

Design	Connection	Cable length	Version	Order No./item
ZSM	Flying lead 23 x 0.14 mm ²	5 m Straight	Enabling switch with 2 NO contacts (S4), black machine stop (S5), vibration signal, yellow LED indicator (V1), +/- buttons (S2/S3), key-operated rotary switch (S1)	099715 ZSM2101-099715
			Enabling switch with 2 NO contacts (S4), red emergency stop device (S5), vibration signal, yellow LED indicator (V1), +/- buttons (S2/S3), key-operated rotary switch (S1)	103126 ZSM2101-103126



ZSM2301-110317, 3-stage function Plug connector RC17, machine stop

ZSM2301-105075, 3-stage function Plug connector HAN Q17, machine stop

Dimension drawing

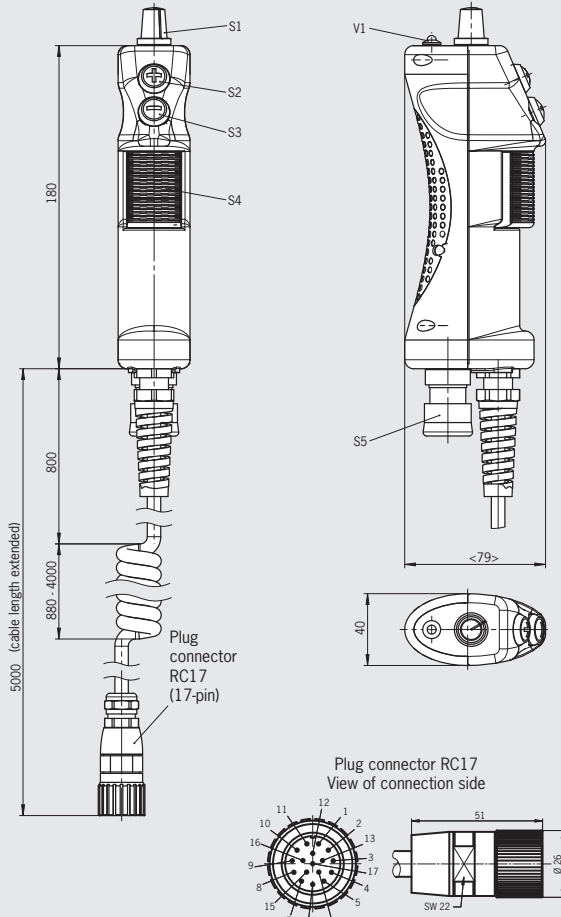

For wiring diagram see page 71
For mating connectors see page 65

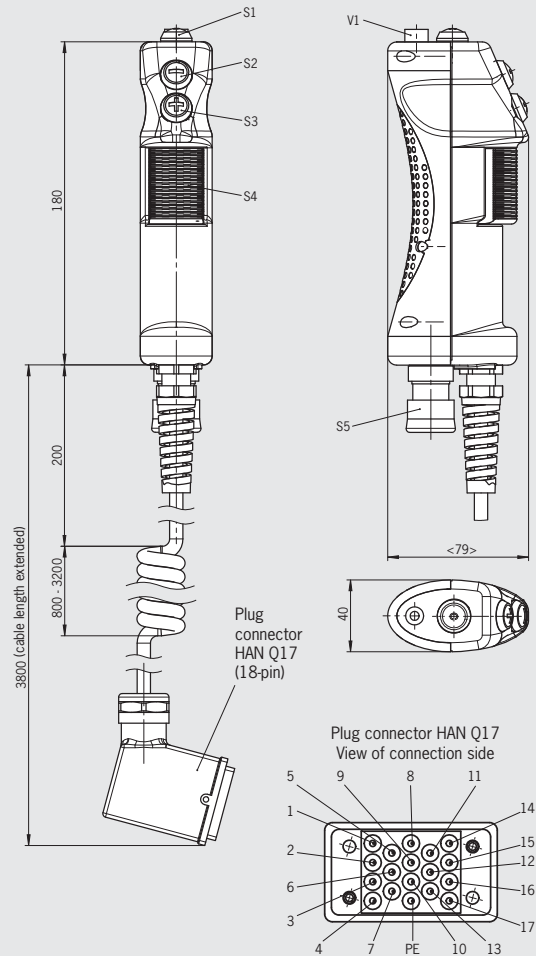

For wiring diagram see page 71

Switching element/function sequence

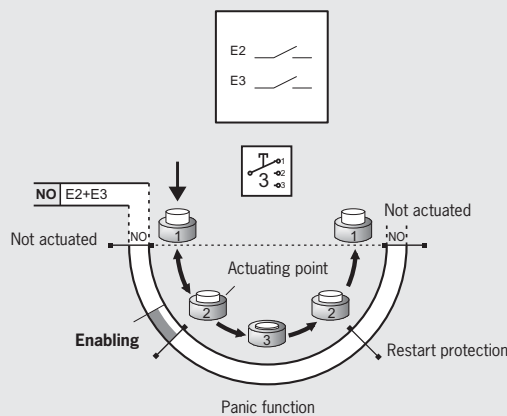

Ordering table

Design	Connection	Cable length	Version	Order No./item
ZSM	RC17 Plug connector (17-pin)	1.88 ... 5 m coiled	Enabling switch with 2 NO contacts (S4), black machine stop (S5), yellow LED indicator (V1), +/- buttons (S2/S3), selector switch, 3-stage 1 from 3 (S1)	110317 ZSM2301-110317
	HAN Q17 Plug connector (18-pin)	1.4 ... 3.8 m coiled	Enabling switch with 2 NO contacts (S4), black machine stop (S5), vibration signal, red/green LED indicator (V1), buttons +/- (S3/S2), reset button (S1)	105075 ZSM2301-105075

For technical data see page 71



Enabling switch ZSM without stop command device

- ▶ 3-stage function
- ▶ Vibration signal optional
- ▶ LED indicator optional
- ▶ + and - buttons optional
- ▶ Plug connector optional

3-stage function

Enabling function is only active in the second stage (middle position, actuating point). If the button is released or pushed further (panic function), the enabling is removed (dependent on the wiring, see function sequence).

Vibration signal

The vibration signal is used for tactile feedback of the enabling position.

LED indicator

The LED indicator is used for visual feedback directly at the enabling switch.

+ and - buttons

These buttons can be configured individually. For example for moving axes in the positive or negative direction.

Cable

The high-quality connection cables are available in a straight or coiled version.

ZSM4200-099713, 3-stage function

Flying lead

Dimension drawing

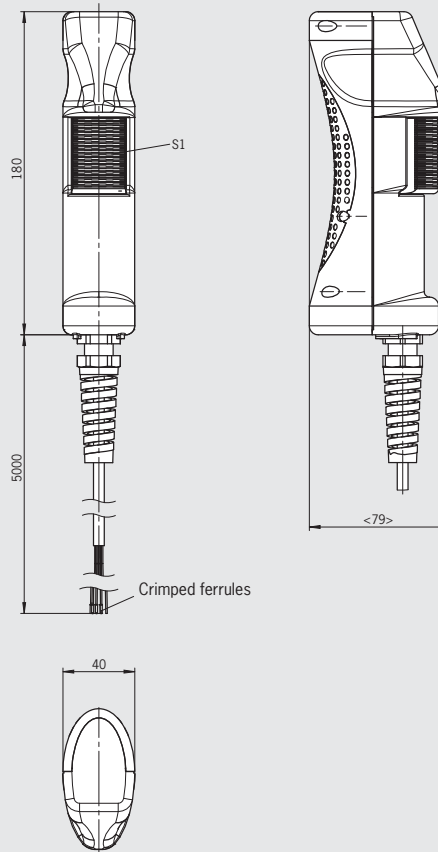

For wiring diagram see page 72

Switching element/function sequence

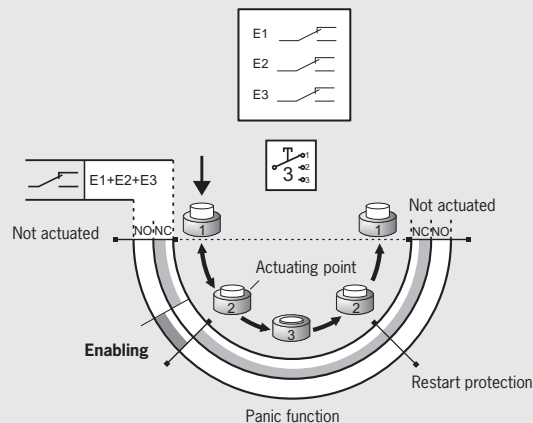

Ordering table

Design	Connection	Cable length	Version	Order No./item
ZSM	Flying lead 12 x 0.14 mm ²	5 m Straight	Enabling switch with 3 changeover contacts (S1)	099713 ZSM4200-099713



ZSM2300-111871, 3-stage function
Flying lead

Dimension drawing

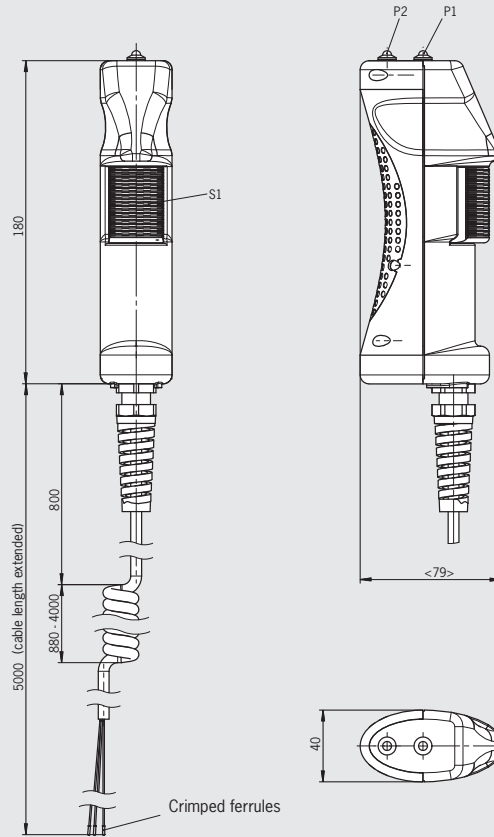

For wiring diagram see page 72

Switching element/function sequence

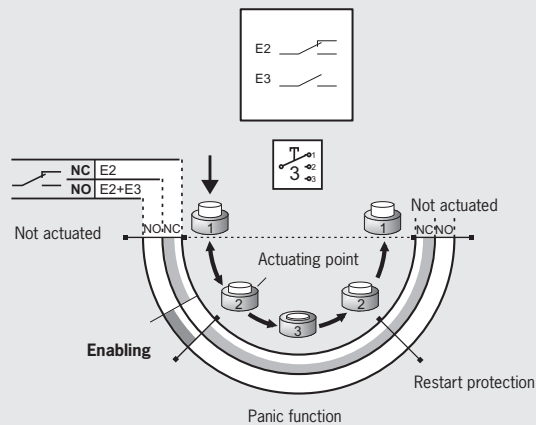

Ordering table

Design	Connection	Cable length	Version	Order No./item
ZSM	Flying lead 12 x 0.14 mm ²	1.88 ... 5 m coiled	Enabling switch with 1 changeover contact and one NO contact (S1), 2 green (P1) and yellow (P2) LED indicators	111871 ZSM2300-111871

Please turn over

For technical data see page 71



ZSM2100-112803, 3-stage function Flying lead

ZSM2100-099714, 3-stage function Flying lead

ZSM2300-109971, 3-stage function Flying lead

Dimension drawing

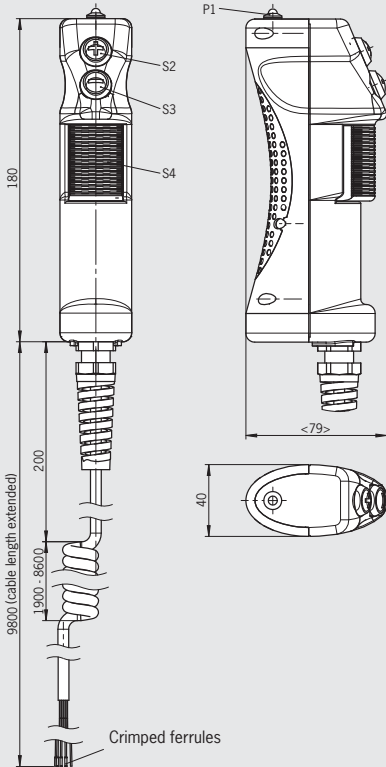

For wiring diagram see page 72

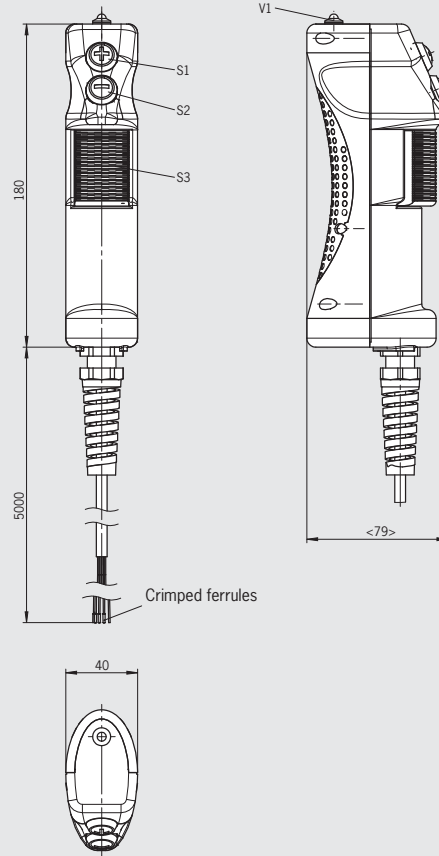

For wiring diagram see page 72

Switching element/function sequence

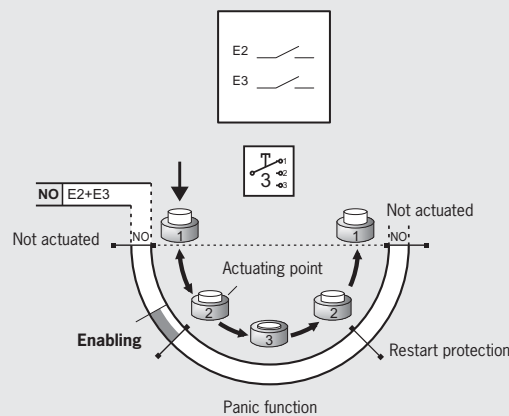

Ordering table

Design	Connection	Cable length	Version	Order No./item
ZSM	Flying lead 12 x 0.14 mm ²	3 ... 9 m coiled	Enabling switch with 2 NO contacts (S3), vibration signal, yellow LED indicator (V1), buttons +/- (S1/S2), alternative wiring	112803 ZSM2300-112803
		5 m Straight	Enabling switch with 2 NO contacts (S3), vibration signal, yellow LED indicators (V1), buttons +/- (S1/S2)	099714 ZSM2100-099714
			Enabling switch with 2 NO contacts (S3), vibration signal, yellow LED indicator (V1), buttons +/- (S1/S2), alternative wiring	109971 ZSM2300-109971



ZSM2300-111462, 3-stage function
Plug connector RC12

ZSM2100-111594, 3-stage function
Plug connector RC12

Dimension drawing

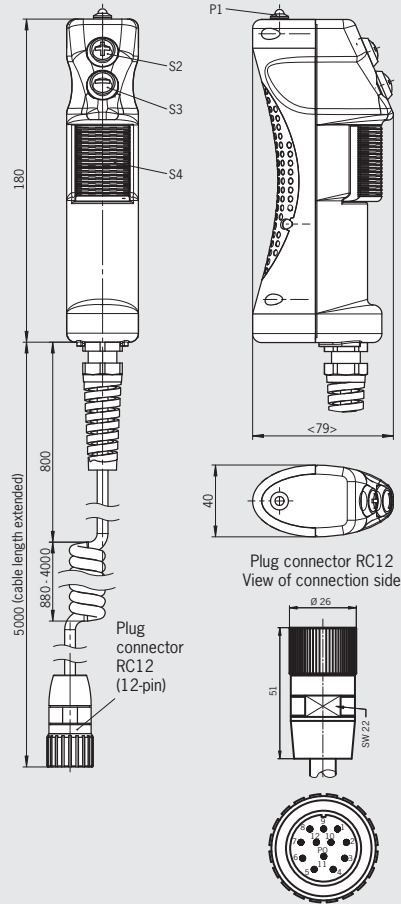

For wiring diagram see page 73
For mating connectors see page 65

Please turn over

Switching element/function sequence

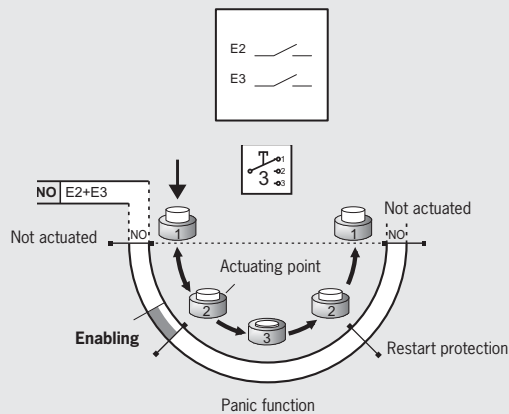

Ordering table

Design	Connection	Cable length	Version	Order No./item
ZSM	RC12 Plug connector (12-pin)	1.88 ... 5 m coiled	Enabling switch with 2 NO contacts (S3), vibration signal, yellow LED indicator (P1), buttons +/- (S1/S2)	111462 ZSM2300-111462
			Enabling switch with 2 NO contacts (S3), vibration signal, yellow LED indicator (P1), buttons +/- (S1/S2), alternative wiring	111594 ZSM2100-111594

For technical data see page 71



ZSM2300-099716, 3-stage function
Plug connector RC12

ZSM2300-113290, 3-stage function
Plug connector RC12

Dimension drawing

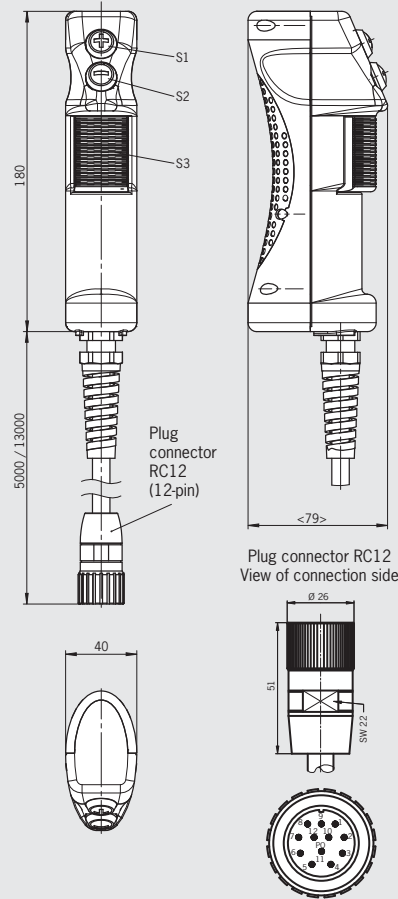

For wiring diagram see page 73
For mating connectors see page 65

Switching element/function sequence

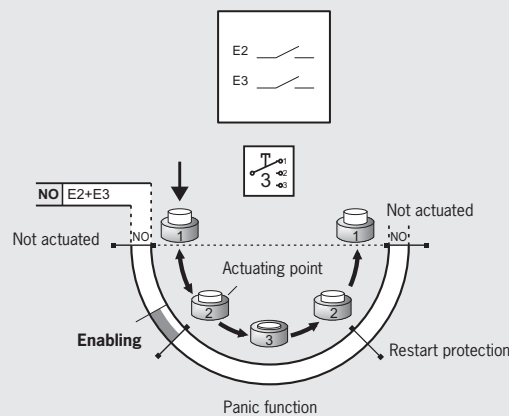

Ordering table

Design	Connection	Cable length	Version	Order No./item
ZSM	RC12 Plug connector (12-pin)	5 m Straight	Enabling switch with 2 NO contacts (S3), buttons +/- (S1/S2)	099716 ZSM2300-099716
		13 m Straight	Enabling switch with 2 NO contacts (S3), buttons +/- (S1/S2)	113290 ZSM2300-113290

Enabling switch ZSM without stop command device



- ▶ 3-stage function
- ▶ Vibration signal optional
- ▶ LED indicator optional
- ▶ + and - buttons
- ▶ Selector switch
- ▶ Coiled connection cable optional

ZSM2200-100697, 3-stage function
Flying lead, selector switch

ZSM2100-106103, 3-stage function
Flying lead, selector switch

3-stage function

Enabling function is only active in the second stage (middle position, actuating point). If the button is released or pushed further (panic function), the enabling is removed (dependent on the wiring, see function sequence).

Vibration signal

The vibration signal is used for tactile feedback of the enabling position.

LED indicator

The LED indicator is used for visual feedback directly at the enabling switch.

+ and - buttons

These buttons can be configured individually. For example for moving axes in the positive or negative direction.

Selector switch

As required, the adjustable detent positions can, e.g., be used for axis, speed or range selection.

Cable

The high-quality connection cables are available in a straight or coiled version.

Dimension drawing

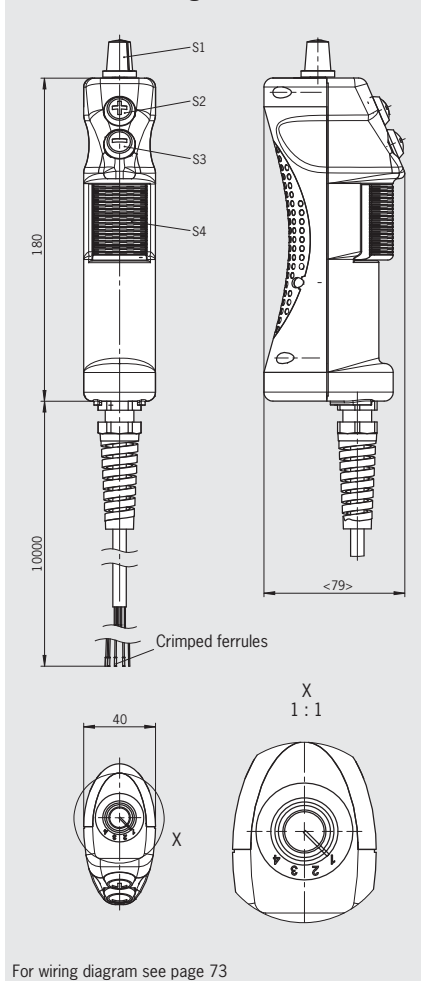

For wiring diagram see page 73

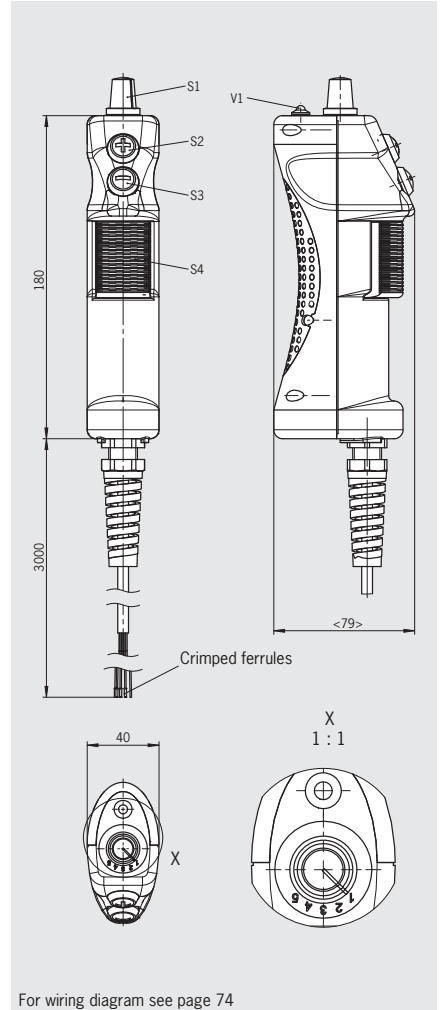

For wiring diagram see page 74

Please turn over

Switching element/function sequence

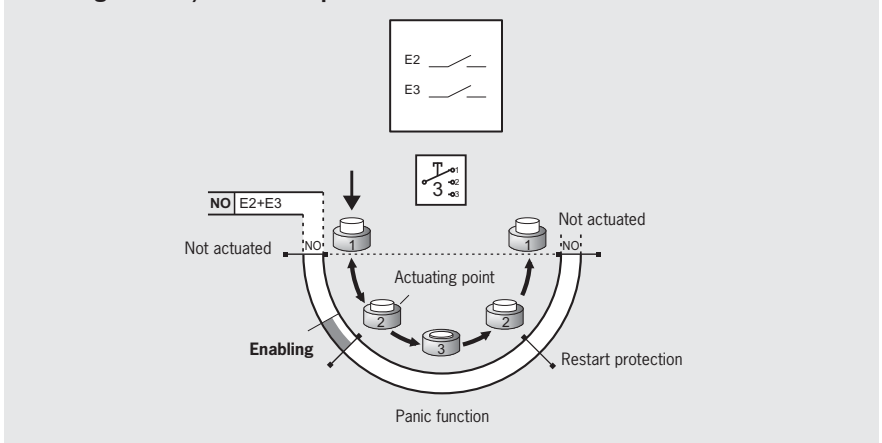

Ordering table

Design	Connection	Cable length	Version	Order No./item
ZSM	Flying lead 23 x 0.14 mm ²	10 m Straight	Enabling switch with 2 NO contacts (S4), vibration signal, buttons +/- (S2/S3), selector switch 4-stage 1 from 4 (S1)	100697 ZSM2200-100697
	Flying lead 12 x 0.14 mm ²	3 m Straight	Enabling switch with 2 NO contacts (S4), yellow LED indicator (V1), buttons +/- (S2/S3), selector switch 5-stage Gray code (S1)	106103 ZSM2100-106103

For technical data see page 71



ZSM2200-105308, 3-stage function

Flying lead, selector switch

Dimension drawing

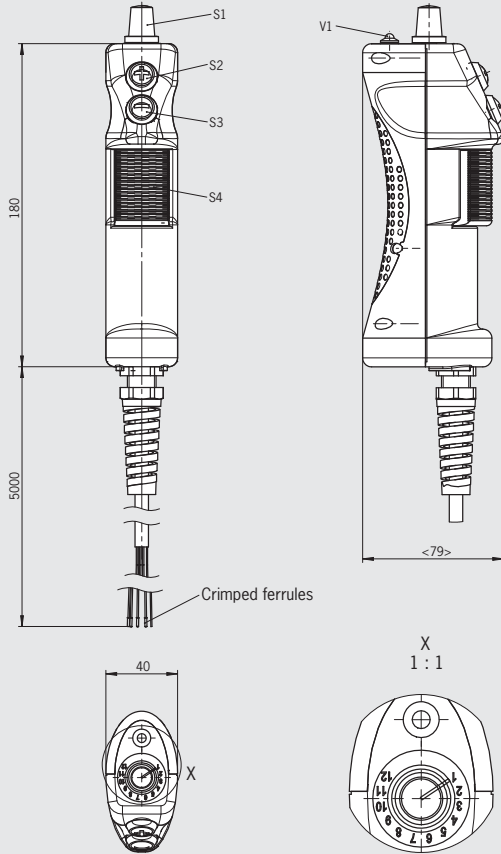

For wiring diagram see page 74

ZSM3100-103462, 3-stage function

Flying lead, selector switch

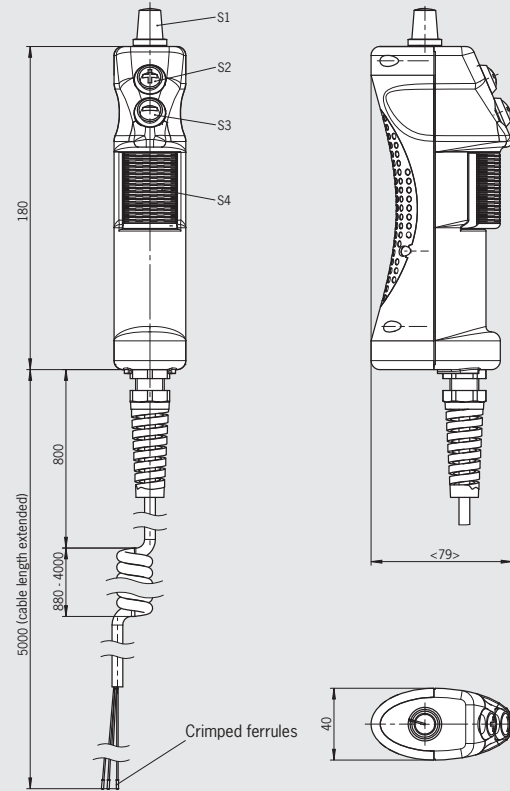

For wiring diagram see page 74

Switching element/function sequence

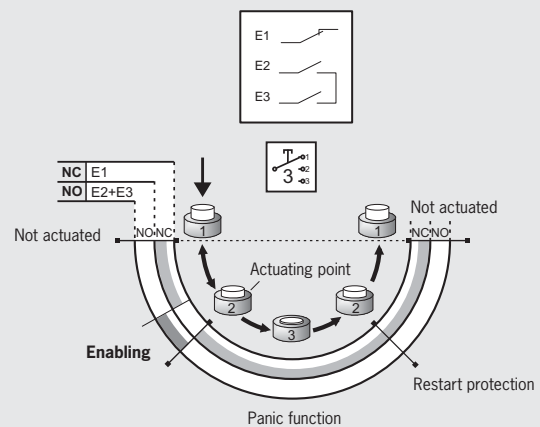
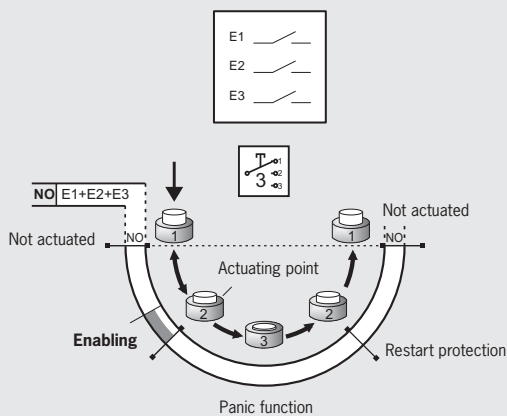

Ordering table

Design	Connection	Cable length	Version	Order No./item
ZSM	Flying lead 23 x 0.14 mm ²	5 m Straight	Enabling switch with 3 NO contacts (S4), yellow LED indicator (V1), buttons +/- (S2/S3), selector switch 12-stage Gray code (S1)	105308 ZSM2200-105308
	Flying lead 12 x 0.14 mm ²	1.88 ... 5 m coiled	Enabling switch with 1 NC contact and 2 NO contacts (S4), buttons +/- (S2/S3), selector switch 12-stage Gray code (S1)	103462 ZSM3100-103462



ZSM2200-112033, 3-stage function
 Plug connector RC17, 2-stage switch

Dimension drawing

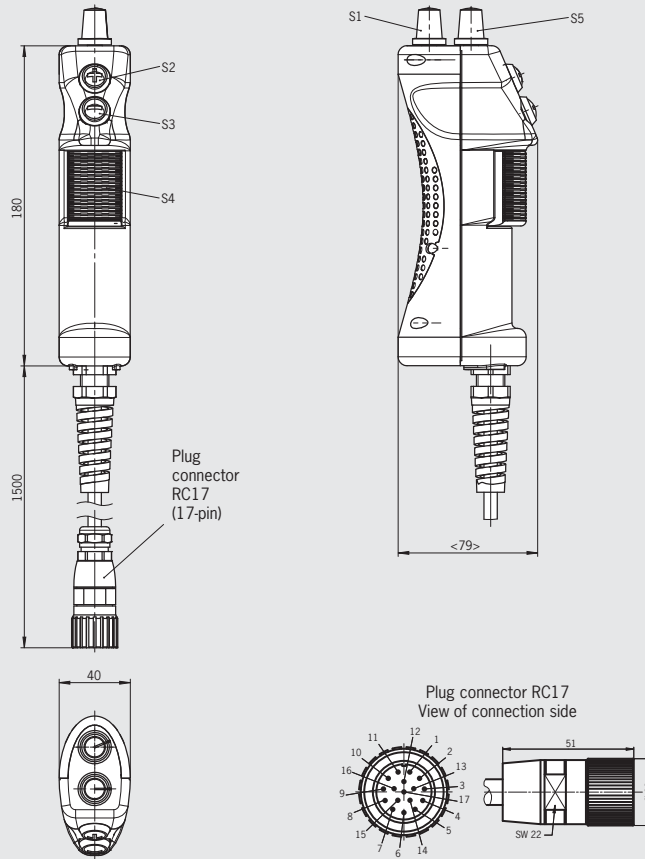

For wiring diagram see page 74
 For mating connectors see page 65

Switching element/function sequence

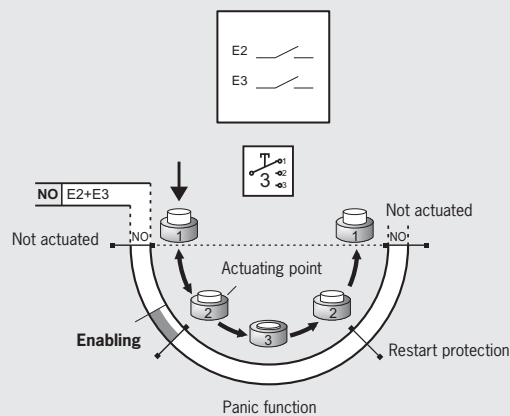

Ordering table

Design	Connection	Cable length	Version	Order No./item
ZSM	RC17 Plug connector (17-pin)	1.5 m Straight	Enabling switch with 2 NO contacts (S4), vibration signal, buttons +/- (S2/S3), selector switch 4-stage Gray code (S1), selector switch 12-stage Gray code (S5)	112033 ZSM2200-112033

For technical data see page 71

Enabling switch ZSM without stop command device



- ▶ 3-stage function
- ▶ Vibration signal optional
- ▶ LED indicator optional
- ▶ Reset button optional
- ▶ + and – buttons optional
- ▶ Pushbutton optional
- ▶ Key-operated rotary switch optional
- ▶ Mini joystick optional
- ▶ Coiled connection cable optional
- ▶ Plug connector optional

3-stage function

Enabling function is only active in the second stage (middle position, actuating point). If the button is released or pushed further (panic function), the enabling is removed (dependent on the wiring, see function sequence).

Vibration signal

The vibration signal is used for tactile feedback of the enabling position.

LED indicator

The LED indicator is used for visual feedback directly at the enabling switch.

Reset button

Button for reset function directly from the enabling switch. Laser inscription on the button head: **C** (cancel).

+ and – buttons

These buttons can be configured individually. For example for moving axes in the positive or negative direction.

Pushbutton

Additional functions can be run directly at the enabling switch using the buttons.

Key-operated rotary switch

For individual use, e.g. as operating mode selector switch.

Rotary potentiometer

For individual use, e.g. for adjusting the speed.

One-touch function (joystick)

The four contacts are connected to a common pin. This permits a one-touch function irrespective of the actuating direction.

Cable

The high-quality connection cables are available in a straight or coiled version.

ZSM2200-105362, 3-stage function

Flying lead, key-operated rotary switch

ZSM2200-111914, 3-stage function

Flying lead, key-operated rotary switch, potentiometer

Dimension drawing

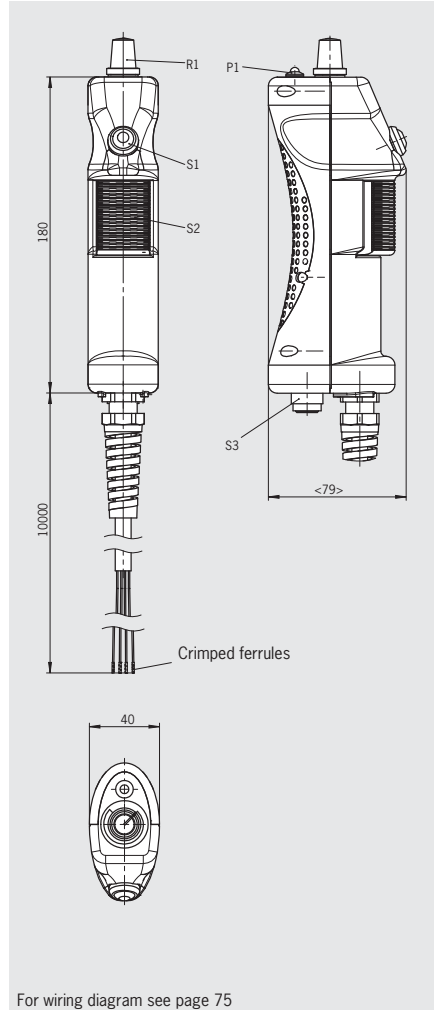
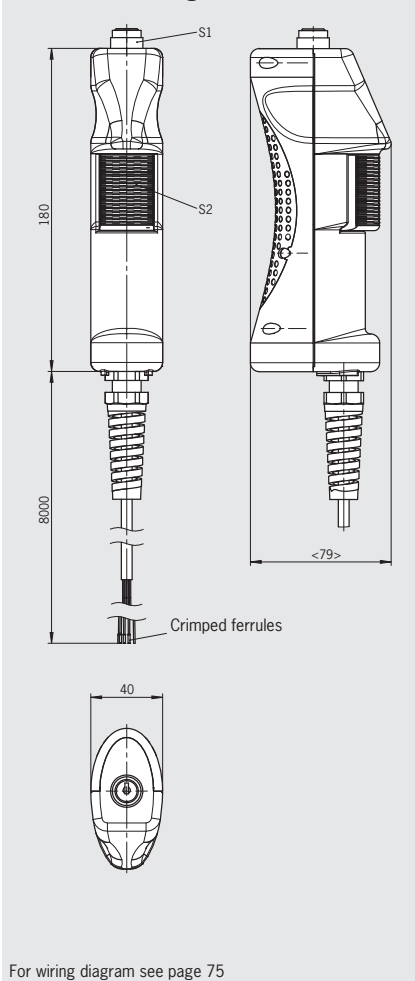

For wiring diagram see page 75

For wiring diagram see page 75

Switching element/function sequence

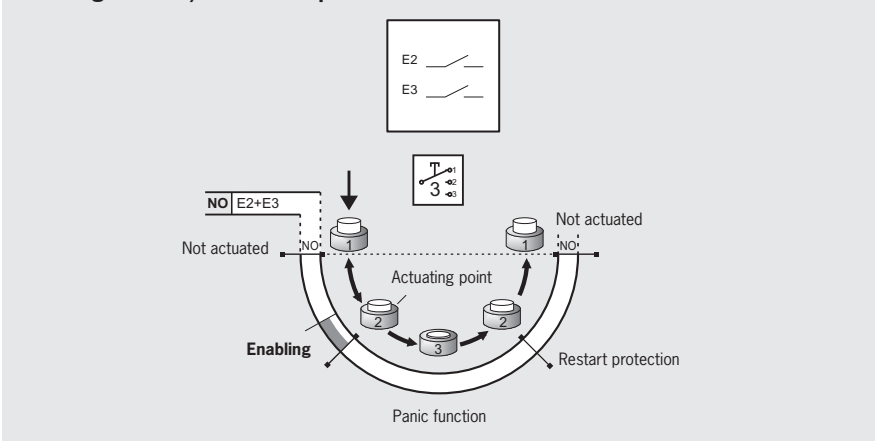

Ordering table

Design	Connection	Cable length	Version	Order No./item
ZSM	Flying lead 12 x 0.14 mm ²	8 m Straight	Enabling switch with 2 NO contacts (S2), vibration signal, key-operated rotary switch (S1)	105362 ZSM2200-105362
	RC12 Plug connector (12-pin)	10 m Straight	Enabling switch with 2 NO contacts (S4), rotary potentiometer 4.7 kΩ (R1), yellow LED indicator (P1), black pushbutton (S1), key-operated rotary switch (S3)	111914 ZSM2200-111914



ZSM2300-110338, 3-stage function
 Plug connector RC12, key operated switch

Dimension drawing

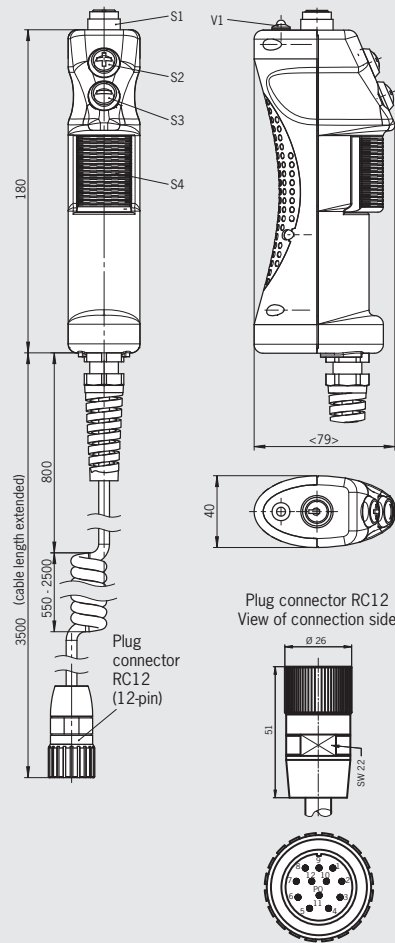

For wiring diagram see page 75
 For mating connectors see page 65

Please turn over

Switching element/function sequence

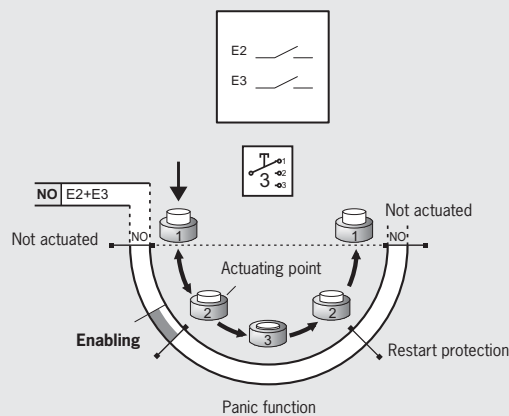

Ordering table

Design	Connection	Cable length	Version	Order No./item
ZSM	RC12 Plug connector (12-pin)	1.55 ... 3.5 m coiled	Enabling switch with 2 NO contacts (S4), yellow LED indicator (V1), buttons +/- (S2/S3), key-operated rotary switch (S1)	110338 ZSM2300-110338

For technical data see page 71



ZSM2300-106670, 3-stage function Plug connector HAN Q17, reset button

Dimension drawing

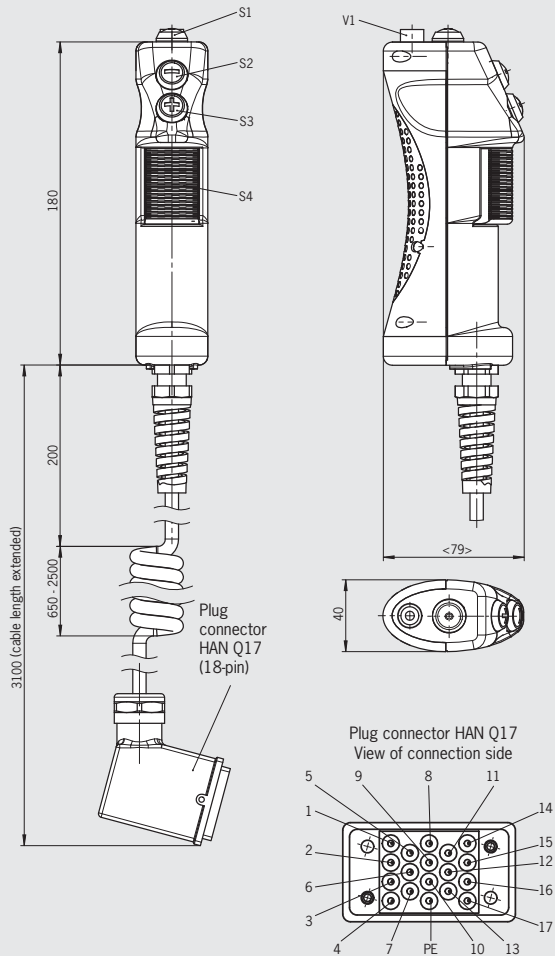

For wiring diagram see page 75

ZSM2300-106374, 3-stage function Plug connector RC17, one-touch function (joystick)

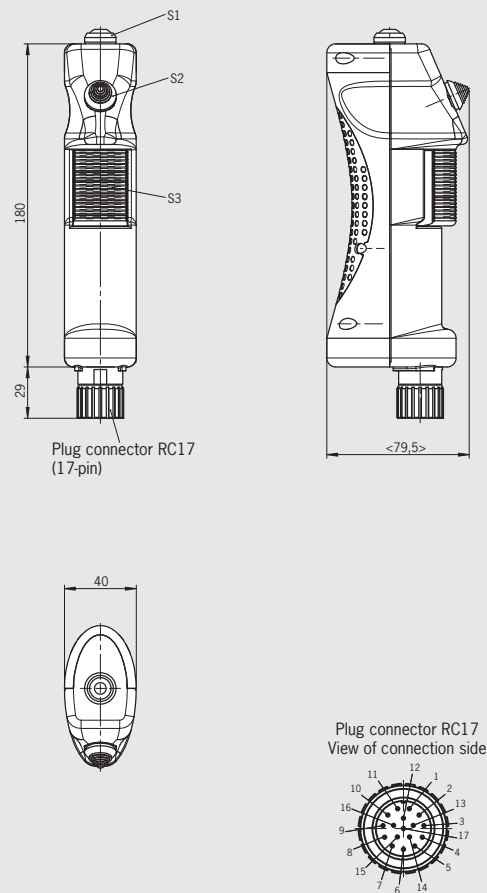

For wiring diagram see page 76
For mating connectors see page 65
For connection cable see page 67

Switching element/function sequence

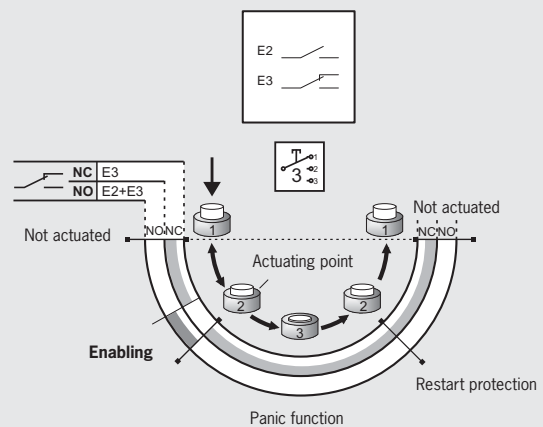
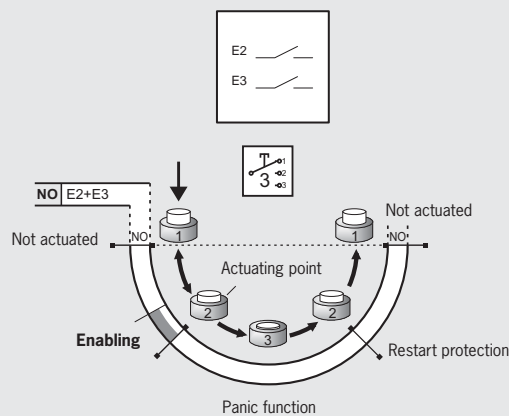

Ordering table

Design	Connection	Cable lengths	Version	Order No./item
ZSM	HAN Q17 Plug connector (18-pin)	1.25 ... 3.1 m coiled	Enabling switch with 2 NO contacts (S4), vibration signal, yellow LED indicator (V1), buttons +/- (S3/S2), reset-button (S1)	106670 ZSM2300-106670
	RC17 Plug connector (17-pin)	without cable	Enabling switch with 1 NO contact and 1 changeover contact (S3), one-touch function (S2), black pushbutton (S1)	106374 ZSM2300-106374

Selection table for enabling switches ZSA, ZSB and ZSR

Design	
G1	Housing G1 (black)
G2	Housing G2 (yellow)
G3	Housing G3 (yellow)
Function	
3	3-stage (OFF - enabling - OFF)
Connection	
c	Tab connector, screw terminal, flying lead
SS4	Plug connector 3-pin + PE
SVM5	Plug connector M12 5-pin
C16	Plug connector 6-pin + PE
HAN10	Plug connector 10-pin + PE
RC12	Plug connector 11-pin + PE
BS12	Plug connector 12-pin
RC17	Plug connector 17-pin
UT23	Plug connector 23-pin
Additional elements	
Z	Additional elements, e.g. buttons, LEDs, key-operated rotary switches, selector switches, etc.

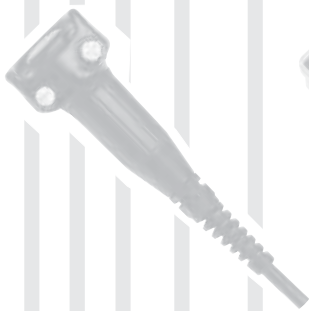

Enabling switch ZSB
Housing G1

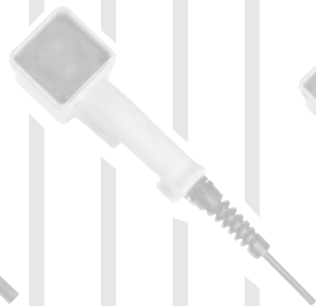

Enabling switch ZSR
Housing G2



Enabling switch ZSB
Housing G3

Design			Stages	Connection										Z	Page
G1	G2	G3	3	c	SS4	SVM5	C16	HAN10	RC12	BS12	RC17	UT23	Z		
●			●	●											32 - 34
●			●		●	●									35
●			●				●	●	●						36
●			●						●				●		37
●			●						●		●				38
●			●	●									●		39
●			●						●	●	●			●	40
	●		●	●											41/42
		●	●	●										●	43
		●	●	●					●					●	44
		●	●	●										●	45
		●	●	●							●		●		46/47



Enabling switch ZSA

- ▶ Housing G1
- ▶ 3-stage function
- ▶ Single or dual-channel version
- ▶ Connection cable straight or coiled
- ▶ Wall holder optional



ZSA, 3-stage function

Flying lead

Dimension drawings

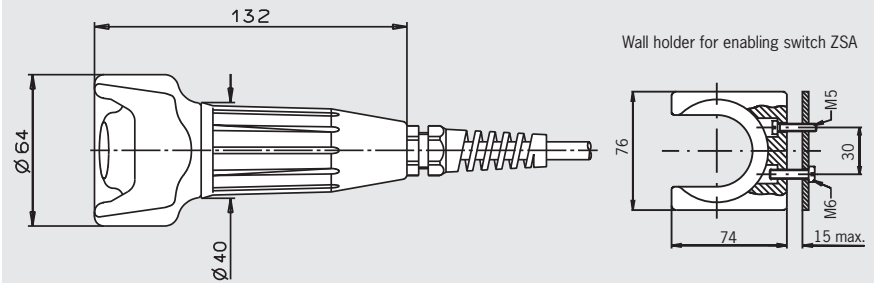

3-stage function

Enabling function is only active in the second stage (middle position, actuating point). If the button is released or pushed further (panic function), the enabling is removed (dependent on the wiring, see function sequence).

Cable

The high-quality connection cables (individual screening of the safety contacts) are available straight or coiled.

Switching elements (see also page 8)

- ▶ **111** 1 NO + 1 NC ⊕ + 1 NC
- ▶ **121** 1 NO + 2 NC ⊕ + 1 NC
- ▶ **210** 2 NO + 1 NC ⊕
- ▶ **220** 2 NO + 2 NC ⊕

Cable lengths (coiled cable pulled out straight)

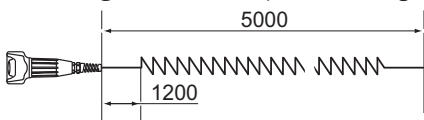

Wiring diagrams/function sequence

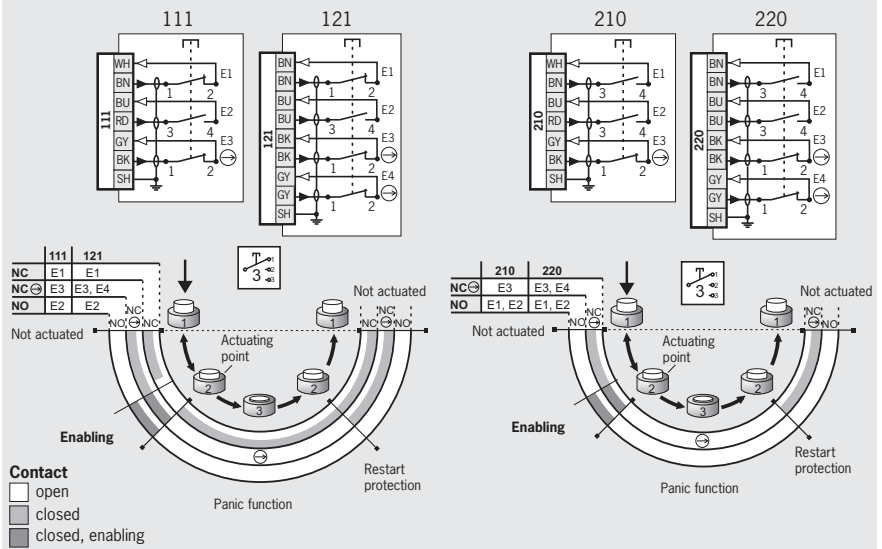

Ordering table

Design	Connection/ cross-section	Cable length	Version	Switching element			
				111: 1 NO + 1 NC ⊕ + 1 NC	121: 1 NO + 2 NC ⊕ + 1 NC	210: 2 NO + 1 NC ⊕	220: 2 NO + 2 NC ⊕
G1 3-stage	Flying lead 6 x 0.34 mm ²	1.5 m straight	incl. wall holder	057089 ZSA2A1L15AC1689	-	On request	-
		2 m straight		-	-	099371 ZSA2A2G02A	-
		2.5 m straight	incl. wall holder	072728 ZSA2A1L25AC1689	-	On request	-
		5 m straight		055402 ZSA2A1G05A	-	055406 ZSA2A2G05A	-
		5 m coiled		055404 ZSA2A1S05A	-	055408 ZSA2A2S05A	-
		10 m straight		055403 ZSA2A1G10A	-	055407 ZSA2A2G10A	-
		15 m straight		On request	-	057007 ZSA2A2G15A	-
		20 m straight		On request	-	075807 ZSA2A2G20A	-
		25 m straight		On request	-	078939 ZSA2A2G25A	-
		G1 3-stage	Flying lead 8 x 0.34 mm ²	2.5 m straight	incl. wall holder	-	On request
5 m straight				-	070784 ZSA2A3G05A	-	070764 ZSA2A4G05A
5 m coiled				-	070786 ZSA2A3S05A	057010 ZSA2A2S05AC1643	070766 ZSA2A4S05A
10 m straight				-	070785 ZSA2A3G10A	-	070765 ZSA2A4G10A
20 m straight				-	On request	-	073300 ZSA2A4G20A



Enabling switch ZSA

- ▶ Housing G1
- ▶ 3-stage function
- ▶ Single or dual-channel version
- ▶ Connection cable straight or coiled
- ▶ Plug connector optional
- ▶ Direct connection to safety switch optional
- ▶ Wall holder optional
- ▶ Increased actuating force optional



3-stage function

Enabling function is only active in the second stage (middle position, actuating point). If the button is released or pushed further (panic function), the enabling is removed (dependent on the wiring, see function sequence)

Cable

The high-quality connection cables (individual screening of the safety contacts) are available straight or coiled.

Suitable for direct connection to safety switch
This enabling switch can be connected directly to a safety switch (TZ...C1662) (see catalog for safety switches with metal housing).

Switching elements (see also page 8)

- ▶ **1110** 1 NO/NC ¹⁾
- ▶ **1210** 1 NO/NC ¹⁾ + 1 NO
- ▶ **2210** 1 NO/NC ¹⁾
- 1 NO (additional monitoring contact)
- ▶ **2220** 2 NO/NC ¹⁾

Cable lengths (coiled cable pulled out straight)

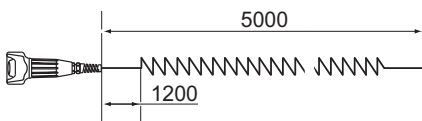

ZSA, 3-stage function

Flying lead

Dimension drawings

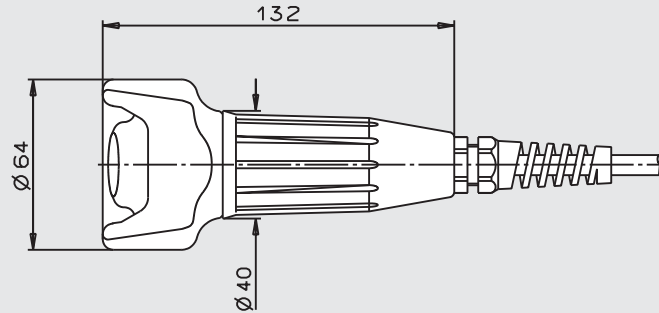

Wiring diagrams/function sequence

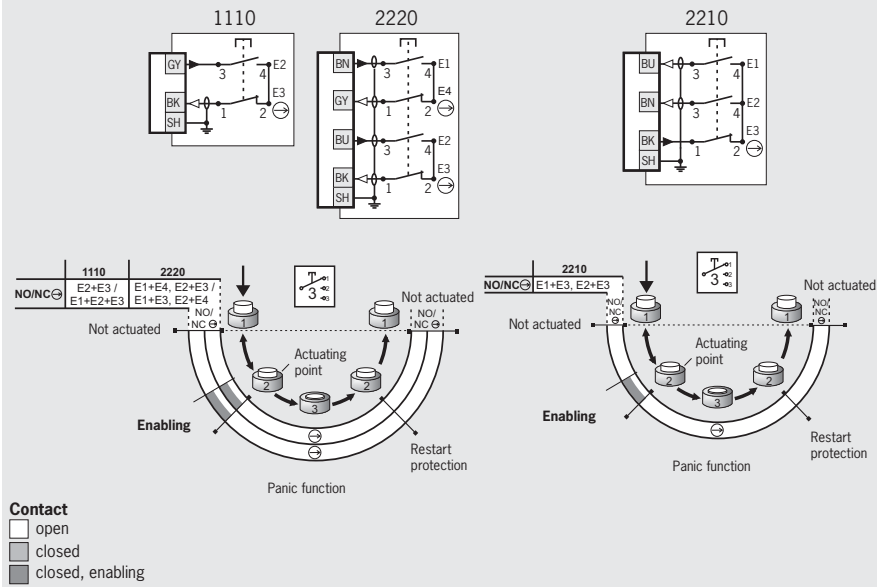

Ordering table

Design	Connection/ cross-section	Cable length	Version	Switching element		
				1110: 1 NO/NC ¹⁾	2210: 1 NO/NC ¹⁾ +1 NO	2220: 2 NO/NC ¹⁾
G1 3-stage	Flying lead 8 x 0.34 mm ²	5 m straight		On request	On request	072961 ZSA2B4G05A
		5 m coiled		On request	On request	085118 ZSA2B4S05A
		10 m straight	Increased actuating force	-	On request	On request
	Flying lead 3 x 0.75 mm ²	5 m straight		On request	055410 ZSA2B2G05A	-
		10 m straight		On request	055411 ZSA2B2G10A	-

1) Only closed in middle position, a normally open contact and a positively driven contact are combined internally.



ZSA, 3-stage function Plug connectors

Dimension drawings

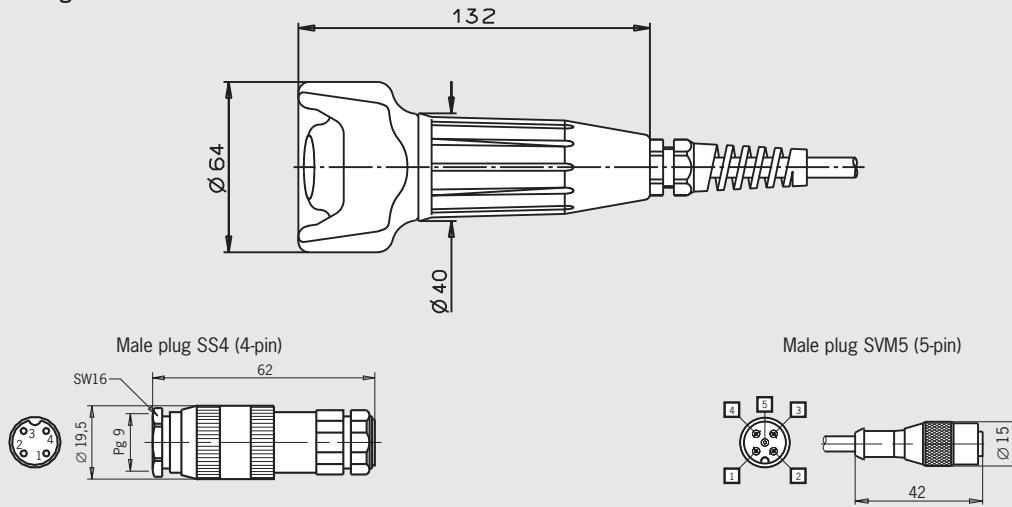

For mating connectors see page 64

View of connection side

Wiring diagrams/function sequence

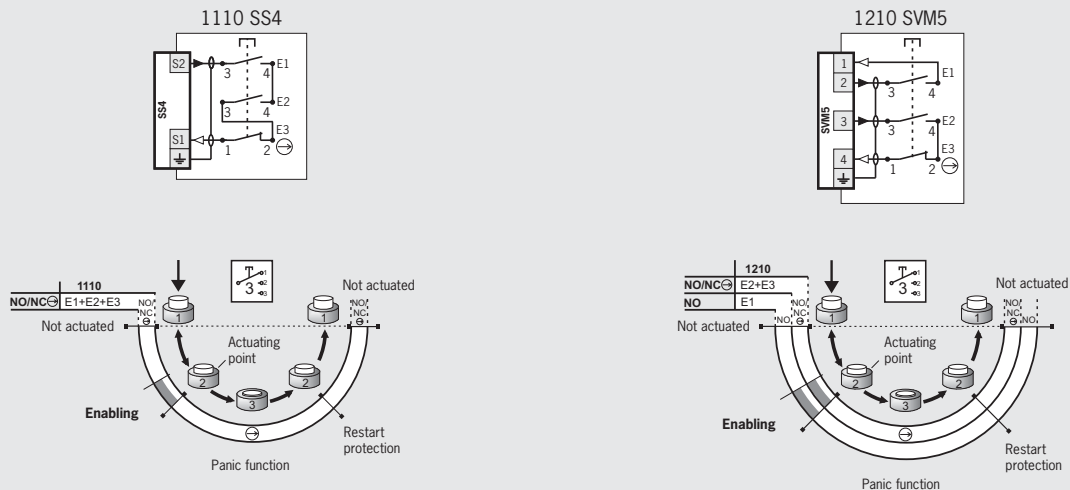

Contact
 open
 closed
 closed, enabling

Ordering table

Design	Connection	Cable length	Version	Switching element	
				1110: 1 NO/NC \ominus 1)	1210: 1 NO/NC \ominus 1) +1 NO
G1 3-stage	SS4 Plug connectors (4-pin)	5 m straight	Direct connection to TZ...C1662 with plug BD4	057097 ZSA2B2G05B-C1662	-
		10 m straight	Direct connection to TZ...C1662 with plug BD4	-	-
	SVM5 Plug connectors (5-pin)	15 m straight		On request	072870 ZSA2B2G15CC1926
		25 m straight		On request	-

1) Only closed in middle position, a normally open contact and a positively driven contact are combined internally.



Enabling switch ZSA

- ▶ Housing G1
- ▶ 3-stage function
- ▶ Single or dual-channel version
- ▶ Straight connection cable
- ▶ Plug connectors
- ▶ Direct connection to safety switch optional
- ▶ Increased actuating force optional



3-stage function

Enabling function is only active in the second stage (middle position, actuating point). If the button is released or pushed further (panic function), the enabling is removed (dependent on the wiring, see function sequence).

Cable

The high quality connection cables (individual screening of the safety contacts) are available straight.

Suitable for direct connection to safety switch

This enabling switch can be connected directly to a safety switch (TZ...C1803) (see catalog for safety switches with metal housing).

Increased actuating force

A higher force is required on pressing through from stage 2 (enabling) to stage 3 (pressed through 'panic function').

Switching elements (see also page 8)

- ▶ **210** 2 NO + 1 NC ⊕
- ▶ **220** 2 NO + 2 NC ⊕
- ▶ **2210** 1 NO/NC ⊕¹⁾
1 NO (additional monitoring contact)
- ▶ **2220** 2 NO/NC ⊕¹⁾

ZSA, 3-stage function

Plug connectors

Dimension drawings

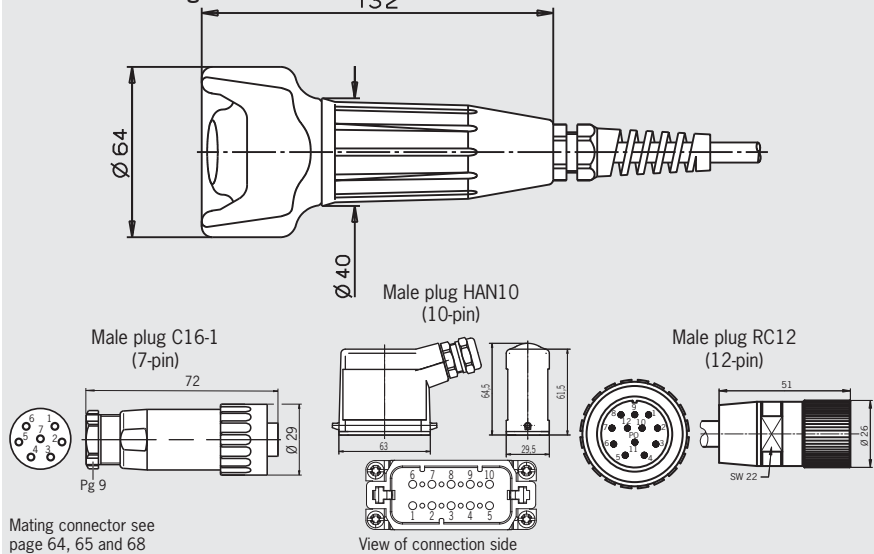

Wiring diagrams/function sequence

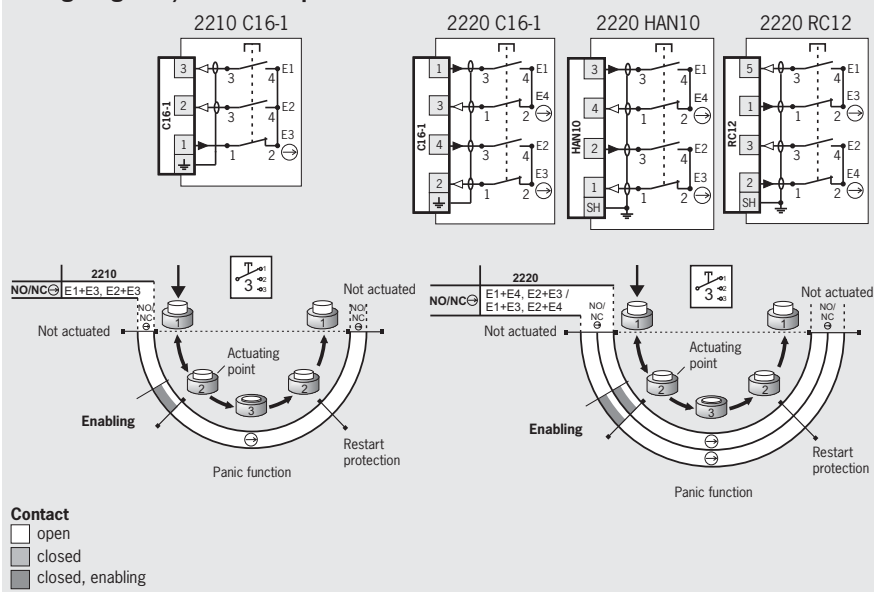

Ordering table

Design	Connection	Cable length	Version	Switching element	
				2210: 1 NO/NC ⊕ ¹⁾ +1 NO	2220: 2 NO/NC ⊕ ¹⁾
G1 3-stage	C16-1 ²⁾ Plug connectors (7-pin)	10 m straight		057100 ZSA2B2G10B	070788 ZSA2B4G10B
		20 m straight		On request	-
	HAN10 Plug connectors (10-pin)	10 m straight	Increased actuating force. Screen on plug on housing	On request	077489 ³⁾ ZSA2B4G10CC1830
		5 m straight	Direct connection to TZ...C1803, screen on connector housing	On request	092141 ^{3) 4)} ZSA092141C2038
	10 m straight	On request		097567 ^{3) 4)} ZSA097567C2038	
	15 m straight	On request		099495 ^{3) 4)} ZSA099459C2038	
	25 m straight	On request		100873 ^{3) 4)} ZSA0100873C2038	

1) Only closed in middle position, a normally open contact and a positively driven contact are combined internally.
2) Enabling switch connector compatible with safety switch NZ...VZ.C1420 or NZ...VZ.C1701 (see catalog for safety switches with metal housing).
3) No BG type examination
4) No cULus type examination

ZSA, 3-stage function Plug connectors

Dimension drawings

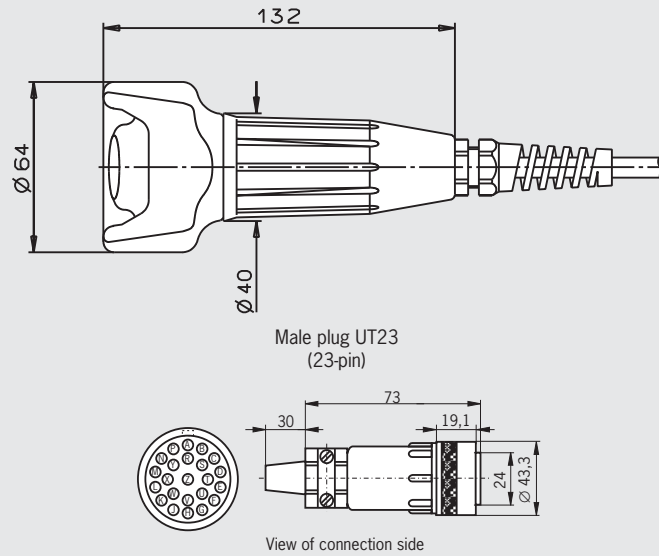

For mating connectors see page 66

Wiring diagrams/function sequence

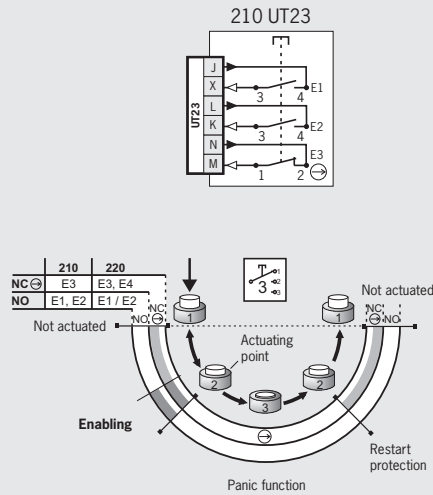

Contact
 open
 closed
 closed, enabling

Ordering table

Design	Connection	Cable length	Switching element	
			210: 2 NO + 1 NC	220: 2 NO + 2 NC
G1 3-stage	UT23 Plug connectors (23-pin)	1.2 m straight	070731 ZSA2A2L12CC1725	On request



Enabling switches ZSA and ZSB

- ▶ Housing G1
- ▶ 3-stage function
- ▶ Dual-channel version
- ▶ Straight connection cable
- ▶ Plug connector optional
- ▶ LED and/or buttons optional



3-stage function

Enabling function is only active in the second stage (middle position, actuating point). If the button is released or pushed further (panic function), the enabling is removed (dependent on the wiring, see function sequence).

Cable

The high quality connection cables (individual screening of the safety contacts) are available straight.

LEDs

The LEDs are used for visual feedback direct at the enabling switch.

+ and - buttons

These buttons can be configured individually. For example, for moving axes in positive or negative direction.

Switching elements (see also page 8)

- ▶ 210 2 NO + 1 NC ⊖
- ▶ 220 2 NO + 2 NC ⊖
- ▶ 2220 2 NO/NC ⊖ ¹⁾

ZSA, 3-stage function Plug connectors

Dimension drawings

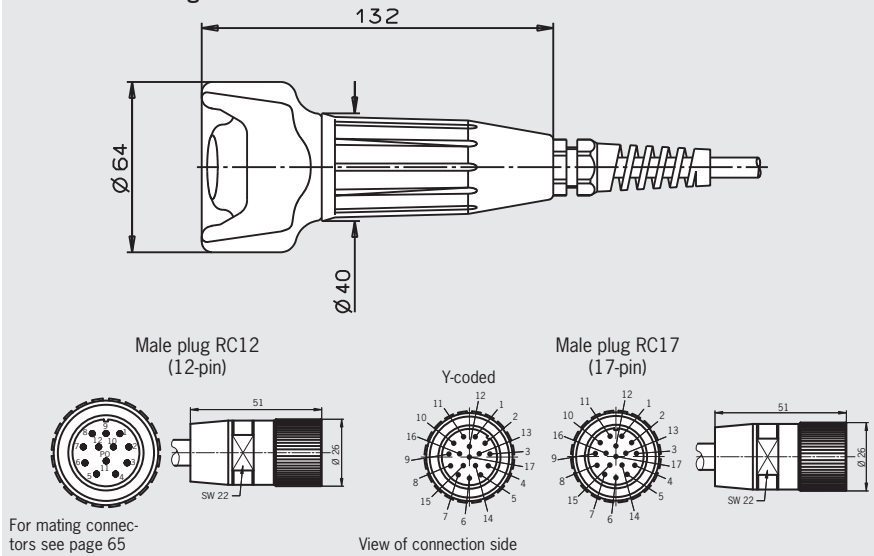

Wiring diagrams/function sequence

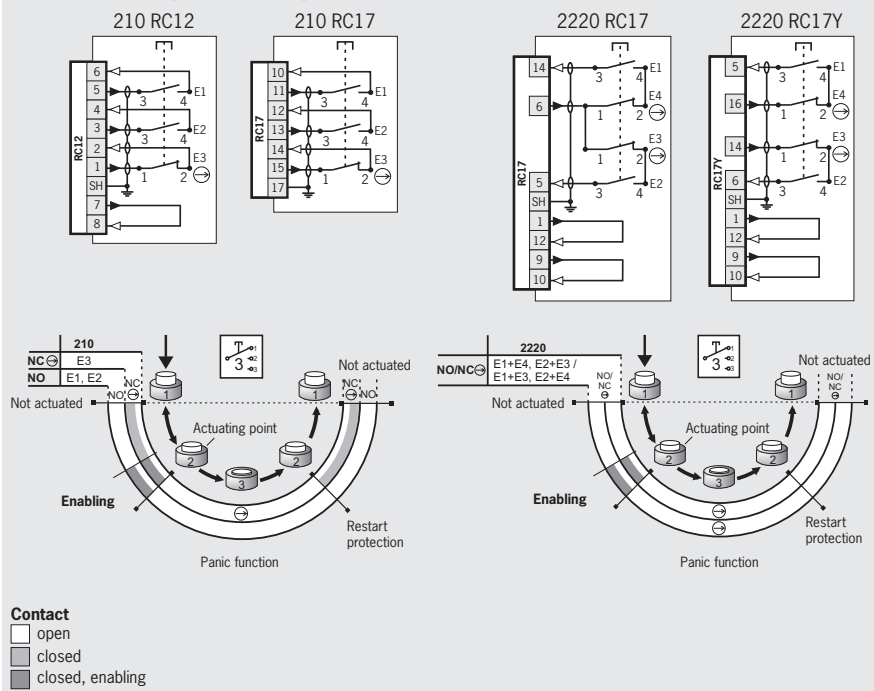

Ordering table

Design	Connection	Cable length	Version	Switching element	
				210: 2 NO + 1 NC ⊖	2220: 2 NO/NC ⊖ ¹⁾
G1 3-stage	RC12 Plug connectors (12-pin)	5 m straight	Screen on connector housing	073289 ZSA2AG05CC1770	On request
	RC17 Plug connectors (17-pin)	5 m straight	Suitable for Siemens panel PP031 (1-channel), screen on connector housing	070741 ZSA2AG05CC1714	On request
				092738 ZSA2A4G05C-C2041	
	RC17 Plug connectors Y-coded (17-pin)	5 m straight	Suitable for Siemens panel PP012 and PP031 (2-channel), screen on connector housing	On request	091547 ZSA2A4G05C-C2032

1) Only closed in middle position, a normally open contact and a positively driven contact are combined internally.



ZSB, 3-stage function Flying lead

Dimension drawings

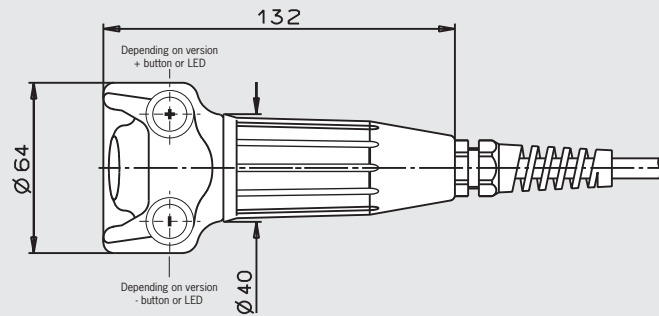

Wiring diagrams/function sequence

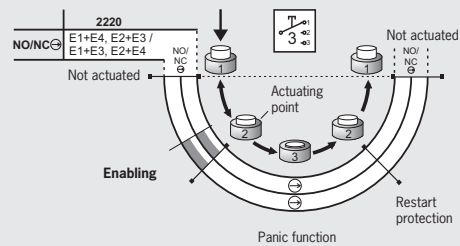
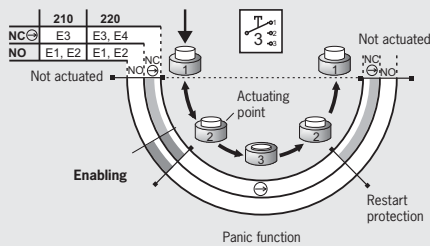
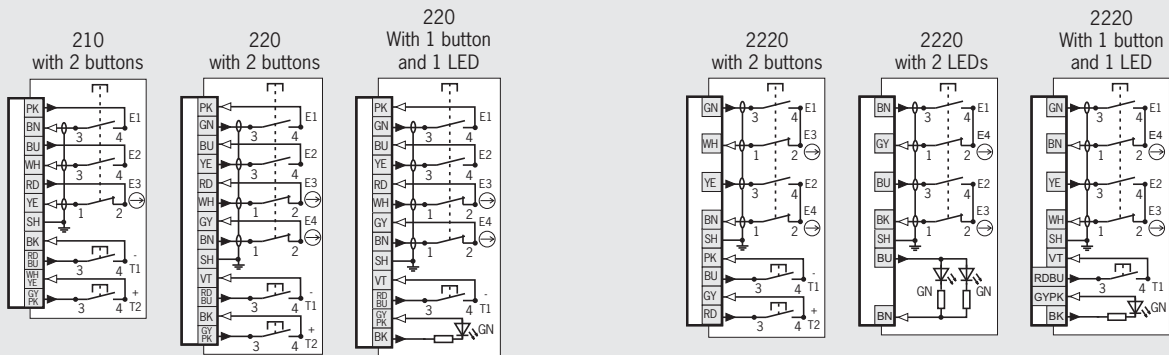

Contact
 open
 closed
 closed, enabling

Ordering table

Design	Connection/ cross-section	Cable length	Version	Switching element		
				210: 2 NO + 1 NC ¹⁾	220: 2 NO + 2 NC ¹⁾	2220: 2 NO/NC ¹⁾
G1 3-stage	Flying lead 8 x 0.34 mm ²	10 m straight	2 LEDs (gn)	On request	On request	086707 ^{2) 3)} ZSA086707C1983
		15 m straight	2 LEDs (gn)	On request	On request	072969 ^{2) 3)} ZSA072969C1983
	Flying lead 8 x 0.5 mm ² + 8 x 0.14 mm ²	5 m straight	1 button, 1 LED (gn)	On request	085126 ^{2) 3)} ZSB085126	106112 ZSB2B4G05A-C2277
		5 m straight	2 buttons (+ and -)	073260 ZSB2A2G05A	083317 ^{2) 3)} ZSB083317	092378 ^{2) 3)} ZSB092378
		10 m straight	2 buttons (+ and -)	073261 ZSB2A2G10A	On request	On request
		15 m straight	2 buttons (+ and -)	095612 ZSB2A2G15A	On request	On request
		20 m straight	2 buttons (+ and -)	On request	096900 ³⁾ ZSB096900	On request
		8 m coiled	2 buttons (+ and -)	On request	103161 ³⁾ ZSB103161	On request
		22 m coiled	2 buttons (+ and -)	On request	On request	109136 ZSB2B4S22A

1) Only closed in middle position, a normally open contact and a positively driven contact are combined internally.
 2) No BG type examination
 3) No cULus type examination



ZSB, 3-stage function
Plug connectors

Dimension drawings

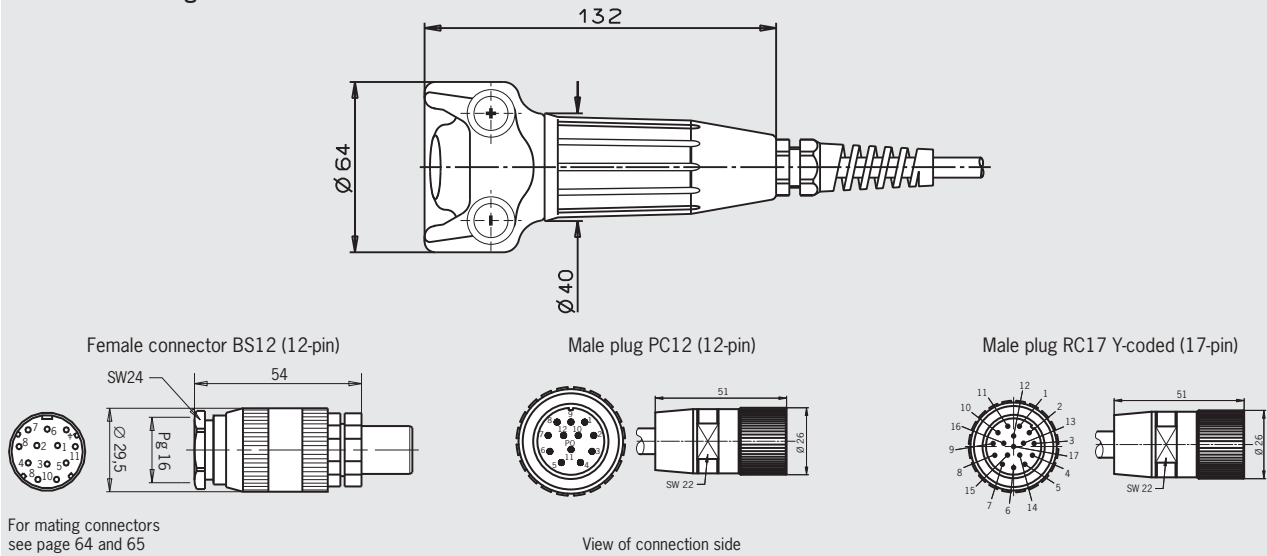

For mating connectors see page 64 and 65

Wiring diagrams/function sequence

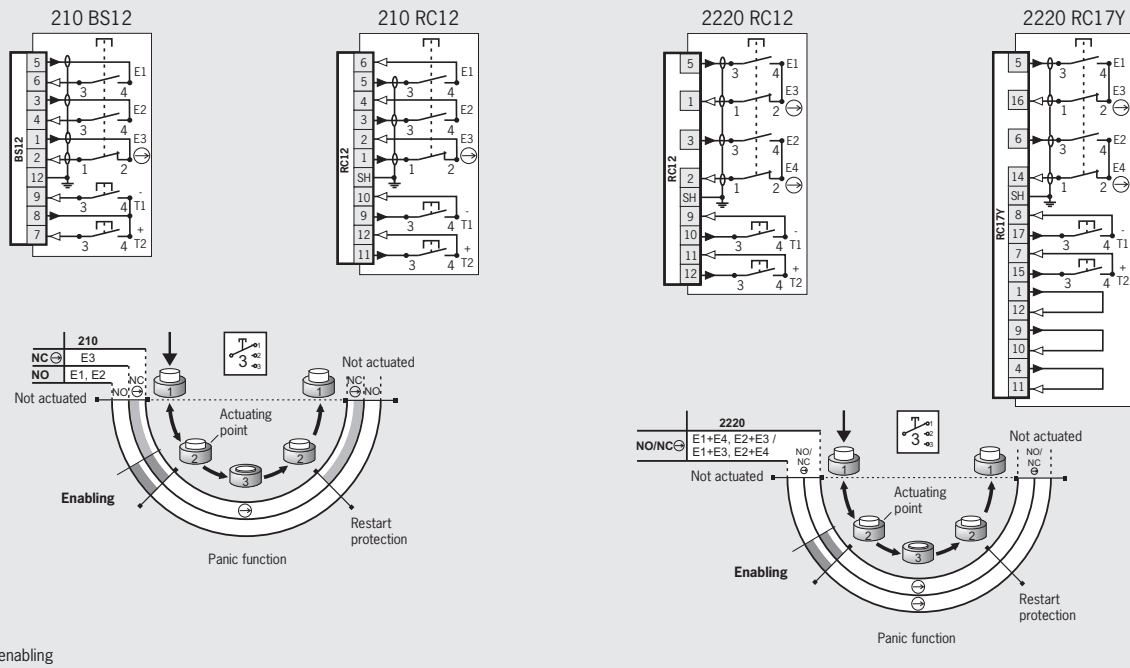

Ordering table

Design	Connection	Cable length	Version	Switching element	
				210: 2 NO + 1 NC ↻	2220: 2 NO/NC ↻ 1)
G1 3-stage	BS12 Plug connectors (12-pin)	5 m straight	2 buttons (+ and -)	079832 2) 3) ZSB079832	On request
	RC12 Plug connectors (12-pin)	5 m straight	2 buttons (+ and -), screen on connector housing	073264 ZSB2A2G05C	On request
		5 m straight	2 buttons (+ and -), direct connection TZ...C1803, screen on connector housing	On request	077040 2) 3) ZSB077040
		10 m straight	2 buttons (+ and -), screen on connector housing	073265 ZSB2A2G10C	On request
	RC17 Plug connectors Y-coded (17-pin)	5 m straight	2 buttons (+ and -), screen on connector housing	On request	092996 2) ZSB2B4G05C-C2044

1) Only closed in middle position, a normally open contact and a positively driven contact are combined internally.
2) No BG type examination
3) No cULus type examination



Enabling switch ZSR

- ▶ 3-stage function
- ▶ Single or dual-channel version
- ▶ Housing G2
- ▶ Straight connection cable
- ▶ Plug connector optional
- ▶ Including holder



3-stage function

Enabling function is only active in the second stage (middle position, actuating point). If the button is released or pushed further (panic function), the enabling is removed (dependent on the wiring, see function sequence).

Cable

The high quality connection cables (individual screening of the safety contacts) are available straight.

Switching elements (see also page 8)

- ▶ **111** 1 NO + 1 NC ⊕ + 1 NC
- ▶ **210** 2 NO + 1 NC ⊕
- ▶ **220** 2 NO + 2 NC ⊕
- ▶ **1110** 1 NO/NC ⊕¹⁾
- ▶ **2210** 1 NO/NC ⊕¹⁾
1 NO (additional monitoring contact)

Cable lengths (coiled cable pulled out straight)

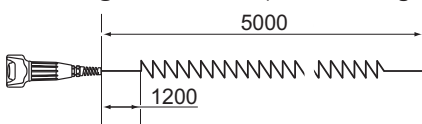

ZSR, 3-stage function

Flying lead

Dimension drawings

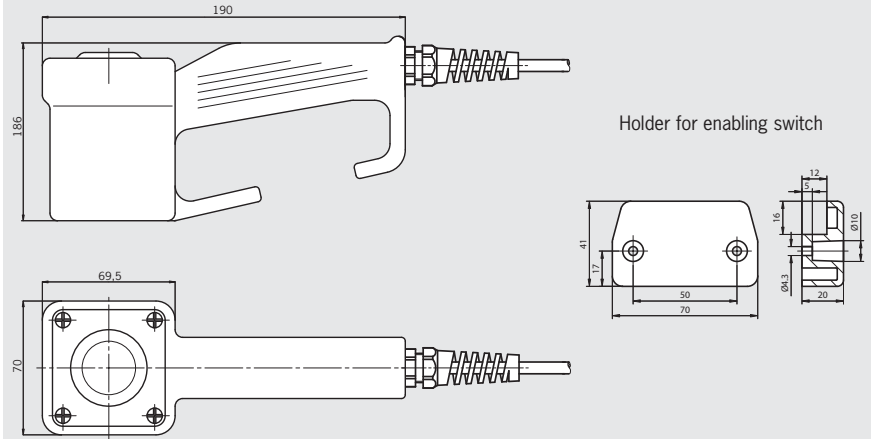

Wiring diagrams/function sequence

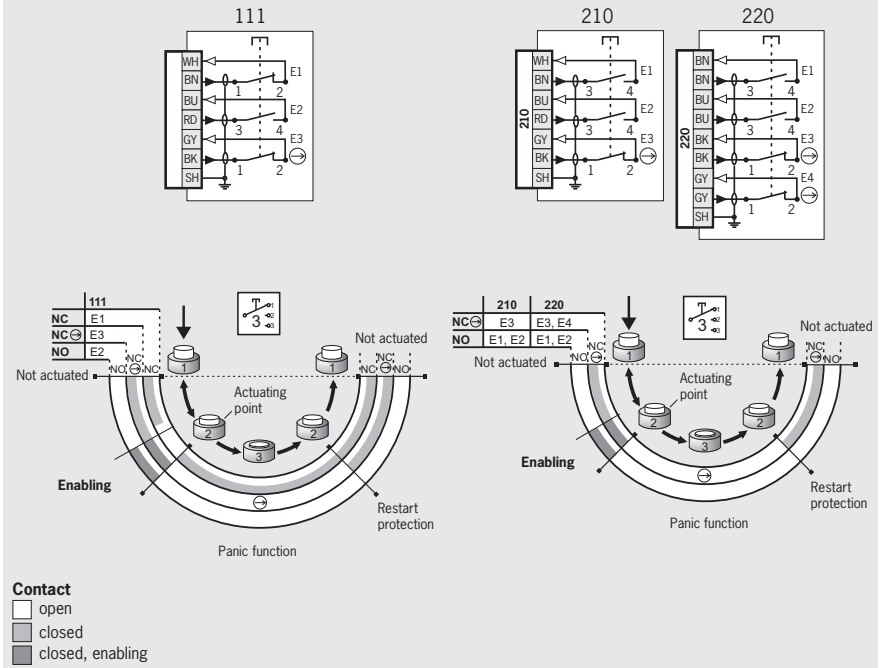

Ordering table

Design	Connection/ cross-section	Cable length	Switching element		
			111: 1 NO + 1 NC ⊕ + 1 NC	210: 2 NO + 1 NC ⊕	220: 2 NO + 2 NC ⊕
G2 3-stage	Flying lead 6 x 0.34 mm ²	5 m straight	055423 ZSR2A1G05A	055427 ZSR2A2G05A	-
		10 m straight	055424 ZSR2A1G10A	055428 ZSR2A2G10A	-
		5 m coiled	055425 ZSR2A1S05A	055429 ZSR2A2S05A	-
	Flying lead 8 x 0.34 mm ²	5 m straight	-	-	097609 ZSR2A4G05A
		5 m coiled	-	-	104085 ZSR2A4S05A

1) Only closed in middle position, a normally open contact and a positively driven contact are combined internally.



ZSR, 3-stage function Flying lead

Dimension drawings

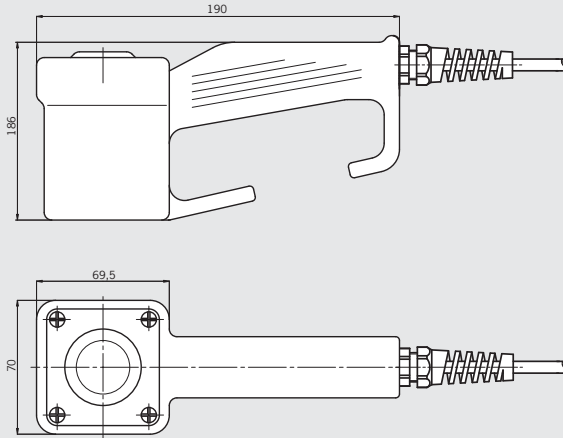

Holder for enabling switch

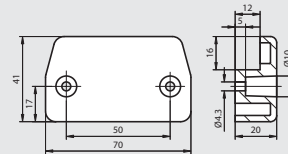

Wiring diagrams/function sequence

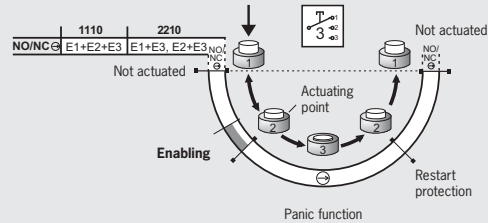
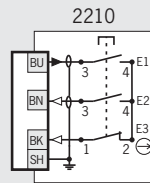

- Contact**
- open
 - closed
 - closed, enabling

Ordering table

Design	Connection/ cross-section	Cable length	Switching element	
			1110: 1 NO/NC ¹⁾	2210: 1 NO/NC ¹⁾ + 1 NO
G2 3-stage	Flying lead 3 x 0.75 mm ²	5 m straight	On request	055431 ZSR2B2G05A
		10 m straight	On request	055432 ZSR2B2G10A

1) Only closed in middle position, a normally open contact and a positively driven contact are combined internally.

Enabling switch ZSB

- ▶ 3-stage function
- ▶ Dual-channel version
- ▶ Housing G3
- ▶ Coiled connection cable
- ▶ Two illuminated buttons
- ▶ Including holder



3-stage function

Enabling function is only active in the second stage (middle position, actuating point). If the button is released or pushed further (panic function), the enabling is removed (dependent on the wiring, see function sequence).

Cable

The high-quality connection cables (individual screening of the safety contacts) are available coiled.

Illuminated + and - buttons

These buttons can be configured individually. For example, for moving axes in positive or negative direction.

Switching elements (see also page 8)

- ▶ **210** 2 NO + 1 NC

Cable lengths (coiled cable pulled out straight)

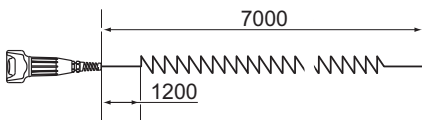

ZSB, 3-stage function Flying lead

Dimension drawings

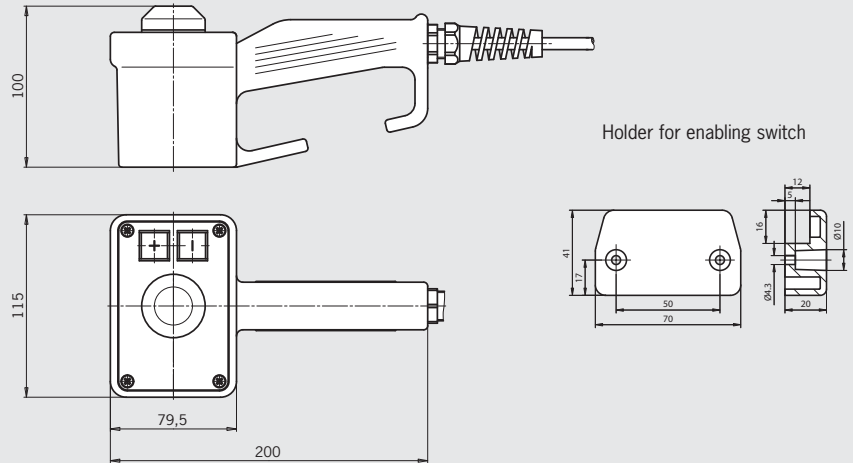

Wiring diagrams/function sequence

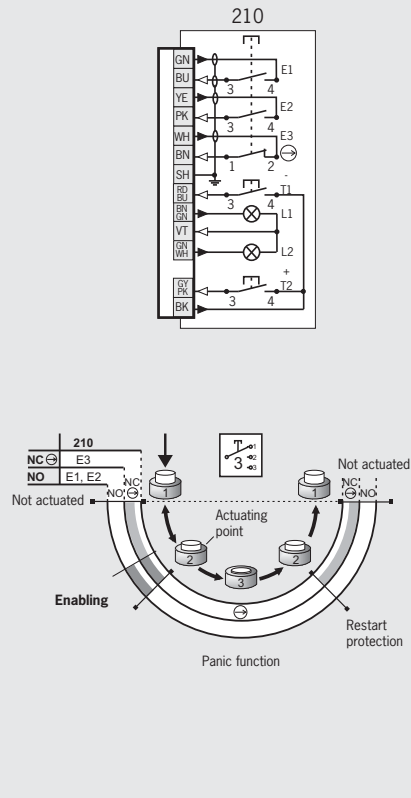

Ordering table

Design	Connection/ cross-section	Cable length	Version	Switching element
				210: 2 NO + 1 NC
G3 3-stage	Flying lead 8 x 0.5 mm ² + 8 x 0.14 mm ²	7 m coiled	2 illuminated buttons (+ and -)	054784 ZSB054784

Enabling switch ZSB

- ▶ 3-stage function
- ▶ Dual-channel version
- ▶ Housing G3
- ▶ Connection cable straight or coiled
- ▶ Plug connectors
- ▶ Two illuminated buttons



3-stage function

Enabling function is only active in the second stage (middle position, actuating point). If the button is released or pushed further (panic function), the enabling is removed (dependent on the wiring, see function sequence).

Cable

The high-quality connection cables (individual screening of the safety contacts) are available straight or coiled.

Illuminated + and - buttons

These buttons can be configured individually. For example, for moving axes in positive or negative direction.

Switching elements (see also page 8)

- ▶ 220 2 NO + 2 NC ⊖
- ▶ 2220 2 NO/NC ⊖¹⁾

Cable lengths (coiled cable pulled out straight)

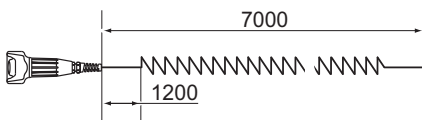

ZSB, 3-stage function

Plug connectors

Dimension drawings

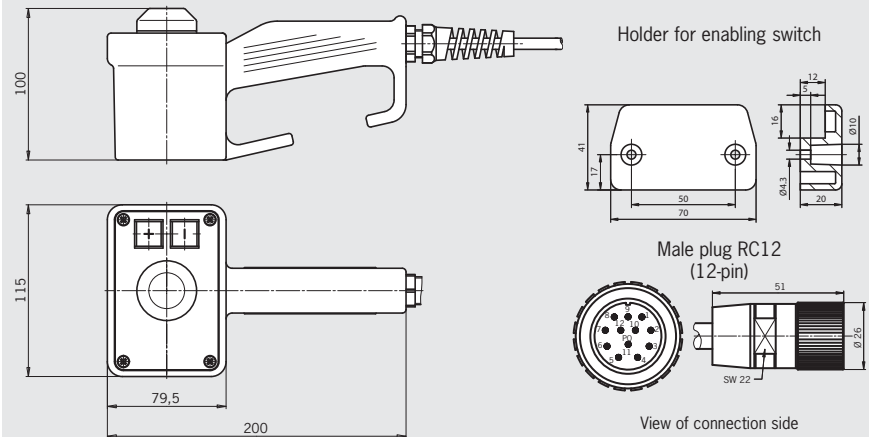

For mating connectors see page 65

Wiring diagrams/function sequence

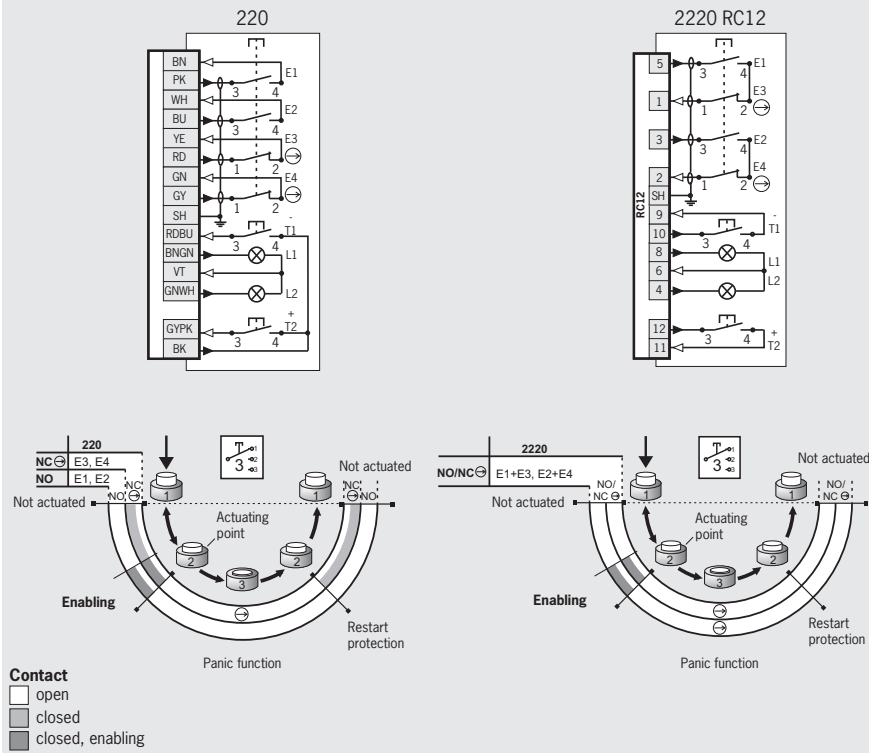

Ordering table

Design	Connection/ cross-section	Cable length	Version	Switching element	
				220: 2 NO + 2 NC ⊖	2220: 2 NO/NC ⊖ ¹⁾
G3 3-stage	Flying lead 4 x 0.5 mm ² + 4 x 0.5 mm ² + 8 x 0.14 mm ²	7 m coiled	2 illuminated buttons (+ and -)	100570 ZSB100570	On request
	RC12 Plug connectors (12-pin)	5 m straight	2 illuminated buttons (+ and -)	-	077029 ZSB077029
		12 m straight	2 illuminated buttons (+ and -)	-	085058 ZSB085058

1) Only closed in middle position, a normally open contact and a positively driven contact are combined internally.

Enabling switch ZSB

- ▶ 3-stage function
- ▶ Dual-channel version
- ▶ Housing G3
- ▶ Connection cable straight or coiled
- ▶ Plug connectors
- ▶ Two illuminated buttons
- ▶ Key-operated rotary switch or selector switch optional
- ▶ Including holder



3-stage function

Enabling function is only active in the second stage (middle position, actuating point). If the button is released or pushed further (panic function), the enabling is removed (dependent on the wiring, see function sequence).

Cable

The high-quality connection cables (individual screening of the safety contacts) are available straight or coiled.

Illuminated + and - buttons

These buttons can be configured individually. For example, for moving axes in positive or negative direction.

Key-operated rotary switch

For individual use, e.g. as operating mode selector switch.

Selector switch (12-stage)

For the selection of different axes or ranges. All outputs are open between the switch positions on the selector switch (break-before-make switching!).

Switching elements (see also page 8)

- ▶ 210 2 NO + 1 NC ⊖
- ▶ 2220 2 NO/NC ⊖¹⁾

ZSB, 3-stage function

Flying lead, key operated rotary switch or selector switch

Dimension drawings

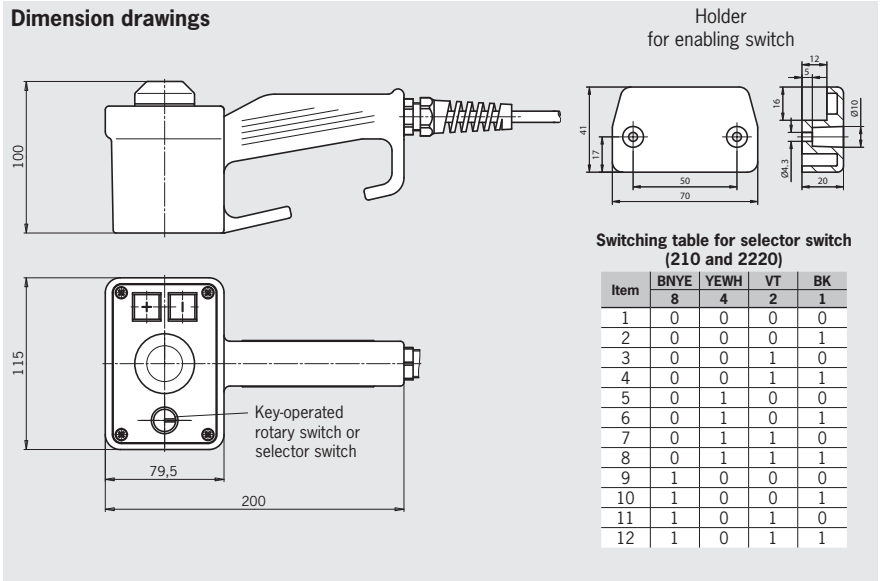

Wiring diagrams/function sequence

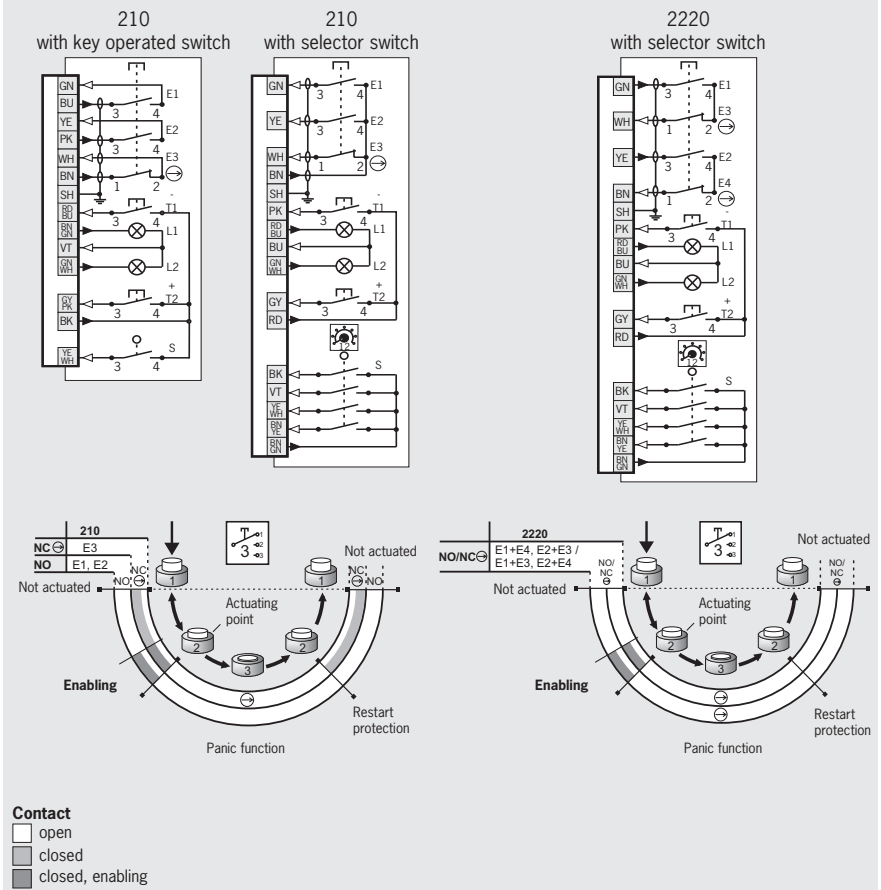

Ordering table

Design	Connection/ cross-section	Cable length	Version	Switching element	
				210: 2 NO + 1 NC ⊖	2220: 2 NO/NC ⊖ ¹⁾
G3 3-stage	Flying lead 8 x 0.5 mm ² + 8 x 0.14 mm ²	3 m straight	2 illuminated buttons (+ and -), 1 key-operated rotary switch	077027 ZSB077027	On request
		10 m straight	2 illuminated buttons (+ and -), 1 selector switch	070894 ZSB070894	087821 ZSB087821

1) Only closed in middle position, a normally open contact and a positively driven contact are combined internally.

Enabling switch ZSB

- ▶ 3-stage function
- ▶ Dual-channel version
- ▶ Housing G3
- ▶ Straight connection cable
- ▶ Plug connectors
- ▶ Two illuminated buttons
- ▶ Key-operated rotary switch
- ▶ Including holder



3-stage function

Enabling function is only active in the second stage (middle position, actuating point). If the button is released or pushed further (panic function), the enabling is removed (dependent on the wiring, see function sequence).

Cable

The high quality connection cables (individual screening of the safety contacts) are available straight.

Illuminated + and - buttons

These buttons can be configured individually. For example, for moving axes in positive or negative direction.

Key-operated rotary switch

For individual use, e.g. as operating mode selector switch.

Switching elements (see also page 8)

- ▶ 210 2 NO + 1 NC ⊖

ZSB, 3-stage function

Plug connector, key-operated rotary switch

Dimension drawings

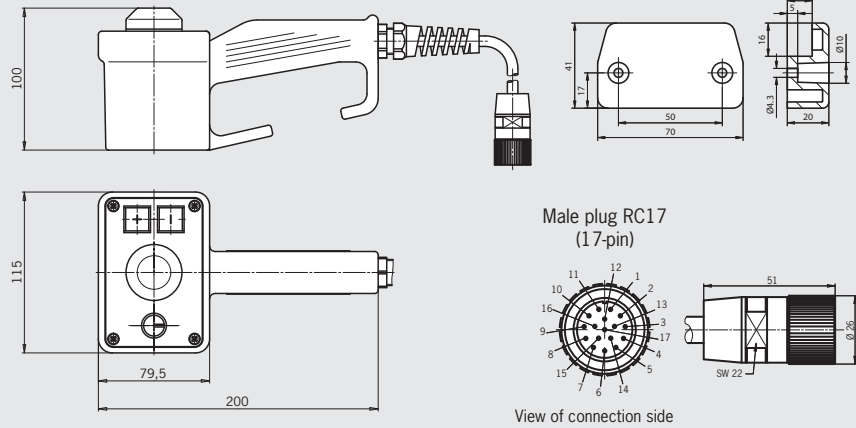

For mating connectors see page 65

Wiring diagrams/function sequence

210 with key operated switch

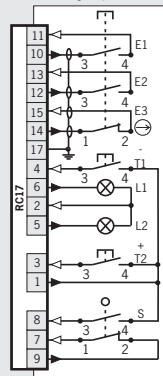

210 with E2-closing

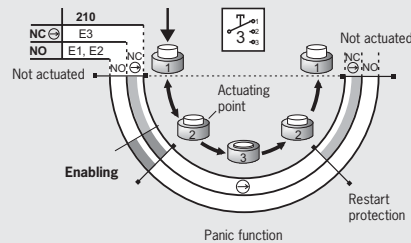
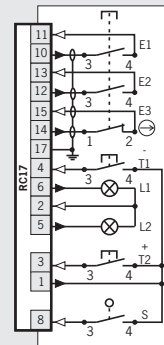

Contact
 □ open
 ■ closed
 ■ closed, enabling

Ordering table

Design	Connection	Cable length	Version	Switching element
				210: 2 NO + 1 NC ⊖
G3 3-stage	RC17 Plug connectors (17-pin)	3 m straight	2 illuminated buttons (+ and -), 1 key-operated rotary switch (1 NO)	070904 ZSB070904
		5 m straight	2 illuminated buttons (+ and -), 1 key-operated rotary switch (1 NO)	072645 ZSB072645
		12 m straight	2 illuminated buttons (+ and -), 1 key-operated rotary switch (1 NO)	072403 ZSB072403
		12 m straight	2 illuminated buttons (+ and -), 1 key-operated rotary switch (1 NO, 1 NC)	090262 ZSB090262

1) No key available

Enabling switch ZSB

- ▶ 3-stage function
- ▶ Dual-channel version
- ▶ Housing G3
- ▶ Straight connection cable
- ▶ Plug connectors
- ▶ Two illuminated buttons
- ▶ Key-operated rotary switch
- ▶ Emergency stop device
- ▶ Including holder



3-stage function

Enabling function is only active in the second stage (middle position, actuating point). If the button is released or pushed further (panic function), the enabling is removed (dependent on the wiring, see function sequence).

Cable

The high quality connection cables (individual screening of the safety contacts) are available straight.

Illuminated + and - buttons

These buttons can be configured individually. For example, for moving axes in positive or negative direction.

Key-operated rotary switch

For individual use, e.g. as operating mode selector switch.

Emergency stop device

Enabling switch with dual-channel emergency stop device on the switch housing, for various wiring concepts. Red emergency stop button.

Switching elements (see also page 8)

- ▶ 2220 2 NO/NC ⊖¹⁾

ZSB, 3-stage function

Plug connector, key-operated rotary switch, emergency stop device

Dimension drawings

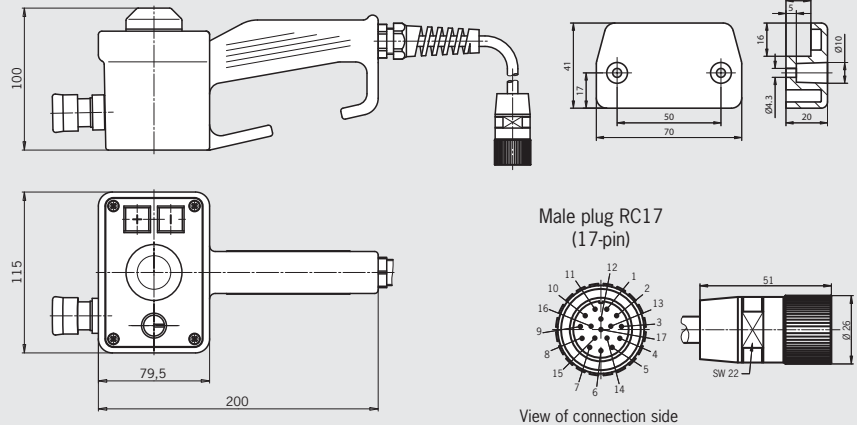

For mating connectors see page 65

Wiring diagrams/function sequence

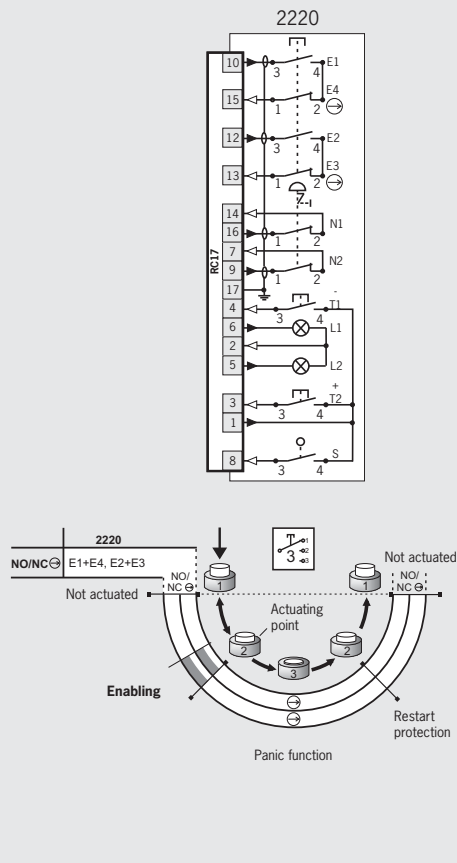

Ordering table

Design	Connection	Cable length	Version	Switching element
				2220: 2 NO/NC ⊖ ¹⁾
G3 3-stage	RC17 Plug connectors (17-pin)	5 m straight	2 illuminated buttons (+ and -), 1 key-operated rotary switch (1 NO), 1 emergency stop device	090489 ZSB090489

Selection table for enabling devices ZSG and ZSA

Design	
E	Built-in version (without cable)
G1	Housing G1 (black)
Function	
3	3-stage (OFF - enabling - OFF)
Connection	
C	Tab connector, screw terminal, flying lead



**Enabling switch ZSG
Housing G3**



**Enabling switch ZSA
Housing G1**

Design	Stages	Connection	Page	
E	G1	2	C	50
●	●	●	●	51

Built-in enabling device ZSG

- ▶ 2-stage function
- ▶ Dual-channel version
- ▶ Suitable, e.g., for hand-held pendant stations HBL



2-stage function ²⁾

Enabling function is active in the second stage (pressed position). When the button is released, the enabling is removed (see function sequence).

Hand-held pendant station HBL

See catalog for hand-held pendant stations.

Switching elements (see also page 8)

- ▶ 20 2 NO

ZSG, 2-stage function ²⁾

Tab connector

Dimension drawings

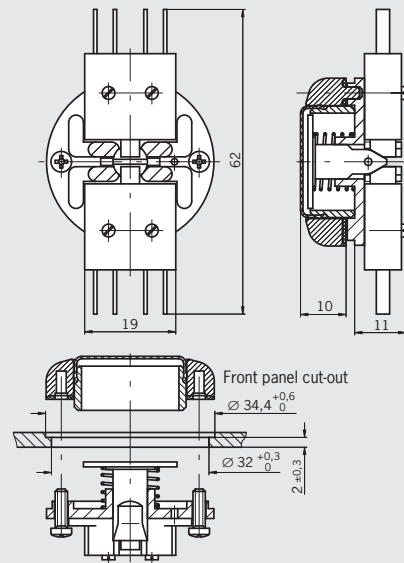

Wiring diagrams/function sequence

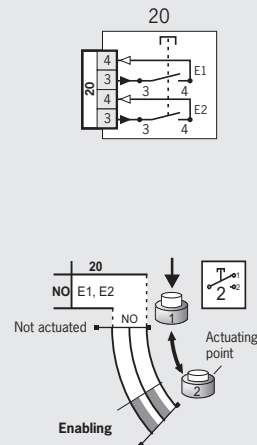

Contact
 open
 closed
 closed, enabling

Ordering table

Design	Connection	Version	Switching element
			20: 2NO
Built-in 2-stage ²⁾ ZSG	Tab connector	Suitable, e.g., for hand-held pendant stations HBL	070793 ZSG1-2

1) Only closed in middle position, a normally open contact and a normally closed contact are combined internally.

2) As per VDI 2854, a device comparable to an emergency stop device must be fitted!



Enabling devices ZSA

- ▶ Housing G1
- ▶ 2-stage function
- ▶ Single or dual-channel version
- ▶ Connection cable straight or coiled
- ▶ Wall holder optional



2-stage function ¹⁾
Enabling function is active in the second stage (pressed position). When the button is released, the enabling is removed (see function sequence).

Cable
The high-quality connection cables (individual screening of the safety contacts) are available straight or coiled.

Switching elements (see also page 8)

- ▶ **10** 1 NO
- ▶ **20** 2 NO
- ▶ **21** 2 NO + 1 NC

Cable lengths (coiled cable pulled out straight)

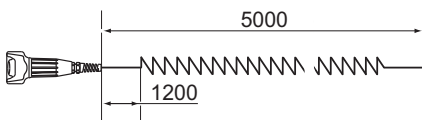

ZSA, 2-stage function ¹⁾ Flying lead

Dimension drawings

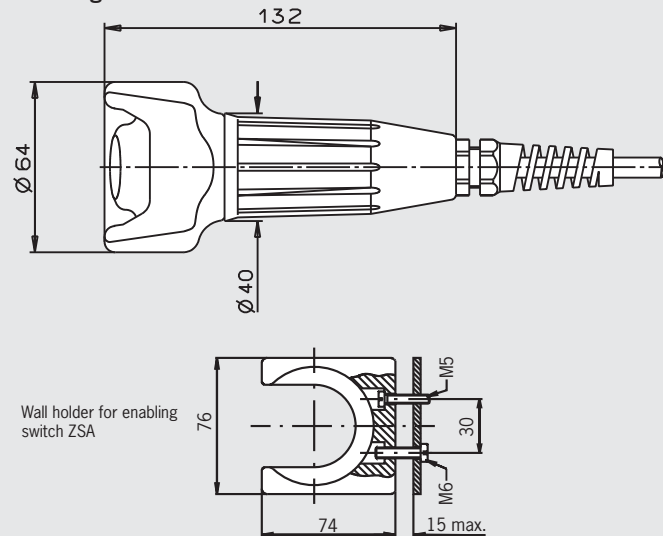

Wiring diagrams/function sequence

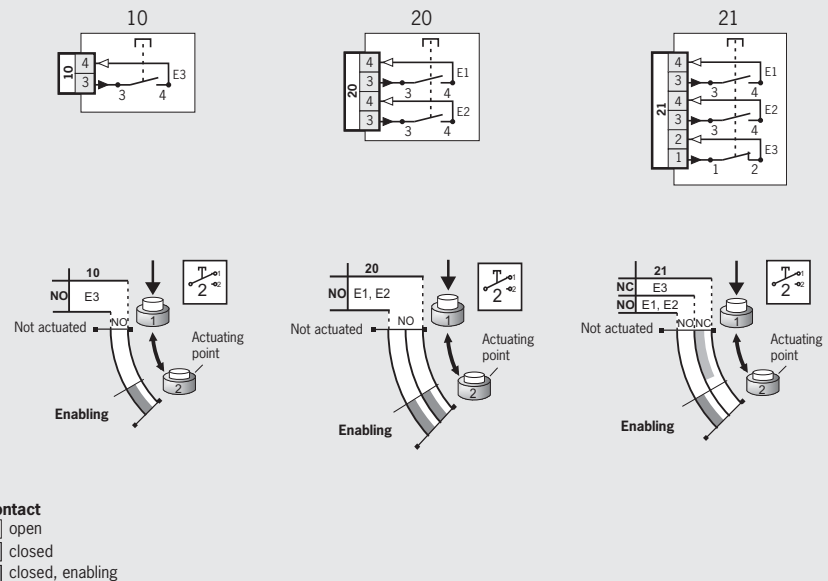

Ordering table

Design	Connection/ cross-section	Cable length	Version	Switching element		
				10: 1NO	20: 2NO	21: 2 NO + 1 NC
G1 2-stage ¹⁾	Flying lead 6 x 0.34 mm ²	2.5 m straight	Incl. wall holder	On request	082557 ZSA1A2L25AC1909	On request
		5 m coiled		On request	On request	094321 ZSA1A2S05A
	Flying lead 3 x 0.75 mm ²	1 m straight	Incl. wall holder	-	-	104231 ZSA1A2G01AC2246
		5 m straight		082524 ZSA1A5G05AC1917	-	-
		7 m straight		-	097909 ZSA1A2G07A	-
		10 m straight		095144 ZSA1A5G10AC1917	-	-

1) As per VDI 2854, a device comparable to an emergency stop device must be fitted!

Kits for enabling switches/enabling devices

Kit for enabling switch ZSM

Kit for enabling switch ZSA

Kit for enabling device ZSA

Kit Enabling switch ZSM	Kit Enabling switch ZSA	Kit Enabling device ZSA	Page
●			54 - 58
	●		59
		●	60

ZSM housing

- ▶ 3-stage function
- ▶ + and – buttons optional
- ▶ Hole for lower stop command device
- ▶ Cable gland included

3-stage function

Enabling function is only active in the second stage (middle position, actuating point). If the button is released or pushed further (panic function), the enabling is removed (dependent on the wiring, see function sequence).

+ and – buttons

These buttons can be individually assigned, e.g. to move axes in positive or negative direction.

ZSM4200-106104, 3-stage function

Dimension drawing

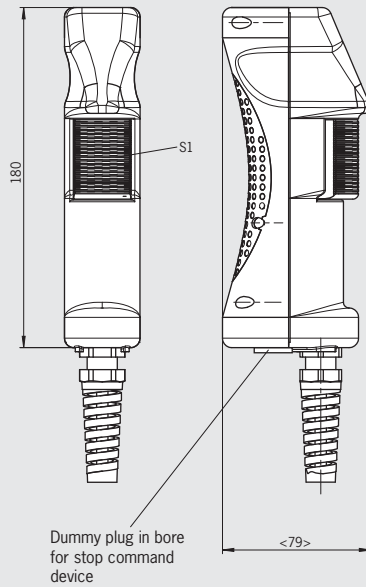

ZSM4200-106105, 3-stage function + and – buttons

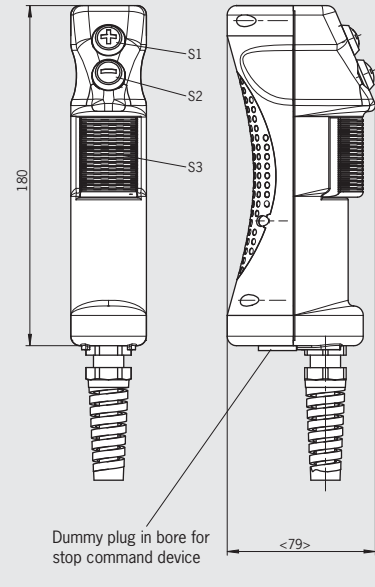

Wiring diagram/function sequence

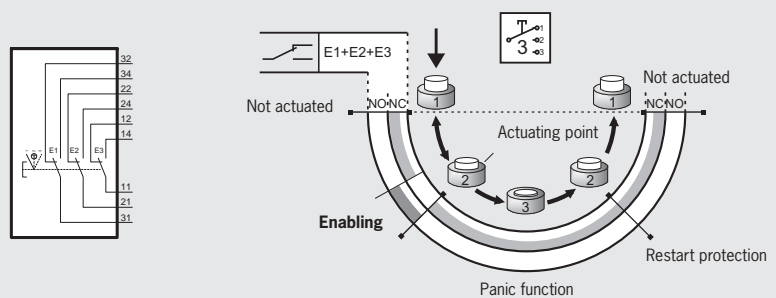

Ordering table

Design	Version	Order No./item
ZSM	Enabling switch with 3 changeover contacts (S1), cable gland included	106104 ZSM4200-106104
	Enabling switch with 3 changeover contacts (S3), +/– buttons with one NO contact each (S1/S2), cable gland included	106105 ZSM4200-106105

Accessories for installation in ZSM housing

- ▶ Machine stop
- ▶ Emergency stop device

Machine stop

Machine stop (black, with pull-to-reset button) for installation in housing ZSM, for different wiring concepts.

Emergency stop device

Two-channel emergency stop device (red, with pull-to-reset button) for installation in ZSM housing, for different wiring concepts.

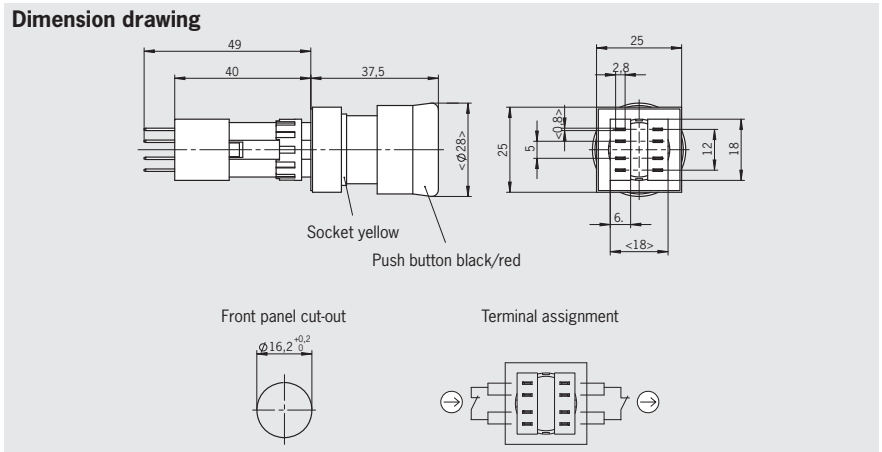

Parameter	Value
Color of actuating head	black/red
Color of bottom shell	yellow
Reset	Pull-to-reset button
Degree of protection	IP 65
Max. number of switching elements	2
Contact element	2 x positively driven contact
Utilization category acc. to IEC 947-5-1	DC-13 I _e 3 A U _e 24 V

Ordering table

Designation	Version	Order No./item
Machine stop	Installation \varnothing 16 mm, palm button black \varnothing 28 mm	106434 Machine stop 16 mm
Emergency stop device	Installation \varnothing 16 mm, palm button red \varnothing 28 mm	096298 Emergency stop 16 mm

Emergency stop device with small installation depth

Two-channel emergency stop device (red, with pull-to-reset button and turn-to-reset button) for installation in ZSM housing, for different wiring concepts.

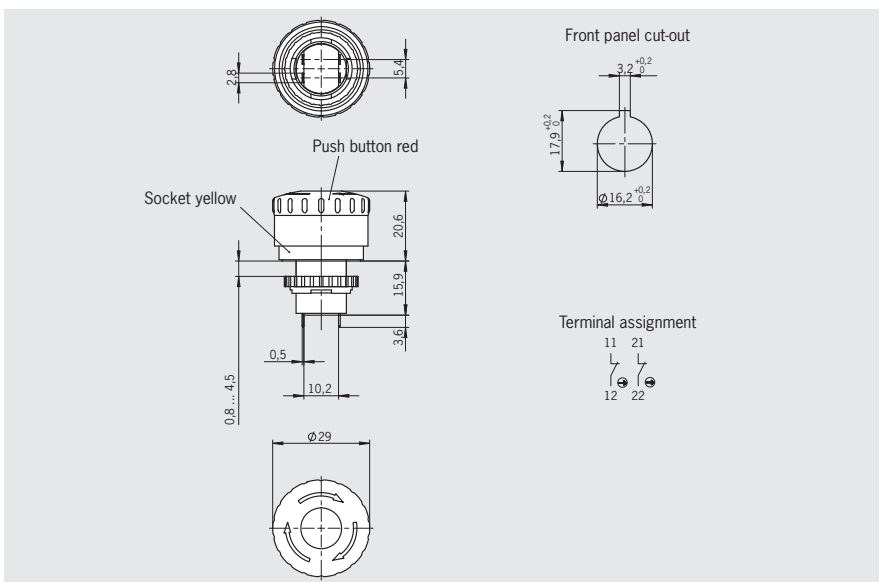

Parameter	Value
Color of actuating head	red
Color of bottom shell	yellow
Reset	Pull-to-reset button and turn-to-reset button
Degree of protection	IP 65
Number of switching elements	2
Contact element	2 x positively driven contact
Utilization category acc. to IEC 947-5-1	DC-13 I _e 3 A U _e 24 V

Ordering table

Designation	Version	Order No./item
Emergency stop device with small installation depth	Installation \varnothing 16 mm, palm button red \varnothing 29 mm	106435 ES-XA1E-BV3UU02R

- ▶ LED indicator
- ▶ Female plug RC17
- ▶ Male flange connector RC17

LED indicator

The LED indicator is used for visual feedback directly at the enabling switch.

Dimension drawing

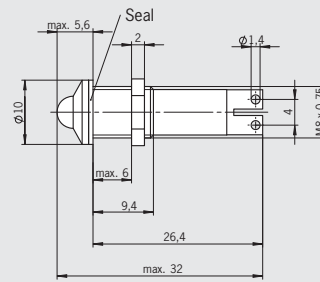

Parameter	Value
Housing	Chrome-plated
Operating voltage	24 V
Color	yellow

Ordering table

Designation	Version	Order No./item
LED indicator	Color yellow	106347 LED indicator GE 106347

Female plug RC17

Female connector for hand-held enabling switches.

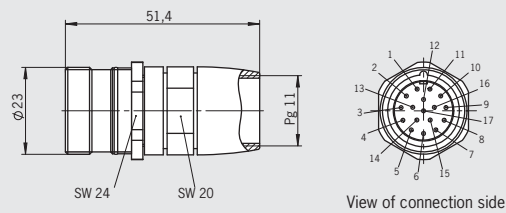

Male flange connector RC17

For connection, e.g. to enabling switches, pre-assembled.

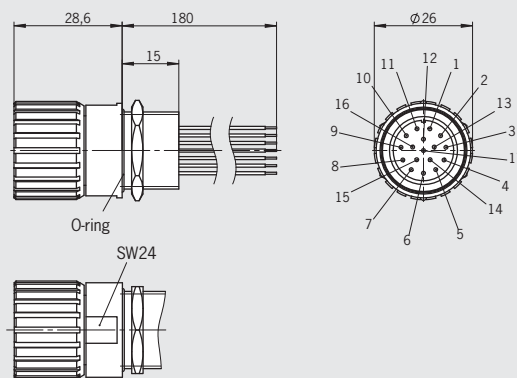

Parameter	Value
Housing material	Metal
Number of pins	12 (screen on the housing)
Cable diameter max.	Male plug 10 mm
Connection	Flange connector Crimp contacts 0.14 ... 0.56 mm ² Soldered connections 1.0 mm ²
Nominal voltage max.	230 V AC/DC
Degree of protection acc. to IEC 60529 (inserted)	IP 67

Ordering table

Item	Connection	Version	Order No./item
RC17 17-pin	Crimp contact	Female connector	106349 Female connector 17-pin
		Male flange connector with wires, pre-assembled	106360 Male flange connector 17-pin

- ▶ Pushbutton
- ▶ Key-operated switch

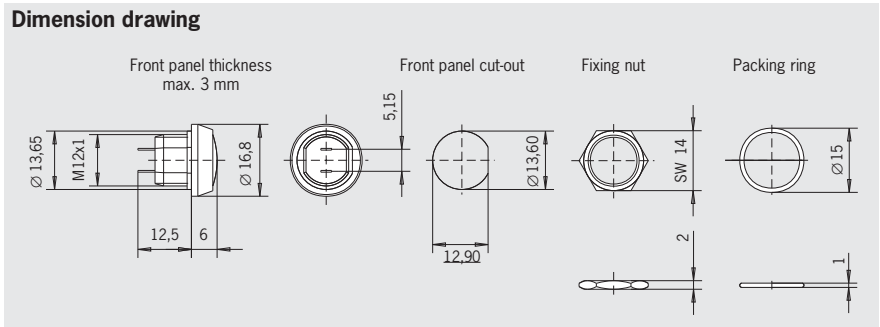

Parameter	Value
Ambient temperature	-25 ... +70 °C
Front degree of protection (integrated in front plate)	IP 67
Switching principle	Button, snap-action switching element
Switching elements	1 NO contacts
Switching voltage	DC 30 V
Switching current max.	100 mA
Connection	Soldered connection

Ordering table

Designation	Button color	Order No.
Pushbutton	Black	083640
	red	086753
	green	086754
	blue	086757
	white	086755
	yellow	086756

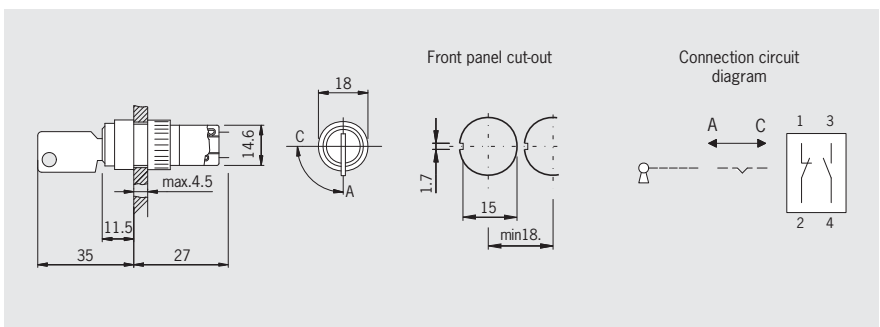

Parameter	Value
Ambient temperature	-25 ... +55 °C
Front degree of protection (integrated in front panel) / NEMA	IP 65 / 250-12
Switching principle	Snap-action switching element
Switching elements	1 NC contact, 1 NO contact
Switching voltage	AC/DC 30 V
Switching current max.	250 mA
Connection	Soldered connection

Ordering table

Designation	Version	Order No.
Key-operated switch	Key removable in both positions	083639

► Connection cable coiled and straight

View of cable cross-section

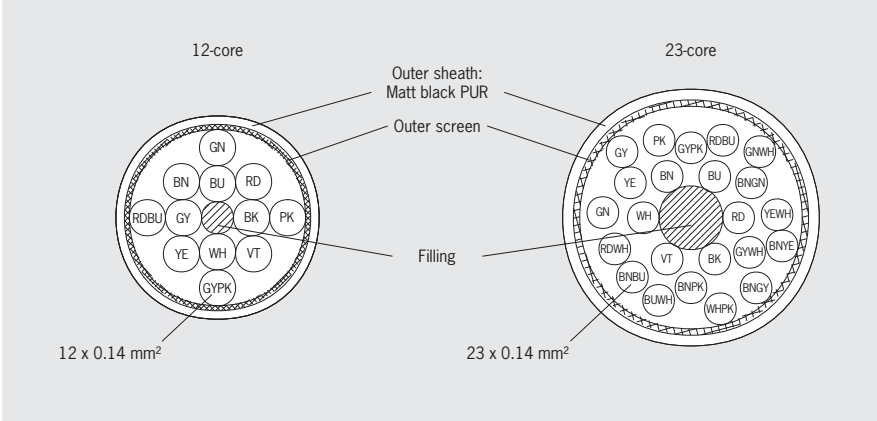

Dimensions of coiled design

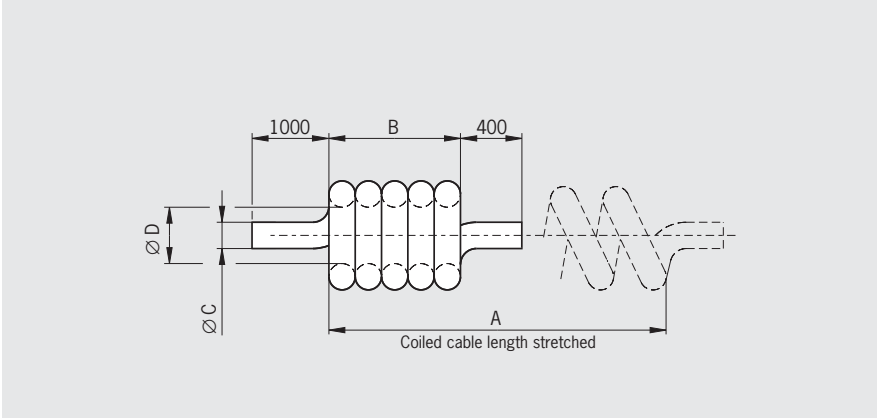

Parameter	Value
Cable resistance	≤ 145 Ω/km
Test voltage core/core	1.0 kV _{rms}
Test voltage core / screen	1.0 kV _{rms}
Insulation resistance	≥ 200
Operating temperature	-10 ... +70 °C
Bending radius	once ≥ 10 x cable diameter several times ≥ 15 x cable diameter

Ordering table

Item	Cable length [mm]	A [mm]	B [mm]	Ø C [mm]	Ø D [mm]	Order No.
12-core, coiled cable	3,900	approx. 2,500	550 ± 20	6 ± 3	8 ± 2	086721
12-core, coiled cable	5,400	approx. 4,000	880 ± 20	6 ± 3	8 ± 2	086722
12-core, straight cable	3,500	–	–	–	–	087379
12-core, straight cable	5,000	–	–	–	–	087380
12-core, straight cable	10,000	–	–	–	–	087381
23-core, coiled cable	3,900	approx. 2,500	550 ± 20	7.5 ± 0.3	10 ± 2	087408
23-core, coiled cable	5,400	approx. 4,000	880 ± 20	7.5 ± 0.3	10 ± 2	087409
23-core, straight cable	3,500	–	–	–	–	087382
23-core, straight cable	5,000	–	–	–	–	087383
23-core, straight cable	10,000	–	–	–	–	087384



Enabling switch kit ZSA and ZSA with built-in plug connector

- ▶ Housing G1
- ▶ 3-stage function
- ▶ Single or dual-channel version
- ▶ Kit without connection cable



3-stage function

Enabling function is only active in the second stage (middle position, actuating point). If the button is released or pushed further (panic function), the enabling is removed (dependent on the wiring, see function sequence).

Switching elements (see also page 8)

- ▶ **111** 1 NO + 1 NC ⊕ + 1 NC
- ▶ **121** 1 NO + 2 NC ⊕ + 1 NC
- ▶ **210** 2 NO + 1 NC ⊕
- ▶ **220** 2 NO + 2 NC ⊕
- ▶ **220** 2 NO/NC ⊕²⁾

ZSA, 3-stage function Tab connector

Dimension drawings

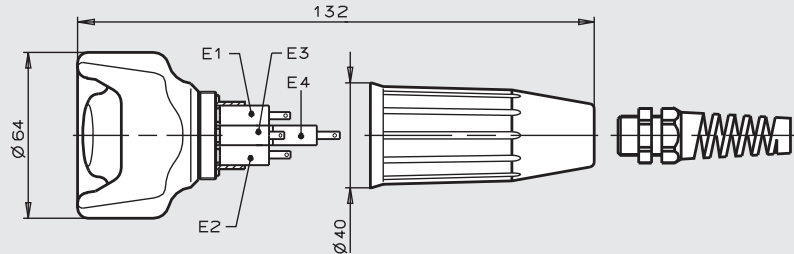

Wiring diagrams/function sequence

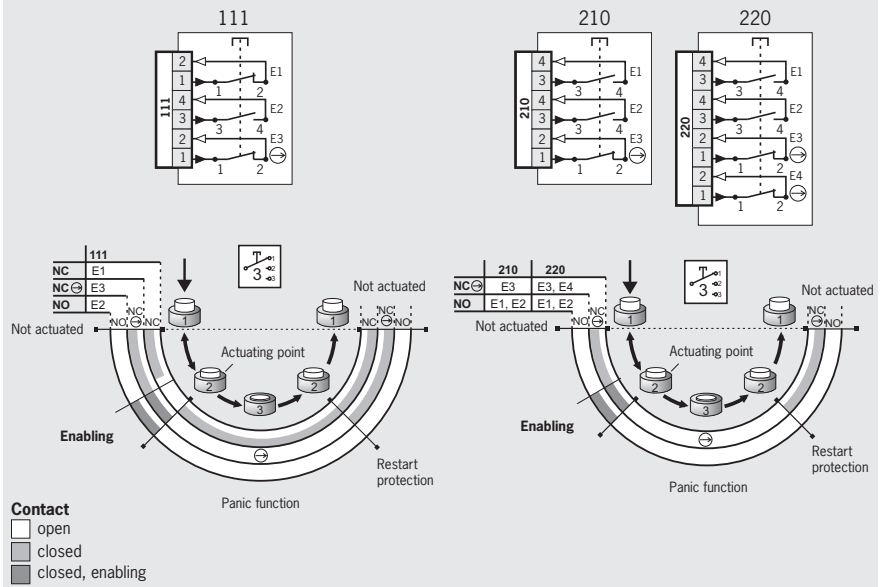

Ordering table

Design	Connection	Version	Switching element		
			111: 1 NO+1 NC ⊕ + 1 NC	210: 2 NO+1 NC ⊕	220: 2 NO + 2 NC ⊕
Kit 3-stage G1	Tab connector	without cable	070734 ZSA2-1	070735 ZSA2-2	070792 ZSA2-4

Enabling device kit ZSA

- ▶ Housing G1
- ▶ 2-stage function
- ▶ Single or dual-channel version
- ▶ Kit without connection cable



2-stage function ¹⁾

Enabling function is active in the second stage (pressed position). When the button is released, the enabling is removed (see function sequence).

Switching elements (see also page 8)

- ▶ **10** 1 NO
- ▶ **20** 2 NO
- ▶ **21** 2 NO + 1 NC

ZSA, 2-stage function ¹⁾

Tab connector

Dimension drawings

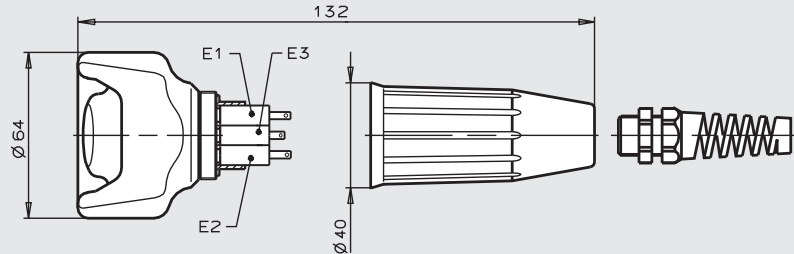

Wiring diagrams/function sequence

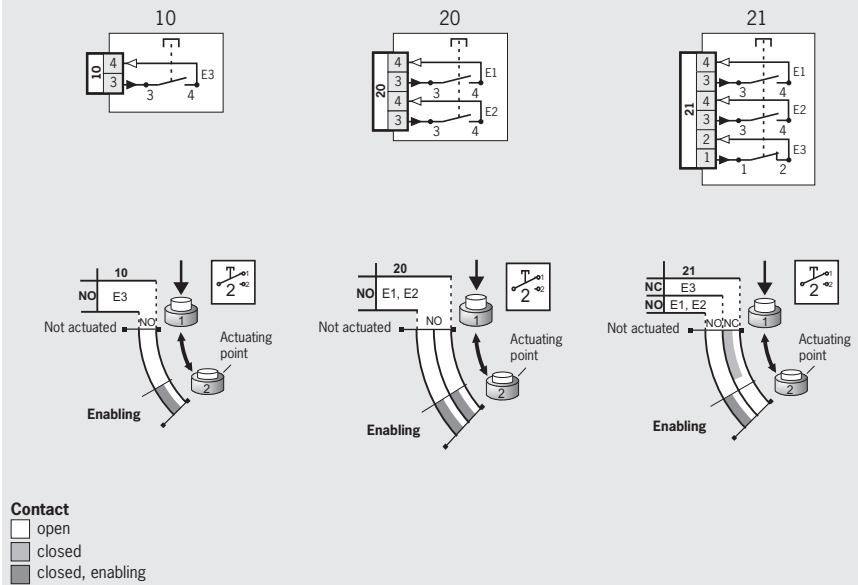

Ordering table

Design	Connection	Version	Switching element		
			10: 1NO	20: 2NO	21: 2NO+1NC
Kit 2-stage ¹⁾ G1	Tab connector	without cable	070750 ZSA1-1	070800 ZSA1-2	070736 ZSA1-3

1) As per VDI 2854, a device comparable to an emergency stop device must be fitted!

2) Only closed in middle position, a normally open contact and a positively driven contact are combined internally.

Selection table for accessories

Holders for hand-held enabling switches

Actuator for safety switches NZ.VZ and TZ with separate safety function

Plug connectors

BD4	3-pin + PE
SS4	3-pin + PE
C16-1	6-pin + PE
SD12	11-pin + PE
BS12	11-pin + PE
RC12	12-pin
RC17	17-pin
UT23	23-pin

Connection cables

Holder		Actuator	Plug connectors								Connection cables	Page
ZSM	ZSA		BD4	SS4	C16-1	SD12	BS12	RC12	RC17	UT23		
●												62
	●	●										63
			●	●	●	●	●					64
								●	●			65
										●		66
											●	68

Holder for hand-held enabling switch ZSM

- ▶ Holder for hand-held enabling switch ZSM

Screw holder for enabling switch ZSM

Depending on the version, the holder can be fastened to machine parts either with a magnet or two screws.

Screw holder for enabling switch ZSM

Dimension drawing

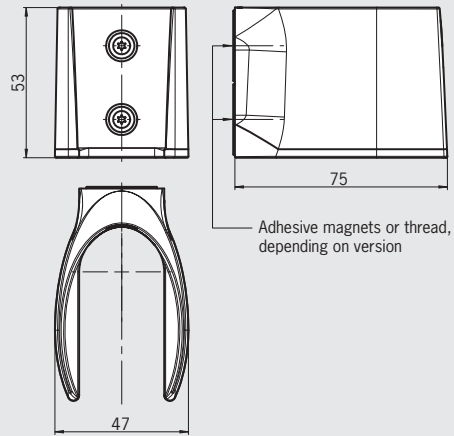

Ordering table

Designation	Version	Order No./item
Holder for enabling switch ZSM	Screw mounting	102969 Holder ZSM
	Magnet fastening	102965 Holder ZSM with magnet

Holder for hand-held enabling switches ZSA and ZSB/ Actuator for safety switches NZ.VZ and TZ with separate safety function

- ▶ Magnetic holder
- ▶ Screw holder
- ▶ Screw holder with cable hook
- ▶ Actuator for mounting on the hand-held enabling switch

Magnetic holder for housing G1

The enabling switches can be attached at any time to any part of the machine due to the magnets fastened to the holder. In this way the enabling switch can be positioned in the activity area as necessary.

Screw holder for housing G1

The holder can be securely fastened to parts of the machine with a wall thickness of max. 15 mm using two screws.

Screw holder for housing G1 with cable hook

A holder with an additional cable hook for hanging a wound-up cable.

Actuator for safety switch

Suitable for fitting, e.g. to the hand-held enabling switch kit. Safe position sampling of the enabling switch can be achieved by fitting the actuator and the use of an appropriate safety switch (NZ.VZ or TZ). By suitable integration of this combination, the signal from the safety switch can be used, e.g., as an operating mode selector switch when the actuator is removed (removal of the enabling switch). Suitable for the kit ZSA.

Magnetic holder

Dimension drawings

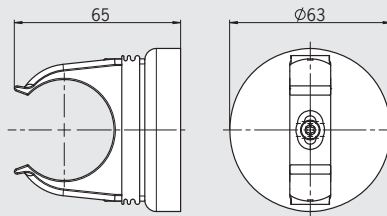

Screw holder

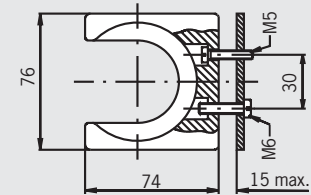

Screw holder with cable hook

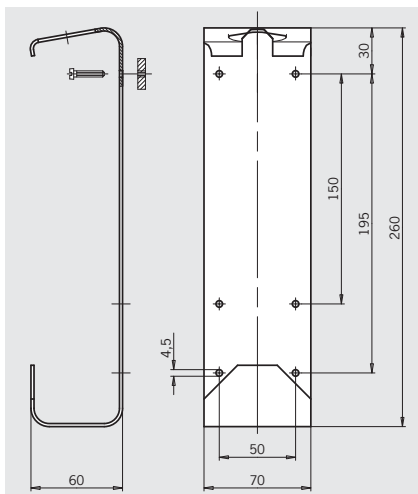

Actuator for safety switches series NZ.VZ and TZ

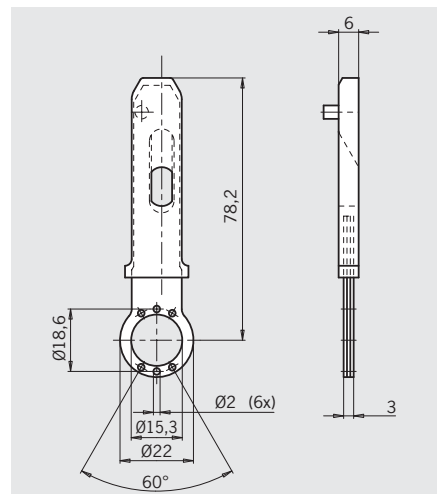

Ordering table

Designation	Version	Order No./item
Magnetic holder		059340 Magnetic holder
Screw holder	M5 x 25	052406 Holder complete
	with cable hook M4 x 20	047820 Cable holder
Actuators NZ/TZ		084833 Actuator-Z-G-C1932

Plug connectors

- ▶ Female flange connector BD4
- ▶ Male plug SS4
- ▶ Female connector C16-1
- ▶ Male flange connector SD12
- ▶ Female connector BS12
- ▶ Extension cable

Female flange connector BD4

Female flange connector for male plug SS4 on the enabling switch.

Male plug SS4

Male plug for enabling switch for connection to safety switch TZ...C1662 (see catalog NZ/TZ).

Female connector C16-1¹⁾

Female connector for hand-held enabling switches.

Male flange connector SD12

Male socket for female connector BS12. For the connection of hand-held and HBE enabling switches.

Female connector BS12

Female connector for male flange connector SD12. For connection, e.g. to enabling switch.

Female flange connector BD4 3-pin + PE

Dimension drawings

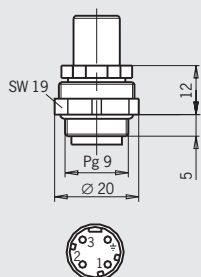

View of connection side, socket

Male plug SS4 3-pin + PE

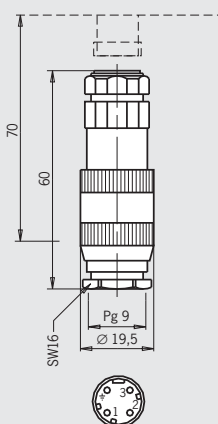

View of connection side, plug

Female connector C16-1 6-pin + PE

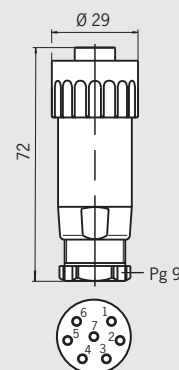

View of connection side, socket

Male flange connector SD12 11-pin + PE

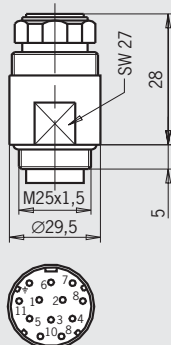

View of connection side, socket

Female connector BS12 11-pin + PE

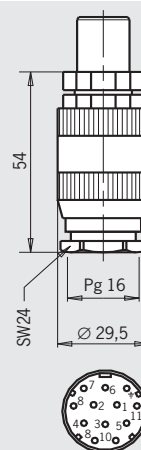

View of connection side, socket

Ordering table

Designation	Connection	Version	Order No./item
BD4 3-pin + PE	Soldered contact	Female flange connector for male plug SS4 on the enabling switch	002786 BD4
SS4 3-pin + PE	Soldered contact	Male plug for flange connector BD4 (e.g. TZ...C1662)	002787 SS4
C16-1 6-pin + PE	Crimp contact ¹⁾	Female connector	043861 Cable socket 6+PE
SD12 11-pin + PE	Soldered contact	Male flange connector for female connector BS12 on the enabling switch	085648 SD12-M
BS12 11-pin + PE	Soldered contact	Female connector, straight, for flange connector SD12	002763 BS12
BS12 11-pin + PE	-	Extension cable 5 m	071362 BS12

For information on crimp contacts see page 68.

1) Crimp contacts are included.

Plug connectors

- ▶ Female flange connector RC12
- ▶ Male plug RC12
- ▶ Blanking plug RC12
- ▶ Female flange connector RC17
- ▶ Male plug RC17
- ▶ Blanking plug RC17

Female flange connector RC12¹⁾
For front panel mounting for connection of hand-held enabling switches. Fitted with soldered contacts. Rubber seal included.

Male plug RC12¹⁾
For connection, e.g. to enabling switches.

Blanking plug RC12¹⁾
For covering the flange connector RC12. As an option, bridges can be fitted to the individual contacts at the customer, or a pre-wired version (coded) used.

Coding: bridge from pin 1 to pin 2 and from pin 9 to pin 10.

Flange connector RC17¹⁾
For front panel mounting for connection of enabling switches. Rubber seal included. Fitted with soldered contacts.

Male plug RC17¹⁾
For connection, e.g. to enabling switch.

Blanking plug RC17¹⁾
For covering the flange connector RC17. Optionally, individual contacts can be bridged at the customer.

Female flange connector RC12
12-pin

Dimension drawings

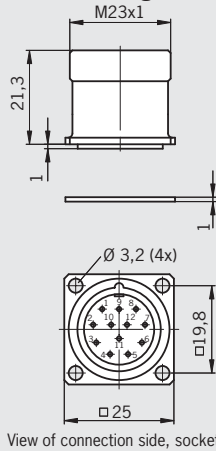

Male plug RC12
12-pin

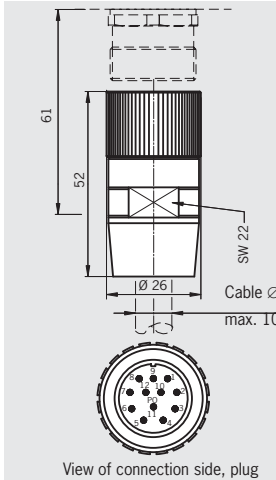

Blanking plug RC12
12-pin

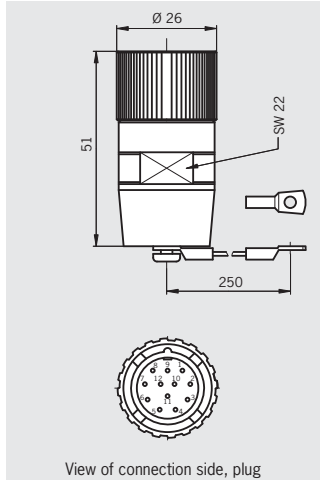

Female flange connector RC17
17-pin

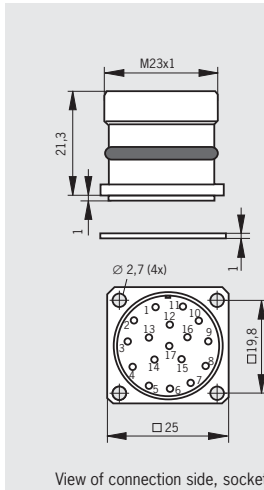

Male plug RC17
17-pin

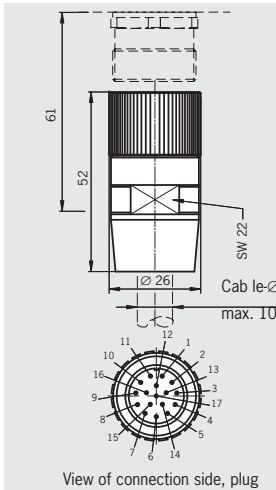

Blanking plug RC17
17-pin

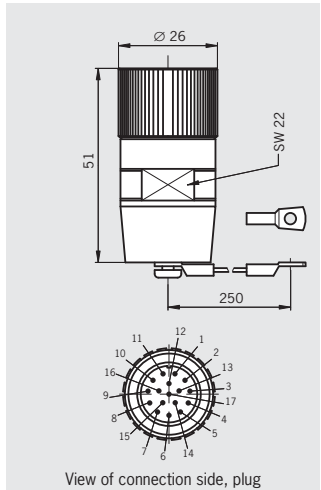

Ordering table

Designation	Connection	Version	Order No./item
RC12 12-pin	Soldered connection	Female flange connector	073290 Female flange connector 12-pin
	Crimp contact ¹⁾	Male plug	073294 Plug connector 12-pin
	Crimp contact ¹⁾	Blanking plug (with bridges) e.g. in combination with ZS...C1770	073291 Blanking plug complete 12-pin
	Crimp contact ¹⁾	Blanking plug (without bridges)	073293 Blanking plug 12-pin
RC17 17-pin	Soldered connection	Female flange connector	077502 Female flange connector 17-pin
	Crimp contact ¹⁾	Male plug	096481 Plug connector 17-pin
	Crimp contact ¹⁾	Blanking plug (without bridges)	096159 Blanking plug 17-pin

For information on crimp contacts see page 68.

1) Crimp contacts are included.

Plug connectors

- ▶ Female flange connector UT23
- ▶ Blanking plug UT23 with chain

Female flange connector UT23 ¹⁾

Female flange connector for male plug UT23 on enabling switch ...C1715.

Blanking plug UT23 with chain ¹⁾

Blanking plug for female flange connector UT23.

Female flange connector UT23
23-pin

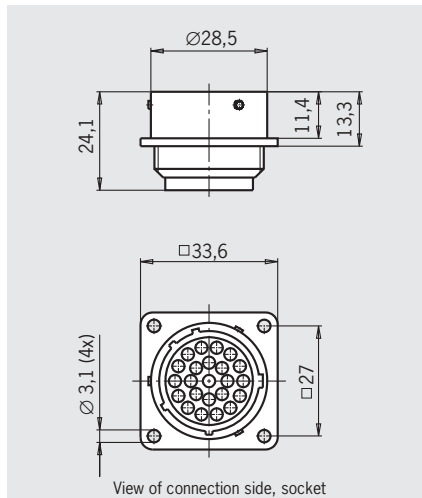

Blanking plug UT23
with chain

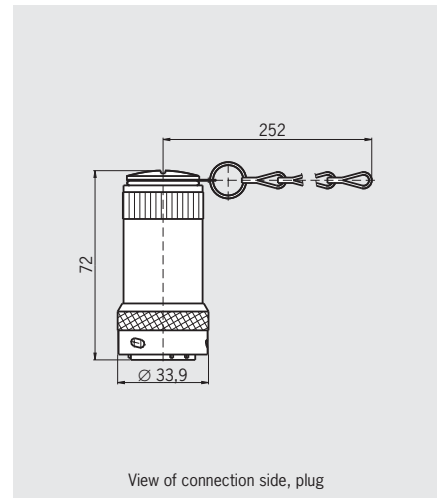

Ordering table

Designation	Connection	Version	Order No./item
UT23 23-pin	Crimp contact ¹⁾	Female flange connector for enabling switch ..C1725	074384 Flange connector / 23-pin / metal version
		Blanking plug with chain (3 bridges included)	083457 Short-circuit plug with chain

For information on crimp contacts see page 68.

1) Crimp contacts are included.

Connection cables

Connection cable for enabling switch ZSM with plug connector RC17

Connection cable for enabling switch ZSM with plug connector RC17

The high-quality connection cable for the ZSM2300-106374 is available in two lengths and can be plugged directly on the device.

The corresponding flange connector is available for connection to the ZSM kit (see page 65).

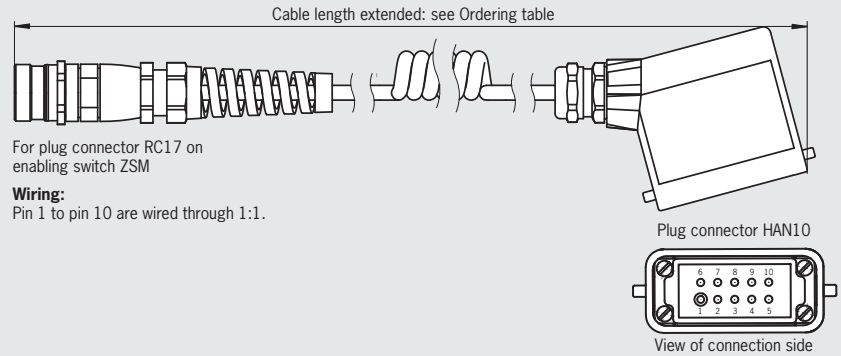

Ordering table

Designation	Version	Order No./item
Connection cable for enabling switch ZSM with plug connector RC17	Coiled, length 3.9 m	106391 Coiled cable with plug connector 3.9 m
	Coiled, length 9.0 m	106392 Coiled cable with plug connector 9 m

Connection cable for enabling switch ZXE-111276

4-pin, tab connector

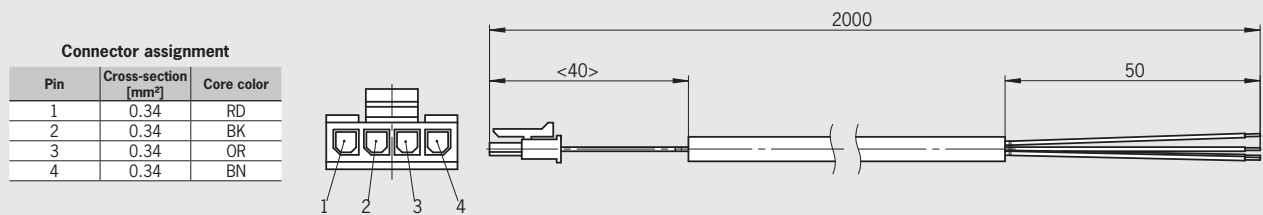

Ordering table

Designation	Connection	Order No./item
Connection cable for enabling switch ZXE-111276	Tab connector	115123 Connection cable for enabling switch ZXE-111276

List of plug connector suppliers

We provide no guarantee for the completeness and correctness of the ordering data given. The data was valid on October 2004. The related manufacturers reserve the right to make changes without notice. The plug connectors and accessories listed are also available from other manufacturers.

► Plug connectors and accessories

For plug connector	Function	Manufacturer's designation	
SVM5 5 pins	Female connector M12	99-0436-57-05 Cable socket	Binder www.binderconnector.de
	Female flange connector M12	09-3442-700-05 Flange connector with flexible wires	
	Blanking plug M12	08-2425-000-000 Protective cap for socket with retaining strap	
C16-1 6 pins + PE	Female flange connector	T3107 500 Female receptacle	Amphenol-Tuchel www.amphenol-tuchel.com
	Socket crimp contacts for C16-1, packaging unit 100 pcs.	VN02 016 0002 (1) Single contact, silver, 0.5-1.5 mm2	
	Blanking plug	T6483 000 Protective cap for female receptacle	
MR 7, 8, 9, 10 and 12 pins	Straight female connector (7-pin), pre-assembled for built-in connector MR7	MIN-7FPX-.. Female plugs with cable	MENCOM www.mencomcorp.com
	Straight female connector (8-pin), pre-assembled for built-in connector MR8	MIN-8FPX-.. Female plugs with cable	
	Straight female connector (9-pin), pre-assembled for built-in connector MR9	MIN-9FP-.. Female plugs with cable	
	Straight female connector (10-pin), pre-assembled for built-in connector MR10	MIN-10FP-.. Female plugs with cable	
	Straight female connector (12-pin), pre-assembled for built-in connector MR12	MIN-12FP-.. Female plugs with cable	
HAN10 10 pins + PE	Flange connector 1 cable exit	19 20 010 0251 Socket housing 1 cable exit	Harting www.harting.com
	Socket contacts (installation for flange connector)	09 20 010 3101 Socket contact insert crimp connection	
	Socket contacts for crimping	09 33 000 6220 Crimp contacts, socket, 0.5 mm2	
	Blanking plug	09 20 010 5425 Cover	
RC17-Y coded 17 pins	Female flange connector, solder For male connector RC17	RC-17S1Y122000 Flange plug connector 17-pin	Coninvers www.coninvers.com

► Crimp and extraction tools

For plug connector	Function	Manufacturer's designation	
SR6 and SR11	Crimp tool	932 507-002 XZC 0701	Hirschmann www.hirschmann.com
	Extraction tool	931 812-001 XWA 164	
C16-1	Crimp tool	TA0500 + TA0000163 + TA0002016001 Crimp pliers, jaws and contact receptacle	Amphenol-Tuchel www.amphenol-tuchel.com
	Extraction tool	FG 0300 1461 Extraction tool	
RC12 and RC17	Crimp tool	RC-Z2504 Crimp pliers for machined contacts	Coninvers www.coninvers.com
	Extraction tool	RC-Z2494 Extraction tool/insertion tool	
UT23	Crimp tool	Y16RCM Crimping tool for machined contacts	Burndy www.burndy.com
	Extraction tool	RX2025GE1 Extraction tool	

Overview

Wiring diagrams ZSM

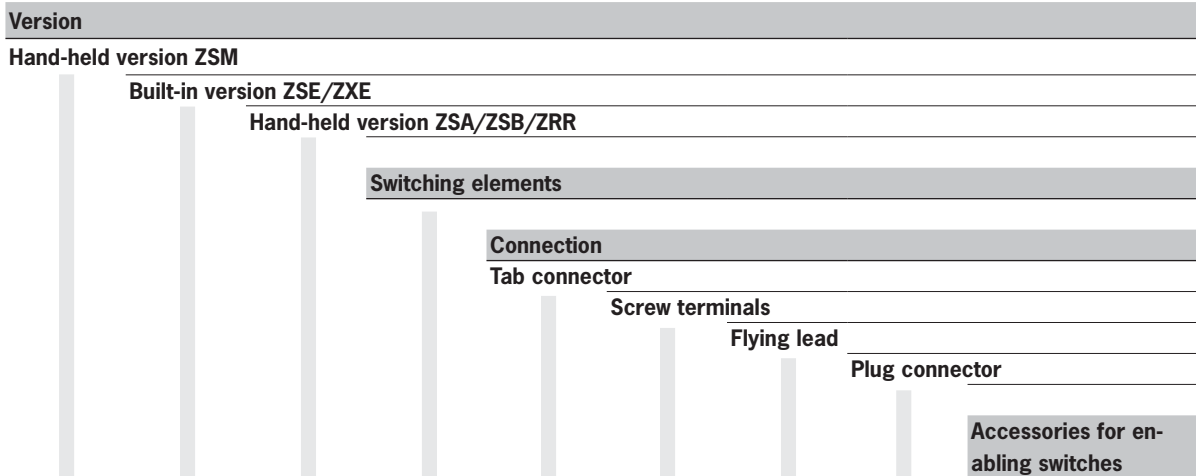

Wiring diagrams ZSM	Version			Switching elements	Connection				Accessories	Page
	ZSM Hand-held	ZSE/ZXE Built-in	ZSA/ZSB/ZSR Hand-held		Tab connec- tor	Screw termi- nals	Flying lead	Plug connec- tor		
•										70 - 76
	•									77/78
		•								79
			•							79
				•						79
					•					80
						•				80
							•			80
								•		80/82
									•	83/84

Wiring diagrams

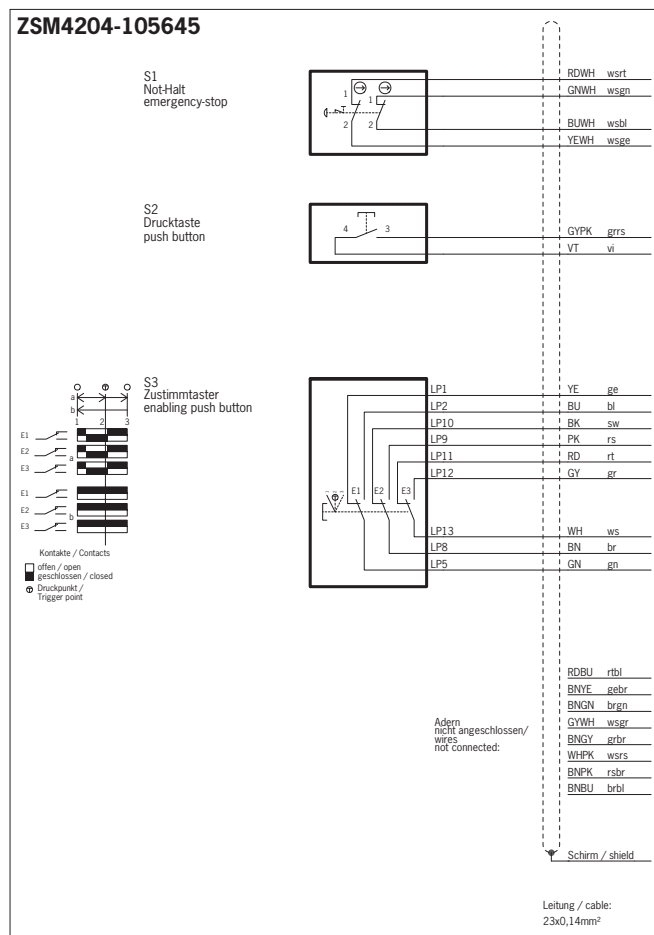
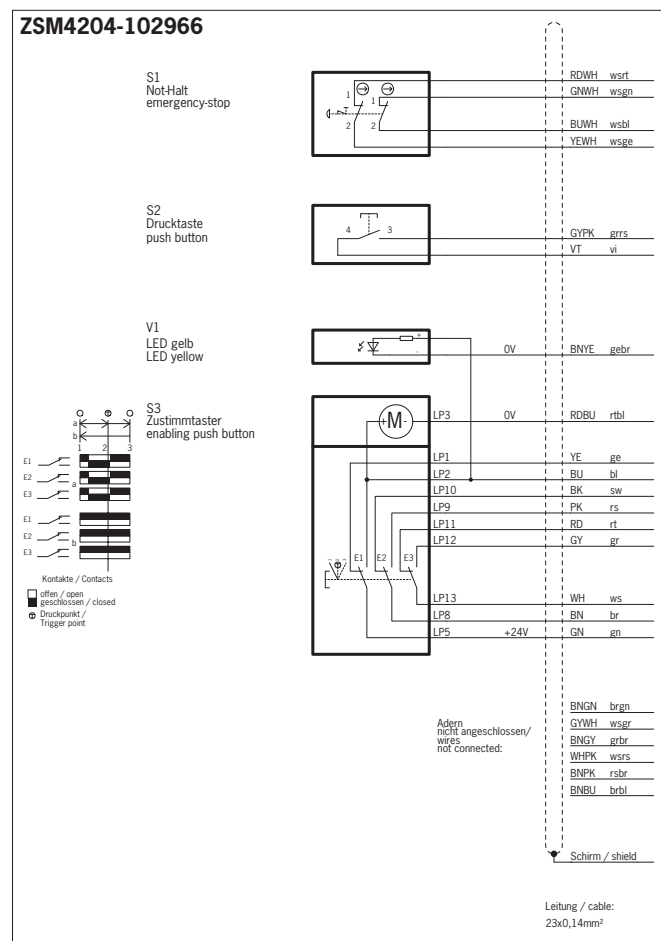
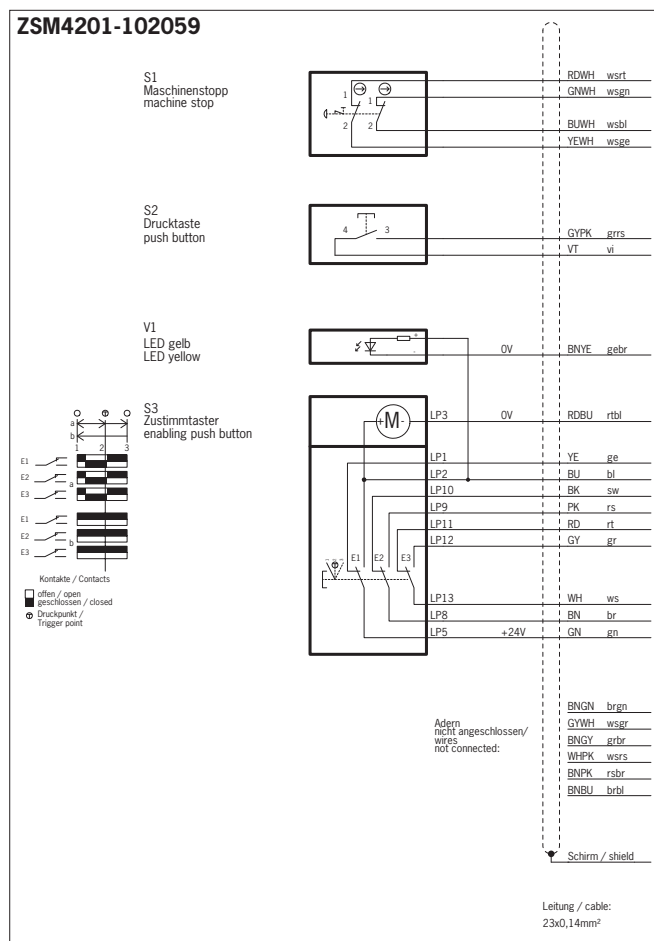

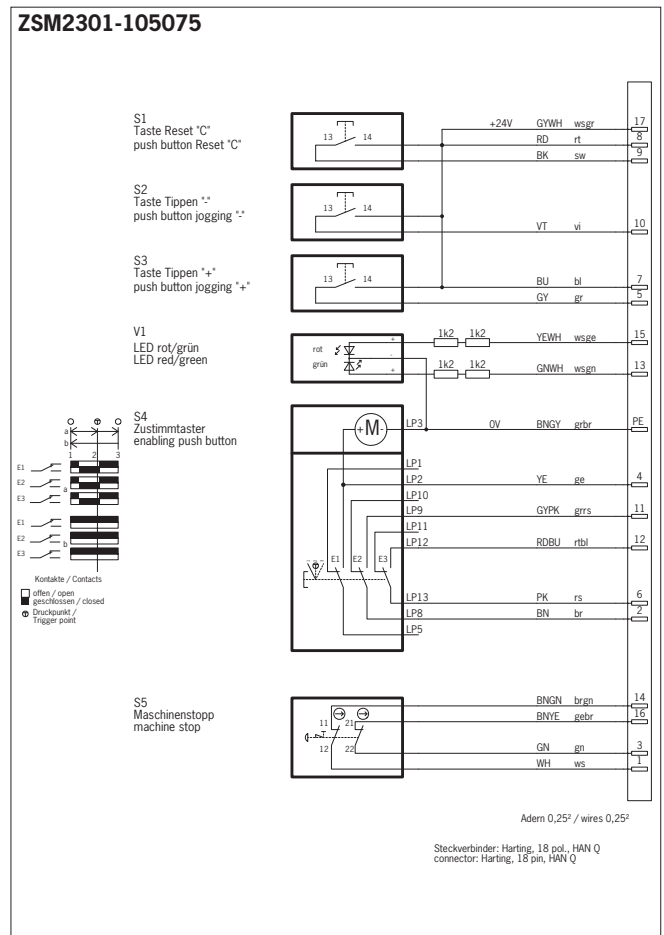
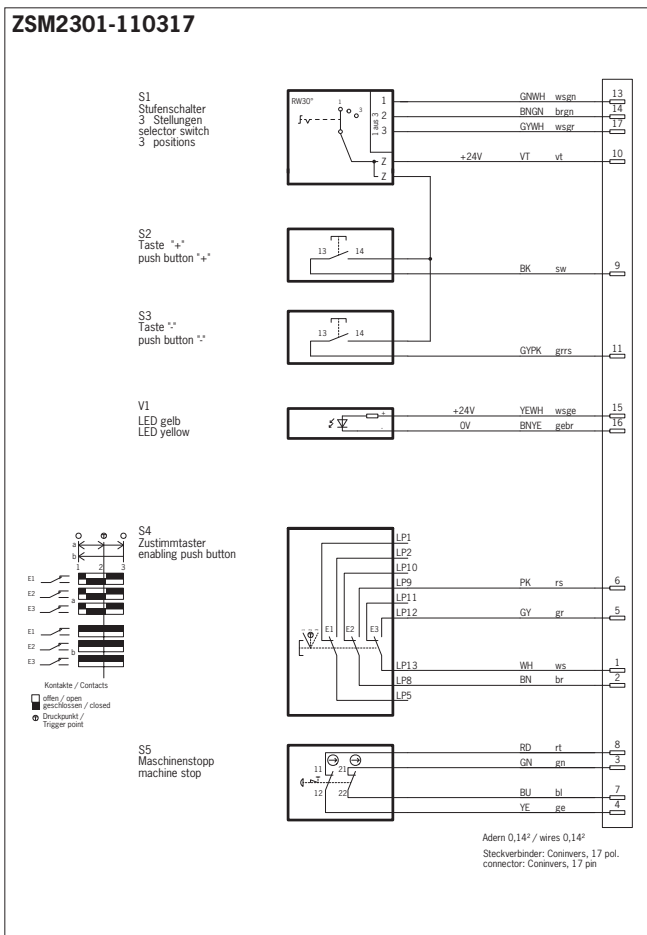
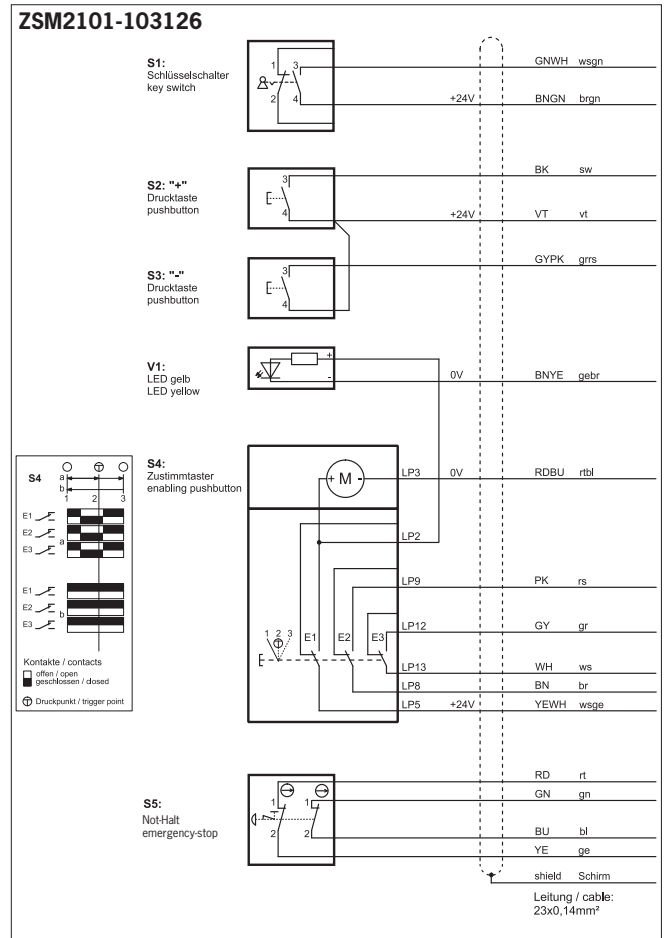
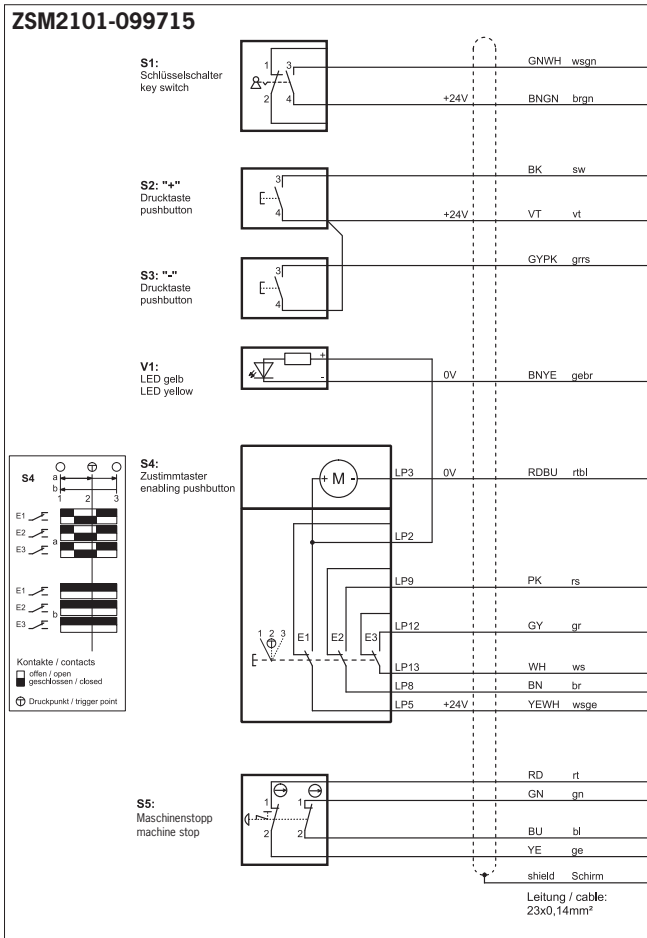

Wiring diagrams

ZSM4200-099713

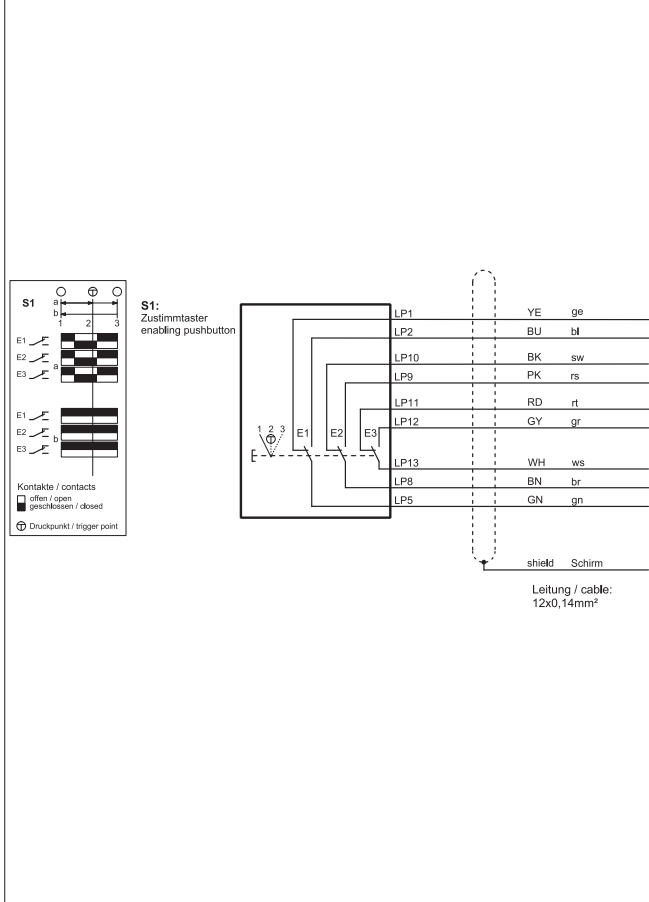

ZSM2300-111871

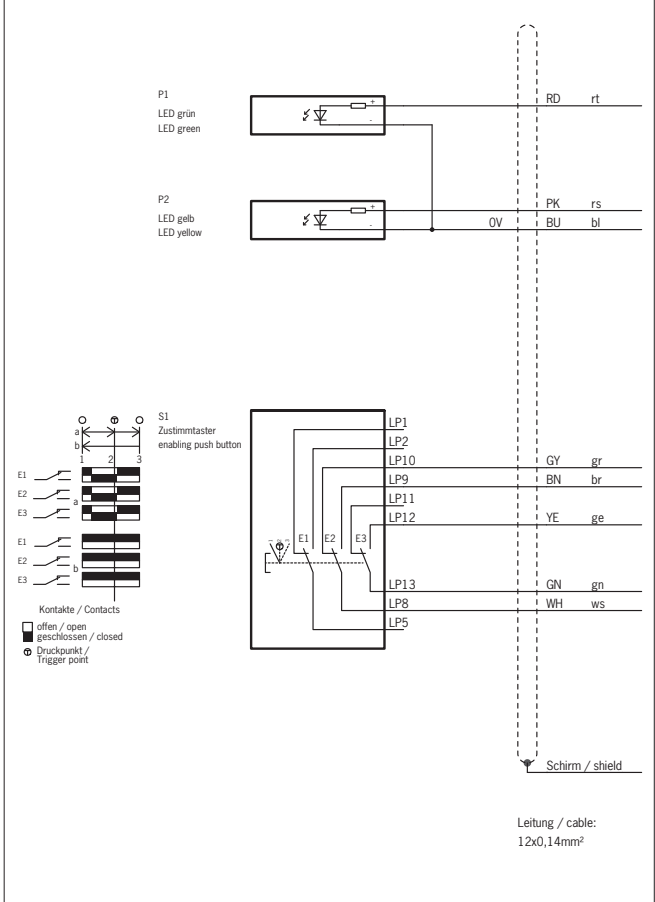

ZSM2100-099714

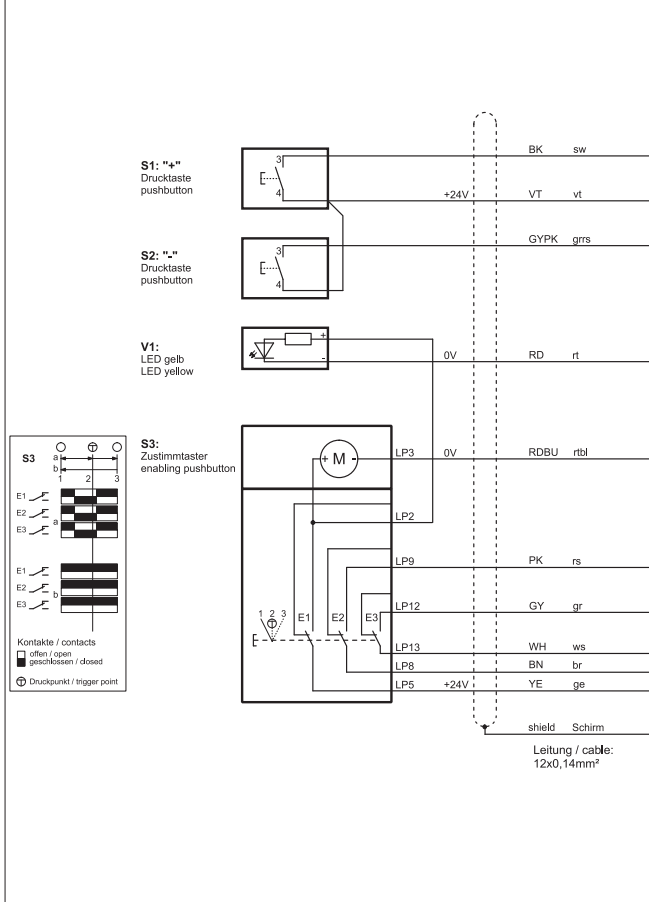

ZSM2300-109971
ZSM2300-112803

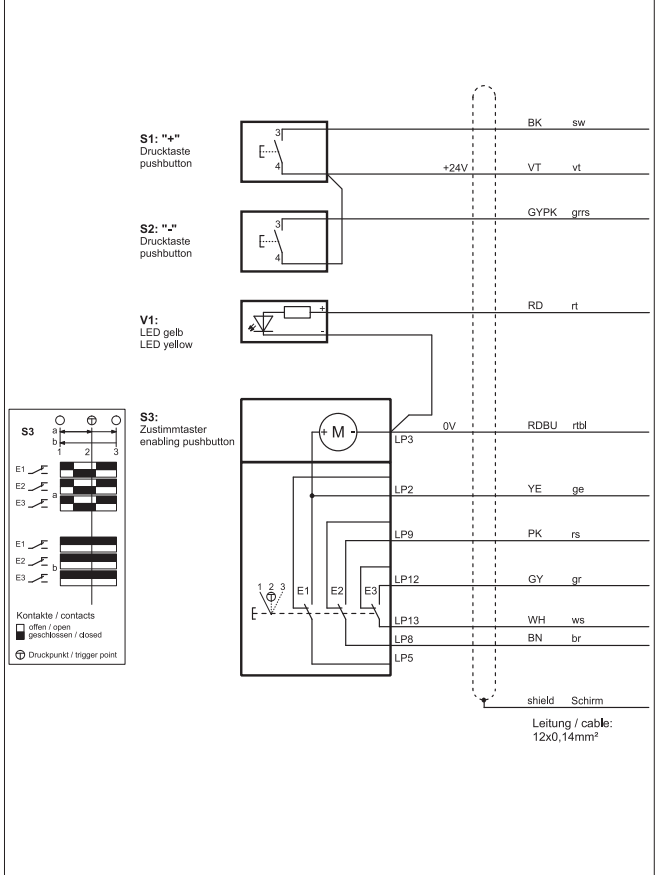

ZSM2300-111462

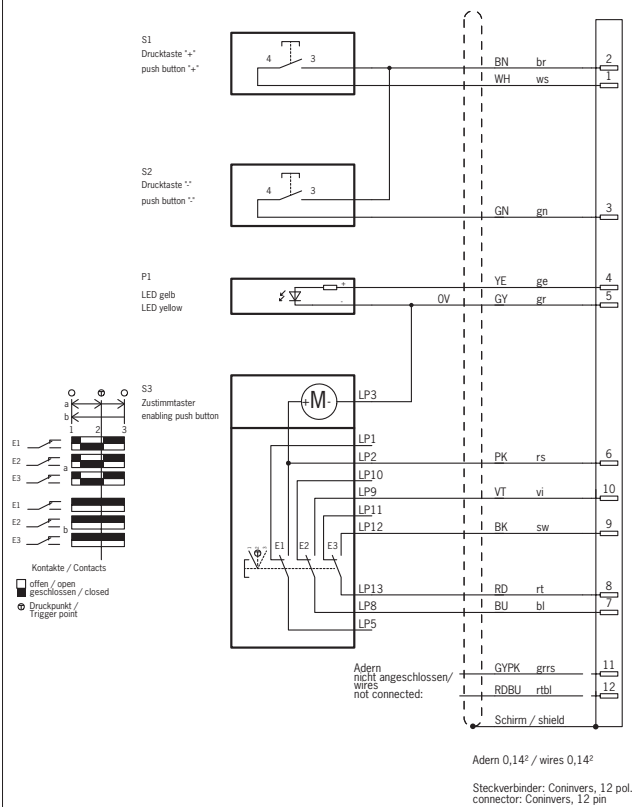

ZSM2100-111594

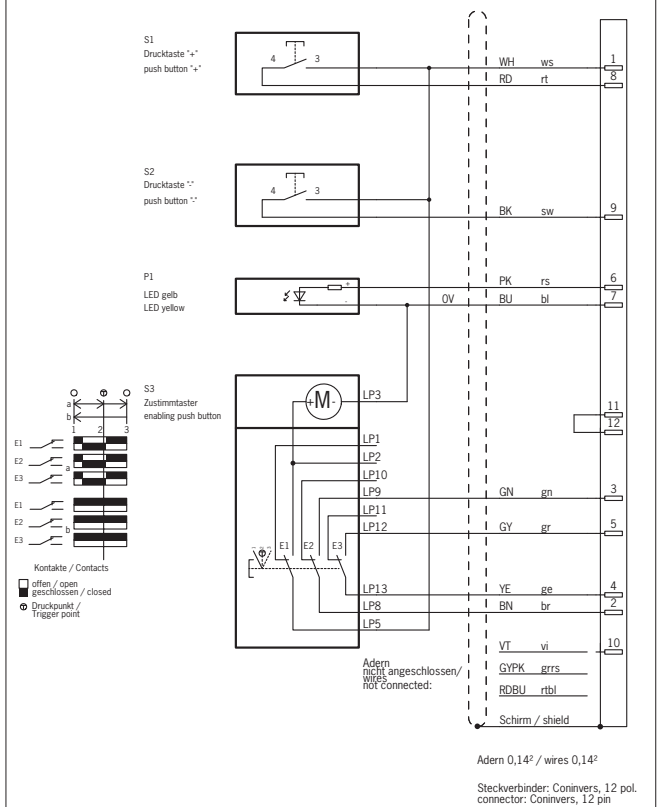

ZSM2300-099716 ZSM2300-113290

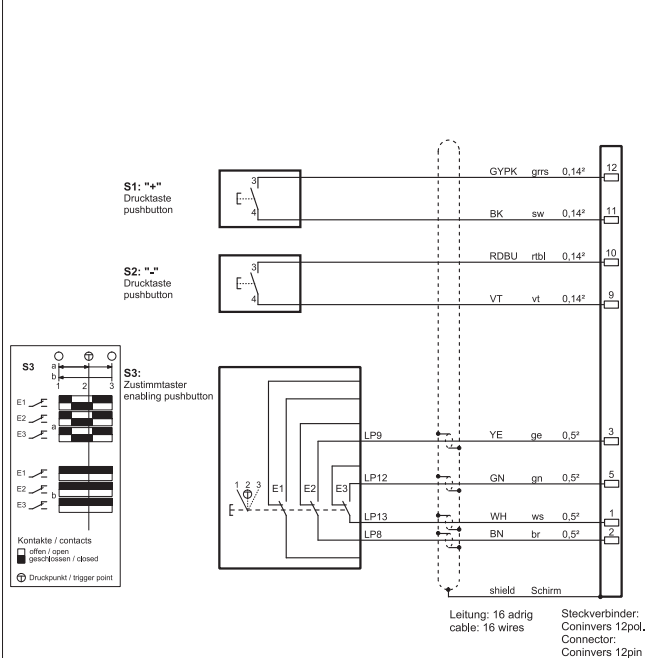

ZSM2200-100697

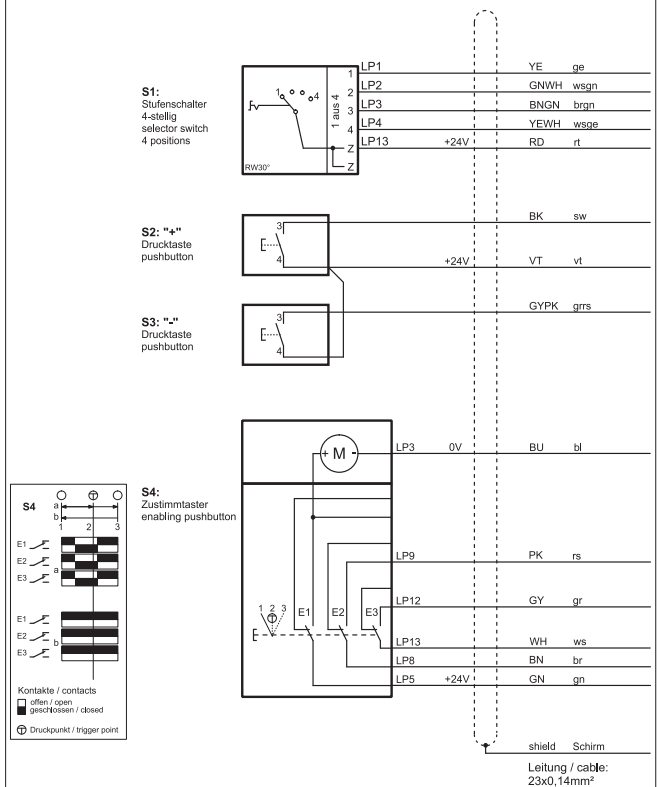

ZSM2100-106103

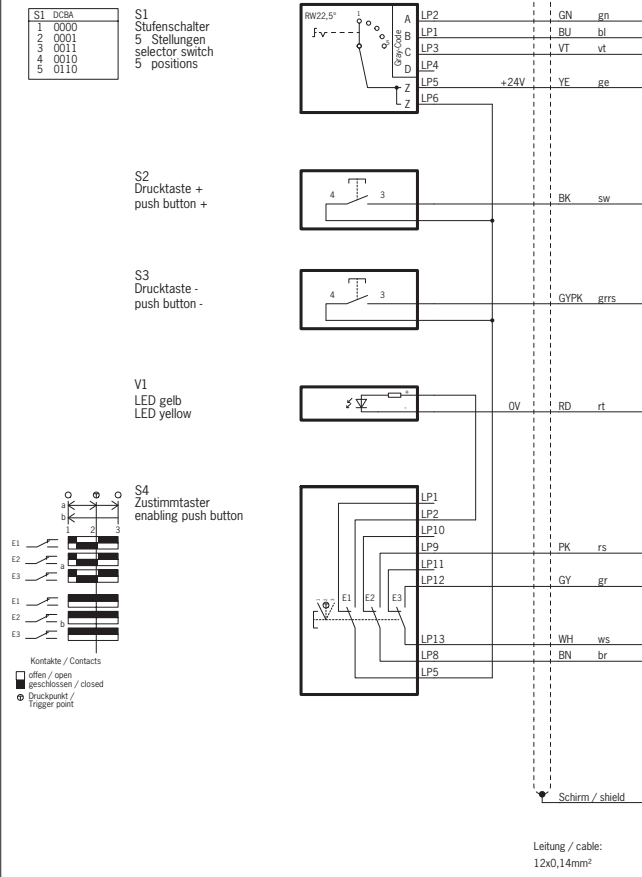

ZSM2200-105308

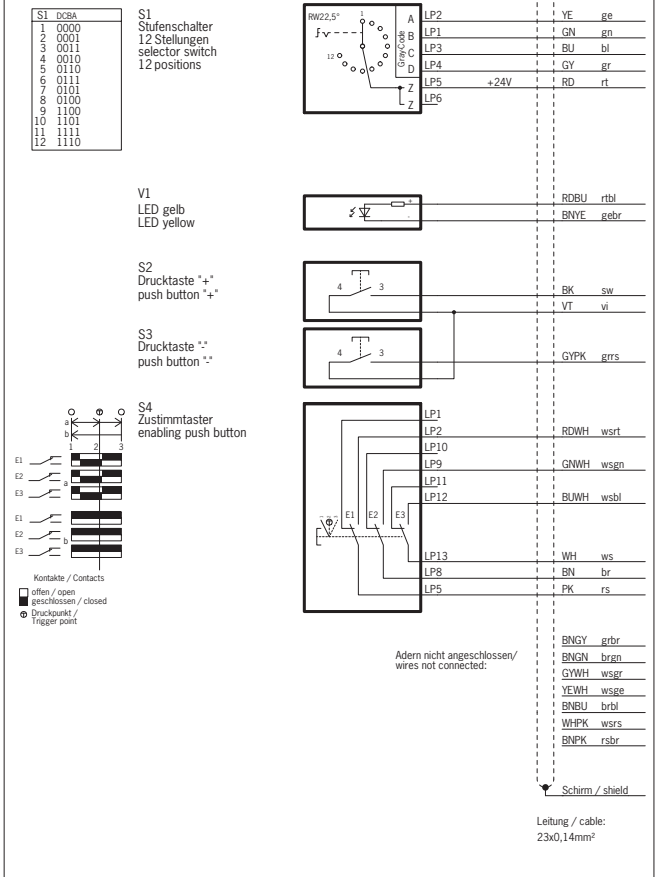

ZSM3100-103462

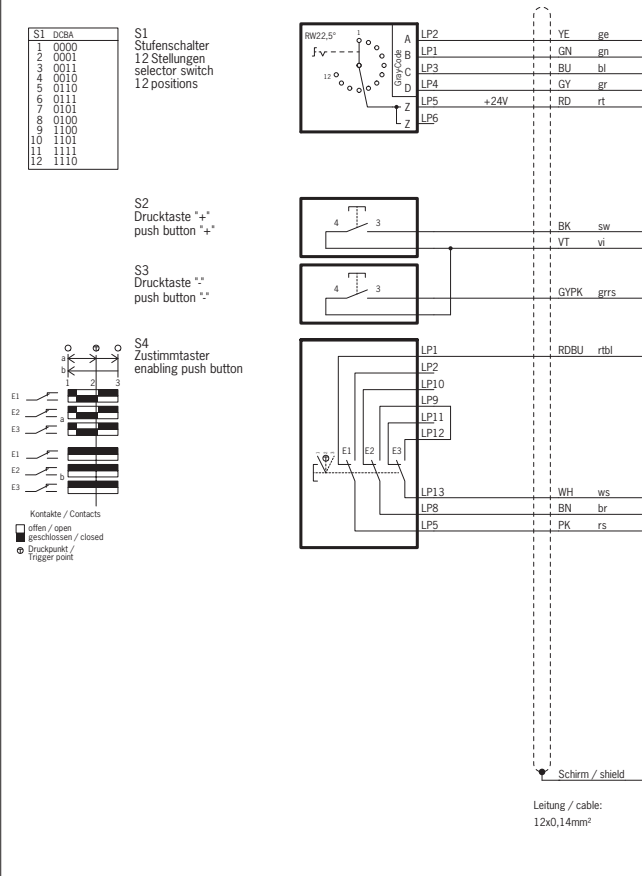

ZSM2200-112033

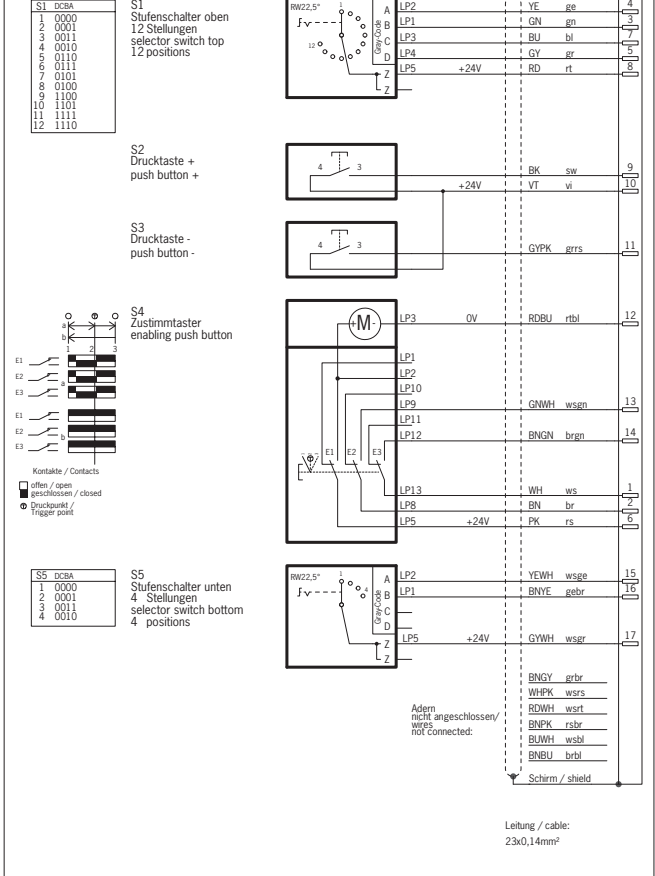

Wiring diagrams

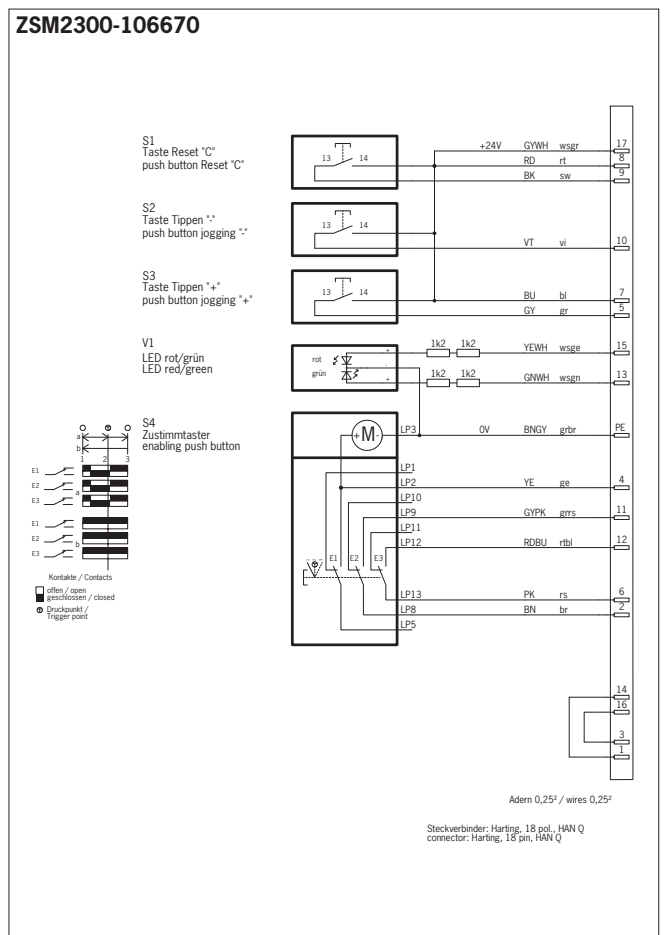
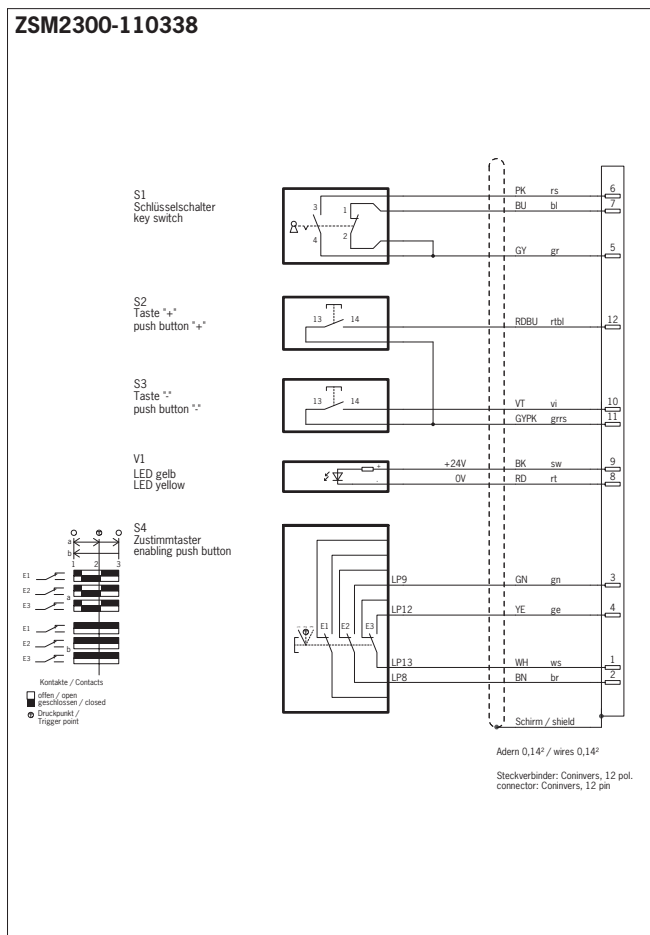
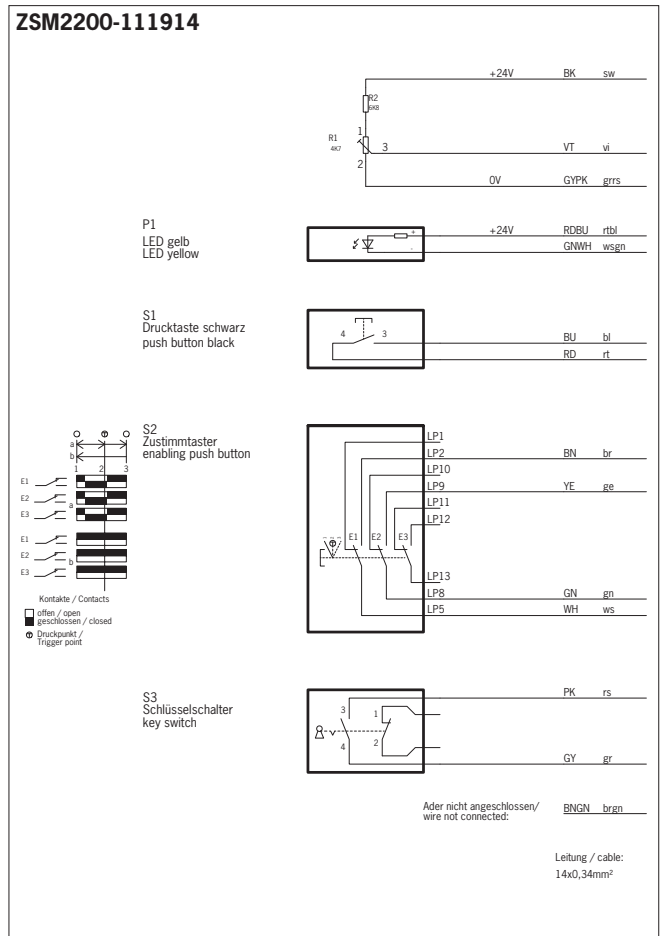
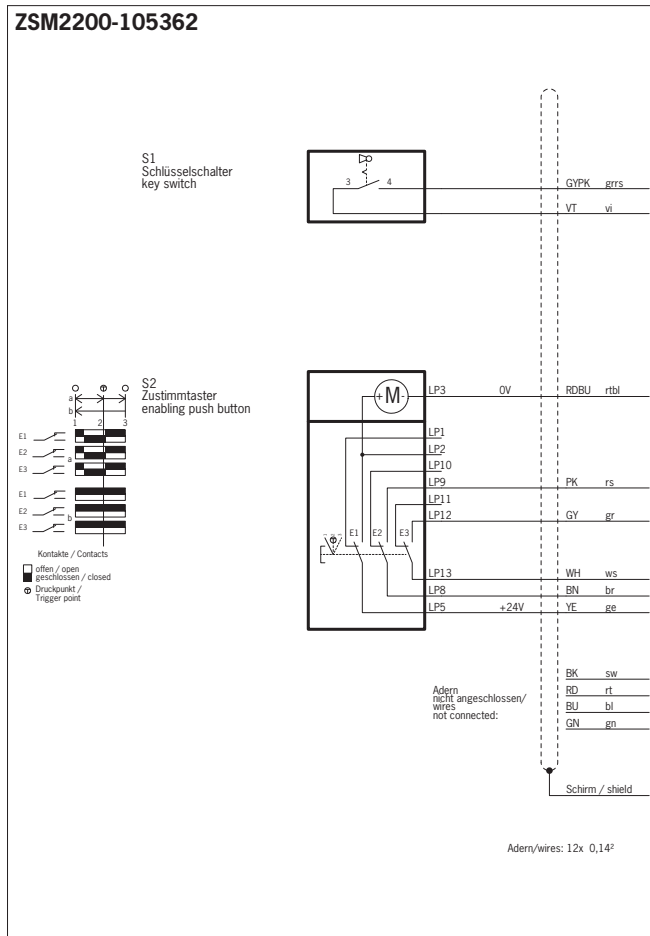

ZSM2300-106374

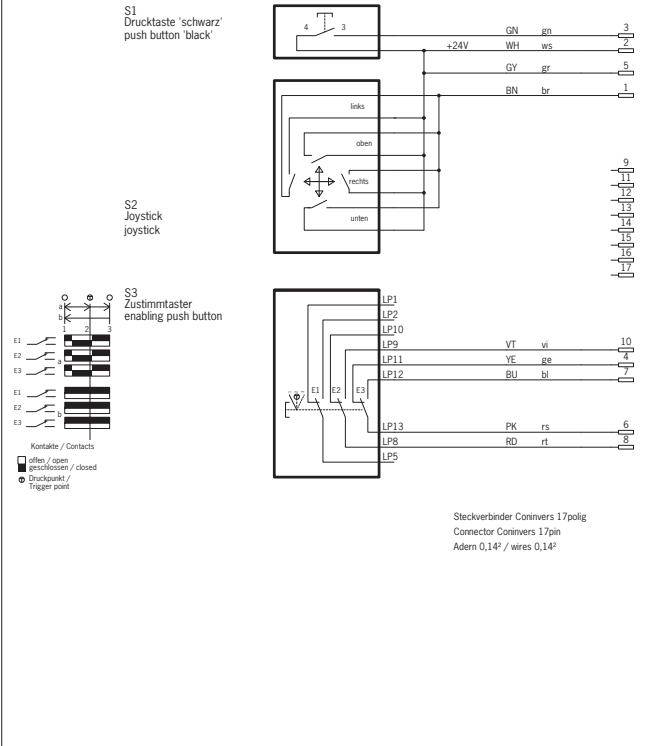

Technical data

Basic enabling switch ZSM			
Parameter		Value	Unit
Material	Housing	PA	
	Enabling switch	CR	
	Grip/seal	TPE	
Degree of protection according to IEC 529		IP 54	
Ambient temperature		-5 ... +60	°C
Weight (incl. connection cable)		approx. 1.1	kg

Switching element, enabling switch			
Parameter		Value	Unit
Switching contacts		3 changeover contacts	
Life		1 x 10 ⁶ operating cycles	
Utilization category to IEC 947-5-1 (for enabling switch)		DC13 U _e 24 V I _e 0.3 A U _e 24 V I _e 1 A	

Machine stop			
Parameter		Value	Unit
Color of actuating head		Black	
Color of bottom shell		yellow	
Reset		Pull-to-reset button	
Degree of protection		IP 65	
Max. number of switching elements		2	
Contact element		2 x positively driven contact	
Utilization category according to IEC 947-5-1		DC-13 I _e 1 A U _e 24 V	

Emergency stop device			
Parameter		Value	Unit
Color of actuating head		red	
Color of bottom shell		yellow	
Reset		Pull-to-reset button and turn-to-reset button	
Degree of protection		IP 65	
Number of switching elements		2	
Contact element		1 x positively driven contact	
Utilization category according to IEC 947-5-1		DC-13 I _e 1 A U _e 24 V	

Single-color LED indicator			
Parameter		Value	Unit
Housing		Chrome-plated	
Operating voltage		24	V
Color		yellow or red	

Two-color LED indicator			
Parameter		Value	Unit
Forward current typ.		0.02	A
Voltage red		1.85	V
Voltage green		2.2	V

Reset button/pushbutton			
Parameter		Value	Unit
Switching voltage max.		30	V DC
Switching current max.		0.1	A

Selector switch			
Parameter		Value	Unit
Output code		see wiring diagrams	
Switching voltage max.		25	V AC/DC
Breaking capacity max.		0.2	VA

Key-operated rotary switch

Parameter	Value	Unit
Switching voltage max.	30	V AC/DC
Switching current max.	0.25	A

Rotary potentiometer

Parameter	Value	Unit
Resistance value	4.7	kΩ
Ambient temperature	- 55 to + +125	°C
Actuating torque	0.5 to 3.5	Ncm

One-touch function

Parameter	Value	Unit
Max. switching current at 28 V DC	2	A
- with resistive load	1	
- with inductive load		

Connection using flying lead

Parameter	Value	Unit
Connection	Cable 12 x 0.14 mm ² Cable 23 x 0.14 mm ²	
Short circuit protection acc. to IEC 60269-1 (control circuit fuse)	2	A gG
Utilization category according to EN 60947-5-1		
Enabling switches DC-13	I _e 1 A U _e 24 V	
Keys and LEDs DC-13	I _e 0.3 A U _e 24 V	

Plug connector RC12 connection

Parameter	Value	Unit
Connection	Male connector	
Version	RC12 (11-pin + PE)	
Conductor cross-section	0.14	mm ²
Rated insulation voltage U _i	0.8	kV
Utilization category according to EN 60947-5-1		
Enabling switches DC-13	I _e 1 A U _e 24 V	
Keys and LEDs DC-13	I _e 0.3 A U _e 24 V	

Plug connector RC17 connection

Parameter	Value	Unit
Connection	Male connector	
Version	RC17 (17-pin)	
Conductor cross-section	0.14	mm ²
Rated insulation voltage U _i	0.8	kV
Utilization category according to EN 60947-5-1		
Enabling switches DC-13	I _e 1 A U _e 24 V	
Keys and LEDs DC-13	I _e 0.3 A U _e 24 V	

Plug connector HAN Q17 connection

Parameter	Value	Unit
Connection	Male connector	
Version	HAN Q17 (17-pin)	
Conductor cross-section	0.14	mm ²
Rated insulation voltage U _i	0.8	kV
Utilization category according to EN 60947-5-1		
Enabling switches DC-13	I _e 1 A U _e 24 V	
Keys and LEDs DC-13	I _e 0.3 A U _e 24 V	

Built-in version			
Parameter	Value		Unit
Housing material	Polyamide, black		
Protective cap material	CR (neoprene), black		
Degree of protection according to IEC 60529	On the front panel	IP 65	
Ambient temperature	- 5 to + +60		°C
Installation position	Any		
Weight	ZSE/ZSG: approx. 0.1	ZXE: approx. 0.03	kg
Reliability values according to EN ISO 13849-1			
B _{10d}	ZSE	5 x 10 ⁵ operating cycles	
	ZXE	1 x 10 ⁶ operating cycles	

Hand-held version G1			
Parameter	Value		Unit
Housing material	Polyamide, black		
Protective cap material	CR (neoprene), black		
Degree of protection according to IEC 60529	IP 67 / IP 65 with additional function (button, LED)		
Ambient temperature	- 5 to + 50		°C
Weight	Approx. 0.4 (no cable)		kg
Reliability values according to EN ISO 13849-1			
B _{10d}	ZSA	5 x 10 ⁵ operating cycles	
	ZSB	5 x 10 ⁵ operating cycles	

Hand-held version G2			
Parameter	Value		Unit
Housing material	Polyamide, yellow		
Protective cap material	CR (neoprene), black		
Degree of protection according to IEC 60529	IP 65		
Ambient temperature	- 5 to + 50		°C
Weight	Approx. 1.1 (with 5 m straight cable)		kg
Reliability values according to EN ISO 13849-1			
B _{10d}	ZSR	5 x 10 ⁵ operating cycles	

Hand-held version G3			
Parameter	Value		Unit
Housing material	Polyamide, yellow		
Protective cap material	CR (neoprene), black		
Degree of protection according to IEC 60529	IP 65		
Ambient temperature	- 5 to + 50		°C
Weight	Approx. 1.5 (with 5 m straight cable)		kg
Reliability values according to EN ISO 13849-1			
B _{10d}	ZSB	5 x 10 ⁵ operating cycles	

Switching elements			
Parameter	Value		Unit
Switching principle	Slow-action switching contact		
Life	1 x 10 ⁵ cycles		
Function sequence	2-stage	3-stage	
Switching element with 1 switching contact	10 1 NO	110 1 NO/NC ⊖	
Switching element with 2 switching elements	20 2 NO	1210 1 NO/NC ⊖ + 1 NO	2202 2 NO/NC
Switching element with 3 switching elements	21 2 NO + 1 NC	111 1 NO + 1 NC ⊖ + 1 NC	210 2 NO + 1 NC ⊖
Switching element with 4 switching elements	-	121 1 NO + 2 NC ⊖ + 1 NC	220 2 NO + 2 NC ⊖
Min. switching current at 24 V	1 mA (ZXE switching element 2202: 5 mA)		

Tab connector connection, hand-held kit ZSA

Parameter	Value	Unit
Connection	Tab connector	
Version according to IEC 60760	2.8 x 0.8 mm	
Degree of protection according to IEC 60529	IP 00	
Rated impulse withstand voltage U_{mp}	2.5	kV
Rated insulation voltage U_i	250	V AC/DC
Conventional thermal current I_{th}	3	A
Short circuit protection acc. to IEC 60269-1 (control circuit fuse)	4	A gG
Utilization category according to EN 60947-5-1	AC-15	I_e 4 A U_e 230 V
	DC-13	I_e 3 A U_e 24 V

Screw terminal connection, ZXE

Parameter	Value	Unit
Connection	Screw terminals	
Version	4-pin	
Tightening torque, max.,	0.15	Nm
Conductor diameter	single cond. 0.3 - 1.4 mm, AWG 22 - 16	
Conductor nominal diameter	single cond. 1.5	mm ²
	flexible cond. 1 mm ² , AWG 16	
Conductor insulation stripping	5	mm
Degree of protection according to IEC 60529	IP 00	
Rated impulse withstand voltage U_{mp}	1.5	kV
Rated insulation voltage U_i	30	V AC/DC
Conventional thermal current I_{th}	0.1	A
External fuse U (+LA) / U (+LB)	0.1	A gG
Utilization category according to EN 60947-5-1	DC-13	I_e 0.1 A U_e 24 V

Connection using flying lead

Parameter	Value	Unit
Connection	Cable 3 x 0.75 mm ² Cable 6 x 0.34 mm ² Cable 8 x 0.34 mm ² Cable 8 x 0.5 mm ² + 8 x 0.14 mm ²	
Version	Individual screening	2 x 0.75 3 x 0.34 4 x 0.34 4 x 0.5
	Without screen	1 x 0.75 3 x 0.34 4 x 0.34 4 x 0.5
	Additional elements	- - - 8 x 0.14
Rated impulse withstand voltage U_{mp}	2.5 2.5 2.5 2.5	kV
Rated insulation voltage U_i	250 250 250 250	V AC/DC
Short circuit protection acc. to IEC 60269-1 (control circuit fuse)	4 2 2 2	A gG
Utilization category of enabling switch according to EN 60947-5-1	AC-15	I_e 4 A U_e 230 V I_e 2 A U_e 230 V I_e 2 A U_e 230 V I_e 2 A U_e 230 V
	DC-13	I_e 3 A U_e 24 V I_e 2 A U_e 24 V I_e 2 A U_e 24 V I_e 2 A U_e 24 V
Utilization category of buttons and LEDs according to EN 60947-5-1	AC-15	- - I_e 400 mA U_e 32 V I_e 400 mA U_e 32 V
	DC-13	- - I_e 100 mA U_e 50 V I_e 100 mA U_e 50 V

Plug connector SS4 connection

Parameter	Value	Unit
Connection	Male connector	
Version	SS4 (3-pin + PE)	
Connection cable conductor cross-section	6 x 0.34	mm ²
Degree of protection according to IEC 60529	IP 67 ¹⁾	
Rated impulse withstand voltage U_{mp}	0.8	kV
Short circuit protection acc. to IEC 60269-1 (control circuit fuse)	2	A gG
Utilization category according to EN 60947-5-1	AC-15	I_e 2 A U_e 230 V
	DC-13	I_e 2 A U_e 24 V

Plug connector SVM5 connection

Parameter	Value	Unit
Connection	Male connector	
Version	SVM5 (5-pin)	
Connection cable conductor cross-section	6 x 0.34	mm ²
Degree of protection according to IEC 60529	IP 67 ¹⁾	
Rated impulse withstand voltage U_{mp}	0.8	kV
Short circuit protection acc. to IEC 60269-1 (control circuit fuse)	2	A gG
Utilization category according to EN 60947-5-1	AC-15	I_e 2 A U_e 24 V
	DC-13	I_e 2 A U_e 24 V

¹⁾ Only screwed tight with the related plug connector from page 64ff

Plug connector C16 connection

Parameter	Value		Unit
Connection	Male connector		
Version	C16 (6-pin + PE)		
Connection cable conductor cross-section	3 x 0.75	8 x 0.34	mm ²
Degree of protection according to IEC 60529	IP 67 ¹⁾		
Rated impulse withstand voltage U _{imp}	0.8		kV
Short circuit protection acc. to IEC 60269-1 (control circuit fuse)	2		A gG
Utilization category according to EN 60947-5-1	AC-15	I _e 2 A U _e 24 V	
	DC-13	I _e 2 A U _e 24 V	

Plug connector MR7 connection

Parameter	Value		Unit
Connection	Male connector		
Version	MR7 (7-pin)		
Connection cable conductor cross-section	without cable		mm ²
Degree of protection according to IEC 60529	IP 65 ¹⁾		
Rated impulse withstand voltage U _{imp}	0.8		kV
Short circuit protection acc. to IEC 60269-1 (control circuit fuse)	2		A gG
Utilization category of enabling switch according to EN 60947-5-1	AC-15	I _e 2 A U _e 24 V	
	DC-13	I _e 2 A U _e 24 V	
Utilization category of buttons and LEDs according to EN 60947-5-1	AC-15	24 V 400 mA	
	DC-13	24 V 100 mA	

Plug connector MR8 connection

Parameter	Value		Unit
Connection	Male connector		
Version	MR8 (8-pin)		
Connection cable conductor cross-section	without cable		mm ²
Degree of protection according to IEC 60529	IP 65 ¹⁾		
Rated impulse withstand voltage U _{imp}	0.8		kV
Short circuit protection acc. to IEC 60269-1 (control circuit fuse)	2		A gG
Utilization category of enabling switch according to EN 60947-5-1	AC-15	I _e 2 A U _e 24 V	
	DC-13	I _e 2 A U _e 24 V	
Utilization category of buttons and LEDs according to EN 60947-5-1	AC-15	24 V 400 mA	
	DC-13	24 V 100 mA	

Plug connector MR10 connection

Parameter	Value		Unit
Connection	Male connector		
Version	MR10 (10-pin)		
Connection cable conductor cross-section	without cable		mm ²
Degree of protection according to IEC 60529	IP 65 ¹⁾		
Rated impulse withstand voltage U _{imp}	0.8		kV
Short circuit protection acc. to IEC 60269-1 (control circuit fuse)	2		A gG
Utilization category of enabling switch according to EN 60947-5-1	AC-15	I _e 2 A U _e 24 V	
	DC-13	I _e 2 A U _e 24 V	

Plug connector HAN10 connection

Parameter	Value		Unit
Connection	Male connector		
Version	HAN10 (10-pin + PE)		
Connection cable conductor cross-section	8 x 0.34		mm ²
Degree of protection according to IEC 60529	IP 65 ¹⁾		
Rated impulse withstand voltage U _{imp}	0.8		kV
Short circuit protection acc. to IEC 60269-1 (control circuit fuse)	2		A gG
Utilization category according to EN 60947-5-1	AC-15	I _e 2 A U _e 230 V	
	DC-13	I _e 2 A U _e 24 V	

¹⁾ Only screwed tight with the related plug connector from page 64ff

Plug connector RC12 connection

Parameter	Value		Unit
Connection	Male connector		
Version	RC12 (11-pin + PE)		
Connection cable conductor cross-section	8 x 0.5 + 8 x 0.14	6 x 0.34	mm ²
Degree of protection according to IEC 60529	IP 67/IP 65 with additional elements ¹⁾		
Rated impulse withstand voltage U _{imp}	0.8		kV
Short circuit protection acc. to IEC 60269-1 (control circuit fuse)	2		A gG
Utilization category of enabling switch according to EN 60947-5-1	AC-15 DC-13	I _e 2 A U _e 24 V I _e 2 A U _e 24 V	
Utilization category of buttons and LEDs according to EN 60947-5-1	AC-15 DC-13	24 V 400 mA 24 V 100 mA	- -

Plug connector BS12 connection

Parameter	Value		Unit
Connection	Female connector		
Version	BS12 (12-pin)		
Connection cable conductor cross-section	8 x 0.5 + 8 x 0.14		mm ²
Degree of protection according to IEC 60529	IP 65 ¹⁾		
Rated impulse withstand voltage U _{imp}	0.8		kV
Short circuit protection acc. to IEC 60269-1 (control circuit fuse)	2		A gG
Utilization category of enabling switch according to EN 60947-5-1	AC-15 DC-13	I _e 2 A U _e 24 V I _e 2 A U _e 24 V	
Utilization category of buttons and LEDs according to EN 60947-5-1	AC-15 DC-13	24 V 400 mA 24 V 100 mA	

Plug connector RC17 connection

Parameter	Value		Unit
Connection	Male connector		
Version	RC17 (17-pin)		
Connection cable conductor cross-section	8 x 0.34	8 x 0.5 + 8 x 0.14	mm ²
Degree of protection according to IEC 60529	IP 67 or IP 65 with additional elements ¹⁾		
Rated impulse withstand voltage U _{imp}	0.8		kV
Short circuit protection acc. to IEC 60269-1 (control circuit fuse)	2		A gG
Utilization category of enabling switch according to EN 60947-5-1	AC-15 DC-13	I _e 2 A U _e 24 V I _e 2 A U _e 24 V	
Utilization category of buttons and LEDs according to EN 60947-5-1	AC-15 DC-13	24 V 400 mA 24 V 100 mA	

Plug connector RC17 Y-coded connection

Parameter	Value		Unit
Connection	Male connector		
Version	RC17 Y-coded (17-pin)		
Connection cable conductor cross-section	8 x 0.5 + 8 x 0.14		mm ²
Degree of protection according to IEC 60529	IP 67 or IP 65 with additional elements ¹⁾		
Rated impulse withstand voltage U _{imp}	0.8		kV
Short circuit protection acc. to IEC 60269-1 (control circuit fuse)	2		A gG
Utilization category of enabling switch according to EN 60947-5-1	AC-15 DC-13	I _e 2 A U _e 24 V I _e 2 A U _e 24 V	
Utilization category of buttons and LEDs according to EN 60947-5-1	AC-15 DC-13	24 V 400 mA 24 V 100 mA	

Plug connector UT23 connection

Parameter	Value		Unit
Connection	Male connector		
Version	UT23 (23-pin)		
Connection cable conductor cross-section	6 x 0.34		mm ²
Degree of protection according to IEC 60529	IP 67 ¹⁾		
Rated impulse withstand voltage U _{imp}	0.8		kV
Short circuit protection acc. to IEC 60269-1 (control circuit fuse)	2		A gG
Utilization category according to EN 60947-5-1	AC-15 DC-13	I _e 2 A U _e 24 V I _e 2 A U _e 24 V	

¹⁾ Only screwed tight with the related plug connector from page 64ff

Key-operated rotary switch

Parameter	Value	Unit
Housing material	PA black	
Ambient temperature	-25 to + 70	°C
Front degree of protection (installed)	IP 65	°C
Switching principle	Slow-action contact element	
Switching element	1 x NC + 1 x NO	A
Max. switching current	250	mA
Switching voltage	30	V
Contact resistance	≤ 200	mΩ
Connection	Tinned circuit board connection	mΩ

Selector switch

Parameter	Value	Unit
Front degree of protection (installed)	IP 65	
Single-hole bushing mounting	M7 x 0.75	
Detent	Max. 12, stop can be adjusted as required from 2 to 12 detent positions	°C
Output code	Binary-coded	
Max. switching current	0.5	A
Max. switching voltage	AC 115 V, DC 24 V on installation in P2 or HB.. housing	
Max. breaking capacity	10	VA
Contact resistance	≤ 6	mΩ
Connection	Soldered connection	mΩ

Illuminated pushbutton

Parameter	Value	Unit
Housing material	PA6 black	
Cover material	PC, transparent	
Ambient temperature	-25 to +70	°C
Front degree of protection (installed)	IP 65	
Switching principle	Snap-action contact element	
Switching element	NC + NO	
Max. switching current	4	A
Switching voltage	250 V, 12 ... 24 V on installation in P2 or HB.. housing	V
Contact resistance	≤ 200	mΩ
Connection	Soldered connection	
Built-in LED	Incandescent lamp, white, 21 mA 24 V	

Emergency stop button

Parameter	Value	Unit
Color of actuating head	red	
Color of bottom shell	yellow	
Ambient temperature	-25 to +60	°C
Max. number of switching elements	2	
Degree of protection	IP 65	

Emergency stop switching element

Parameter	Value	Unit
Contact element	1 x positively driven contact	
Utilization category according to IEC 947-5-1	DC-13 U _e 24 V I _e 3 A	
Connection	Soldered connection	

Plug connector series SS4 and BD4

Parameter	Value	Unit
Housing material	Brass matt chromium plated	
Number of pins	4 (3 + PE)	
Cable diameter	6 - 8	mm
Nominal voltage max.	250	V AC/DC
Degree of protection according to IEC 60529 (inserted)	IP 67	
Connection	Soldered connections 1.0 mm ²	

Plug connector C16-1

Parameter	Value	Unit
Housing material	Polyamide 6.6	
Number of pins	7 (6 + PE)	
Cable diameter max.	9.5	mm
Nominal voltage max.	230	V
Degree of protection according to IEC 60529 (inserted)	IP 67	
Connection	Crimp contacts 0.5 - 1.5 mm ²	

Plug connector series BS12

Parameter	Value	Unit
Housing material	Brass matt chromium plated	
Number of pins	12 (11 + PE)	
Cable diameter max.	12 - 14	mm
Nominal voltage max.	250	V AC/DC
Degree of protection according to IEC 60529 (inserted)	IP 67	
Connection	Soldered connections 1.0 mm ²	

Plug connector series RC12

Parameter	Value	Unit
Housing material	Metal	
Number of pins	12 (screen on the housing)	
	Male plug	Flange connector
Cable diameter max.	10	-
Connection	Crimp contacts 0.14 - 0.56 mm ²	Soldered connections 1.0 mm ²
Nominal voltage max.	230	V AC/DC
Degree of protection according to IEC 60529 (inserted)	IP 67	

Plug connector series RC17

Parameter	Value	Unit
Housing material	Metal	
Number of pins	17 (screen on the housing)	
	Male plug	Flange connector
Cable diameter max.	10	-
Connection	Crimp contacts 0.14 - 0.56 mm ²	Soldered connections 1.0 mm ²
Nominal voltage max.	230	V AC/DC
Degree of protection according to IEC 60529 (inserted)	IP 67	

Plug connector series UT23

Parameter	Value	Unit
Housing material	Metal	
Number of pins	23	
Nominal voltage max.	230	V AC/DC
Degree of protection according to IEC 60529 (inserted)	IP 67	
Connection	Crimp contacts 0.3 - 0.5 mm ²	

Index by item designation

Item	Order no.	Page	Item	Order no.	Page
Actuator-Z-G-C1932	084833	63	ZSA1A2G01AC2246	104231	51
BD4	002786	64	ZSA1A2G07A	097909	51
Blanking plug, 12-pin	073293	65	ZSA1A2L25AC1909	082557	51
Blanking plug, 17-pin	096159	65	ZSA1A2S05A	094321	51
Blanking plug, complete, 12-pin	073291	65	ZSA1A5G05AC1917	082524	51
BS12	002763	64	ZSA1A5G10AC1917	095144	51
BS12	071362	64	ZSA2-1	070734	59
Cable holder	047820	63	ZSA2-2	070735	59
Cable socket 6+PE	043861	64	ZSA2-4	070792	59
Cable, 12-core, coiled, 3900 mm	086721	58	ZSA2A1G05A	055402	32
Cable, 12-core, coiled, 5400 mm	086722	58	ZSA2A1G10A	055403	32
Cable, 12-core, straight cable, 10000 mm	087381	58	ZSA2A1L15AC1689	057089	32
Cable, 12-core, straight cable, 3500 mm	087379	58	ZSA2A1L25AC1689	072728	32
Cable, 12-core, straight cable, 5000 mm	087380	58	ZSA2A1S05A	055404	32
Cable, 23-core, coiled, 3900 mm	087408	58	ZSA2A2G02A	099371	32
Cable, 23-core, coiled, 5400 mm	087409	58	ZSA2A2G05A	055406	32
Cable, 23-core, straight cable, 10000 mm	087384	58	ZSA2A2G05CC1714	070741	38
Cable, 23-core, straight cable, 3500 mm	087382	58	ZSA2A2G10A	055407	32
Cable, 23-core, straight cable, 5000 mm	087383	58	ZSA2A2G15A	057007	32
Coiled cable with plug connector, 3.9 m	106391	67	ZSA2A2G20A	075807	32
Coiled cable with plug connector, 9 m	106392	67	ZSA2A2G25A	078939	32
Connection cable for enabling switch ZXE-111276	115123	67	ZSA2A2L12CC1725	070731	37
Emergency stop, 16 mm	096298	55	ZSA2A2S05A	055408	32
ES-XA1E-BV3UU02R	106435	55	ZSA2A2S05AC1643	057010	32
Female connector, 17-pin	106349	56	ZSA2A3G05A	070784	32
Flange connector, 12-pin	073290	65	ZSA2A3G10A	070785	32
Flange connector, 17-pin	077502	65	ZSA2A3S05A	070786	32
Flange connector, 17-pin	106360	56	ZSA2A4G05A	070764	32
Flange connector/23-pin/metal version	074384	66	ZSA2A4G05C-C2032	091547	38
Holder ZSM	102969	62	ZSA2A4G05C-C2041	092738	38
Holder ZSM with magnet	102965	62	ZSA2A4G10A	070765	32
Holder, complete	052406	63	ZSA2A4G20A	073300	32
Key-operated rotary switch	083639	57	ZSA2A4L25AC1689	086788	32
LED display, YE 106347	106347	56	ZSA2A4S05A	070766	32
Machine stop, 16 mm	106434	55	ZSA2AG05CC1770	073289	38
Magnetic holder	059340	63	ZSA2B2G05A	055410	34
Plug connector, 12-pin	073294	65	ZSA2B2G05B-C1662	057097	35
Plug connector, 17-pin	096481	65	ZSA2B2G10A	055411	34
Pushbutton, black	083640	57	ZSA2B2G10B	057100	36
Pushbutton, blue	086757	57	ZSA2B2G15CC1926	072870	35
Pushbutton, green	086754	57	ZSA2B4G05A	072961	34
Pushbutton, red	086753	57	ZSA2B4G10B	070788	36
Pushbutton, white	086755	57	ZSA2B4G10CC1830	077489	36
Pushbutton, yellow	086756	57	ZSA2B4S05A	085118	34
SD12-M	085648	64	ZSB054784	054784	43
Short-circuit plug with chain	083457	66	ZSB070894	070894	45
SS4	002787	64	ZSB070904	070904	46
ZSA0100873C2038	100873	36	ZSB072403	072403	46
ZSA072969C1983	072969	39	ZSB072645	072645	46
ZSA086707C1983	086707	39	ZSB077027	077027	45
ZSA092141C2038	092141	36	ZSB077029	077029	44
ZSA097567C2038	097567	36	ZSB077040	077040	40
ZSA099459C2038	099495	36	ZSB079832	079832	40
ZSA1-1	070750	60	ZSB083317	083317	39
ZSA1-2	070800	60	ZSB085058	085058	44
ZSA1-3	070736	60	ZSB085126	085126	39
			ZSB087821	087821	45
			ZSB090262	090262	46
			ZSB090489	090489	47
			ZSB092378	092378	39
			ZSB096900	096900	39
			ZSB100570	100570	44
			ZSB103161	103161	39

Index by order number

Order no.	Item	Page	Order no.	Item	Page
002763	BS12	64	073289	ZSA2AG05CC1770	38
002786	BD4	64	073290	Flange connector, 12-pin	65
002787	SS4	64	073291	Blanking plug, complete, 12-pin	65
043861	Cable socket 6+PE	64	073293	Blanking plug, 12-pin	65
047820	Cable holder	63	073294	Plug connector, 12-pin	65
052406	Holder, complete	63	073300	ZSA2A4G20A	32
052448	ZSE2-1	10	074384	Flange connector/23-pin/metal version	66
052449	ZSE2-2	10	075807	ZSA2A2G20A	32
054784	ZSB054784	43	077027	ZSB077027	45
055402	ZSA2A1G05A	32	077029	ZSB077029	44
055403	ZSA2A1G10A	32	077040	ZSB077040	40
055404	ZSA2A1S05A	32	077489	ZSA2B4G10CC1830	36
055406	ZSA2A2G05A	32	077502	Flange connector, 17-pin	65
055407	ZSA2A2G10A	32	078939	ZSA2A2G25A	32
055408	ZSA2A2S05A	32	079832	ZSB079832	40
055410	ZSA2B2G05A	34	082524	ZSA1A5G05AC1917	51
055411	ZSA2B2G10A	34	082557	ZSA1A2L25AC1909	51
055423	ZSR2A1G05A	41	083317	ZSB083317	39
055424	ZSR2A1G10A	41	083457	Short-circuit plug with chain	66
055425	ZSR2A1S05A	41	083477	ZSE2-4C1943	10
055427	ZSR2A2G05A	41	083639	Key-operated rotary switch	57
055428	ZSR2A2G10A	41	083640	Pushbutton, black	57
055429	ZSR2A2S05A	41	084833	Actuator-Z-G-C1932	63
055431	ZSR2B2G05A	42	085058	ZSB085058	44
055432	ZSR2B2G10A	42	085118	ZSA2B4S05A	34
057007	ZSA2A2G15A	32	085126	ZSB085126	39
057010	ZSA2A2S05AC1643	32	085648	SD12-M	64
057089	ZSA2A1L15AC1689	32	086707	ZSA086707C1983	39
057097	ZSA2B2G05B-C1662	35	086721	Cable, 12-core, coiled, 3900 mm	58
057100	ZSA2B2G10B	36	086722	Cable, 12-core, coiled, 5400 mm	58
059340	Magnetic holder	63	086753	Pushbutton, red	57
070731	ZSA2A2L12CC1725	37	086754	Pushbutton, green	57
070734	ZSA2-1	59	086755	Pushbutton, white	57
070735	ZSA2-2	59	086756	Pushbutton, yellow	57
070736	ZSA1-3	60	086757	Pushbutton, blue	57
070741	ZSA2A2G05CC1714	38	086788	ZSA2A4L25AC1689	32
070750	ZSA1-1	60	087379	Cable, 12-core, straight cable, 3500 mm	58
070752	ZSE2-2C1692	10	087380	Cable, 12-core, straight cable, 5000 mm	58
070762	ZSE2-4	10	087381	Cable, 12-core, straight cable, 10000 mm	58
070764	ZSA2A4G05A	32	087382	Cable, 23-core, straight cable, 3500 mm	58
070765	ZSA2A4G10A	32	087383	Cable, 23-core, straight cable, 5000 mm	58
070766	ZSA2A4S05A	32	087384	Cable, 23-core, straight cable, 10000 mm	58
070782	ZSE2-3	10	087408	Cable, 23-core, coiled, 3900 mm	58
070784	ZSA2A3G05A	32	087409	Cable, 23-core, coiled, 5400 mm	58
070785	ZSA2A3G10A	32	087821	ZSB087821	45
070786	ZSA2A3S05A	32	090262	ZSB090262	46
070788	ZSA2B4G10B	36	090489	ZSB090489	47
070792	ZSA2-4	59	091098	ZSE2-4C1801	11
070793	ZSG1-2	50	091336	ZXE-091336	12
070800	ZSA1-2	60	091547	ZSA2A4G05C-C2032	38
070894	ZSB070894	45	092141	ZSA092141C2038	36
070904	ZSB070904	46	092378	ZSB092378	39
071362	BS12	64	092738	ZSA2A4G05C-C2041	38
072403	ZSB072403	46	092996	ZSB2B4G05C-C2044	40
072645	ZSB072645	46	094321	ZSA1A2S05A	51
072728	ZSA2A1L25AC1689	32	095144	ZSA1A5G10AC1917	51
072870	ZSA2B2G15CC1926	35	095612	ZSB2A2G15A	39
072961	ZSA2B4G05A	34	096159	Blanking plug, 17-pin	65
072969	ZSA072969C1983	39	096298	Emergency stop, 16 mm	55
073260	ZSB2A2G05A	39	096481	Plug connector, 17-pin	65
073261	ZSB2A2G10A	39	096900	ZSB096900	39
073264	ZSB2A2G05C	40	097567	ZSA097567C2038	36
073265	ZSB2A2G10C	40	097609	ZSR2A4G05A	41



Representatives

International

Austria

EUCHNER GmbH
Aumühlweg 17-19/Halle 1C
2544 Leobersdorf
Tel. +43 720 010 200
Fax +43 720 010 200-20
info@euchner.at

Benelux

EUCHNER (BENELUX) BV
Visschersbuurt 23
3356 AE Papendrecht
Tel. +31 78 615-4766
Fax +31 78 615-4311
info@euchner.nl

Brazil

EUCHNER Com.Comp.
Eletronicos Ltda.
Av. Prof. Luiz Ignácio Anhaia Mello,
no. 4387
Vila Graciosa
São Paulo - SP - Brasil
CEP 03295-000
Tel. +55 11 29182200
Fax +55 11 23010613
euchner@euchner.com.br

Canada

EUCHNER Canada Inc.
2105 Fasan Drive
Oldcastle, ON NOR 1L0
Tel. +1 519 800-8397
Fax +1 519 737-0314
sales@euchner.ca

China

EUCHNER (Shanghai)
Trading Co., Ltd.
No. 15 building,
No. 68 Zhongchuang Road,
Songjiang
Shanghai, 201613, P.R.C
Tel. +86 21 5774-7090
Fax +86 21 5774-7599
info@euchner.com.cn

Czech Republic

EUCHNER electric s.r.o.
Trnkova 3069/117h
628 00 Brno
Tel. +420 533 443-150
Fax +420 533 443-153
info@euchner.cz

Denmark

Duelco A/S
Systemvej 8 - 10
9200 Aalborg SV
Tel. +45 7010 1007
Fax +45 7010 1008
info@duelco.dk

Estonia

Sähkölehto OÜ
Hobujaama 4
Tallinn 10151
Tel. +372 56 645 400
office@sahkolehto.fi

Finland

Sähkölehto Oy
Holkkitie 14
00880 Helsinki
Tel. +358 9 7746420
office@sahkolehto.fi

France

EUCHNER France S.A.R.L.
Parc d'Affaires des Bellevues
Allée Rosa Luxembourg
Bâtiment le Colorado
95610 ERAGNY sur OISE
Tel. +33 1 3909-9090
Fax +33 1 3909-9099
info@euchner.fr

Hungary

EUCHNER Magyarország Kft.
FSD Park 2,
2045 Törökbálint
Tel. +36 1 919 0855
Fax +36 1 919 0857
info@euchner.hu

India

EUCHNER (India) Pvt. Ltd.
401, Bremen Business Center,
City Survey No. 2562,
University Road
Aundh, Pune - 411007
Tel. +91 20 64016384
Fax +91 20 25885148
info@euchner.in

Israel

Ilan & Gavish Automation Service Ltd.
26 Shenkar St. Qiryat Arie 49513
P.O. Box 10118
Petach Tikva 49001
Tel. +972 3 9221824
Fax +972 3 9240761
mail@ilan-gavish.com

Italy

TRITECNICA SpA
Viale Lazio 26
20135 Milano
Tel. +39 02 541941
Fax +39 02 55010474
info@tritecnica.it

Japan

EUCHNER Co., Ltd.
1662-3 Komakiharashinden
Komaki-shi, Aichi-ken
485-0012, Japan
Tel. +81 568 42 0157
Fax +81 568 42 0159
info@euchner.jp

Korea

EUCHNER Korea Co., Ltd.
115 Gasan Digital 2 - Ro
(Gasan-dong, Daeryung
Technotown 3rd Rm 810)
153 - 803 Kumchon-Gu, Seoul
Tel. +82 2 2107-3500
Fax +82 2 2107-3999
info@euchner.co.kr

Mexico

EUCHNER México S de RL de CV
Conjunto Industrial PK Co.
Carretera Estatal 431 km. 1+300
Ejido El Colorado, El Marqués
76246 Querétaro, México
Tel. +52 442 402 1485
Fax +52 442 402 1486
info@euchner.mx

Poland

EUCHNER Sp. z o.o.
Kraśnińskiego 29
40-019 Katowice
Tel. +48 32 252 20 09
Fax +48 32 252 20 13
info@euchner.pl

Portugal

PAM Servicos Tecnicos Industriais Lda.
Rua de Timor - Pavilhao 2A
Zona Industrial da Abelheira
4785-123 Trofa
Tel. +351 252 418431
Fax +351 252 494739
pam@mail.telepac.pt

Republic of South Africa

RUBICON
ELECTRICAL DISTRIBUTORS
4 Reith Street, Sidwell
6061 Port Elizabeth
Tel. +27 41 451-4359
Fax +27 41 451-1296
sales@rubiconelectrical.com

Romania

First Electric SRL
Str. Ritmului Nr. 1 Bis
Ap. 2, Sector 2
021675 Bucuresti
Tel. +40 21 2526218
Fax +40 21 3113193
office@firstelectric.ro

Singapore

BM Safety Singapore Pte Ltd.
3 Ang Mo Kio Industrial Park 2A
#07-04 Ang Mo Kio Tech 1
Singapore 568050
Tel. +65 6744 8018
Fax +65 6744 1929
sales@bmsafety.com.sg

Slovakia

EUCHNER electric s.r.o.
Trnkova 3069/117h
628 00 Brno
Tel. +420 533 443-150
Fax +420 533 443-153
info@euchner.cz

Slovenia

SMM proizvodni sistemi d.o.o.
Jaskova 18
2000 Maribor
Tel. +386 2 4502326
Fax +386 2 4625160
franc.kit@smm.si

Spain

EUCHNER, S.L.
Gurutzegi 12 - Local 1
Poligono Belartza
20018 San Sebastian
Tel. +34 943 316-760
Fax +34 943 316-405
info@euchner.es

Sweden

Censit AB
Box 331
33123 Värnamo
Tel. +46 370 691010
Fax +46 370 18888
info@censit.se

Switzerland

EUCHNER AG
Falknisstrasse 9a
7320 Sargans
Tel. +41 81 720-4590
Fax +41 81 720-4599
info@euchner.ch

Taiwan

Daybreak Int'l (Taiwan) Corp.
3F, No. 124, Chung-Cheng Road
Shihlin 11145, Taipei
Tel. +886 2 8866-1234
Fax +886 2 8866-1239
day111@ms23.hinet.net

Turkey

EUCHNER Endüstriyel Emniyet
Teknolojileri Ltd. Şti.
Hattat Bahattin Sok.
Ceylan Apt. No. 13/A
Göztepe Mah.
34730 Kadıköy / Istanbul
Tel. +90 216 359-5656
Fax +90 216 359-5660
info@euchner.com.tr

United Kingdom

EUCHNER (UK) Ltd.
Unit 2 Petre Drive,
Sheffield
South Yorkshire
S4 7PZ
Tel. +44 114 2560123
Fax +44 114 2425333
sales@euchner.co.uk

USA

EUCHNER USA Inc.
6723 Lyons Street
East Syracuse, NY 13057
Tel. +1 315 701-0315
Fax +1 315 701-0319
info@euchner-usa.com

EUCHNER USA Inc.
Detroit Office
130 Hampton Circle
Rochester Hills, MI 48307
Tel. +1 248 537-1092
Fax +1 248 537-1095
info@euchner-usa.com

Germany

Augsburg

EUCHNER GmbH + Co. KG
Ingenieur- und Vertriebsbüro
Julius-Spokojny-Weg 8
86153 Augsburg
Tel. +49 821 56786540
Fax +49 821 56786541
peter.klopfer@euchner.de

Berlin

EUCHNER GmbH + Co. KG
Ingenieur- und Vertriebsbüro
Ulmenstraße 115a
12621 Berlin
Tel. +49 30 50508214
Fax +49 30 56582139
alexander.walz@euchner.de

Chemnitz

EUCHNER GmbH + Co. KG
Ingenieur- und Vertriebsbüro
Am Vogelherd 2
09627 Bobritzsch-Hilbersdorf
Tel. +49 37325 906000
Fax +49 37325 906004
jens.zehrtner@euchner.de

Düsseldorf

EUCHNER GmbH + Co. KG
Ingenieur- und Vertriebsbüro
Tippgarten 3
59427 Unna
Tel. +49 2308 9337284
Fax +49 2308 9337285
christian.schimke@euchner.de

Essen

Thomas Kreißl
fördern - steuern - regeln
Hackenbergweg 8a
45133 Essen
Tel. +49 201 84266-0
Fax +49 201 84266-66
info@kreisslessen.de

Freiburg

EUCHNER GmbH + Co. KG
Ingenieur- und Vertriebsbüro
Steige 5
79206 Breisach
Tel. +49 7664 403833
Fax +49 7664 403834
peter.seifert@euchner.de

Lübeck

EUCHNER GmbH + Co. KG
Ingenieur- und Vertriebsbüro
Am Stadtrand 13
23556 Lübeck
Tel. +49 451 88048371
Fax +49 451 88184364
martin.pape@euchner.de

Nürnberg

EUCHNER GmbH + Co. KG
Ingenieur- und Vertriebsbüro
Steiner Straße 22a
90522 Oberasbach
Tel. +49 911 6693829
Fax +49 911 6696722
ralf.paulus@euchner.de

Stuttgart

EUCHNER GmbH + Co. KG
Ingenieur- und Vertriebsbüro
Kohlhammerstraße 16
70771 Leinfelden-Echterdingen
Tel. +49 711 7597-0
Fax +49 711 7597-303
oliver.laier@euchner.de
uwe.kupka@euchner.de

Wiesbaden

EUCHNER GmbH + Co. KG
Ingenieur- und Vertriebsbüro
Adolfsallee 3
65185 Wiesbaden
Tel. +49 611 98817644
Fax +49 611 98895071
giancarlo.pasquesi@euchner.de



EUCHNER

More than safety.



Support hotline

You have technical questions about our products or how they can be used?
For further questions please contact your local sales representative.



Comprehensive download area

You are looking for more information about our products?
You can simply and quickly download operating instructions, CAD or ePLAN data and accompanying software for our products at www.euchner.com.



Customer-specific solutions

You need a specific solution or have a special requirement?
Please contact us. We can manufacture your custom product even in small quantities.



EUCHNER near you

You are looking for a contact at your location? Along with the headquarters in Leinfelden-Echterdingen, the worldwide sales network includes 18 subsidiaries and numerous representatives in Germany and abroad – you will definitely also find us near you.

www.euchner.com

EUCHNER GmbH + Co. KG

Kohlhammerstraße 16
70771 Leinfelden-Echterdingen
Germany
Tel. +49 711 7597-0
Fax +49 711 753316
info@euchner.de
www.euchner.com

E Engineering
Partner

S Systems
Integrator

V Value-Added
Distributor

248-373-1600 • morrell-group.com • orders@morrellinc.com

MI • IN • IL • OH • ON, CAN

MorrellGroup 
Evolution in Controls

EUCHNER

More than safety.