

Compact Modules CKK / CKR

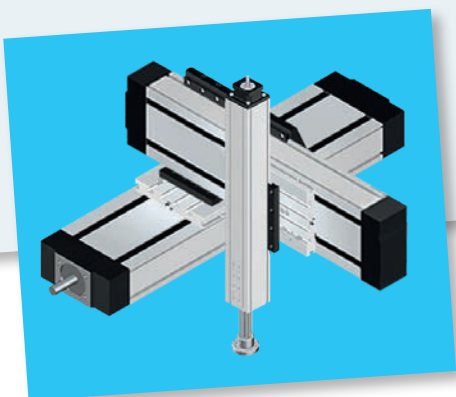
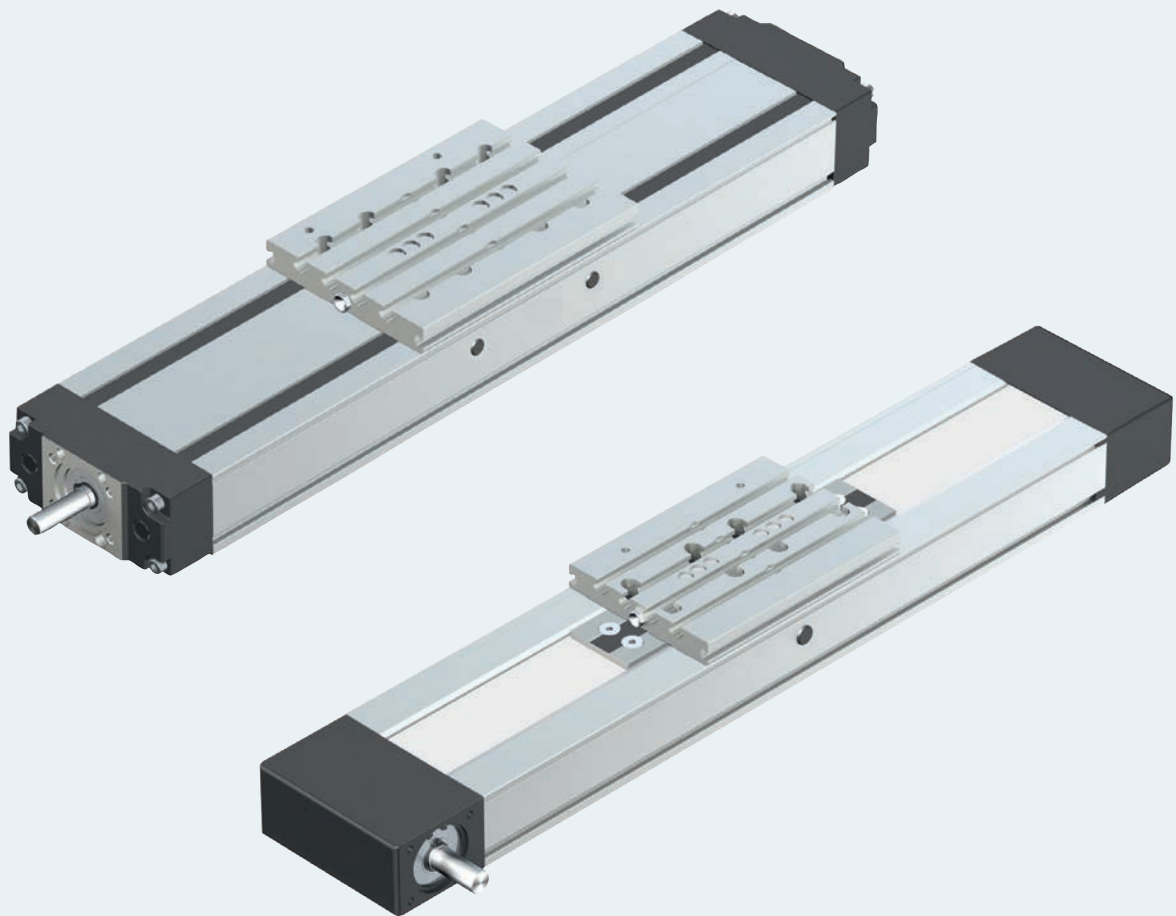

Identification system for short product names

Compact Modules are identified by the type designation and size.

Example		C	K	K	-	110	-	NN	-	1
System	=	Compact Module								
Guideway	=	Kugelschienenführung (Ball Rail System)								
Drive	=	Kugelgewindetrieb (Ball Screw Assembly) ZahnRiementrieb (Toothed belt drive)								
Size	=	070 / 090 / 080 / 110 / 145 / 200								
Version	=	N ormalausführung = Standard version)								
Generation	=	Product generation 1								

Changes/additions at a glance**Catalog set-up**

Catalog integration:

- ▶ "Lubrication / cover Resist": R999001349 (2017-03)
- ▶ New chapter "Project planning" contains:
Calculation principles, sample calculation
- ▶ New chapter "Abbreviations"

Technical modifications

- ▶ Integration MS2N motors
- ▶ MSK motors omitted

Contents

Contents	3	Attachments and accessories	74
Product description	4	Mounting/mounting accessories	74
Lubrication versions	6	Connection plates	78
Form of delivery	8	Cover	83
Overview of models with load capacities	10	Connecting shafts	84
Compact Modules with Ball Screw Assembly (CKK)	12	Nozzle pipe	87
Product overview	12	Frequency meter	87
Structural design	16	Motors	88
Technical data	18	Motor attachment kits	
General technical data	18	according to customer specification	88
Drive data	20	IndraDyn S - MSM servo motors	90
Technical data for CKK-200 with screw support	22	IndraDyn S - MS2N servo motors	92
General technical data	22	Switching system	96
Drive data	24	Overview of attachment variants	96
Diagrams	28	Sensors	100
Permissible drive torque	28	Switches	108
Permissible speed	30	Extensions	112
Configuration, order	32	Connectors	114
CKK-070	32	Adapters	115
CKK-090	34	Distributors	116
CKK-110	36	Combination examples	120
CKK-145	38	Socket and plug	122
CKK-200	40	EasyHandling	124
Dimensional drawings	42	Service and information	128
Frame	42	Operating conditions	128
Carriages	46	Lubrication	130
Motor attachment	48	CKK Compact Modules	130
Compact Modules with toothed belt drive (CKR)	50	CKR Compact Modules	132
Product overview	50	Lubricants	134
Structural design	51	Parameterization (start-up)	136
Technical data	52	Documentation	137
General technical data	52	Project planning/calculation	138
Drive data	52	Calculation principles	138
Gear data	54	Drive dimensioning	142
Configuration, order	56	Sample calculations	148
CKR-070	56	Abbreviations	156
CKR-090	58	Order example	158
CKR-110	60	Inquiry/order form	159
CKR-145	62	Further information	160
CKR-200	64	Notes	162
Dimensional drawings	66		
Frame	66		
Carriages	70		
Motor attachment	72		
Adapter flange	73		

Product description

Characteristic features

- ▶ Five fine-tuned sizes based on a compact precision aluminum profile with two integrated pre-tensioned Ball Rail Systems
- ▶ Identical external dimensions between Compact Modules types CKK and CKR.
- ▶ Four different lube versions (see the following pages and the "Lubrication" chapter)
- ▶ Ready-to-install Compact Modules in any length up to L_{max}
- ▶ Aluminum carriages available in different versions depending on load

Further highlights

- ▶ Flexible thanks to options
- ▶ Ready-to-install with various attachment parts
- ▶ Center holes for simple combination with other linear motion systems and connection elements
- ▶ Economical maintenance thanks to one-point lubrication feature (grease lubrication) from both sides or via the carriage or via a connection plate

CKK Compact Modules

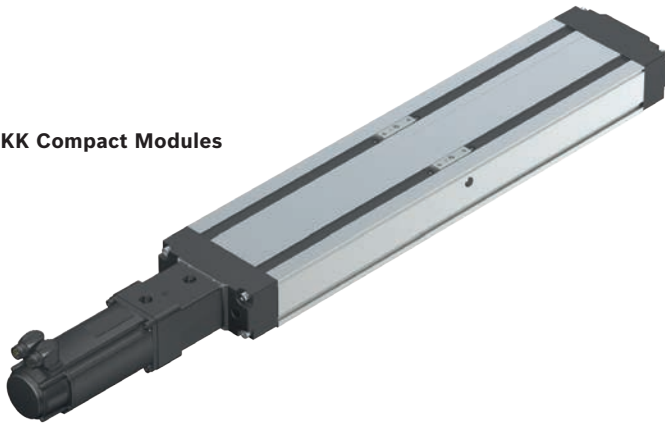

CKR Compact Modules



Compact Modules are available as complete solutions with motor, controller, and control system. For more information, see the "Motors" and "EasyHandling" chapters

CKK Compact Modules with Ball Rail System and Ball Screw Assembly

- ▶ Drive via precision Ball Screw Assembly
- ▶ Screw support for the realization of high speeds on long assembly lengths for CKK-200
- ▶ Protection of installation elements through a cover plate and two cover strips; optionally increased protection thanks to "Resist" cover
- ▶ Repeatability of up to ± 0.005 mm

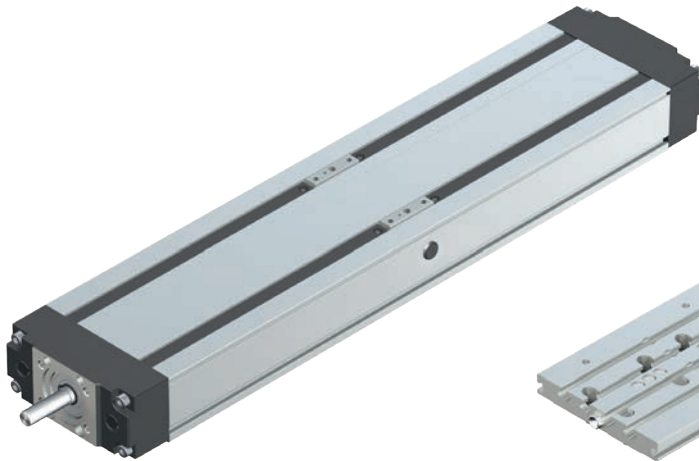

Connection plates

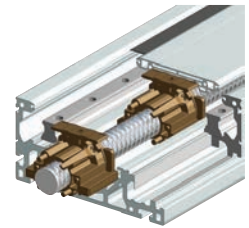

"Resist" cover

Screw support SPU for
CKK-200**CKR Compact Modules with Ball Rail System and toothed belt drive**

- ▶ Realization of greater lengths of up to 10,000 mm
- ▶ Pre-tensioned toothed belt
- ▶ Intelligent toothed belt guide protects inner components
- ▶ Repeatability of up to ± 0.05 mm



Connection plates

Lubrication versions

Two drive versions:

- ▶ CKK Compact Modules with Ball Rail System and Ball Screw Assembly
- ▶ CKR Compact Modules with Ball Rail System and toothed belt drive

Four different lube versions

- ▶ Standard lubrication (LSS)
- ▶ Preserved (LPG)
- ▶ Carriage with connection plate prepared for connection to central lubrication systems for liquid grease (LCF)
- ▶ Carriage with connection plate prepared for connection to central lubrication systems for oil (LCO)

Versions for oil and liquid grease lubrication prepared for connection to central lubrication systems

- ▶ High operational reliability through automated relubrication
- ▶ Need-based maintenance reduces consumption of lubricant, while ensuring high availability
- ▶ More degrees of freedom as lubrication is dependent on position and mounting location
- ▶ Low-cost unmanned maintenance

Notes:

LSS:

- ▶ Initial lubrication by Bosch Rexroth
- ▶ Relubrication using manual grease gun

LPG:

- ▶ Ball Rail System and Ball Screw Assembly only with corrosion prevention
- ▶ Relubrication using manual grease gun
- ▶ Basic lubrication required

LCF:

- ▶ Prepared for connection to central lubrication systems for liquid grease (NLGI grade 00 in accordance with DIN 51818)
- ▶ Lubrication with liquid grease only via single-line piston distributor system
- ▶ Basic lubrication required

LCO:

- ▶ Prepared for connection to central lubrication systems for oil
- ▶ Oil lubrication only via single-line piston distributor system
- ▶ Runner block and Ball Screw Assembly nut with integrated non-return valves
- ▶ Basic lubrication required

CKK Compact Modules
Lube version LSS, LPG

- ▶ Grease lubrication with manual grease gun via frame, carriage or via connection plate



Connection plates

CKR Compact Modules
Lube version LSS, LPG

- ▶ Grease lubrication with manual grease gun via frame, carriage or via connection plate

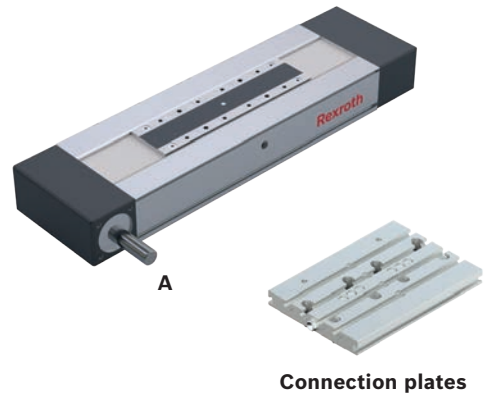

Connection plates

Lube version LCF, LCO

- ▶ 3 lube fittings
- ▶ Prepared for connection to central lubrication systems



- A** Drive side
- 1** Lube connection, runner block left
- 2** Lube connection, runner block right
- 3** Lube connection, Ball Screw Assembly

Lube version LCF, LCO

- ▶ 2 lube fittings
- ▶ Prepared for connection to central lubrication systems

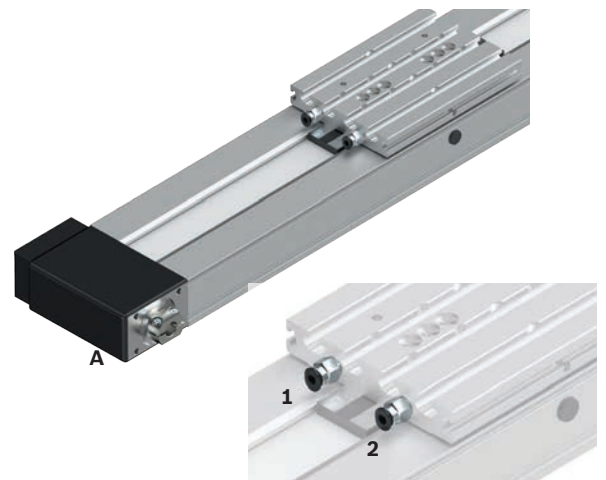

- A** Drive side
- 1** Lube connection, runner block left
- 2** Lube connection, runner block right

Form of delivery

Compact Modules with Ball Rail System and Ball Screw Assembly or toothed belt drive are delivered completely assembled.

Motor attachment

If a combination of motor and motor attachment has been selected, then the components are attached as shown in the figure, which also shows the location of the motor connector.

When ordering motor attachments without motor, not all parts can be mounted.

Final assembly must then be carried out by the customer.

All necessary instructions and parameters for professional assembly are included.

Available options

Cable duct, mounting duct, switch, switching cam and socket with plugs are included as loose parts.

Lubrication

Depending on the lube version, Compact Modules are delivered with initial greasing.

For information on lubricants, see section "Lubrication".

Documentation



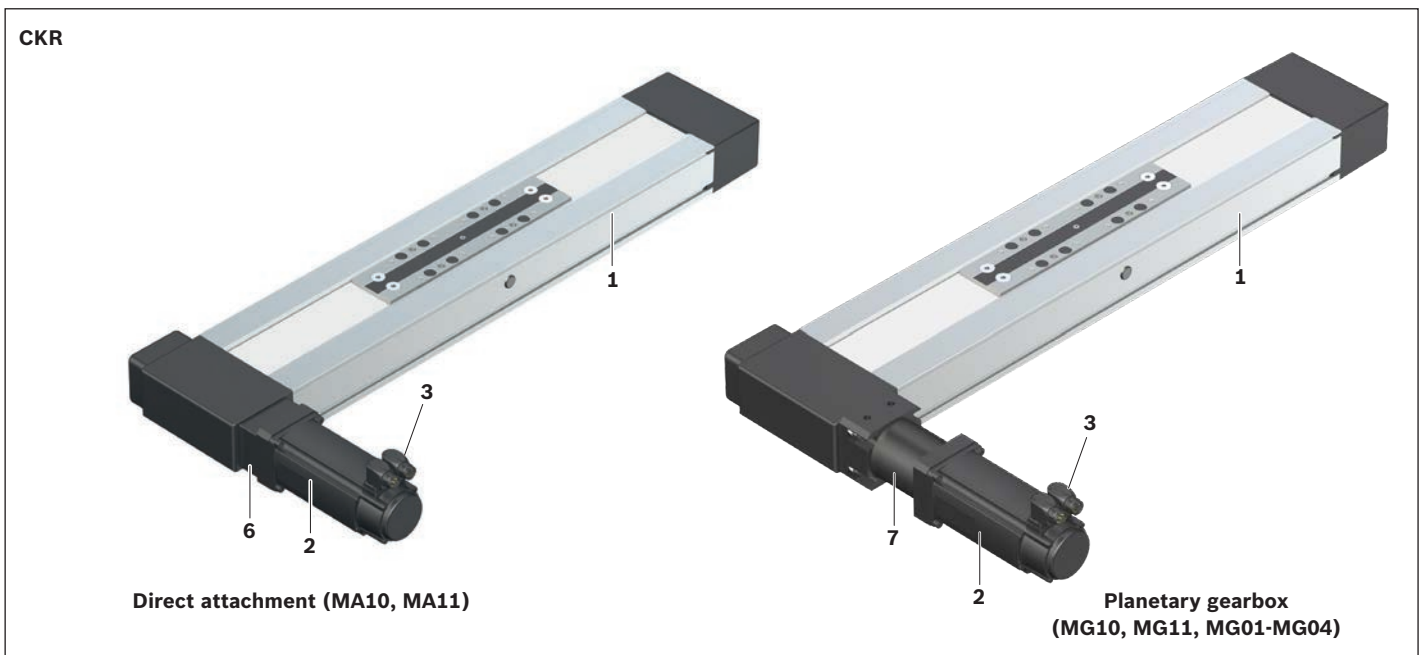
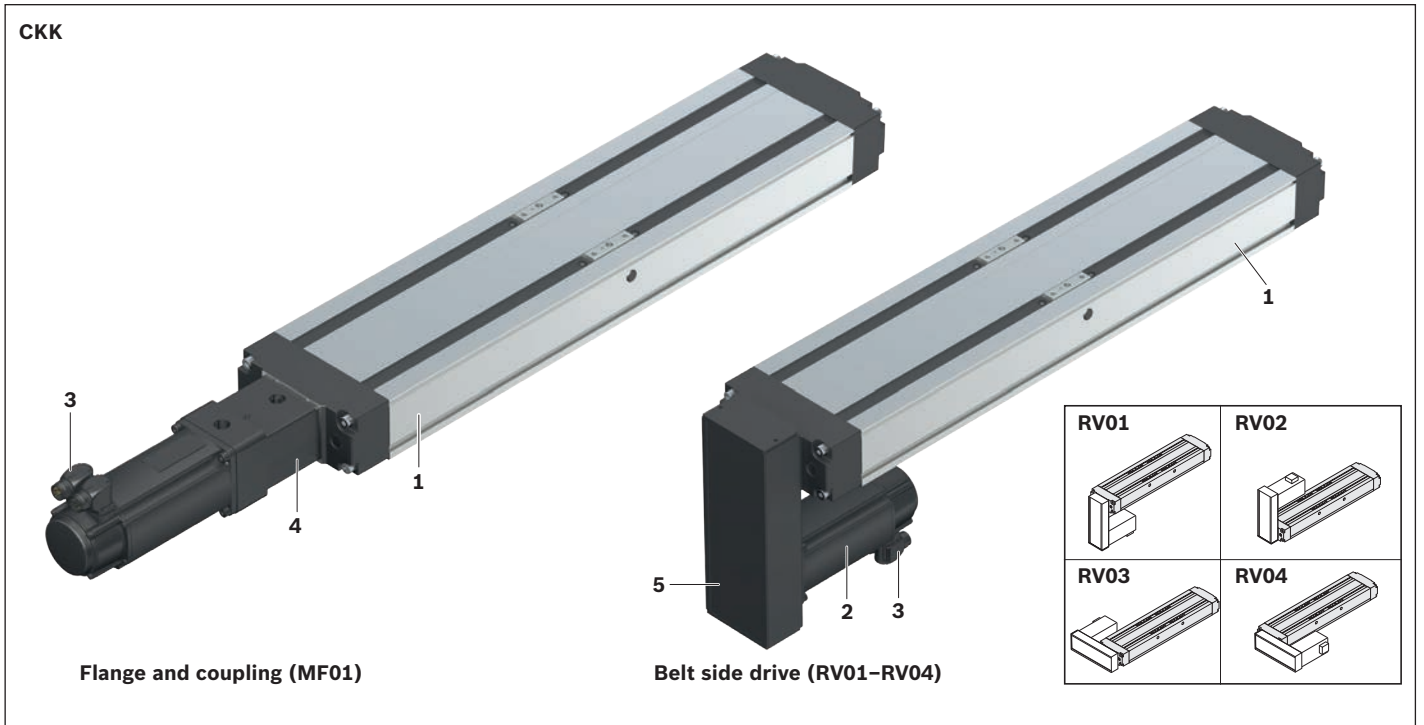

Each Compact Modules is supplied with the appropriate documentation.

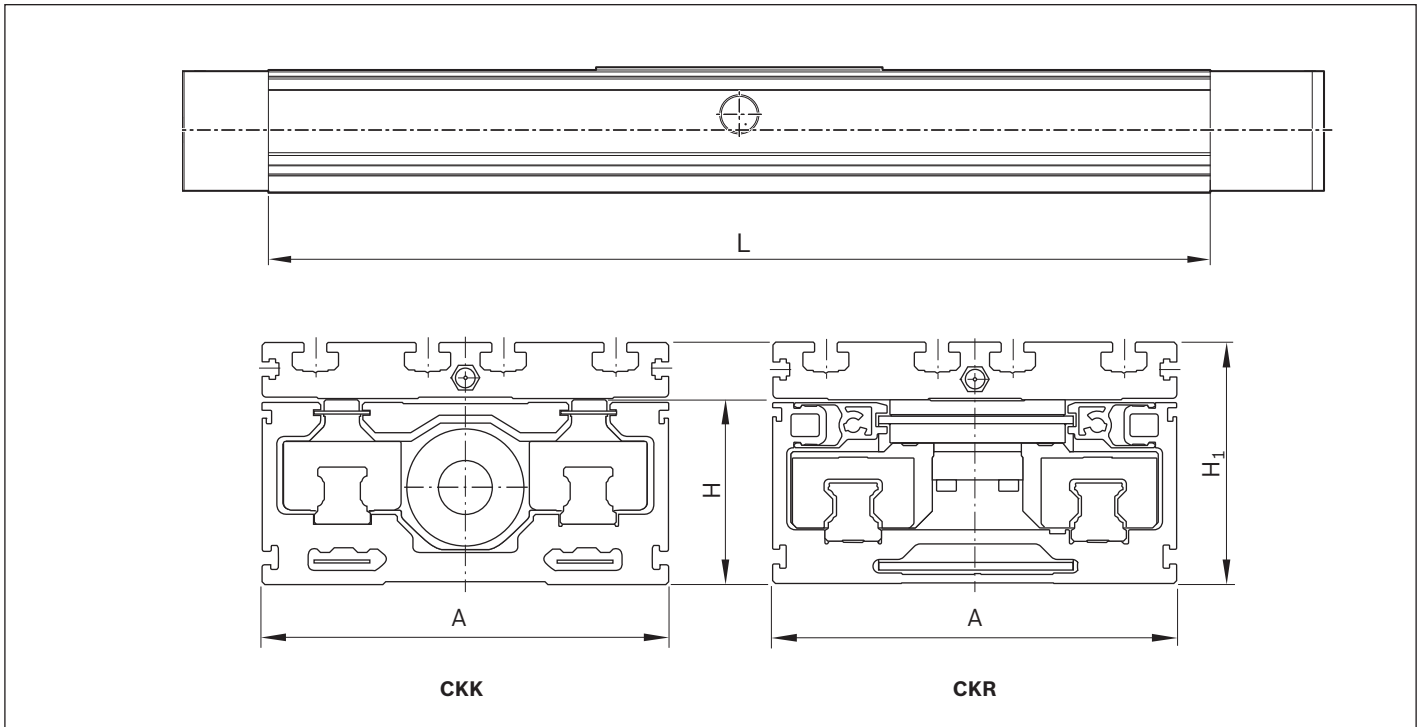

- 1** Linear motion system
- 2** Motor
- 3** Motor connector
- 4** Flange and coupling
- 5** Belt side drive
- 6** Direct attachment (flange)
- 7** Gearing

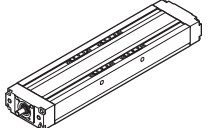
Overview of models with load capacities

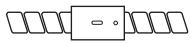
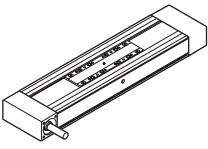

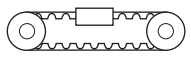
Compact Modules	Type	Guideway	Drive
	CKK	 Ball Rail System	 Ball Screw Assembly
	CKR	 Ball Rail System	 Toothed belt drive

Note on dynamic load capacities and moments

Determination of the dynamic load capacities and moments is based on a total travel of 100,000 m. Often only 50,000 m of total travel are actually stipulated. For comparison: Multiply values C , M_t and M_L by a factor of 1.26.

Size	070			090			110			145			200		
	A	H	H ₁	A	H	H ₁	A	H	H ₁	A	H	H ₁	A	H	H ₁
Dimensions (mm)	70	32	44.5	90	40	56	110	50	66	145	65	85	200	100	127
L_{max} (mm)	650			750			1,500			1,800			2,200 ¹⁾		
Dyn. load capacity C_{gw}²⁾ (N)	3,830			7,505			32,035			76,025			121,185		
L_{max} (mm)	1,500			5,500			5,500			5,500			10,000		
Dyn. load capacity C_{gw}²⁾ (N)	3,830			7,505			32,035			76,025			121,185		

¹⁾ Up to 5500 mm are possible with screw support (SPU).

²⁾ The maximum permitted dynamic values are specified here.
They vary depending on the carriage length.

Compact Modules with Ball Screw Assembly (CKK)

Product overview

Features

- ▶ Five fine-tuned sizes based on a compact precision aluminum profile with two integrated pre-tensioned Ball Rail Systems
- ▶ Four different lube versions
- ▶ Ready-to-install Compact Modules in any length up to L_{\max}
- ▶ Driven by precision Ball Screw Assembly in rolled design tolerance grade T7 in accordance with DIN 69051 with single nut set to zero-clearance
- ▶ High linear speeds thanks to large leads with high precision over long lengths
- ▶ Aluminum carriages available in different lengths
- ▶ Protection of installation elements through a cover plate and two cover strips; optionally increased protection thanks to "Resist" cover
- ▶ Low-cost maintenance
- ▶ Repeatability of up to ± 0.005 mm

Further highlights

- ▶ Flexible thanks to selectable options
- ▶ Center holes for simple combination with other Linear Motion Systems and connection elements
- ▶ Extensive accessories for connection and clamping elements
- ▶ Nameplate with parameters for easy start-up

Attachments

- ▶ Motor attachments with flange and coupling or via a belt side drive
- ▶ Motor attachment kits according to customer specification
- ▶ Maintenance-free servo motors with selectable brake and attached feedback
- ▶ Magnetic sensors, switch activation without additional switch flag
- ▶ Socket and plug
- ▶ Mounting duct made of aluminum for sensors

Design/options for guideway (frame), carriages, connection plates

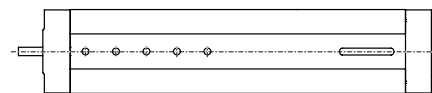
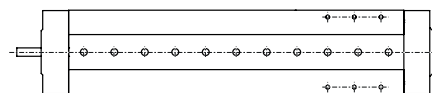
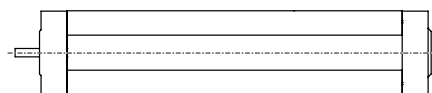

Guideway (frame)

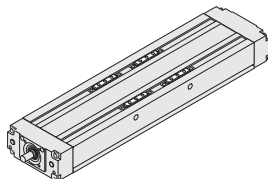
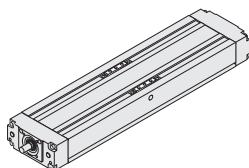

Carriages

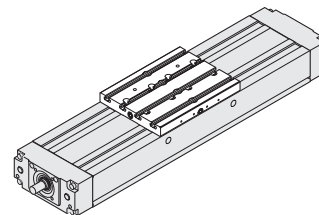

Connection plates

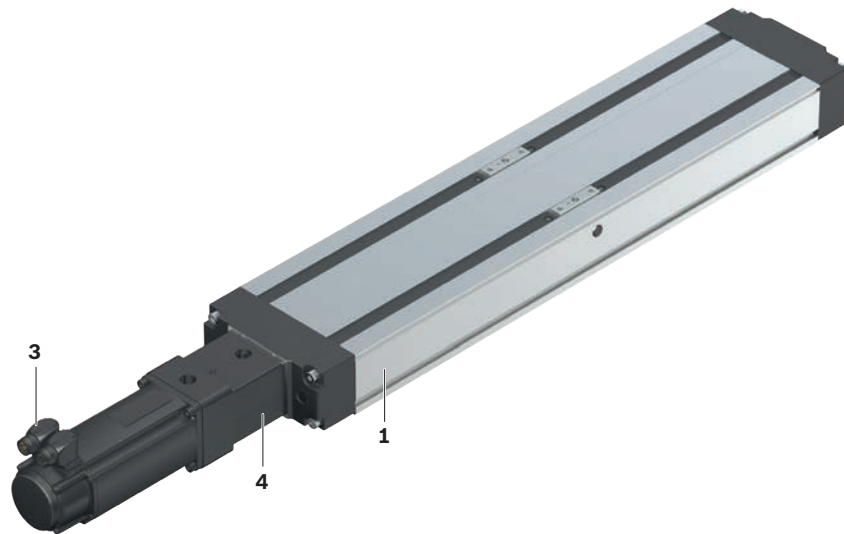

Flange and coupling (MF01)

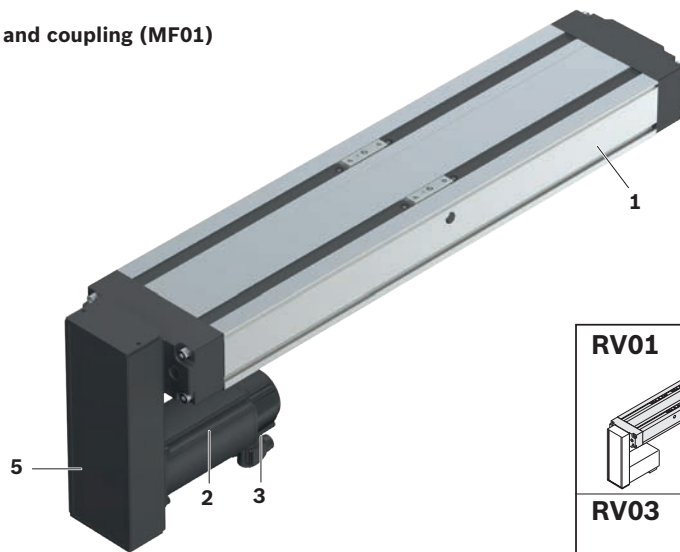

Belt side drive (RV01-RV04)

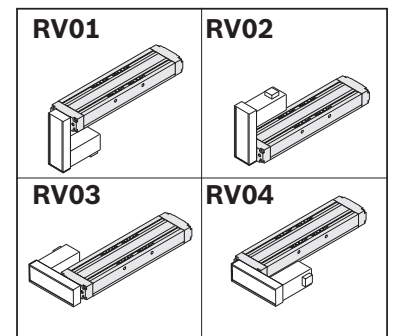

- 1 Linear motion system
- 2 Motor
- 3 Motor connector
- 4 Flange and coupling
- 5 Belt side drive

Screw support for Compact Modules CKK-200

Structural design:

- ▶ Guidance of the screw supports in the frame.

Features:

- ▶ High speed over longer lengths of up to 5,500 mm.
- ▶ Elastomer buffer provides cushioning between carriage and screw supports.
- ▶ Screw supports are maintenance-free.
- ▶ Screw supports are protected by the cover sheet and cover strips.
- ▶ The screw supports prevent the cover sheet from sagging in all directions.

 **Screw support suitable for horizontal operation only**

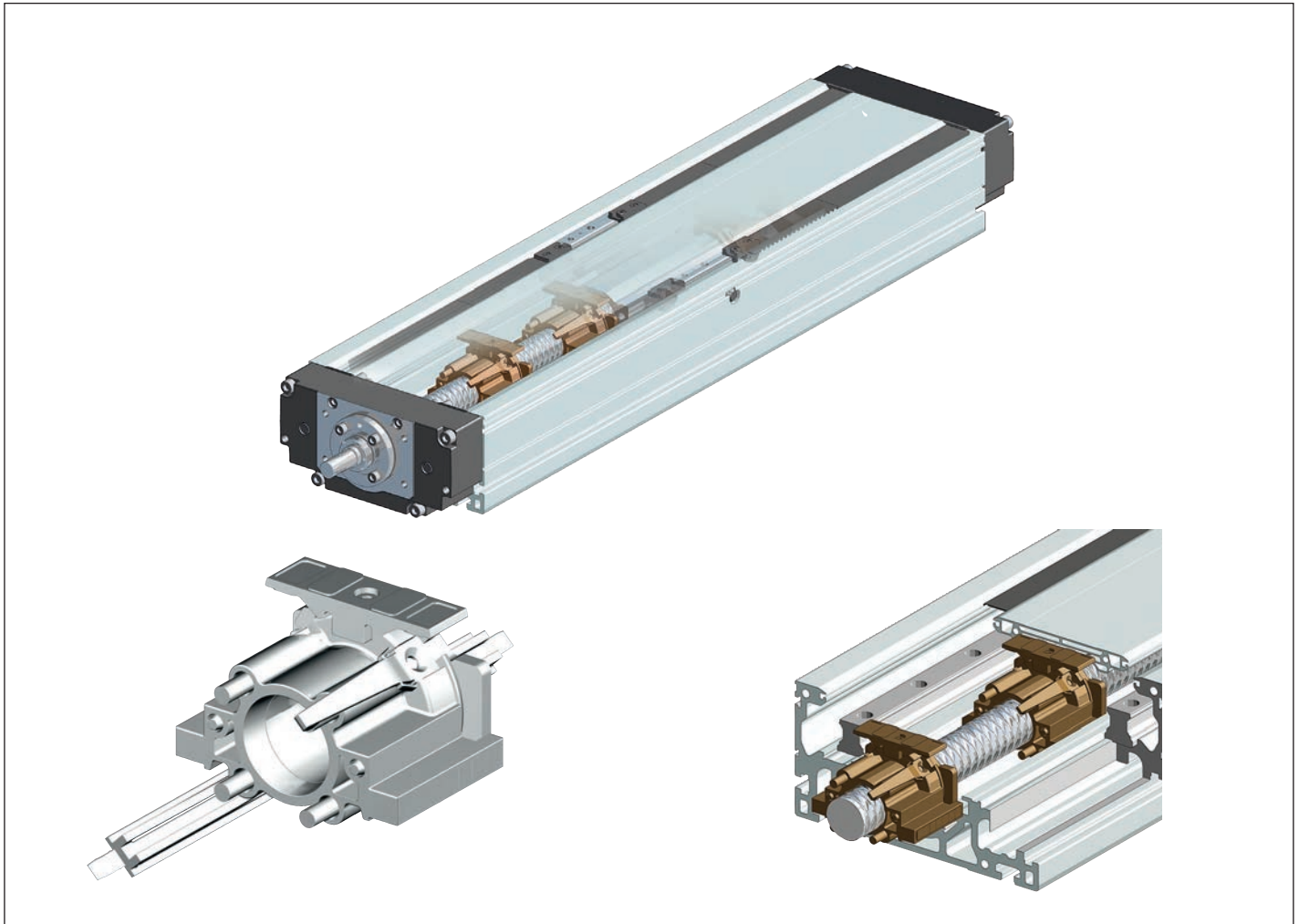

"Resist" cover

Structural design:

- ▶ Sizes: CKK -110, -145, -200
- ▶ Possible for version with connection plate

Features:

- ▶ Increased protection thanks to the toothed sealing profile
- ▶ The integrated guideway on the carriage ensures the sealing profile interlocks perfectly
- ▶ Sealing profile made of flexible FKM – material
- ▶ Free of LABS (substances harmful to paint structure)
- ▶ Replaceable sealing profile
- ▶ The sealing profile has a short-term temperature resistance of up to 300°C
- ▶ Suitable for exposure to dry chips with broken chips of aluminum and component handling during welding application
- ▶ Selectable with all lube versions

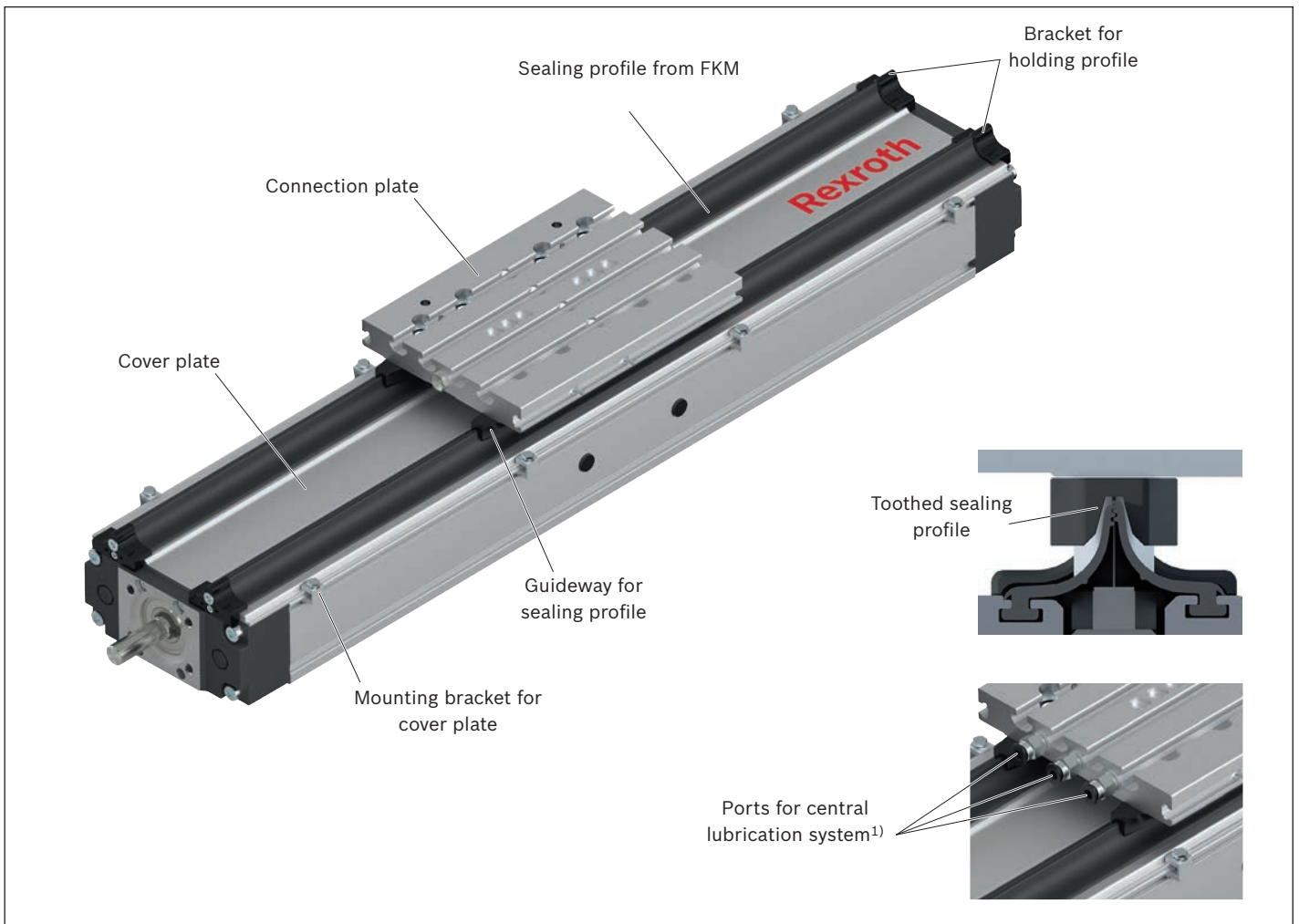

¹⁾ see "Lubrication" chapter

Structural design

Structural design CKK

- 1 Ball Screw Assembly with zero-backlash single nut
- 2 Drive-side cross tie
- 3 Carriage with integrated runner block
- 4 Cover plate
- 5 Cover strip made of reinforced PU strip
- 6 End block
- 7 Frame

Attachments:

- 8 Connection plate
- 9 Magnetic sensor
- 10 Mounting channel
- 11 Socket/plug
- 12 Flange and coupling
- 13 Belt side drive
- 14 Motor

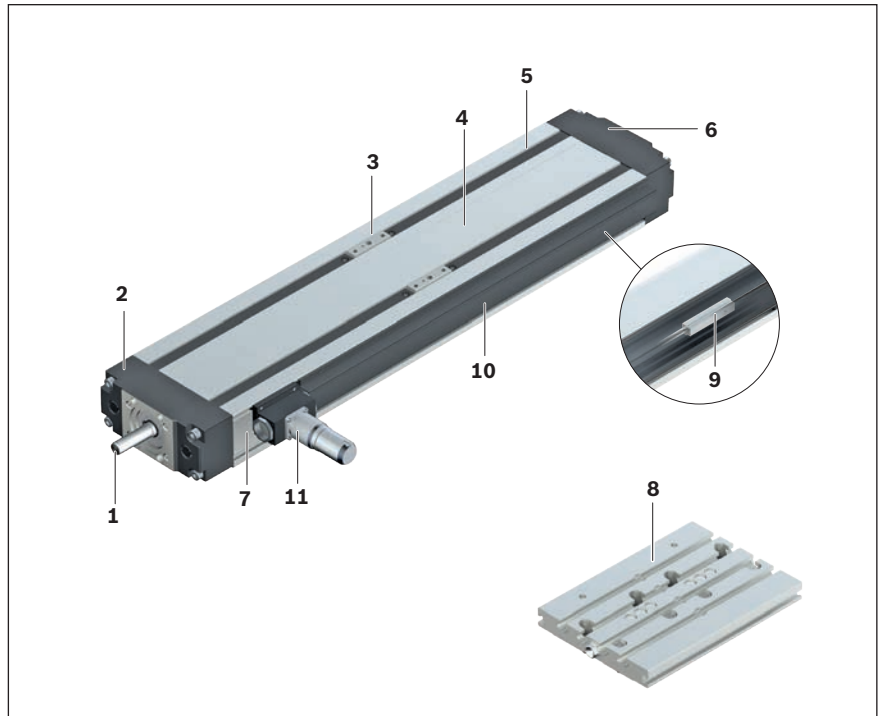

Motor attachment – flanged type and coupling

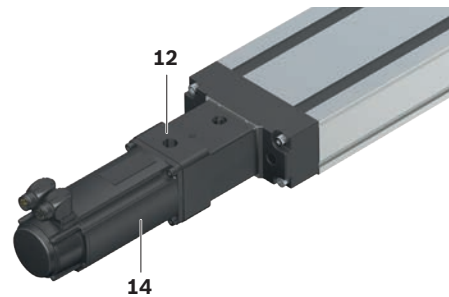

Motor attachment – belt side drive

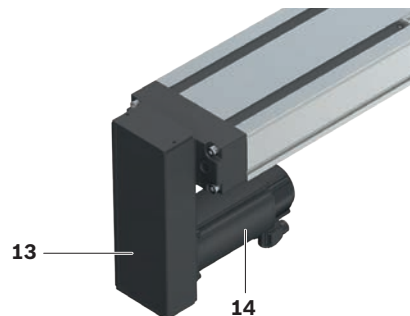

Motor attachment with flange and coupling

A motor can be attached to all Compact Modules with Ball Screw Assembly by means of flange and coupling. The motor mount serves to fasten the motor to the Compact Modules and acts as a closed housing for the coupling. The motor's drive torque is transmitted stress-free through the coupling to the Compact Modules drive shaft.

Our standard couplings compensate for the system's thermal expansion.

- 1 Motor
- 2 Flange
- 3 Coupling
- 4 Compact module

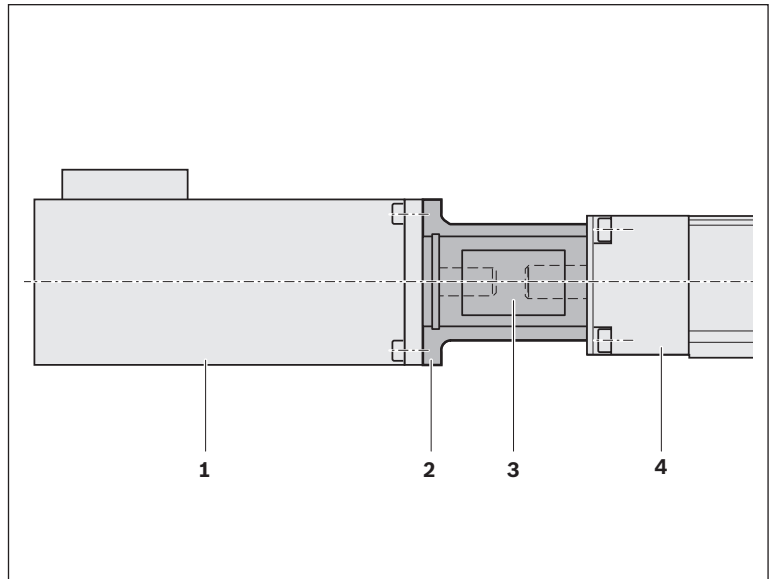

Structural design belt side drive

All Compact Modules with Ball Screw Assembly offer the option of attaching the motor via a belt side drive.

This makes the overall length shorter than when attaching the motor with flange and coupling.

The space-saving, closed pulley housing serves as protection for the belt and as a motor bracket.

In addition, various gear ratios are also available (depending on size):

- ▶ $i = 1$
- ▶ $i = 1.5$
- ▶ $i = 2$

The belt side drive can be mounted in four different directions:

- ▶ below, above (RV01 and RV02)
- ▶ left, right (RV03 and RV04)

- 1 Pulley housing made of anodized aluminum
- 2 Compact Modules
- 3 Support bearing at the screw journal in size CKK-070
- 4 Toothed belt drive
- 5 Motor
- 6 Toothed belt drive
- 7 Cover
- 8 Belt pulleys with tensioning units
- 9 Cover plate

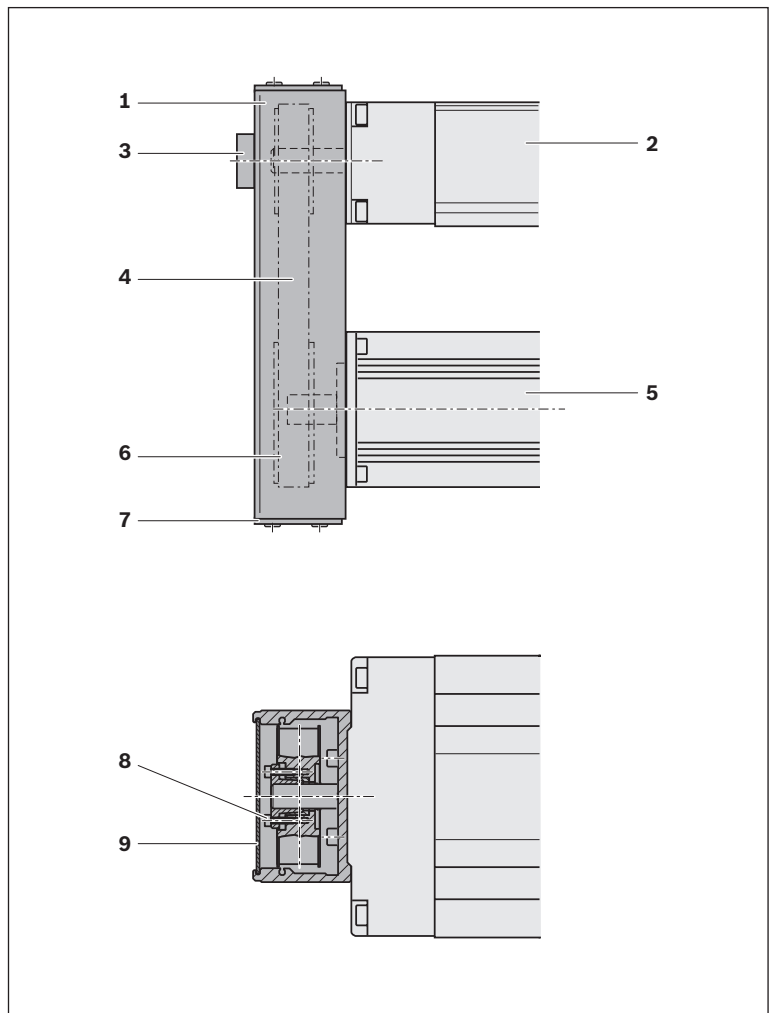

Technical data

General technical data

Observe the "Project planning/calculation" chapter.

CKK	Carriage			Additional length		Min. travel range	Max. length	Rexroth Ball Screw Assembly	Dynamic characteristics					
	Connection plate		$L_W^{3)}$	Connection plate					Load ratings			Load moments		
	without ¹⁾	with ²⁾		without	with				C_{gw}	C_{bs}	C_{fb}	M_t	$M_L^{5)}$	
L_{ca}	L_{ca}	L_{ad}	L_{ad}	$s_{min}^{4)}$	L_{max}	$d_0 \times P$	(N)	(N)	(N)	(Nm)	(Nm)			
-070	32	60	-	30	2	40	650	8 x 2.5	2,360	2,370	1,600	47	7	
	73	95	-	30	8	40	650	8 x 2.5	3,830	2,370	1,600	77	111	
-090	35	60	-	50	25	40	750	12 x 2	4,620	2,420	6,900	125	16	
								12 x 5						4,100
								12 x 10						2,700
	100	125	-	50	25	40	750	12 x 2	7,505	2,420	6,900	203	244	
								12 x 5						4,100
								12 x 10						2,700
variable min. 101 max. 235	-	variable min. 66 max. 200	50	-	40	750	12 x 2	7,505	2,420	6,900	203	3.75 x L_W		
						12 x 5	4,100							
						12 x 10	2,700							
-110	39	60	-	51	30	50	1,500	16 x 5	19,720	13,320	13,400	651	136	
								16 x 10						10,350
								16 x 16						6,800
	124	155	85	51	20	50	1,500	16 x 5	32,035	13,320	13,400	1,057	1,361	
								16 x 10						10,350
								16 x 16						6,800
variable min. 125 max. 289	-	variable min. 86 max. 250	51	-	50	1,500	16 x 5	32,035	13,320	13,400	1,057	16.01 x L_W		
						16 x 10	10,350							
						16 x 16	6,800							
-145	49	80	-	61	30	60	1,800	20 x 5	46,800	15,480	17,000	2,059	400	
								20 x 20						9,810
								20 x 40						12,600
								25 x 10						16,920
	149	190	100	61	20	60	1,800	20 x 5	76,025	15,480	17,000	3,345	3,801	
								20 x 20						9,810
20 x 40								12,600						
variable min. 150 max. 349	-	variable min. 101 max. 300	61	-	60	1,800	25 x 10	76,025	15,480	17,000	3,345	38.01 x L_W		
						20 x 5	9,810							
						20 x 20	12,600							
-200	79.5	190	-	120.5	10	80	2,200	32 x 5	74,600	23,310	26,000	4,849	1,053	
								32 x 10						34,200
								32 x 20						21,240
								32 x 32						21,060
	254.5	305	175	120.5	70	80	2,200	32 x 5	121,185	23,310	26,000	7,877	10,604	
								32 x 10						34,200
32 x 20								21,240						
variable min. 255.5 max. 429.5	-	variable min. 176 max. 350	120.5	-	80	2,200	32 x 32	121,185	23,310	26,000	7,877	60.59 x L_W		
						32 x 5	21,060							
						32 x 10	34,200							
							32 x 20	21,240						
							32 x 32	21,060						

1) In the "without connection plate" version, carriage length L_{ca} corresponds to the dimension of the outer edge to outer edge of the fastening bridges.

Dynamic parameters and maximum permissible loads are valid only when connecting the fixing screw via customer attachment.

2) The connection plate is mounted on the "without connection plate" carriage version.

In the "with connection plate" version, carriage length L_{ca} corresponds to the length of the connection plate.

3) A variable center-to-center distance L_W is only possible for the "without connection plate" carriage design.

The variable center-to-center distance is freely selectable between minimum and maximum distance in millimeters steps.

Maximum permissible loads							Planar moments of inertia		Point of force application	
Moments			Forces				I_y (cm ⁴)	I_z (cm ⁴)	Connection plate	
$M_{x \max}$ (Nm)	$M_{y \max}^{5)}$ (Nm)	$M_{z \max}^{5)}$ (Nm)	$F_{y \max}$ (N)	$F_{z1 \max}$ (N)	$F_{z2 \max}$ (N)	without Z_1 (mm)			with Z_1 (mm)	
47	7	7	1,270	2,360	2,360	12.10	63.3	19.2	31.7	
77	111	60	2070	3830	3830					
112	16	16	2,490	4,620	4,140	14.32	124.4	23.2	39.2	
203	244	132	4,050	7,505	7,505					
203	3.75 x L _W	2.03 x L _W	4,050	7,505	7,505					
198	32	32	3,480	6,000	6,000	37.74	318.7	26.7	42.7 (60.7) ⁶⁾	
396	510	240	5,650	12,000	12,000					
396	6 x L _W	2.82 x L _W	5,650	12,000	12,000					
634	100	100	8,410	14,400	14,400	114.10	986.4	31.6	51.6 (71.6) ⁶⁾	
1,267	1,440	683	13,660	28,800	28,800					
1,267	14.4 x L _W	6.83 x L _W	13,660	28,800	28,800					
1,375	299	299	12,265	21,150	21,150	612.00	3,008.0	36.0	63.0 (86.4) ⁶⁾	
2,750	3,701	1,744	19,925	42,300	42,300					
2,750	21.14 x L _W	9.97 x L _W	19,925	42,300	42,300					

4) Minimum required travel distance to ensure a reliable lubrication distribution.

5) For the variable L_W, M_x, M_{y max} and M_{z max} must be determined according to the selected center-to-center distance L_W.

6) "Resist" cover → "Resist" chapter.

Drive data

Observe the "Project planning/calculation" chapter.

CKK	BASA	Carriage		Constant weight calculation		Moved system mass	
		Connection plate without	with	$k_{g \text{ fix}}$ (kg)	$k_{g \text{ var}}$ (kg/mm)	Connection plate without ¹⁾	with
	$d_0 \times P$ (mm)	L_{ca} (mm)	L_{ca} (mm)			m_{ca} (kg)	m_{ca} (kg)
-070	8 x 2.5	32	60	0.29	0.0031	0.15	0.26
		73	95			0.25	0.42
-090	12 x 2	35	60	0.50	0.0054	0.36	0.54
		100	125			0.59	0.96
	12 x 5	35	60			0.36	0.54
		100	125			0.59	0.96
	12 x 10	35	60			0.36	0.54
		100	125			0.59	0.96
-110	16 x 5	39	60	0.91	0.0094	0.52	0.75
		124	155			0.86	1.45
	16 x 10	39	60			0.52	0.75
		124	155			0.86	1.45
	16 x 16	39	60			0.52	0.75
		124	155			0.86	1.45
-145	20 x 5	49	80	1.91	0.0179	1.21	1.71
		149	190			2.06	3.26
	20 x 20	49	80			1.21	1.71
		149	190			2.06	3.26
	20 x 40	49	80			1.21	1.71
		149	190			2.06	3.26
	25 x 10	49	80			1.21	1.71
		149	190			2.06	3.26
-200	32 x 5	79.5	190	4.06	0.0296	3.20	5.50
		254.5	305			5.20	8.90
	32 x 10	79.5	190			3.20	5.50
		254.5	305			5.20	8.90
	32 x 20	79.5	190			3.20	5.50
		254.5	305			5.20	8.90
	32 x 32	79.5	190			3.20	5.50
		254.5	305			5.20	8.90

¹⁾ For the carriage version with variable center-to-center distance L_w the larger value is valid.

	Constant mass moment of inertia				Frictional torque ¹⁾	Max. acceleration	Max. travel speed	Max. drive torque:
	Connection plate without ¹⁾	with	$k_{J \text{ var}}$ (kgmm)	$k_{J \text{ m}}$ (mm ²)				
$k_{J \text{ fix}}$ (kgmm ²)	$k_{J \text{ fix}}$ (kgmm ²)							
	0.769	0.786	0.004	0.158	0.07	50.0	see "Diagrams" chapter	see "Diagrams" chapter
	0.785	0.812						
	1.279	1.298	0.013	0.101	0.13	48.4		
	1.303	1.340			0.14			
	1.454	1.568	0.011	0.633	0.15	50.0		
	1.599	1.834			0.16			
	2.138	2.594	0.011	2.533	0.18	50.0		
	2.720	3.658			0.20			
	5.088	5.234	0.031	0.633	0.37	50.0		
	5.303	5.677			0.40			
	6.076	6.658	0.031	2.533	0.40	50.0		
	6.937	8.432			0.43			
	8.161	9.652	0.034	6.485	0.42	50.0		
	10.365	14.191			0.48			
	22.564	22.880	0.084	0.633	0.48	39.8		
	23.102	23.862			0.52			
	34.029	39.950	0.081	10.132	0.60	50.0		
	42.641	54.800			0.68			
	70.856	91.120	0.086	40.528	0.70	50.0		
	105.305	153.939			0.86			
	26.335	27.601	0.239	2.533	0.60	50.0		
	28.488	31.528			0.65			
	71.348	72.867	0.605	0.633	1.10	17.9		
	72.741	75.147			1.20			
	76.612	82.691	0.640	2.533	1.10	30.7		
	82.185	91.810			1.20			
	93.299	117.676	0.639	10.132	1.15	50.0		
	115.590	154.092			1.25			
	127.391	189.642	0.617	25.938	1.25	50.0		
	184.455	283.020			1.35			

Technical data for CKK-200 with screw support

General technical data

Observe the "Project planning/calculation" chapter.

CKK	Carriage		BASA	Screw support	Additional length		Max. length	Min. travel distance	Dynamic characteristics					
	Connection plate				Connection plate				Load ratings			Load moments		
	without ¹⁾	with ²⁾			without	with			C_{gw}	C_{bs}	C_{fb}	M_t	M_L	
L_{ca} (mm)	L_{ca} (mm)	$d_0 \times P$ (mm)	L_{ad} (mm)	L_{ad} (mm)	L_{max} (mm)	s_{min} ³⁾ (mm)	C_{gw} (N)	C_{bs} (N)	C_{fb} (N)	M_t (Nm)	M_L (Nm)			
-200	79.5	190	32 x 5	0	120.5	10	2,200	80	74,600	26,000	4,849	1,053		
				1	235.5	-	3,500							23,310
				2	360.5	-	4,600							
				3	485.5	-	5,500							
			0	120.5	10	2,200	34,200							
			1	235.5	-	3,500								
			2	360.5	-	4,600								
			3	485.5	-	5,500								
			0	120.5	10	2,200	21,240							
			1	235.5	-	3,500								
			2	360.5	-	4,600								
			3	485.5	-	5,500								
	0	120.5	10	2,200	21,060									
	1	235.5	-	3,500										
	2	360.5	-	4,600										
	3	485.5	-	5,500										
	254.5	305	32 x 5	0	120.5	70	2,200	80	121,185	26,000	7,877	10,604		
				1	235.5	185	3,600							23,310
				2	360.5	310	4,700							
				3	485.5	435	5,500							
			0	120.5	70	2,200	34,200							
			1	235.5	185	3,600								
			2	360.5	310	4,700								
			3	485.5	435	5,500								
0			120.5	70	2,200	21,240								
1			235.5	185	3,600									
2			360.5	310	4,700									
3			485.5	435	5,500									
0	120.5	70	2,200	21,060										
1	235.5	185	3,600											
2	360.5	310	4,700											
3	485.5	435	5,500											

¹⁾ In the "without connection plate" version, carriage length L_{ca} corresponds to the dimension of the outer edge to outer edge of the fastening bridges. Dynamic parameters and maximum permissible loads are valid only when connecting the fixing screw via customer attachment.
²⁾ The connection plate is mounted on the "without connection plate" carriage version. In the "with connection plate" version, carriage length L_{ca} corresponds to the length of the connection plate.
³⁾ Minimum required travel distance to ensure a reliable lubrication distribution.

Maximum permissible loads							Constants		Planar moments of inertia		Point of force application Connection plate	
Moments			Forces				Mass calculation		I_y (cm ⁴)	I_z (cm ⁴)	without	with
$M_{x \max}$ (Nm)	$M_{y \max}$ (Nm)	$M_{z \max}$ (Nm)	$F_{y \max}$ (N)	$F_{z1 \max}$ (N)	$F_{z2 \max}$ (N)	$k_g \text{ fix}$ (kg)	$k_g \text{ var}$ (kg/mm)	Z_1 (mm)			Z_1 (mm)	
1,375	299	299	12,265	21,150	21,150	4.06	0.0296	612.00	3,008.0	36.0	63.0	
2,750	3,701	1,744	19,925	42,300	42,300	4.06	0.0296	612.00	3,008.0	36.0	63.0	

Drive data

Observe the "Project planning/calculation" chapter.

CKK	BASA	Screw support	Carriage		Constant mass calculation		Moved system mass	
			Connection plate without L_{ca} (mm)	with L_{ca} (mm)	$k_{g\ fix}$ (kg)	$k_{g\ var}$ (kg/mm)	Connection plate without ¹⁾ m_{ca} (kg)	with m_{ca} (kg)
-200	32 x 5	0	79.5	190	4.06	0.0296	3.20	5.50
		1					3.40	-
		2					3.60	-
		3					3.80	-
		0	254.5	305			5.20	8.90
		1					5.40	9.10
		2					5.60	9.30
		3					5.80	9.50
	32 x 10	0	79.5	190			3.20	5.50
		1					3.40	-
		2					3.60	-
		3					3.80	-
		0	254.5	305			5.20	8.90
		1					5.40	9.10
		2					5.60	9.30
		3					5.80	9.50
	32 x 20	0	79.5	190			3.20	5.50
		1					3.40	-
		2					3.60	-
		3					3.80	-
		0	254.5	305			5.20	8.90
		1					5.40	9.10
		2					5.60	9.30
		3					5.80	9.50
	32 x 32	0	79.5	190			3.20	5.50
		1					3.40	-
		2					3.60	-
		3					3.80	-
0		254.5	305	5.20	8.90			
1				5.40	9.10			
2				5.60	9.30			
3				5.80	9.50			

¹⁾ For the carriage version with variable center-to-center distance L_w the larger value is valid.

Constant mass moment of inertia		Frictional torque ¹⁾		Max. acceleration	Max. speed	Max. drive torque			
Connection plate		$k_{J\text{ var}}$ (kgmm)	$k_{J\text{ m}}$ (mm ²)	M_{Rs} (Nm)	a_{max} (m/s ²)	v_{max} (m/s)	M_p (Nm)		
without ¹⁾	with								
$k_{J\text{ fix}}$ (kgmm ²)	$k_{J\text{ fix}}$ (kgmm ²)								
71.348	72.867	0.605	0.633	1.10	17.9	see "Diagrams" chapter	see "Diagrams" chapter		
71.474	-			1.20					
71.601	-			1.20					
71.728	-			1.40					
72.741	75.147	0.605	0.633	1.20					
72.867	75.274			1.30					
72.994	75.400			1.30					
73.121	75.527			1.50					
76.612	82.691	0.640	2.533	1.10				30.7	see "Diagrams" chapter
77.119	-			1.20					
77.625	-			1.40					
78.132	-			1.50					
82.185	91.810	0.640	2.533	1.20					
82.691	92.317			1.30					
83.198	92.823			1.50					
83.705	93.330			1.60					
93.299	117.616	0.639	10.132	1.15	50.0	see "Diagrams" chapter			
95.326	-			1.30					
97.352	-			1.50					
99.378	-			1.70					
115.590	154.092	0.639	10.132	1.25					
117.676	156.118			1.40					
119.643	158.145			1.60					
121.669	160.171			1.80					
127.391	189.642	0.617	25.938	1.25	50.0	see "Diagrams" chapter			
132.578	-			1.40					
137.766	-			1.70					
142.953	-			1.90					
184.455	283.020	0.617	25.938	1.35					
189.642	288.207			1.50					
194.830	293.395			1.80					
200.018	298.583			2.00					

Drive data for motor attachment via belt side drive

Observe the "Project planning/calculation" chapter.

CKK	Motor	BASA (mm) d ₀ x P	up to L ¹⁾ (mm)	M _{sd} ²⁾ (Nm)		J _{sd} (10 ⁻⁶ kgm ²)		M _{Rsd} (Nm)	m _{sd} (kg)		B _t	
				i = 1	i = 1.5	i = 1	i = 1.5		i = 1	i = 1.5	i = 1	i = 1.5
-070	MSM019B	8 x 2.5	450	0.71	0.47	10.7	4.1	0.06	0.28	0.26	6 AT3	6 AT3
	MS2N03 MSM031B	8 x 2.5	450	0.71	0.47	45.6	17.7	0.15	0.63	0.61	10 AT3	10 AT3
	-090	MS2N03 MSM031C	12 x 2	750	0.79	0.53	38.0	14.0	0.15	0.53	0.48	10 AT3
12 x 5			750	2.39	1.59							
12 x 10			750	2.73	1.82							
-110	MS2N03 MSM031C	16 x 5	1,250	3.17	2.11	41.0	16.0	0.15	0.53	0.48	10 AT3	10 AT3
		16 x 10	1,500	3.17	2.11							
		16 x 16	1,500	3.17	2.11							
	MS2N04 MSM041B	16 x 5	850	6.76	4.51	240.0	82.0	0.40	1.34	1.24	16 AT5	16 AT5
		16 x 10	1,150	7.66	5.11							
		16 x 16	1,450	7.66	5.11							
-145	MS2N04 MSM041B	20 x 5	1,350	8.22	5.48	250.0	85.0	0.40	1.42	1.31	16 AT5	16 AT5
		20 x 20	1,800	8.22	5.48							
		20 x 40	1,800	8.22	5.48							
		25 x 10	1,800	8.22	5.48							

CKK	Motor	BASA (mm) d ₀ x P	up to L ¹⁾ (mm)	M _{sd} ²⁾ (Nm)		J _{sd} (10 ⁻⁶ kgm ²)		M _{Rsd} (Nm)	m _{sd} (kg)		B _t	
				i = 1	i = 2	i = 1	i = 2		i = 1	i = 2	i = 1	i = 2
-145	MS2N05	20 x 5	1,150	11.00	5.50	1,310	217	0.45	3.5	3.1	25 AT5	25 AT5
		20 x 20	1,800	17.73	8.87							
		20 x 40	1,800	17.73	8.87							
		25 x 10	1,800	17.73	8.87							
-200	MS2N06	32 x 5	2,200	19.00	9.50	1,400	260	0.50	3.8	3.5	25 AT5	32 AT5
		32 x 10	2,200	19.21	12.30							
		32 x 20	2,200	19.21	12.30							
		32 x 32	2,200	19.21	12.30							

¹⁾ For greater lengths, the permissible drive torque is determined from the length-variable value M_p of the linear motion system in accordance with the diagram → "Project planning/calculation" chapter

²⁾ Values for M_{sd} do not factor in motor torque.

Drive data for motor attachment via flange and coupling

CKK	Motor	Coupling		Flange and coupling
		M_{cN} (Nm)	J_c (10^{-6} kgm ²)	
-070	MS2N03	3.7	7.00	0.30
	MSM019B	1.9	2.10	0.15
	MSM031B	3.7	7.00	0.30
-090	MS2N03	13.0	12.20	0.30
	MSM031C	13.0	12.20	0.35
-110	MS2N03-B	13.0	12.20	0.45
	MS2N03-D	14.0	12.20	0.45
	MS2N04	14.0	12.20	0.60
	MSM031C	14.0	12.20	0.45
	MSM041B	29.4	42.29	0.65
-145	MS2N04	26.1	42.29	0.80
	MS2N05	26.1	42.29	1.00
	MSM041B	26.1	42.29	0.80
-200	MS2N06	50.0	210.00	1.80
	MS2N07	98.0	390.00	2.25

Diagrams

Permissible drive torque

The values shown for M_p apply under the following conditions:

- ▶ Screw journal without keyway
- ▶ No radial load on screw journal

⚠ Keep in mind the rated torque of the coupling being used! Keep in mind the minimum travel s_{min} !

⚠ Screw journal with keyway

For reasons of stress concentration and a reduction of the effective diameter, observe the maximum values for drive torque!

CKK	M_p (Nm)
-110 / -145	no reduction
-200	48.6

⚠ For Ball Screw Assembly with keyway, the smallest value from the diagrams and table is valid.

Example:

CKK-200	$(d_o \times P)$	
	32 x 32	32 x 10
Length (mm)	1,500	1,500
M_p from diagram (Nm)	58.5	39.0
M_p maximum (Nm)	48.6	48.6
Value for dimensioning	48.6	39.0

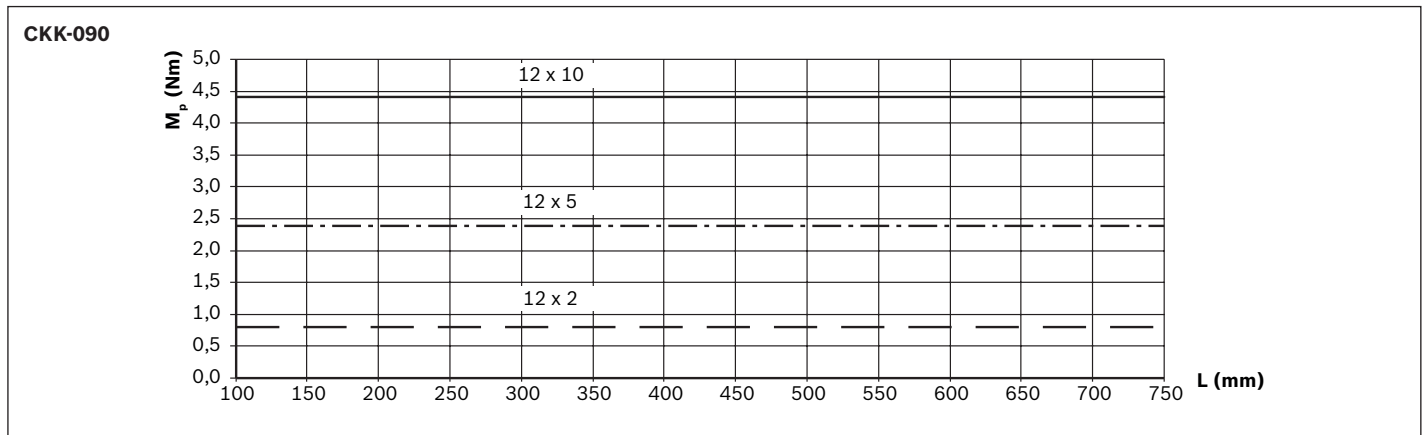
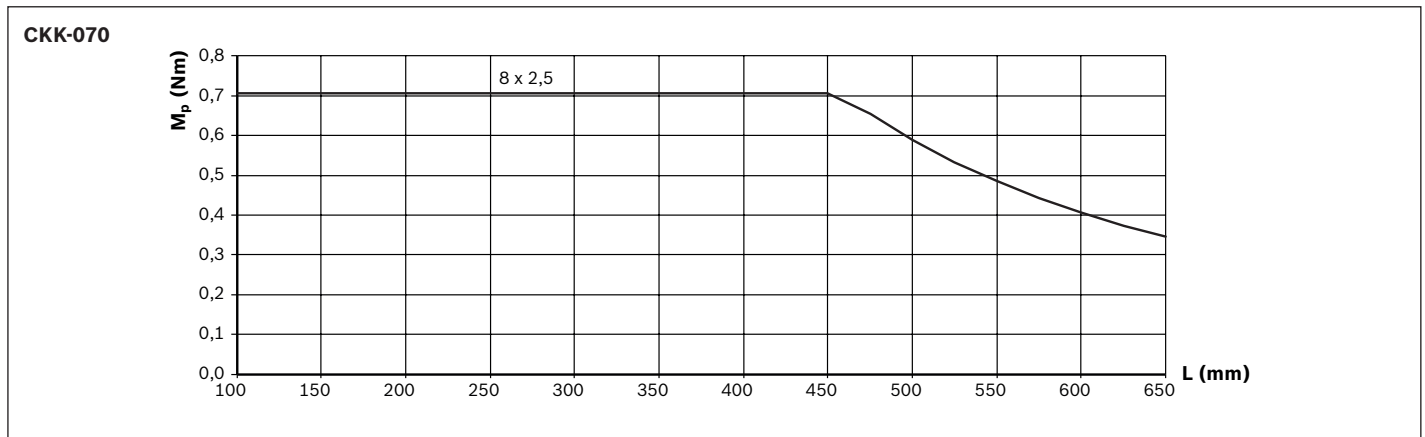

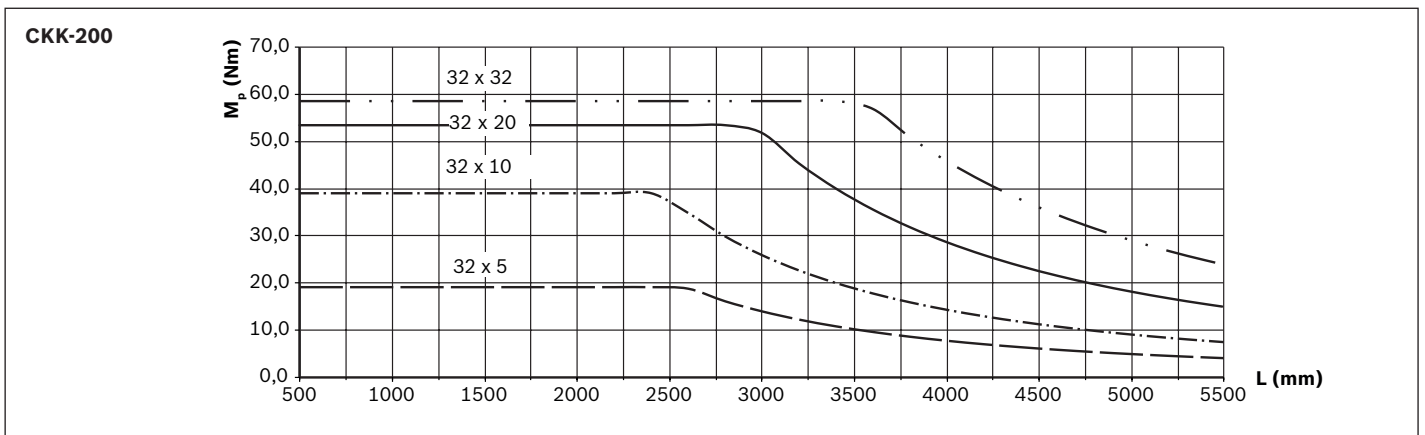
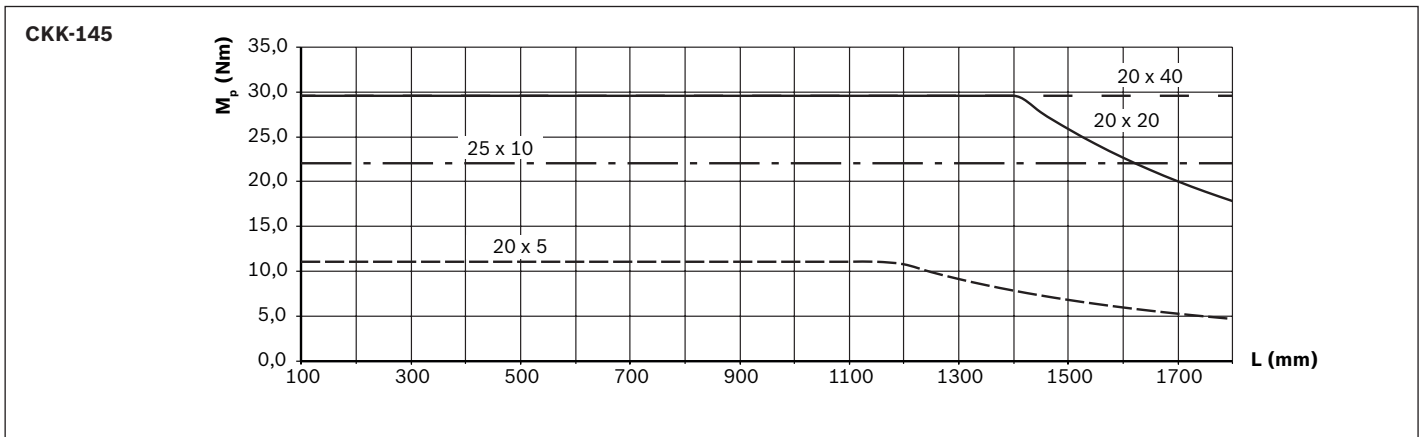
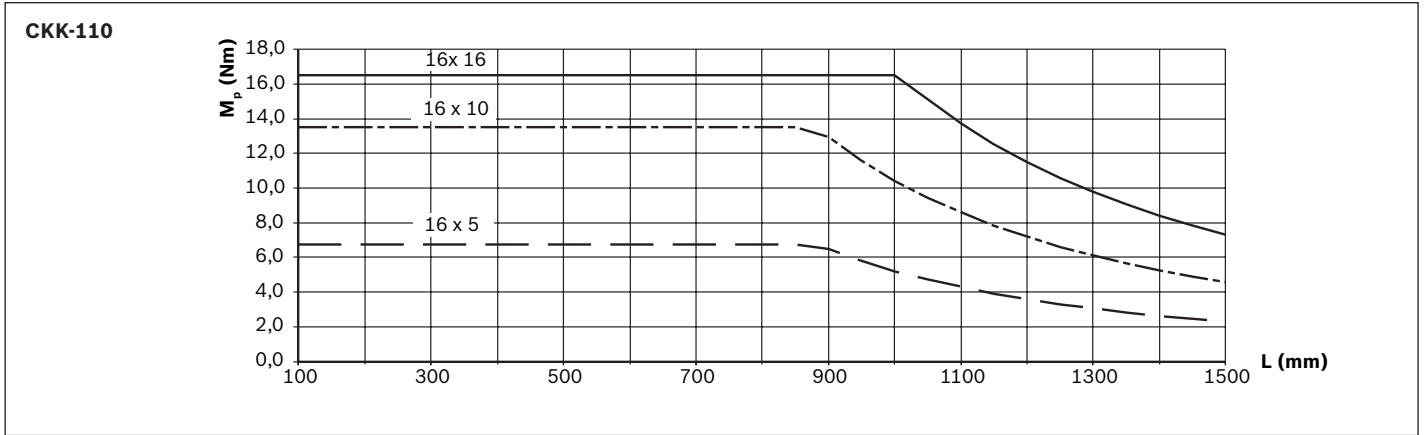

Permissible speed

Observe motor speed!

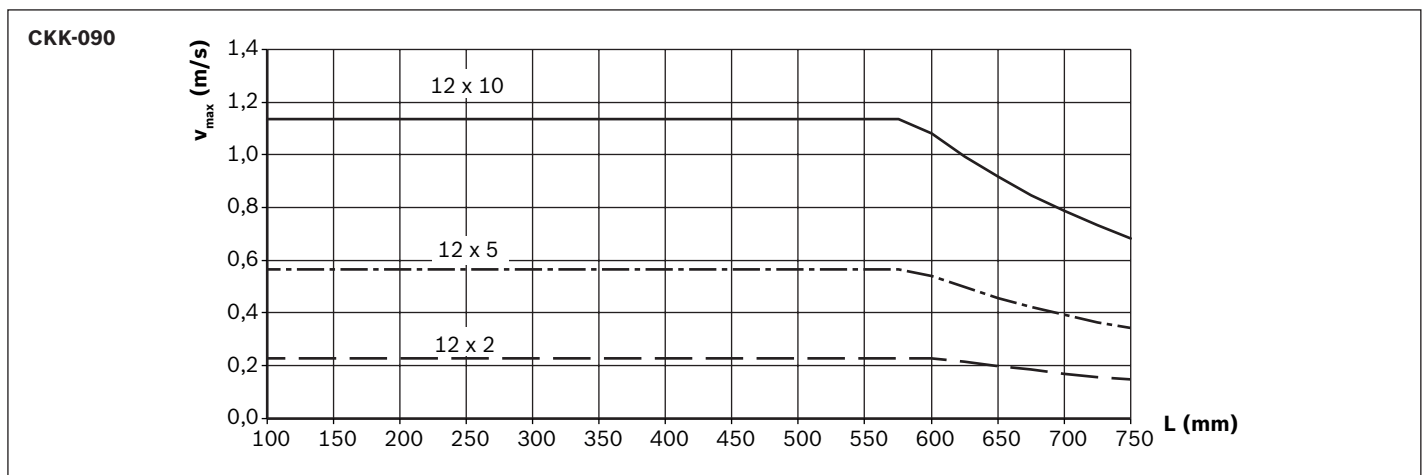
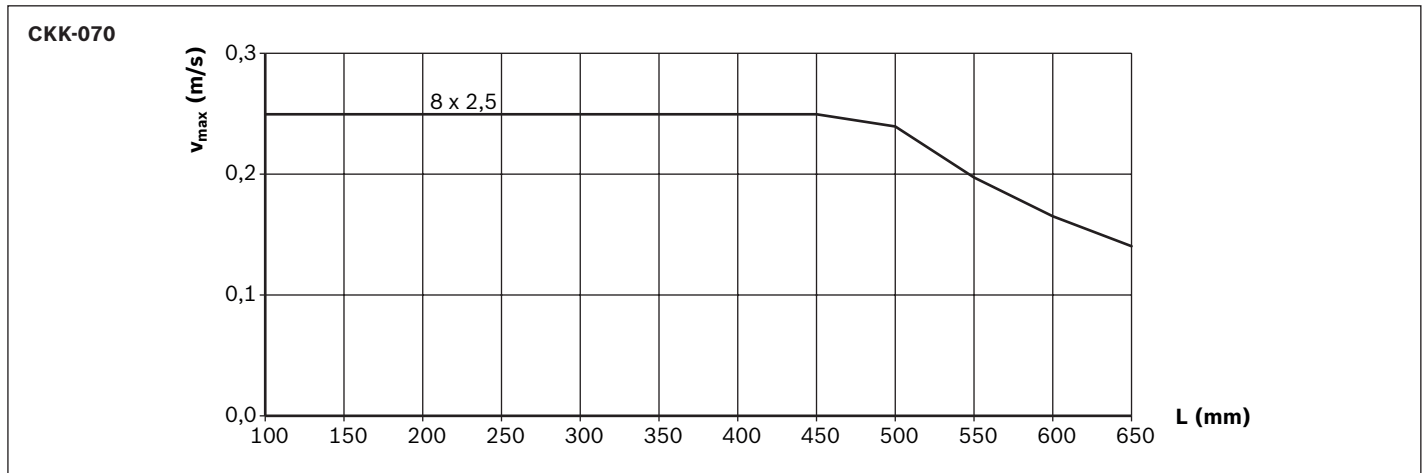

Keep in mind the minimum travel s_{min} !

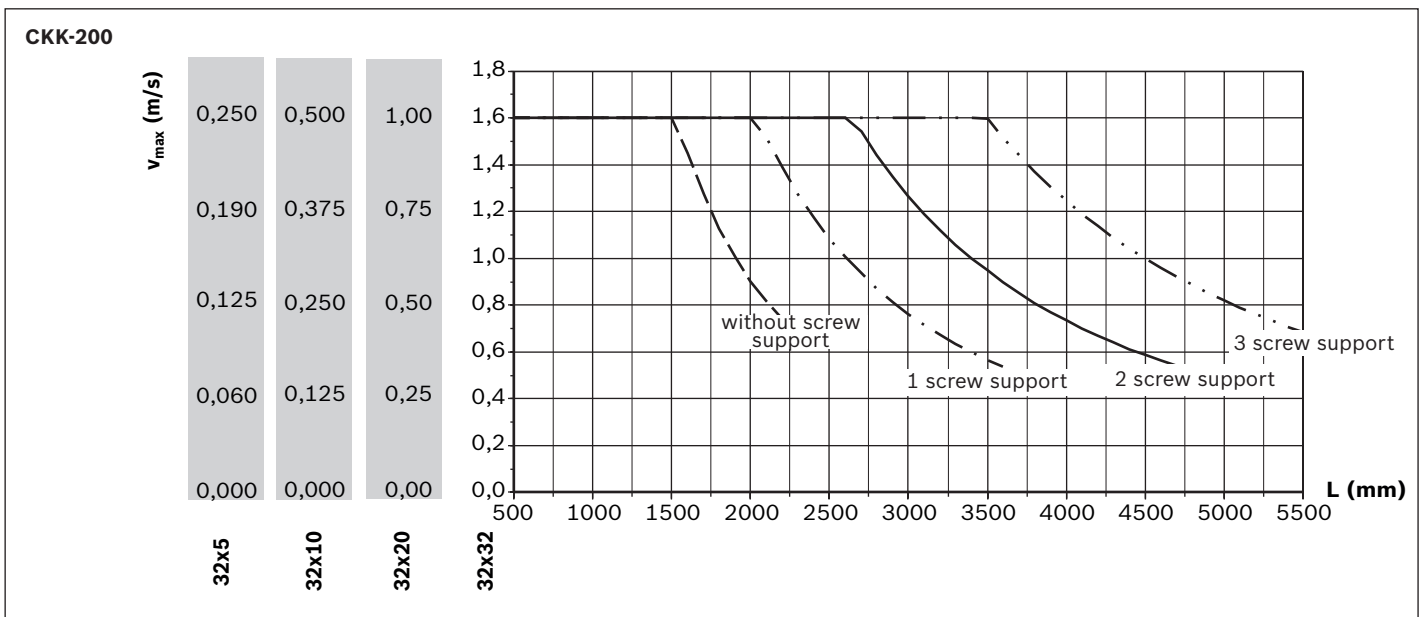
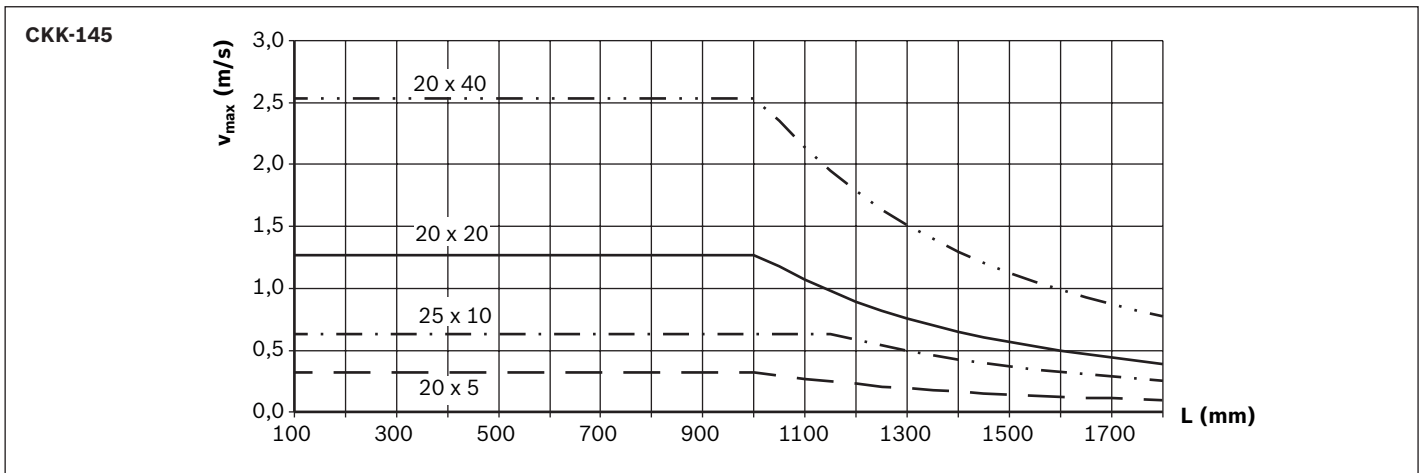
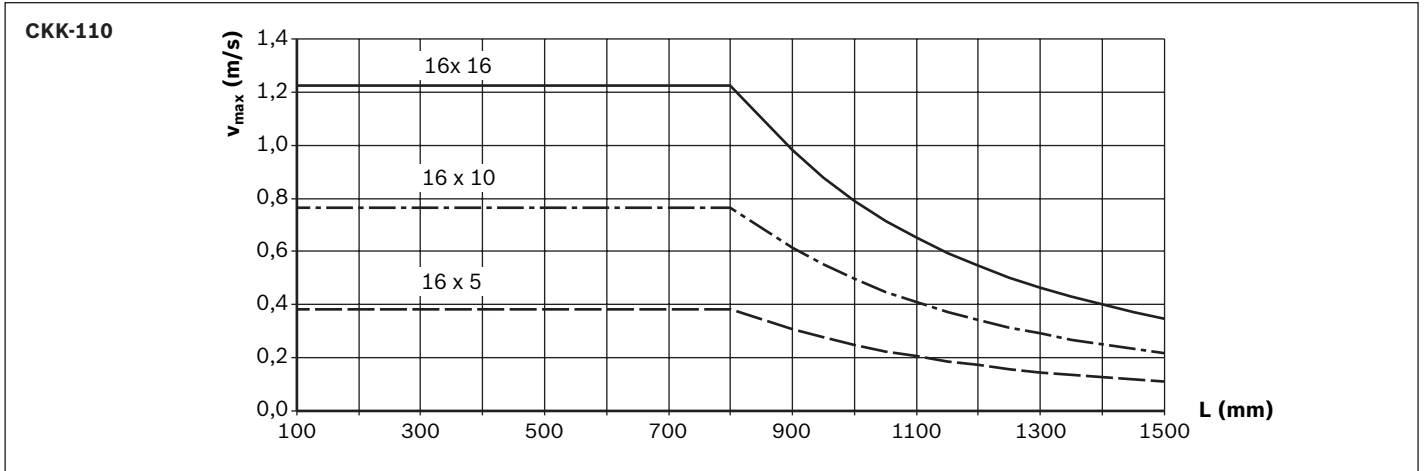





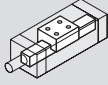

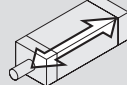
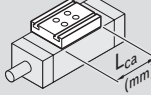
Configuration, order

CKK-070

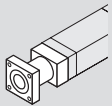
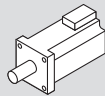
Short product name, length ¹⁾ CKK-070-NN-1, mm		Guideway		Lubrication ³⁾	Drive		Carriage						
													
Version		Standard	Center holes ²⁾		Screw journal (mm)	BASA d ₀ x P (mm)	Connection plate without L _{ca} (mm)		with L _{ca} = (mm)				
						8 x 2.5	32	73	60	95			
without Drive	OA01	01	03	04	LSS	-	050	01	02	40	41		
	LPG				-			302	-	341			
Without Attachment	OF01				LSS	∅6	01	01	02	40	41		
Flange/coupling	MF01				LPG	∅6	31	-	302	-	341		
Belt side drive	RV01												
	RV02												
	RV03												
	RV04												

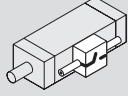
- 1) Length calculation of the linear motion system ⇒ "Project planning/calculation" chapter.
- 2) Center holes for simple combination with other linear motion systems and connection elements (see dimensional drawings).
Option 03: with center holes and fastening threads in the ground area of the frame
Option 04: with center holes and long hole in the ground area of the frame; selectable starting from length L ≥ 300 mm up to length L_{max}
- 3) Lubrication ⇒ "Lubrication" chapter.
- 4) Attachment kit also available without motor. When ordering, enter the motor type "00" ⇒
Mounting kits according to customer specification ⇒ Chapter "Mounting kits for motors according to customer specification"
- 5) Further information ⇒ Chapter "Switching System"
- 6) Recommended motor, motor data and type designations ⇒ "Motors" chapter
- 7) Assembly contains 1 x sensor, 1 x switch mounting plate including set screws and square nuts as well as 3 x cable holders including set screws
- 8) Measurement report: 01 = standard report; 02 = Measurement of frictional torque; 03 = Lead deviation (see also "Documentation" chapter)

Motor attachment		Motor ⁵⁾						Cover		Switching system ⁶⁾		Documentation ⁸⁾	
													
i =	Attachment kit ⁴⁾	Motor code		2 cables		1 cable		Cover strip					
				without brake	with brake	without brake	with brake	without	with				
OA01	-	-	-	-	-	-	-	-	-	Without		01	
OF01	-	-	-	-	-	-	-	-	-	Magnetic sensor			
MF01	-	01	MS2N03-B0BYN	201	202	203	204	000	01	02	- Switch - Mounting channel - Socket-plug		
RV01 - RV04	1	03	MSM031B-0300	136	137	-	-	090	01	02	REED, changeover (NC: C+NC, NO: C+NO)	21	02
		05	MSM019B-0300	134	135	-	-				Hall, PNP normally closed (NC)	22	
		11	MS2N03-B0BYN	201	202	203	204				Hall, PNP normally open (NO)	23	
	13	MSM031B-0300	136	137	-	-	Mounting channel	25					
	15	MSM019B-0300	134	135	-	-	Socket-plug	28					
	1.5	12	MS2N03-B0BYN	201	202	203	204	180			Magnetic sensor with plug ⁷⁾		
14	MSM031B-0300	136	137	-	-	270	REED, changeover (NC: C+NC, NO: C+NO)	58	Hall, PNP normally closed (NC)	59			

Flange	Motor connector position			
	0°	90°	180°	270°
MF01	000	090 ★	180	270

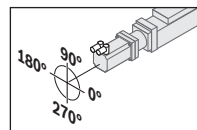

Example:
Flange MF01
Motor connector position 90°

Belt side drive	Motor connector position			
	0°	90°	180°	270°
RV01	000	-	180	270 ★
RV02	000	090 ★	180	-
RV03	000 ★	090	-	270
RV04	-	090	180 ★	270

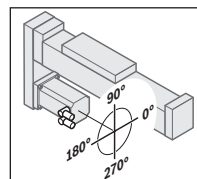

Example:
Belt side drive RV01
Motor connector position 180°





★ standard delivery

Explanation of the order parameters and order example → "Order example" chapter.

CKK-090

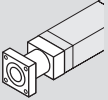
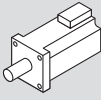
Short product name, length ¹⁾ CKK-090-NN-1, mm		Guideway		Lubrication ³⁾	Drive			Carriage						
		Standard	Center holes ²⁾		Screw journal (mm)	BASA d ₀ x P (mm)			Connection plate without L _{ca} = (mm)			with L _{ca} = (mm)		
Version						12 x 2	12 x 5	12 x 10	35	100	variable ³⁾	60	125	
without drive	OA01	01	03	04	LSS	-			01	02	05	40	41	
					LPG	-			-	302	305	-	341	
Without attachment	OF01				LSS	Ø8	03	01	02	01	02	05	40	41
Flange/coupling	MF01				LPG	Ø8	31	32	33	-	302	305	-	341
Belt side drive	RV01				RV02	LCF	Ø8	03	01	02	-			141
	RV03				RV04	LCO	Ø8	21	22	23	-			241

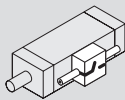
- 1) Length calculation of the linear motion system → "Project planning/calculation" chapter.
- 2) Center holes for simple combination with other linear motion systems and connection elements (see dimensional drawings).
Option 03: with center holes and fastening threads in the ground area of the frame
Option 04: with center holes and long hole in the ground area of the frame; selectable starting from length L ≥ 300 mm up to length L_{max}
- 3) Lubrication → "Lubrication" chapter.
- 4) Attachment kit also available without motor. When ordering, enter the motor type "00" →
Mounting kits according to customer specification → Chapter "Mounting kits for motors according to customer specification"
- 5) Recommended motor, motor data and type designations → "Motors" chapter
- 6) Further information → Chapter "Switching System"
- 7) Assembly contains 1 x sensor, 1 x switch mounting plate including set screws and square nuts as well as 3 x cable holders including set screws
- 8) Measurement report: 01 = standard report; 02 = Measurement of frictional torque; 03 = Lead deviation (see also "Documentation" chapter)

Motor attachment		Motor ⁵⁾						Cover	Switching system ⁶⁾		Documentation ⁸⁾		
													
i =	Attachment kit ⁴⁾	Motor code	2 cables		1 cable		Motor connector position	Cover strip					
			without brake	with brake	without brake	with brake		without	with				
OA01	-	-					-						
OF01	-	-					-						
MF01	-	01	MS2N03-B0BYN	201	202	203	204	000	01	02	Without		
		05	MSM031C-0300	138	139	-	-				- Switch	00	
RV01 - RV04	1	11	MS2N03-B0BYN	201	202	203	204	090	01	02	Magnetic sensor		
		13	MSM031C-0300	138	139	-	-				REED, changeover (NC: C+NC, NO: C+NO)		21
	1.5	21	MS2N03-B0BYN	201	202	203	204	270			Hall, PNP normally closed (NC)	22	
		23	MSM031C-0300	138	139	-	-				Hall, PNP normally open (NO)		23
											02	Mounting channel	25
												Socket-plug	17
												Magnetic sensor with plug ⁷⁾	
												REED, changeover (NC: C+NC, NO: C+NO)	58
												Hall, PNP normally closed (NC)	59

Flange	Motor connector position			
	0°	90°	180°	270°
MF01	000	090 ★	180	270

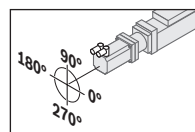

Example:
Flange MF01
Motor connector position 90°

Belt side drive	Motor connector position			
	0°	90°	180°	270°
RV01	000	-	180	270 ★
RV02	000	090 ★	180	-
RV03	000 ★	090	-	270
RV04	-	090	180 ★	270

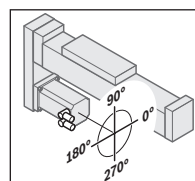

Example:
Belt side drive RV01
Motor connector position 180°

★ standard delivery

Explanation of the order parameters and order example → "Order example" chapter.

CKK-110

Short product name, length ¹⁾ CKK-110-NN-1, mm		Guideway		Lubrication ³⁾	Drive				Carriage						
		Standard	Center holes ²⁾		Screw journal (mm)	BASA d ₀ x P (mm)			Connection plate without L _{ca} = (mm)			with L _{ca} = (mm)			
Version						16 x 5	16 x 10	16 x 16	39	124	variable ³⁾	60	155		
without drive	OA01	01	03	04	LSS	-	050			01	02	05	40	41	
					LPG	-				-	302	305	-	341	
Without attachment	OF01				LSS	Ø11 with Keyway OF01	11	12	13	01	02	05	40	41	
Flange/coupling	MF01				LSS	Ø11	01	02	03	01	02	05	40	41	
					LPG	Ø11	31	32	33	-	302	305	-	341	
Belt side drive	RV01				LCF	Ø11	01	02	03						141
	RV02														
	RV03				LCO	Ø11	01	02	03						241
	RV04														

- 1) Length calculation of the linear motion system → "Project planning/calculation" chapter.
- 2) Center holes for simple combination with other linear motion systems and connection elements (⇒ Dimensional drawings).
Option 03: with center holes and fastening threads in the ground area of the frame
Option 04: with center holes and long hole in the ground area of the frame; selectable starting from length L ≥ 300 mm up to length L_{max}
- 3) Lubrication → "Lubrication" chapter.
- 4) Attachment kit also available without motor. When ordering, enter the motor type "00"⇒
Mounting kits according to customer specification → Chapter "Mounting kits for motors according to customer specification"
- 5) Recommended motor, motor data and type designations → "Motors" chapter
- 6) Only possible with version Carriage with connection plate L_{ca} = 155 mm;
Switch mounting only possible with magnetic sensor with plug. (It may be necessary to move the mounting clamps for Resist cover)
- 7) Further information → Chapter "Switching System"
- 8) Assembly contains 1 x sensor, 1 x switch mounting plate including set screws and square nuts as well as 3 x cable holders including set screws
- 9) Measurement report: 01 = Standard report; 02 = Measurement of frictional torque; 03 = Lead deviation (⇒ "Documentation" chapter)

Motor attachment		Motor ⁵⁾						Cover			Switching system ⁷⁾		Documentation ⁹⁾				
i =	Attachment kit ⁴⁾	Motor code	2 cables		1 cable		Motor connector position	Cover strip		Resist ⁶⁾							
			without brake	with brake	without brake	with brake		without	with								
OA01	-	-	-	-	-	-	-	-	-	-	Without		01				
OF01	-	-	-	-	-	-	-	-	-	-	- Switch - Mounting channel - Socket-plug						
MF01	-	01	MS2N03-B0BYN	201	202	203	204	000	01	02	12	Magnetic sensor		02			
		07	MS2N03-D0BYN	205	206	207	208					REED, changeover (NC: C+NC, NO: C+NO)	21				
		03	MS2N04-C0BTN	213	214	215	216					Hall, PNP normally closed (NC)	22				
			MS2N04-D0BQN	217	218	219	220					Hall, PNP normally open (NO)	23				
		05	MSM031C-0300	138	139	-	-					Mounting channel	25				
		06	MSM041B-0300	140	141	-	-					Socket-plug	17				
RV01 - RV04	1	11	MS2N03-B0BYN	201	202	203	204	090	01	02	12	Magnetic sensor with plug ⁸⁾		03			
		13	MS2N04-C0BTN	213	214	215	216					REED, changeover (NC: C+NC, NO: C+NO)	58				
		15	MSM031C-0300	138	139	-	-					180	Hall, PNP normally closed (NC)		59		
		17	MSM041B-0300	140	141	-	-					270					
	1.5	21	MS2N03-B0BYN	201	202	203	204	270				01	02		12		
		23	MS2N04-B0BTN	209	210	211	212										
		25	MSM031C-0300	138	139	-	-										
		27	MSM041B-0300	140	141	-	-										

Flange	Motor connector position			
	0°	90°	180°	270°
MF01	000	090 ★	180	270

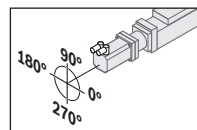

Example:
Flange MF01
Motor connector position 90°

Belt side drive	Motor connector position			
	0°	90°	180°	270°
RV01	000	-	180	270 ★
RV02	000	090 ★	180	-
RV03	000 ★	090	-	270
RV04	-	090	180 ★	270

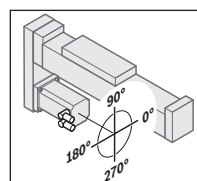

Example:
Belt side drive RV01
Motor connector position 180°



★ standard delivery

Explanation of the order parameters and order example ⇒ "Order example" chapter.

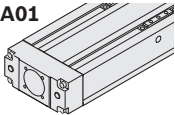
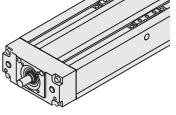
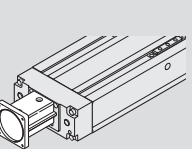
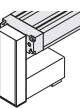
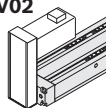
CKK-145

Short product name, length ¹⁾ CKK-145-NN-1, mm		Guideway		Lubrication ³⁾	Drive				Carriage						
		Standard	Center holes ²⁾		Screw journal (mm)	BASA d ₀ x P (mm)				Connection plate without L _{ca} = (mm)			with L _{ca} = (mm)		
Version						20 x 5	20 x 20	25 x 10	20 x 40	49	149	variable ¹⁾	80	190	
Without drive		01	03	04	LSS	-				01	02	05	40	41	
					LPG	-				-	302	305	-	341	
Without attachment		01	03	04	LSS	Ø14 with Keyway (OF01)	14	15	16	-	01	02	05	40	41
							-	17	06	07	10	08	09		
Flange/coupling		01	03	04	LSS	Ø14	21	22	23	-	01	02	05	40	41
							-	24	06	07	10	08	09		
Belt side drive	 	01	03	04	LPG	Ø14	31	32	33	-	-	302	305	-	341
							-	34	-	307	310	-	309		
	LCF				Ø14	21	22	23	-	-					141
						-			24	-					109
	LCO				Ø14	21	22	23	-	-					241
						-			24	-					209

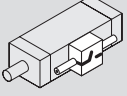
- 1) Length calculation of the linear motion system ⇒ "Project planning/calculation" chapter.
- 2) Center holes for simple combination with other linear motion systems and connection elements (⇒ Dimensional drawings).
Option 03: with center holes and fastening threads in the ground area of the frame
Option 04: with center holes and long hole in the ground area of the frame; selectable starting from length L ≥ 300 mm up to length L_{max}
- 3) Lubrication ⇒ "Lubrication" chapter.
- 4) Attachment kit also available without motor. When ordering, enter the motor type "00"⇒
Mounting kits according to customer specification ⇒ Chapter "Mounting kits for motors according to customer specification"
- 5) Recommended motor, motor data and type designations ⇒ "Motors" chapter
- 6) Only possible with version Carriage with connection plate L_{ca} = 190 mm;
Switch mounting only possible with magnetic sensor with plug. (It may be necessary to move the mounting clamps for Resist cover)
- 7) Further information ⇒ Chapter "Switching System"
- 8) Assembly contains 1 x sensor, 1 x switch mounting plate including set screws and square nuts as well as 3 x cable holders including set screws
- 9) Measurement report: 01 = Standard report; 02 = Measurement of frictional torque; 03 = Lead deviation (⇒ "Documentation" chapter)

Motor attachment		Motor ⁵⁾						Cover			Switching system ⁷⁾		Documentation ⁹⁾	
i =	Attachment kit ⁴⁾	Motor code				Motor connector position	Cover strip		Resist ⁶⁾					
		2 cables		1 cable			without	with						
		without brake	with brake	without brake	with brake									
OA01	-	-	-	-	-	-	-	-	-	-	-	-	01	
OF01	-	-	-	-	-	-	-	-	-	-	-	-		
MF01	-	30	MS2N04-C0BTN	213	214	215	216	000	01	02	12	Without		02
			MS2N04-D0BQN	217	218	219	220					- Switch - Mounting channel - Socket-plug	00	
			MS2N05-B0BTN	221	222	223	224					Magnetic sensor		
			MS2N05-C0BTN	225	226	227	228					REED, changeover (NC: C+NC, NO: C+NO)	21	
			MS2N05-D0BRN	229	230	231	232					Hall, PNP normally closed (NC)	22	
RV01 - RV04	1	11	MS2N04-C0BTN	213	214	215	216	090	01	02	12	Hall, PNP normally open (NO)	23	03
			MS2N04-D0BQN	217	218	219	220					Mounting channel	25	
			MSM041B-0300	140	141	-	-					Socket-plug	17	
	1.5	21	MS2N04-B0BTN	209	210	211	212					Magnetic sensor with plug ⁸⁾		
			MS2N04-C0BTN	213	214	215	216					REED, changeover (NC: C+NC, NO: C+NO)	58	
			MS2N04-D0BQN	217	218	219	220					Hall, PNP normally closed (NC)	59	
			MSM041B-0300	140	141	-	-							
2	36	MS2N05-B0BTN	221	222	223	224	180							

Flange	Motor connector position			
	0°	90°	180°	270°
MF01	000	090 ★	180	270

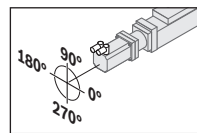

Example:
Flange MF01
Motor connector position 90°

Belt side drive	Motor connector position			
	0°	90°	180°	270°
RV01	000	-	180	270 ★
RV02	000	090 ★	180	-
RV03	000 ★	090	-	270
RV04	-	090	180 ★	270

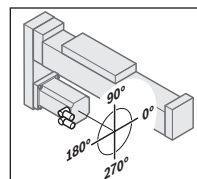

Example:
Belt side drive RV01
Motor connector position 180°

★ standard delivery

Explanation of the order parameters and order example ➔ "Order example" chapter.

CKK-200

Short product name, length ¹⁾ CKK-200-NN-1, mm		Guideway		Lubrication ³⁾	Drive				Carriage								
		Standard	Center holes ²⁾		Screw journal (mm)	BASA d ₀ x P (mm)				Screw support Quantity	Connection plate without			with			
32 x 5	32 x 10			32 x 20		32 x 32	L _{ca} = (mm)				L _{ca} = (mm)						
Version									79.5	254.5	variable ³⁾	190	305				
Without drive	OA01	01	03	04	LSS	-	050				-	01	11	18	40	41	
					LPG	-	050				-	-	311	318	-	341	
Without attachment	OF01	01	03	04	LSS	Ø16 with Keyway	11	12	13	14	0	01	11	18	40	41	
											1	02	12	-	-	26	
											2	03	13	-	-	27	
Flange/coupling	MF01	01	03	04	LSS	Ø16	01	02	03	04	3	04	14	-	-	28	
											0	-	311	318	-	341	
											1	-	312	-	-	326	
Belt side drive	RV01	01	03	04	LPG	Ø16	31	32	33	34	2	-	313	-	-	327	
											3	-	314	-	-	328	
											0	-	-	-	-	141	
	RV02	01	03	04	LCF	Ø16	01	02	03	04	1	-	-	-	-	126	
											2	-	-	-	-	127	
											3	-	-	-	-	128	
	RV03	RV04	01	03	04	LCO	Ø16	01	02	03	04	0	-	-	-	-	241
												1	-	-	-	-	226
												2	-	-	-	-	227
												3	-	-	-	-	228

- 1) Length calculation of the linear motion system ⇒ "Project planning/calculation" chapter.
- 2) Center holes for simple combination with other linear motion systems and connection elements (⇒ Dimensional drawings).
Option 03: with center holes and fastening threads in the ground area of the frame; selectable up to length L ≤ 2000mm
Option 04: with center holes and long hole in the ground area of the frame; selectable starting from length L ≥ 300 mm up to length L_{max}
- 3) Lubrication ⇒ "Lubrication" chapter.
- 4) Attachment kit also available without motor. When ordering, enter the motor type "00"⇒
Mounting kits according to customer specification ⇒ Chapter "Mounting kits for motors according to customer specification"
- 5) Recommended motor, motor data and type designations ⇒ "Motors" chapter
- 6) Only possible with version Carriage with connection plate L_{ca} = 305 mm;
Switch mounting only possible with magnetic sensor with plug. (It may be necessary to move the mounting clamps for Resist cover)
- 7) Further information ⇒ Chapter "Switching System"
- 8) Assembly contains 1 x sensor, 1 x switch mounting plate including set screws and square nuts as well as 3 x cable holders including set screws
- 9) Switch configuration with magnetic sensor and mechanical/proximity switch together on one side is not possible.
Assembly contains 1 x sensor, 1 x switch mounting plate including mounting material
- 10) Switching angle can be attached only in conjunction with connection plate
- 11) Measurement report: 01 = Standard report; 02 = Measurement of frictional torque; 03 = Lead deviation (⇒ "Documentation" chapter)

Motor attachment		Motor				Cover		Switching system ⁷⁾		Documentation ¹¹⁾
i =	Attachment kit ⁴⁾	Motor code				Motor connector position	Cover strip		Resist ⁶⁾	
		2 cables		1 cable			without	with		
		without brake	with brake	without brake	with brake					
OA01	-	-	-	-	-	-	-	-	Without	01
OF01	-	-	-	-	-	-	-	-	- Switch - Mounting channel - Socket-plug	
MF01	-	03	MS2N06-D0BRN	241	242	243	244	000	Magnetic sensor	00
			MS2N06-E0BRN	249	250	251	252		REED, changeover (NC: C+NC, NO: C+NO)	
	04	MS2N07-C0BQN	257	258	259	260	Hall, PNP normally closed (NC)		22	
		MS2N07-D0BRN	265	266	-	-	Hall, PNP normally open (NO)		23	
RV01 - RV04	1	27	MS2N06-B1BNN	233	234	235	236	090	Mounting channel	25
			MS2N06-D1BNN	245	246	247	248	180	Socket-plug	17
	2	28	MS2N06-C0BTN	237	238	239	240	270	Magnetic sensor with plug ⁸⁾	02
									REED, changeover (NC: C+NC, NO: C+NO)	
									Hall, PNP normally closed (NC)	59
									Proximity/mechanical switches ⁹⁾	03
								Mechanical	15	
								Proximity - PNP NC contact	11	
								Proximity - PNP NO contact	13	
								Cable duct	20	
								Switching angle ¹⁰⁾	1	16
									2	26
								Socket-plug	17	

Flange	Motor connector position			
	0°	90°	180°	270°
MF01	000	090 ★	180	270

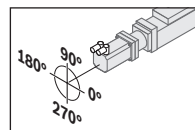

Example:
 Flange MF01
 Motor connector position 90°

Belt side drive	Motor connector position			
	0°	90°	180°	270°
RV01	000	-	180	270 ★
RV02	000	090 ★	180	-
RV03	000 ★	090	-	270
RV04	-	090	180 ★	270

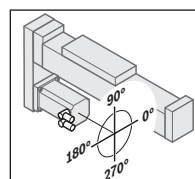

Example:
 Belt side drive RV01
 Motor connector position 180°

★ standard delivery

Explanation of the order parameters and order example ⇒ "Order example" chapter.

Frame CKK-070/-090/-110/-145

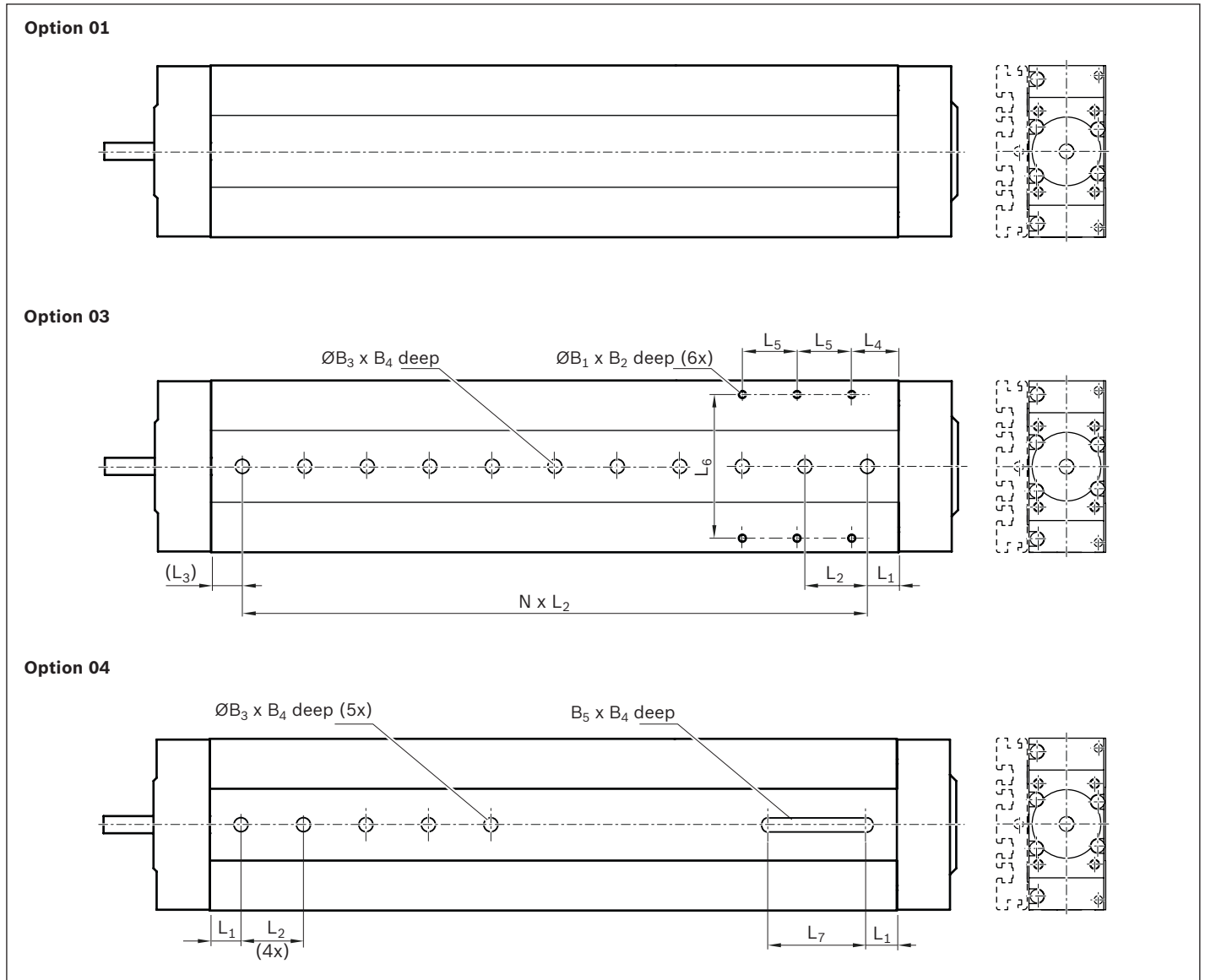

CKK	Option	Dimensions (mm)					L_1	$L_2 \pm 0.01$	L_3 (min)	L_4	L_5	L_6	L_7	
		B_1	B_2	$\varnothing B_3^{H7}$	B_4	B_5^{H8}								
-070	03	M3	6	7	1.6	20	40	10	15	25	59	-		
	04	-	-	-	-			7	-	-	-	-	60	-
-090	03	M4	7.5	9	2.1			-	-	10	30	35	76	-
	04	-	-	-	-			9	-	-	-	-	-	60
-110	03	M5	9	9	2.1			-	-	10	30	35	92	-
	04	-	-	-	-			9	-	-	-	-	-	60
-145	03	M6	13	12	2.1			-	-	10	30	35	124	-
	04	-	-	-	-			12	-	-	-	-	-	60
-200	03	M8	12	16	3.1			-	-	10	35	40	119	-
	04	-	-	-	-			16	-	-	-	-	-	60

Frame CKK-200

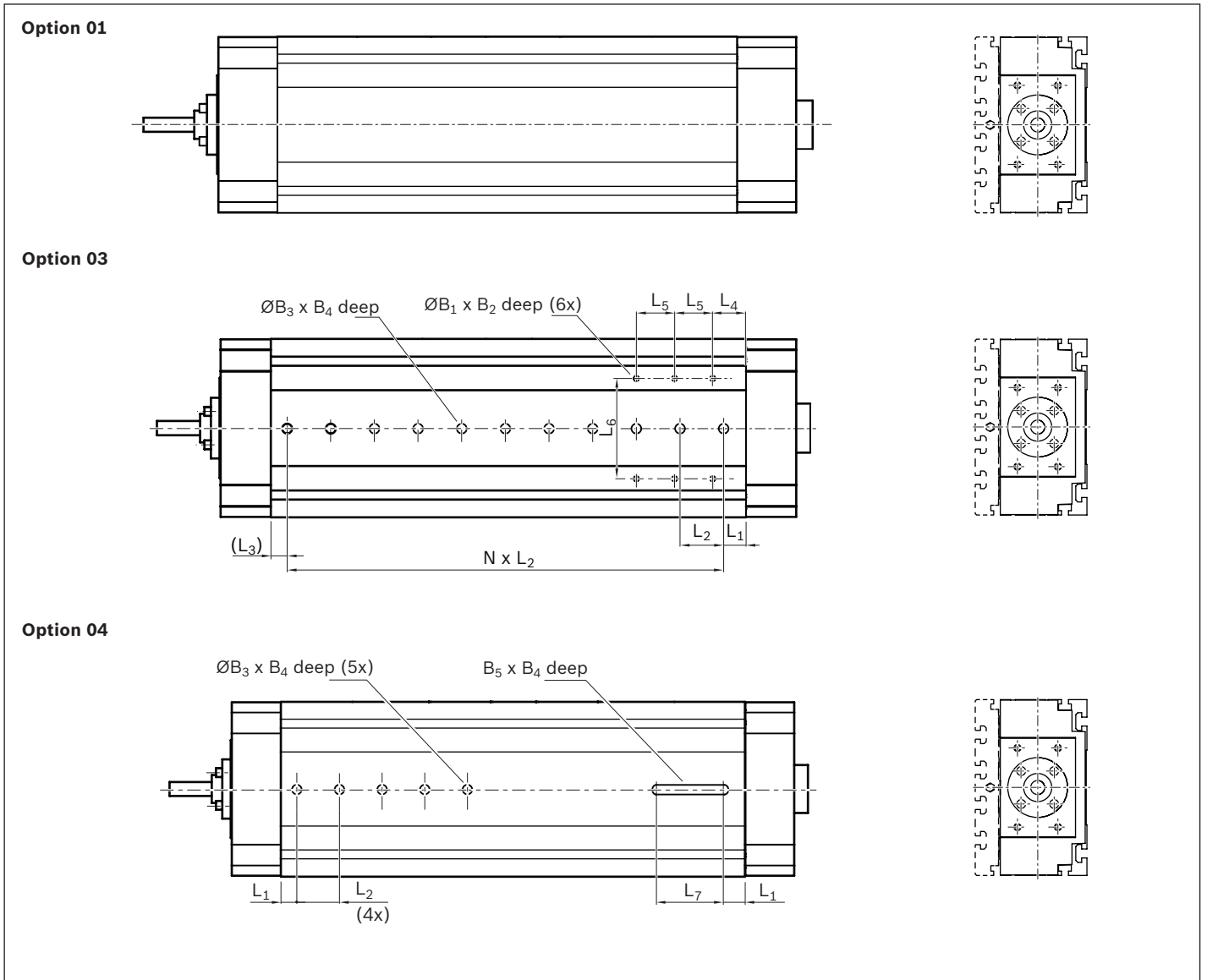

Views from below (ground area)

Option 01 / standard

Option 03 / with central holes

Option 04 / with central holes and long hole

Carriages CKK-070/-090/-110/-145/-200

Carriage without connection plate

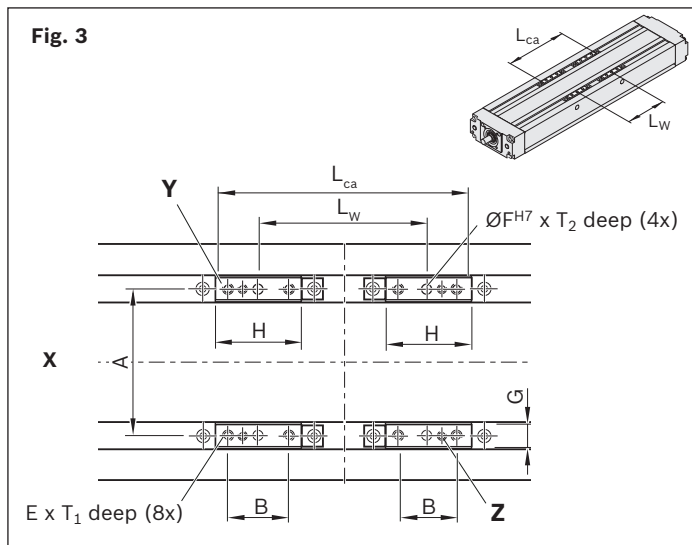
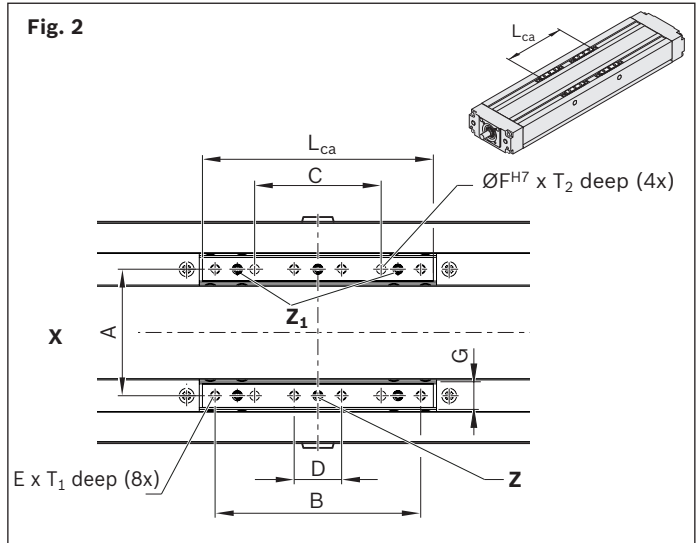
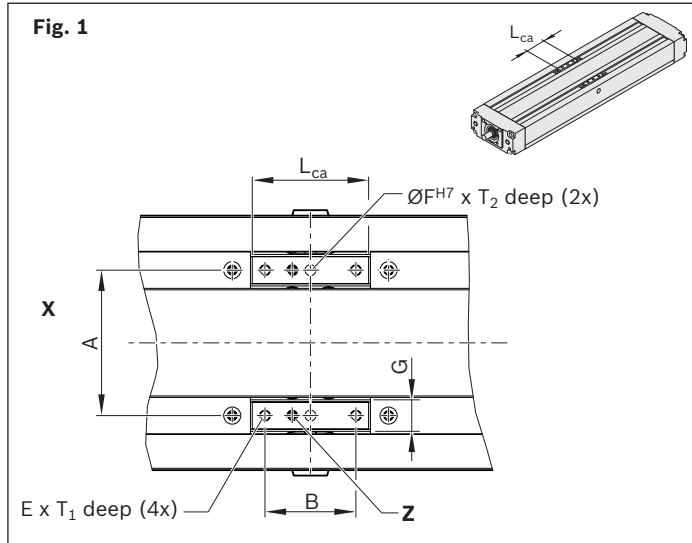

X Drive side
Y Drive carriage
Z/Z₁ Lubrication point for grease; sealed with set screw.
 Supplementary information on the lubrication
 ➔ "Lubrication" chapter.

Carriage with connection plate¹⁾

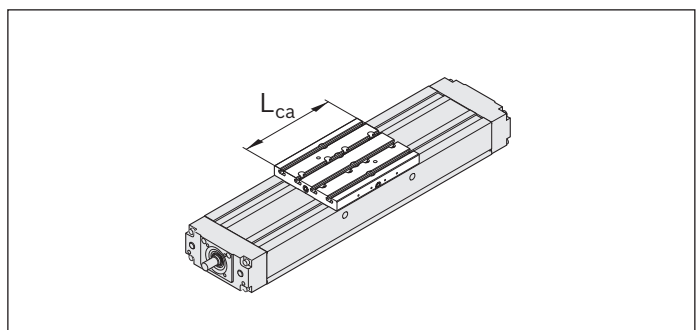
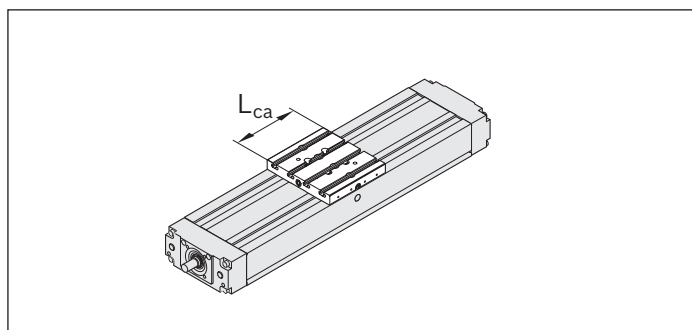

¹⁾ Dimensional drawings ➔ "Connection plates" chapter

CKK	Figure	Dimensions (mm)												
		L _{ca}	L _w	A	B	C	D	E	ØF ^{H7}	G	H	T ₁	T ₂	
-070	1	32	-	40	25	-	-	M3	3	7.5	-	5	5	
	2	73			65	40	15							
-090	1	35	-	54	27	-	-	M4	4	8.0	35	7	6	
	2	100			92	65	38							
	3	variable min. 101 max. 235			min. 66 max. 200	27	-							-
-110	1	39	-	66	30	-	-	M5	5	10.0	39	10	8	
	3	124												85
	3	variable min. 125 max. 289												min. 86 max. 250
-145	1	49	-	88	36	-	-	M6	6	12.0	49	12	10	
	3	149												100
	3	variable min. 150 max. 349												min. 101 max. 300
-200	1	79.5	-	130	60	-	-	M8	8	16.0	79.5	16	12	
	3	254.5												175
	3	variable min. 255.5 max. 429.5												min. 176 max. 350

Motor attachment with flange and coupling

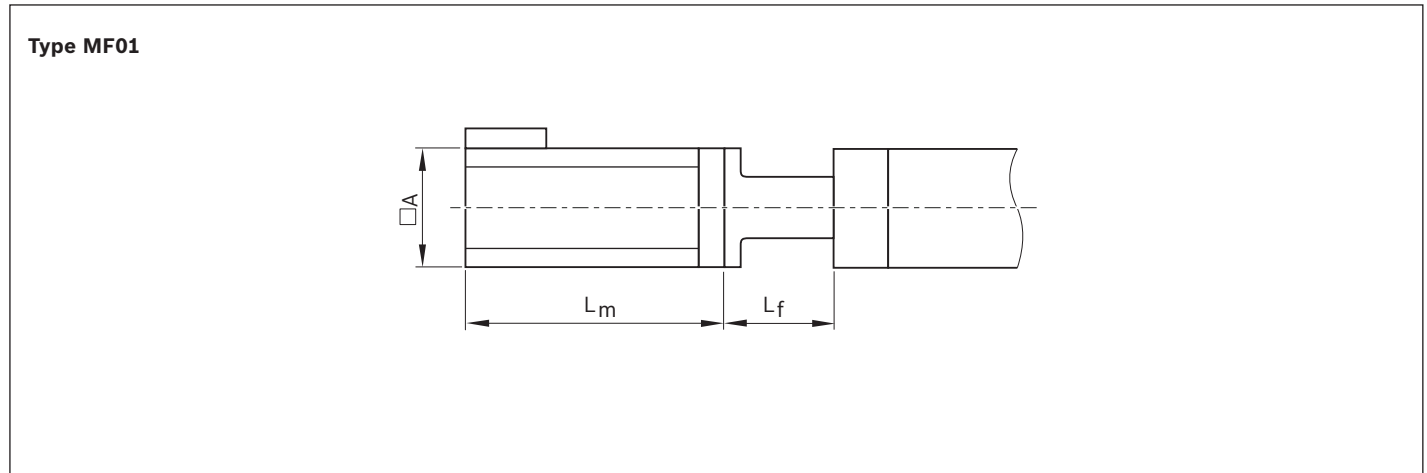

CKK	Motor code	Dimensions (mm)		
		L _f	L _m	□A
-070	MS2N03-B0BYN	50.0		
	MSM031B-0300			
	MSM019B-0300	45.0		
-090	MS2N03-B0BYN	70.0		
	MSM031C-0300	71.5		
-110	MS2N03-B0BYN	75.0		
	MS2N03-D0BYN			
	MS2N04-C0BTN	77.5		
	MS2N04-D0BQN			
	MSM031C-0300	72.0		
	MSM041B-0300	83.0		
-145	MS2N04-C0BTN	85.0	⇒ "Motors" chapter	
	MS2N04-D0BQN			
	MSM041B-0300	90.0		
	MS2N05-B0BTN	95.0		
	MS2N05-C0BTN			
	MS2N05-D0BRN			
-200	MS2N06-D0BRN	125.0		
	MS2N06-E0BRN			
	MS2N07-C0BQN	133.0		
	MS2N07-D0BRN			

Motor attachment with belt side drive

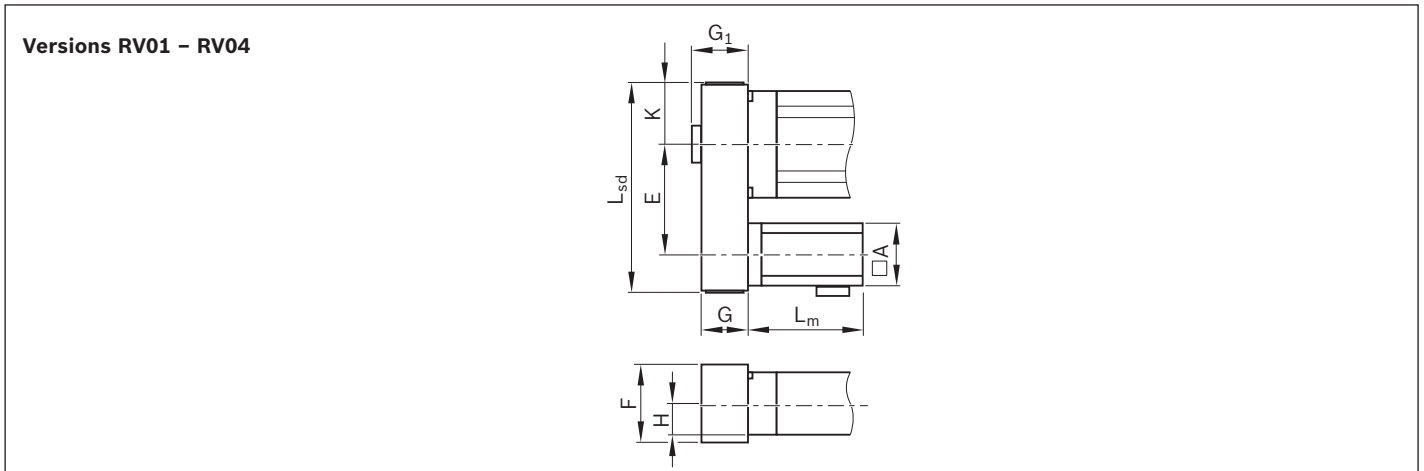

CKK	Motor code	Dimensions (mm)										L _{sd} i= 2	L _m	□A
		i=1	i=1.5	E i=2	F	G	G ₁	H	K	i=1	i=1.5			
-070	MS2N03-B0BYN	78.0	75.0	-	64.5	37.0	43.5	16.0	33.5	154		-		
	MSM031B-0300									157				
	MSM019B-0300	76.5	76.5	-	48.0	27.5	28.0	16.0	27.5	139				
-090	MS2N03-B0BYN	103.5	89.5	-	64.5	37.0	-	21.0	33.0	179	165	-		
	MSM031C-0300													
-110	MS2N03-B0BYN	103.5	115.0	-	64.5	37.0	-	25.5	33.0	179	191	-		
	MS2N04-B0BTN	-	139.5		88.0	51.0		25.5	43.5	-	250			
	MS2N04-C0BTN	145.0	-		88.0	51.0		25.5	43.5	250	-			
	MSM031C-0300	103.5	115.0		64.5	37.0		25.5	33.0	179	191			
	MSM041B-0300	145.0	139.5		88.0	51.0		25.5	43.5	250	250			
-145	MS2N04-B0BTN	-	162.0	-	88.0	51.0	-	34.0	43.5	-	267	-	↑ "Motors" chapter	
	MS2N04-C0BTN	157.5	162.0	-	88.0	51.0	-	34.0	43.5	267	267	-		
	MS2N04-D0BQN													
	MS2N05-B0BTN	165.0	-	162	116.0	66.0	-	34.0	56.0	297	-	297		
	MS2N05-D0BRN	157.5	162.0	-	88.0	51.0	-	34.0	43.5	267	267	-		
	MSM041B-0300													
-200	MS2N06-B1BNN	267.5	-	-	116.0	66.0	-	56.0	59.0	403	-	-		
	MS2N06-D1BNN													
	MS2N06-C0BTN	-	-	265	116.0	66.0	-	56.0	59.0	-	-	403		

Compact Modules with toothed belt drive (CKR)

Product overview

Features

- ▶ Five fine-tuned sizes based on a compact precision aluminum profile with two integrated pre-tensioned Ball Rail Systems
- ▶ Four different lube versions
- ▶ Ready-to-install Compact Modules in any length up to L_{max} .
- ▶ Realization of greater lengths of up to 10,000 mm
- ▶ Pre-tensioned toothed belt
- ▶ Aluminum carriages available in different lengths
- ▶ Intelligent toothed belt guide protects inner components
- ▶ Low-cost maintenance
- ▶ Repeatability of up to ± 0.05 mm

Further highlights

- ▶ Flexible thanks to selectable options
- ▶ Center holes for simple combination with other Linear Motion Systems and connection elements
- ▶ Extensive accessories for connection and clamping elements
- ▶ Nameplate with parameters for easy start-up

Attachments

- ▶ Planetary gearbox with various gear ratios
- ▶ Maintenance-free servo motors with selectable brake and attached feedback
- ▶ Switches (magnetic sensors), switch activation without additional switch flag
- ▶ Socket and plug
- ▶ Mounting duct made of aluminum for sensors

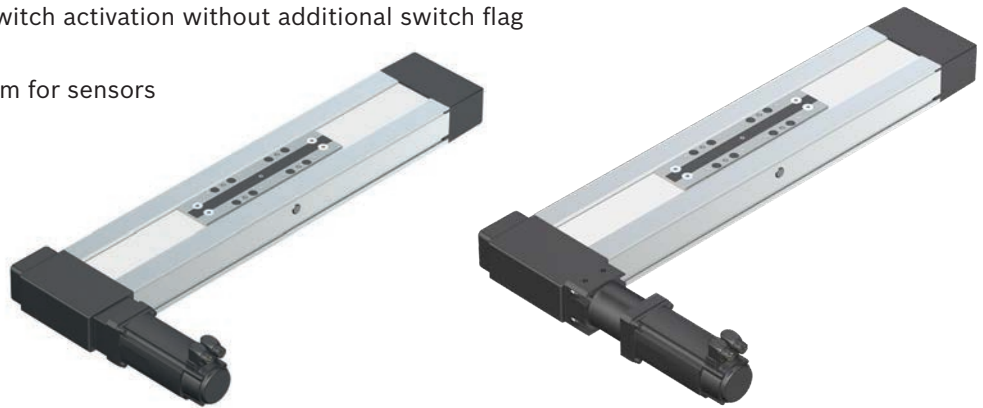

Design/options for guideway (frame), carriages, connection plates

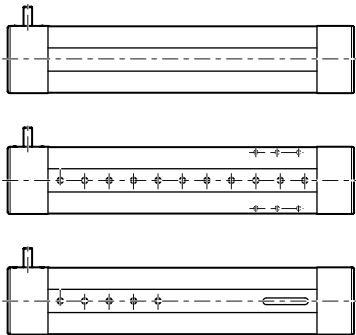

Guideway (frame)

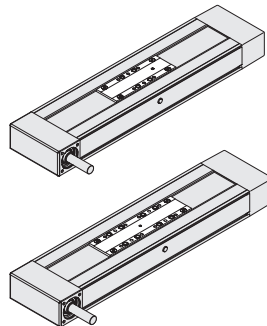

Carriages

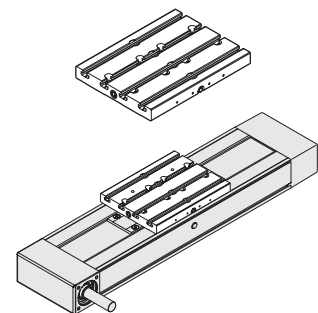

Connection plates

Structural design

Structural design CKR

- 1 Drive end enclosure
- 2 Frame
- 3 Toothed belt drive
- 4 Carriage
- 5 Idler end enclosure

Attachments:

- 6 Magnetic sensor
- 7 Mounting channel
- 8 Socket/plug
- 9 Connection plate
- 10 Flange
- 11 Planetary gearbox
- 12 Motor

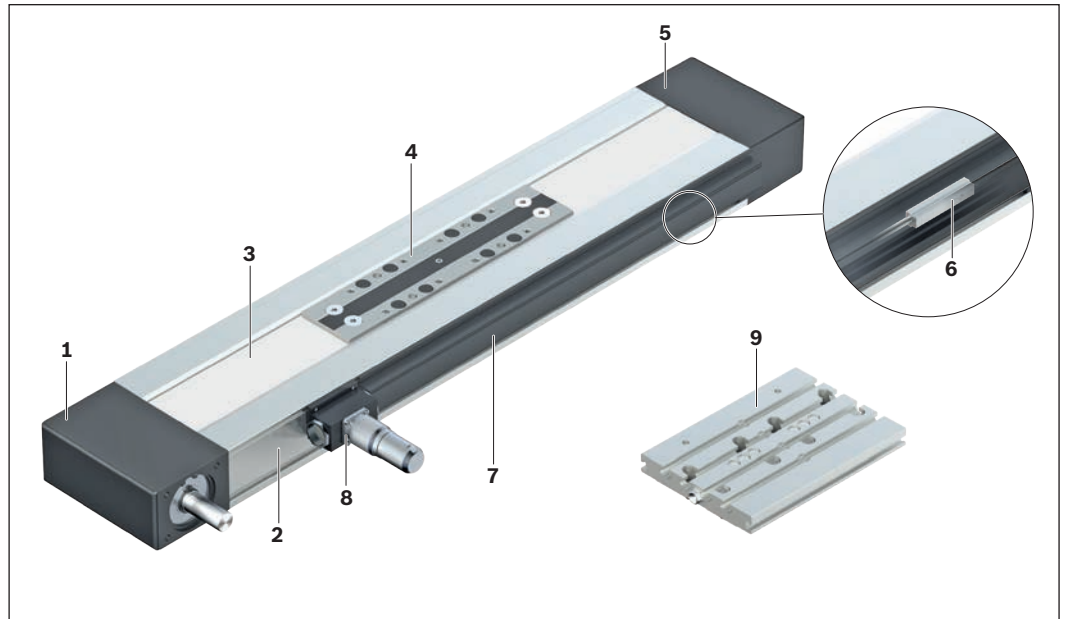

Motor attachment – direct attachment with $i = 1$

The motor is attached directly to the Compact Modules drive end enclosure via a flange.

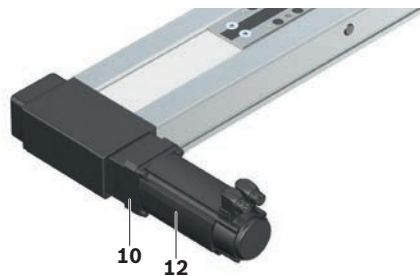

Motor attachment – with gear

The planetary gearbox is attached by means of a flange.

The flange serves to fasten the gearbox to the CRK and as a closed housing. Due to the connection without coupling, the drive torque is transferred to the drive shaft of the Compact Modules in a torsionally stiff manner.

Available gear ratios: $i = 3$ (for CKR-145 and CKR-200)
 $i = 5, i = 10$

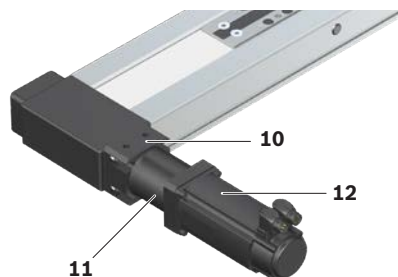

Technical data

General technical data

Observe the "Project planning/calculation" chapter.

CKR	Carriage		Additional length		Min. travel distance	Max. length	Dynamic characteristics		
	Connection plate		Connection plate				Load ratings	Load moments	
	without ¹⁾	with ²⁾	without	with				C_{gw}	M_t
L_{ca}	L_{ca}	L_{ad}	L_{ad}	$s_{min}^{3)}$	L_{max}	(N)	(Nm)	(Nm)	
(mm)	(mm)	(mm)	(mm)	(mm)	(mm)				
-070	80	60	10	30	40	1,500	2,360	47	7
	108	95	10	23			3,830	77	94
-090	102	60	25	67	40	5,500	4,620	125	16
	156	125	25	56			7,505	203	244
-110	170	110	25	85	50	5,500	19,720	651	136
	215	155	25	85			32,035	1,057	1,361
-145	180	125	25	80	60	5,500	46,800	2,059	400
	240	190	25	75			76,025	3,345	3,801
-200	265	190	25	100	80	10,000	74,600	4,849	1,053
	405	305	25	125			121,185	7,877	10,604

Drive data

Observe the "Project planning/calculation" chapter.

CKR	Gearing	Gear ratio	Max. drive torque	Feed constant	Max. speed	Carriage		Moved system mass	
						without	with	without	with
						i	M_P	u	v_{max}
(-)	(Nm)	(mm/rev)	(m/s)	(mm)	(mm)	(kg)	(kg)		
-070	-	1	3.00	72.00	3.00	80	60	0.12	0.23
		5	0.62	14.40	1.92	108	95	0.28	0.45
		10	0.31	7.20	0.96				
-090	-	1	8.00	90.00	3.00	102	60	0.32	0.50
		5	1.65	18.00	3.00	156	125	0.55	0.92
		10	0.82	9.00	1.50				
-110	-	1	13.50	120.00	5.00	170	60	0.52	0.90
		5	2.72	24.00	4.40	215	155	0.87	1.45
		10	1.26	12.00	2.20				
-145	-	1	32.50	165.00	5.00	180	125	0.99	1.80
		3	11.00	55.00	5.00				
		5	6.70	33.00	5.00	240	190	1.67	2.82
		10	3.35	16.50	2.92				
-200	-	1	112.70	250.00	5.00	265	190	2.40	4.60
		3	38.73						
		5	20.62	50.00	5.00				
	PG 090	10	9.28	25.00	2.92	405	305	4.30	7.90
		3	38.73	83.33	5.00				
		5	23.24	50.00	5.00				
		10	11.62	25.00	2.50				

- 1) In the "without connection plate" carriage version, carriage length L_{ca} corresponds to the length of the clamping surface.
- 2) The connection plate is mounted on the "without connection plate" carriage version.
 In the "with connection plate" carriage version, the carriage length corresponds to the length of the connection plate.
- 3) Minimum required travel distance to ensure a reliable lubrication distribution.
- 4) Maximum force that can be transmitted via the teeth meshing with the belt pulley.
- 5) The maximum permitted tensile load on the belt cross section (belt elasticity limit) is given here for easier comparability.
 This value represents the load limit in terms of plastic deformation and may not be used to calculate the maximum permissible drive torque.
- 6) Version with keyway

Maximum permissible loads							Planar moments of inertia		Point of force application	
Moments			Forces				I_y (cm ⁴)	I_z (cm ⁴)	Connection plate	
M_x max (Nm)	M_y max (Nm)	M_z max (Nm)	F_y max (N)	F_{z1} max (N)	F_{z2} max (N)	without Z_1 (mm)			with Z_1 (mm)	
47	7	7	1,270	2,360	2,360	8.50	55.10	20.0	32.5	
77	94	51	2,070	3,830	3,830					
112	16	16	2,490	4,620	4,620	12.80	115.30	24.0	40.0	
203	244	132	4,050	7,505	7,505					
198	32	32	3,480	6,000	6,000	32.70	282.90	28.7	44.7	
396	510	240	5,650	12,000	12,000					
634	100	100	8,410	14,400	14,400	87.50	903.90	37.5	57.5	
1,267	1,440	683	13,660	28,800	28,800					
1,375	299	299	12,265	21,150	21,150	456.60	3,316.60	45.5	72.5	
2,750	3,701	1,744	19,925	42,300	42,300					

Constant mass calculation		Constant mass moment of inertia				Frictional torque M_{Rs} (Nm)	Belt pulley diameter d_3 (mm)	Belt type B_t	Max. belt drive transmission force $F_{bp}^{4)}$ (N)	Belt elasticity limit $F_t perm^{5)}$ (N)	Max. acceleration a_{max} (m/s ²)
k_g fix (kg)	k_g var (kg/mm)	Connection plate		$k_{J var}$ (kgmm)	$k_{J m}$ (mm ²)						
		without $k_{J fix}$ (kgmm ²)	with $k_{J fix}$ (kgmm ²)								
0.50	0.00284	22.32	36.77	0.0142	131.11	0.23	22.92	25 AT3	260	1,100	
		43.14	65.46			0.25					
0.70	0.00440	92.45	129.38	0.0320	205.21	0.57	28.65	35 AT3	560	1,600	
		139.64	215.57			0.58					
1.27	0.00739	266.45	405.08	0.1364	364.81	1.04	38.20	50 AT5	705	4,200	
		391.07	602.66			1.42					
2.54	0.01222	1,024.28	1,582.85	0.3172	689.59	1.46	52.52	70 AT5	1,235	4,800	
		1,621.61	2,276.71			2.04					
7.83	0.02328	6,140.67	9,623.81	1.8397	1,583.24	4.55	79.58	100 AT10	2,830	17,000	
		9,020.05	14,719.73			5.69					

Gear data

Observe the "Project planning/calculation" chapter.

CKR	Gearing Type	Gear ratio <i>i</i> (-)	Max. acceleration torque ¹⁾ (at the gear output)	Base frictional torque	Max. drive speed
			<i>M</i> _{ge} (Nm)	<i>M</i> _{Rge} (Nm)	<i>n</i> _{ge} (min ⁻¹)
-070	PG040	5	11.0	0.05	8,000
		10	10.5	0.05	8,000
-090	PG050	5	14.0	0.09	10,000
		10	13.0	0.08	10,000
-110	PG050	5	14.0	0.09	10,000
		10	13.0	0.08	10,000
-145	PG070	3	32.0	0.24	8,000
		5	40.0	0.17	8,000
		10	35.0	0.12	8,000
-200	PG090	3	125.0	0.38	7,000
		5	100.0	0.26	
		10	90.0	0.17	
	PG120	3	200.0	1.00	6,000
		5	250.0	0.76	
		10	220.0	0.58	

¹⁾ The limits of the linear motion system must not be exceeded ➔ "Drive data / project planning / calculation".



	Motor	Mass moment of inertia		Weight	
			J_{ge} (kgm ²)		m_{ge} (kg)
	MS2N03-B		0.0000041		0.31
	MSM019-B				
	MS2N03-B		0.0000030		0.80
	MSM019-B				
	MS2N03-B		0.0000050		0.80
	MS2N03-D				
	MSM031-C		0.0000130		1.30
	MS2N03-B		0.0000020		0.80
	MS2N03-D				
	MSM031-C		0.0000130		1.30
	MS2N03-B		0.0000030		0.90
	MS2N03-D				
	MS2N04		0.0000130		1.40
	MSM031-C		0.0000130		1.40
	MS2N03-B		0.0000020		0.90
	MS2N03-D				
	MS2N04		0.0000130		1.40
	MSM031-C		0.0000130		1.40
	MS2N04		0.0000320		2.10
	MS2N05				
	MSM041-B		0.0000530		3.20
	MS2N04		0.0000270		2.10
	MS2N05				
	MSM041-B		0.0000460		3.20
	MS2N04		0.0000220		2.10
	MS2N05				
	MSM041-B		0.0000430		3.20
	MS2N06		0.0001800		4.4
			0.0001600		
			0.0001500		
	MS2N07		0.0007200		17.30
			0.0005900		
			0.0005400		

Configuration, order

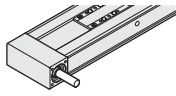
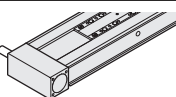
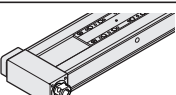
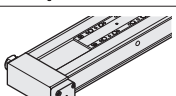
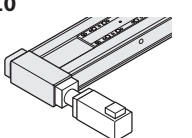
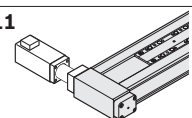
CKR-070

Short product name, length ¹⁾ CKR-070-NN-1, mm		Guideway		Drive		Lubrication ³⁾	Carriage									
		Standard	Center holes ²⁾		without Keyway		for gear unit ⁴⁾	Connection plate without L _{ca} = (mm)		with L _{ca} = (mm)						
Version							80	108	60	95						
Drive journal	MA01 	01	03	04	01	LSS	01	02	40	41						
	MA02 				02											
Clamping hub	MA05 				06						-					
	MA06 				07						-					
Gear attachment	MG10 				-						08	LPG	-	302	-	341
	MG11 				-						09					

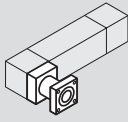
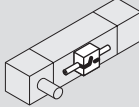
- 1) Length calculation of the linear motion system ⇒ "Project planning/calculation" chapter.
- 2) Center holes for simple combination with other linear motion systems and connection elements (⇒ Dimensional drawings).
Option 03: with center holes and fastening threads in the ground area of the frame.
Option 04: with center holes and fastening threads in the ground area of the frame. Selectable starting from length L ≥ 300 mm up to length L_{max}
- 3) Lubrication ⇒ "Lubrication" chapter.
- 4) Mounting kit for gear attachment
- 5) With servo motor attached, product only available as assembled in the chapter "Form of Delivery" (note position of motor connector).
- 6) Recommended motor, motor data and type designations ⇒ "Motors" chapter
- 7) Further information ⇒ "Switching system" chapter.
- 8) Assembly contains 1 x sensor, 1 x switch mounting plate including set screws and square nuts as well as 3 x cable holders including set screws
- 9) Measurement report: 01 = Standard report; 02 = Measurement of frictional torque; (⇒ "Documentation" chapter)
- 10) Motor attachment consisting of: Adapter flange for gear unit, however "without gear unit". No motor connector position selectable.

Motor attachment ⁵⁾			Motor ⁶⁾					Switching system ⁷⁾		Documentation ⁹⁾		
 Direct drive i = 1			Gearing i = 5 i = 10		Motor code		2 cables without brake with brake		1 cable without brake with brake		Motor connector position	 
MA01 MA02 MA05 MA06	00		00					Without - Switch - Mounting channel - Socket-plug 00		01		
								Magnetic sensor REED, changeover (NC: C+NC, NO: C+NO) 21				
								Hall, PNP normally closed (NC) 22				
								Hall, PNP normally open (NO) 23				
MG10 / MG11	00 ¹⁰⁾		00					Mounting channel 25		02		
								Socket-plug 17				
								Magnetic sensor with plug ⁸⁾ REED, changeover (NC: C+NC, NO: C+NO) 58				
								Hall, PNP normally closed (NC) 59				
		11 12	MS2N03-B0BYN	201	202	203	204	000				
		23 24	MSM019B-0300	134	135	-	-	090				
								180				
								270				

Drive end enclosure with additional drive shaft

In the versions MA05, MA06, MG10 and MG11, a second drive shaft end can be made available by removing the screws and cover.

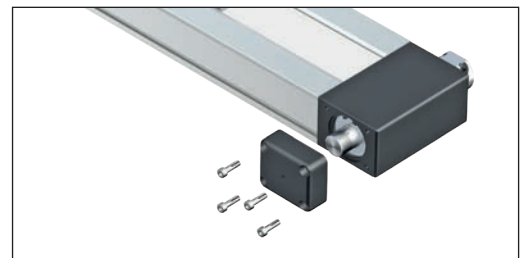

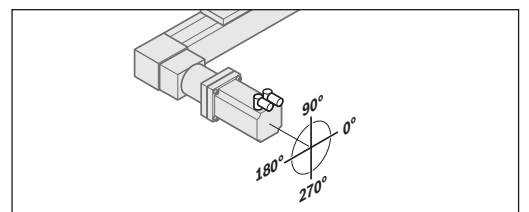

Version	Motor connector position			
	0°	90°	180°	270°
MG10 / MG11	000	090 ★	180	270

★ standard delivery

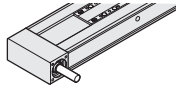

Explanation of the order parameters and order example ➔ "Order example" chapter.

CKR-090

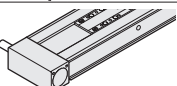
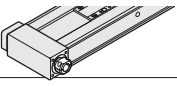
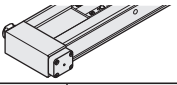
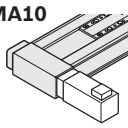
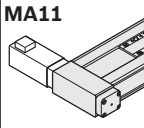
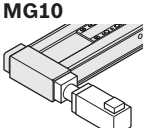
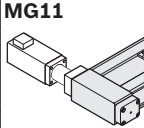
Short product name, length ¹⁾ CKR-090-NN-1, mm		Guideway		Drive			Lubrication ³⁾	Carriage							
		Standard	Center holes ²⁾	without keyway i = 1	with keyway i = 1	for gear unit ⁴⁾		Connection plate without L _{ca} = (mm)		with L _{ca} = (mm)					
Version								102	156	60	125				
Drive journal	MA01 	01	03	04				LSS	01	02	40	41			
	MA02 				01	03									
Clamping hub	MA05 										LPG	-	302	-	341
	MA06 				06	-			-						
Direct attachment	MA10 										LCF				141
	MA11 				06	-			-						
Gear attachment	MG10 										LCO				241
	MG11 				-	-			08						

1) Length calculation of the linear motion system ⇒ "Project planning/calculation" chapter.

2) Center holes for simple combination with other linear motion systems and connection elements (⇒ Dimensional drawings).

Option 03: with center holes and fastening threads in the ground area of the frame. Selectable up to a length of $L \leq 2000$ mm

Option 04: with center holes and fastening threads in the ground area of the frame. Selectable starting from length $L \geq 300$ mm up to length L_{max}

3) Lubrication ⇒ "Lubrication" chapter.

4) Mounting kit for gear attachment

5) With servo motor attached, product only available as assembled in the chapter "Form of Delivery" (note position of motor connector).



6) Recommended motor, motor data and type designations ⇒ "Motors" chapter

7) Further information ⇒ "Switching system" chapter.

8) Assembly contains 1 x sensor, 1 x switch mounting plate including set screws and square nuts as well as 3 x cable holders including set screws

9) Measurement report: 01 = Standard report; 02 = Measurement of frictional torque; (⇒ "Documentation" chapter)

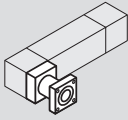
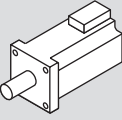
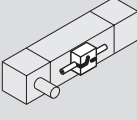
10) Motor attachment consisting of: Adapter flange for gear unit, however "without gear unit". No motor connector position selectable.

Motor attachment ⁵⁾			Motor ⁶⁾					Switching system ⁷⁾		Documentation ⁹⁾
										
Direct drive	Gearing		Motor code	2 cables		1 cable		Motor connector position		
i = 1	i = 5	i = 10		without brake	with brake	without brake	with brake			
MA01	00		00					Without		01
MA02								- Switch	00	
MA05								- Mounting channel		
MA06								- Socket-plug		
MA10 / MA11	01	-	MS2N04-DOBQN	217	218	219	220	Magnetic sensor		
MG10 / MG11	-	00 ¹⁰⁾	00					REED, changeover (NC: C+NC, NO: C+NO)	21	
		15	16	MS2N03-B0BYN	201	202	203	204	Hall, PNP normally closed (NC)	22
		13	14	MS2N03-D0BYN	205	206	207	208	Hall, PNP normally open (NO)	23
		33	34	MSM031C-0300	138	139	-	-	Mounting channel	25
									Socket-plug	17
									Magnetic sensor with plug ⁸⁾	
									REED, changeover (NC: C+NC, NO: C+NO)	58
									Hall, PNP normally closed (NC)	59

Drive end enclosure with additional drive shaft

In the versions MA05, MA06, MA10, MA11, MG10 and MG11, a second drive shaft end can be made available by removing the screws and cover.

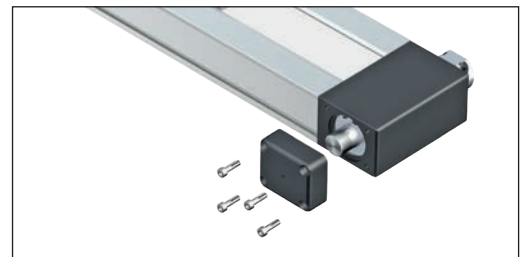

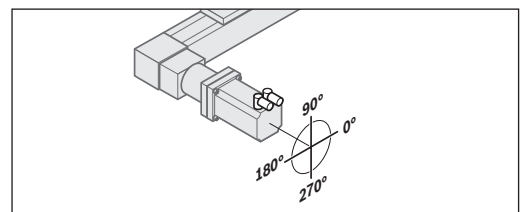

Version	Motor connector position			
	0°	90°	180°	270°
MA10 / MA11 MG10 / MG11	000	090 ★	180	270

★ standard delivery



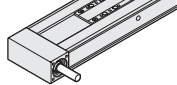
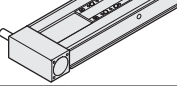
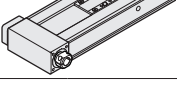
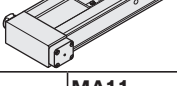
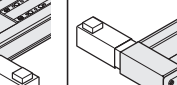
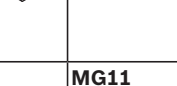
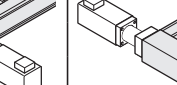

Explanation of the order parameters and order example ➔ "Order example" chapter.

CKR-110

Short product name, length ¹⁾ CKR-110-NN-1, mm		Guideway		Drive			Lubrication ³⁾	Carriage							
		Standard	Center holes ²⁾	without keyway i = 1	with keyway i = 1	for gear unit ⁴⁾		Connection plate without L _{ca} = (mm)	with L _{ca} = (mm)						
Version		01	03	04				170	215	110	155				
Drive journal	MA01 	01	03	04			LSS								
	MA02 				01	03				01	02	40	41		
Clamping hub	MA05 										LPG				
	MA06 				06	-						-	302	-	341
Direct attachment	MA10 										LCF				
	MA11 				06	-		-							
Gear attachment	MG10 										LCO				
	MG11 									08					

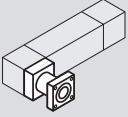
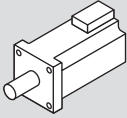
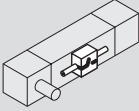
1) Length calculation of the linear motion system ⇒ "Project planning/calculation" chapter.
 2) Center holes for simple combination with other linear motion systems and connection elements (⇒ Dimensional drawings).
 Option 03: with center holes and fastening threads in the ground area of the frame. Selectable up to a length of L ≤ 2000 mm
 Option 04: with center holes and fastening threads in the ground area of the frame. Selectable starting from length L ≥ 300 mm up to length L_{max}
 3) Lubrication ⇒ "Lubrication" chapter.
 4) Mounting kit for gear attachment
 5) With servo motor attached, product only available as assembled in the chapter "Form of Delivery" (note position of motor connector).
 6) Recommended motor, motor data and type designations ⇒ "Motors" chapter
 7) Further information ⇒ "Switching system" chapter.
 8) Assembly contains 1 x sensor, 1 x switch mounting plate including set screws and square nuts as well as 3 x cable holders including set screws
 9) Measurement report: 01 = Standard report; 02 = Measurement of frictional torque; (⇒ "Documentation" chapter)
 10) Motor attachment consisting of: Adapter flange for gear unit, however "without gear unit". No motor connector position selectable.

Motor attachment ⁵⁾			Motor ⁶⁾					Switching system ⁷⁾		Documentation ⁹⁾
										
Direct drive	Gearing		Motor code	2 cables		1 cable		Motor connector position		
	i = 1	i = 5		i = 10	without brake	with brake	without brake			with brake
MA01									01	
MA02	00			00				Without		
MA05								- Switch		00
MA06								- Mounting channel		
								- Socket-plug		
								Magnetic sensor		
								REED, changeover (NC: C+NC, NO: C+NO)	21	
								Hall, PNP normally closed (NC)	22	
MA10 / MA11	01	-	MS2N05-D0BRN	229	230	231	232	Hall, PNP normally open (NO)	23	
								Mounting channel	25	
								Socket-plug	17	
								Magnetic sensor with plug ⁸⁾		
								REED, changeover (NC: C+NC, NO: C+NO)	58	
								Hall, PNP normally closed (NC)	59	
MG10 / MG11	-	00 ¹⁰⁾		00					02	
		15	16	MS2N03-B0BYN	201	202	203	204		
		13	14	MS2N03-D0BYN	205	206	207	208		
		23	24	MS2N04-B0BTN	209	210	211	212		
				MS2N04-C0BTN	213	214	215	216		
		33	34	MSM031C-0300	138	139	-	-		

Drive end enclosure with additional drive shaft

In the versions MA05, MA06, MA10, MA11, MG10 and MG11, a second drive shaft end can be made available by removing the screws and cover.

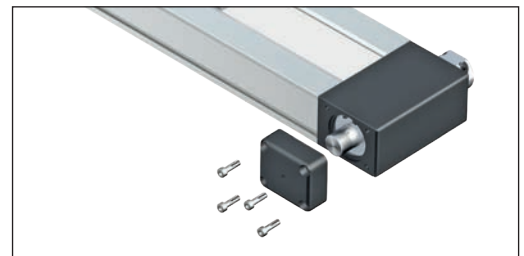

Version	Motor connector position			
	0°	90°	180°	270°
MA10 / MA11 MG10 / MG11	000	090 ★	180	270

★ standard delivery

Explanation of the order parameters and order example ➔ "Order example" chapter.

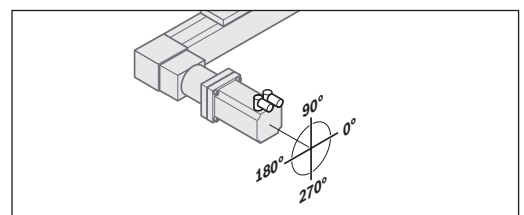

CKR-145

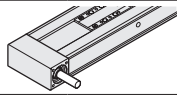
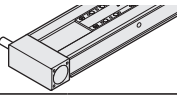
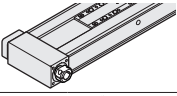
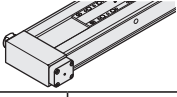
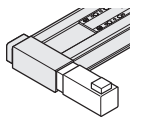
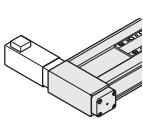
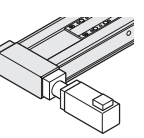
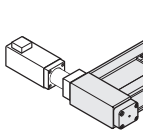
Short product name, length ¹⁾ CKR-145-NN-1, mm		Guideway		Drive			Lubrication ³⁾	Carriage							
		Standard	Center holes ²⁾	without keyway i = 1	with keyway i = 1	for gear unit ⁴⁾		Connection plate without L _{ca} = (mm)	with L _{ca} = (mm)						
Version								180	240	125	190				
Drive journal	MA01 	01	03	04			LSS								
	MA02 				01	03		-	01	02	40	41			
Clamping hub	MA05 										LPG				
	MA06 				06	-		-	-	302		-	341		
Direct attachment	MA10 										LCF				
	MA11 				06	-		-	-	-		141			
Gear attachment	MG10 										LCO				
	MG11 				-	-		08	-	-		241			

1) Length calculation of the linear motion system ⇒ "Project planning/calculation" chapter.

2) Center holes for simple combination with other linear motion systems and connection elements (⇒ Dimensional drawings).

Option 03: with center holes and fastening threads in the ground area of the frame. Selectable up to a length of L ≤ 2000 mm

Option 04: with center holes and fastening threads in the ground area of the frame. Selectable starting from length L ≥ 300 mm up to length L_{max}

3) Lubrication ⇒ "Lubrication" chapter.

4) Mounting kit for gear attachment

5) With servo motor attached, product only available as assembled in the chapter "Form of Delivery" (note position of motor connector).



6) Recommended motor, motor data and type designations ⇒ "Motors" chapter

7) Further information ⇒ "Switching system" chapter.

8) Assembly contains 1 x sensor, 1 x switch mounting plate including set screws and square nuts as well as 3 x cable holders including set screws

9) Measurement report: 01 = Standard report; 02 = Measurement of frictional torque; (⇒ "Documentation" chapter)

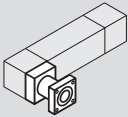
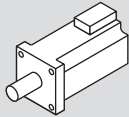
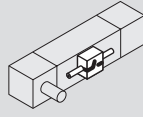
10) Motor attachment consisting of: Adapter flange for gear unit, however "without gear unit". No motor connector position selectable.

Motor attachment ⁵⁾				Motor ⁶⁾				Switching system ⁷⁾		Documentation ⁹⁾		
 Direct drive i = 1 Gearing i = 3 i = 5 i = 10				 Motor code 2 cables without brake with brake 1 cable without brake with brake Motor connector position								
MA01	00			00				Without		01		
MA02	00			00				- Switch				
MA05	00			00				- Mounting channel				
MA06	00			00				- Socket-plug				
MA10 / MA11	01	-	-	MS2N06-D1BNN	245	246	247	248	Magnetic sensor			
MG10 / MG11	-	00 ¹⁰⁾		00				REED, changeover (NC: C+NC, NO: C+NO)				
		13	14	15	MS2N04-C0BTN	213	214	215	216	21		
					MS2N04-D0BQN	217	218	219	220	22		
		43	44	45	MS2N05-B0BTN	221	222	223	224	23		
					MS2N05-C0BTN	225	226	227	228	25		
					MS2N05-D0BRN	229	230	231	232	17		
		33	34	35	MSM041B-0300	140	141	-	-	Magnetic sensor with plug ⁸⁾		
										58		
										59		

Drive end enclosure with additional drive shaft

In the versions MA05, MA06, MA10, MA11, MG10 and MG11, a second drive shaft end can be made available by removing the screws and cover.

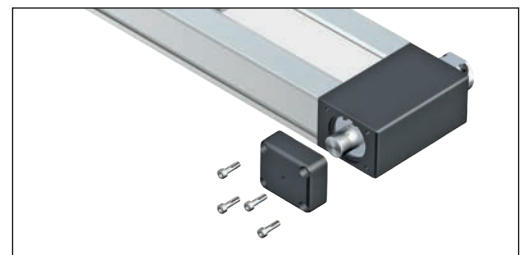

Version	Motor connector position			
	0°	90°	180°	270°
MA10 / MA11 MG10 / MG11	000	090 ★	180	270

★ standard delivery

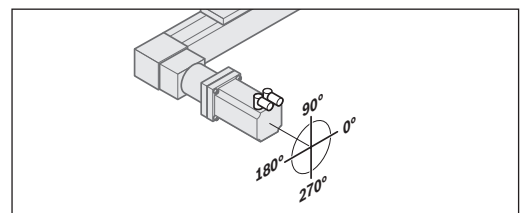

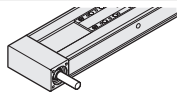
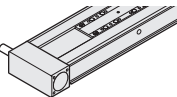
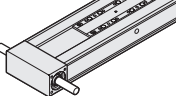
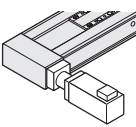
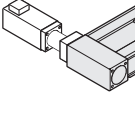
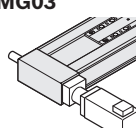
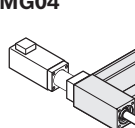

Explanation of the order parameters and order example → "Order example" chapter.

CKR-200

Short product name, length ¹⁾ CKR-200-NN-1, mm		Guideway		Drive			Lubrication ³⁾	Carriage						
Version		Standard	Center holes ²⁾	without keyway	with keyway	for gear unit ⁴⁾		Connection plate without		with				
				i = 1	i = 1			L _{ca} = (mm)		L _{ca} = (mm)				
								265	405	190	305			
Drive journal	MA01 	01	03	04	01	03	-	LSS	01	02	40	41		
	MA02 				02	04		LPG	-	302	-	341		
	MA03 													
Gear attachment	MG01 	01	03	04	-	-	-	LCF	-	-	141			
	MG02 												PG090	10
													PG120	12
	MG03 												PG090	11
MG04 		PG120	13	LCO	-	241								

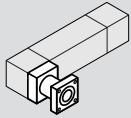
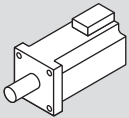
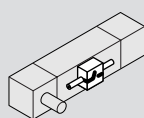
- 1) Length calculation of the linear motion system ⇒ "Project planning/calculation" chapter.
- 2) Center holes for simple combination with other linear motion systems and connection elements (⇒ Dimensional drawings).
Option 03: with center holes and fastening threads in the ground area of the frame. Selectable up to a length of L ≤ 2000 mm
Option 04: with center holes and fastening threads in the ground area of the frame. Selectable up to a length of L ≤ 5500 mm
- 3) Lubrication ⇒ "Lubrication" chapter.
- 4) Mounting kit for gear attachment
- 5) With servo motor attached, product only available as assembled in the chapter "Form of Delivery" (note position of motor connector).
- 6) Recommended motor, motor data and type designations ⇒ "Motors" chapter
- 7) Further information ⇒ "Switching system" chapter.
- 8) Assembly contains 1 x sensor, 1 x switch mounting plate including set screws and square nuts as well as 3 x cable holders including set screws
- 9) Switch configuration with magnetic sensor and mechanical/proximity switch together on one side is not possible.
Assembly contains 1 x sensor, 1 x switch mounting plate including mounting material
- 10) Switching angle can be attached only in conjunction with connection plate
- 11) Measurement report: 01 = Standard report; 02 = Measurement of frictional torque; 03 = Lead deviation (⇒ "Documentation" chapter)
- 12) Motor attachment consisting of: Adapter flange for gear unit, however "without gear unit". No motor connector position selectable.

Motor attachment ⁵⁾		Motor ⁶⁾				Switching system ⁷⁾		Documentation ¹¹⁾			
											
Gearing		Motor code		2 cables		1 cable		Motor connector position			
i = 3 i = 5 i = 10				without brake with brake		without brake with brake					
MA01	MA02	00				00				Without	
						- Switch		00		- Mounting channel	
						- Socket-plug				Magnetic sensor	
MA03					REED, changeover (NC: C+NC, NO: C+NO)		21		Hall, PNP normally closed (NC)		
					Hall, PNP normally open (NO)		23		Mounting channel		
					Socket-plug		17		01		
MG01 / MG02 / MG03 / MG04	-	00 ¹²⁾			00				Magnetic sensor with plug ⁸⁾		
	PG090	43	44	45	MS2N06-D1BNN	245	246	247	248	000	REED, changeover (NC: C+NC, NO: C+NO)
		MS2N07-B1BNN	253	254	255	256	090	Hall, PNP normally closed (NC)	59	02	
	PG120	33	34	35	MS2N07-C1BRN	261	262	263	264		180
					Mechanical	15		Proximity – PNP NC contact	11		
					Proximity – PNP NO contact	13		Cable duct	20		
	MS2N07-D1BNN	267	268	269	270	270	Switching angle ¹⁰⁾	1	16		
		2	26	Socket-plug	17						
	MS2N07-E1BNN	273	274	-	-						

Version	Motor connector position			
	0°	90°	180°	270°
MG01-MG04	000	090 ★	180	270

★ standard delivery

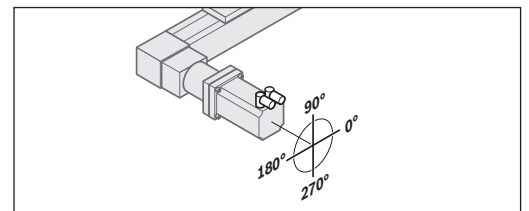

Explanation of the order parameters and order example → "Order example" chapter.

Frame CKR-070/-090/-110/-145

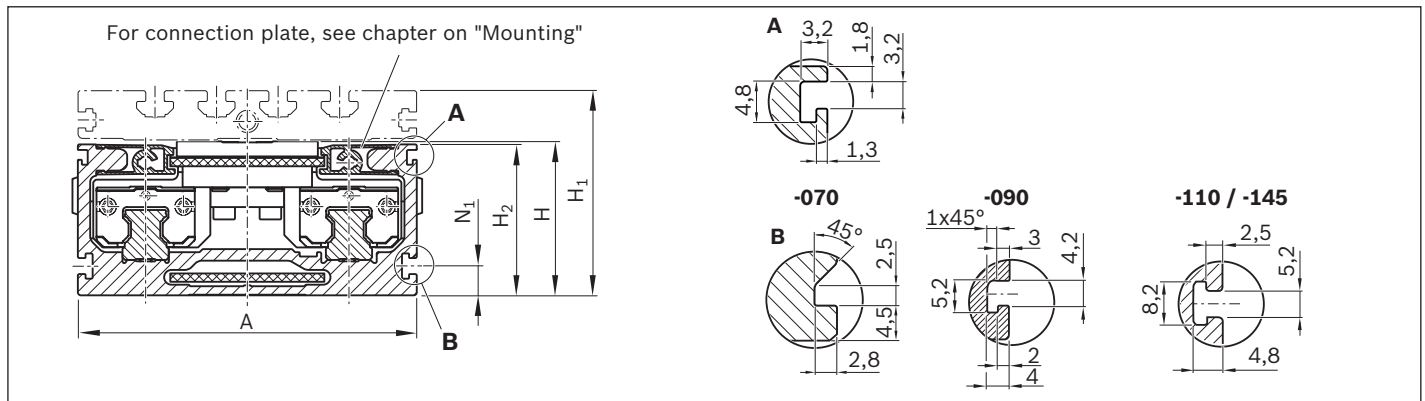
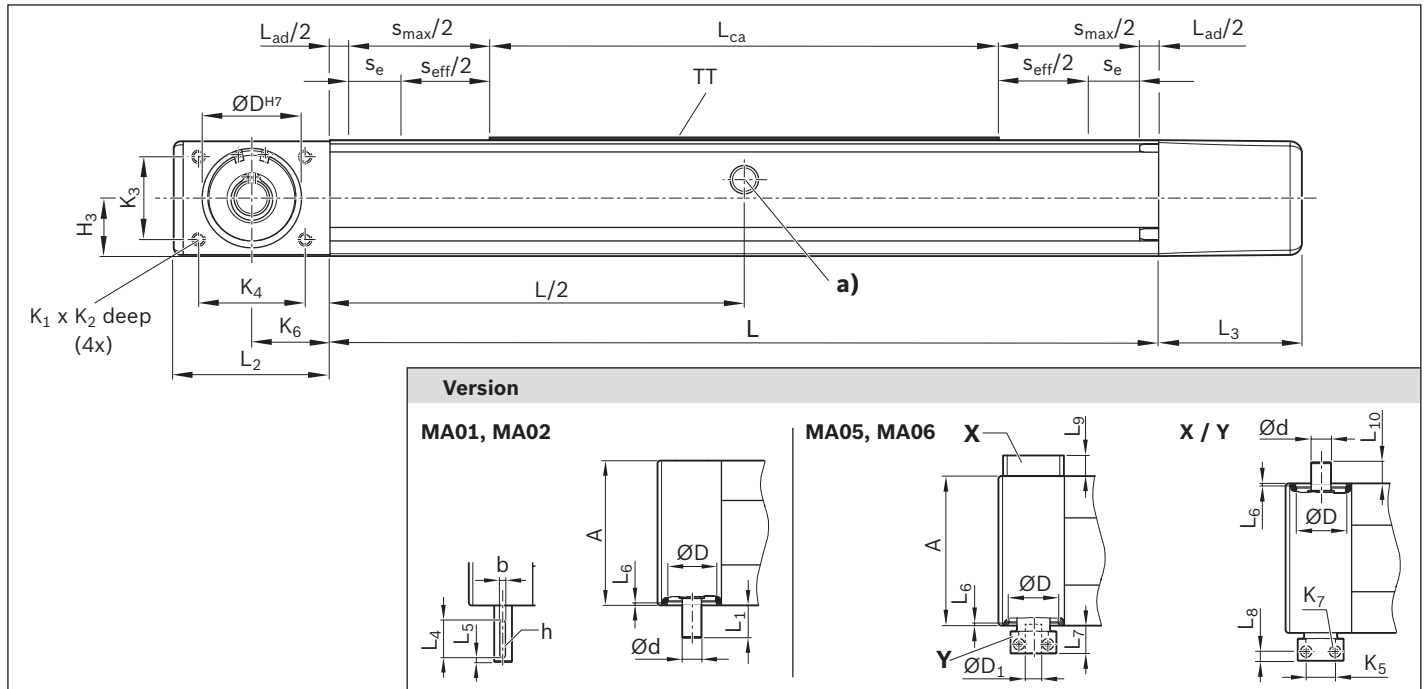

CKR	Dimensions (mm)														
	A	B	b ^{P9}	H	H ₁	H ₂	H ₃	h	ØD H7	ØD ₁ H7	h7	Ød h6	K ₁	K ₂	
-070	70	-	-	32	44.5	31.3	16.30	-	26.5	10	8	-	M3	6	
-090	90	-	3	40	56.0	39.0	19.50	1.8	34.0	14	10	-	M4	8	
-110	110	-	5	50	66.0	49.0	24.50	3.0	42.0	19	14	-	M5	10	
-145	145	-	6	65	85.0	64.0	32.00	3.5	49.0	24	19	-	M6	12	
-200	200	150	8	100	127.0	98.5	49.25	4.0	68.0	-	-	24	M8	15	

a) Lubrication bore on both sides (grease lubrication). ⇒ "Lubrication" chapter.

Straightness and flatness tolerance in accordance with DIN EN 12020-2.

Note: all dimensions in mm. Drawings not schematically to scale. Exact contours and dimensions can be found in the CAD model. CAD configurator available on the Internet at www.boschrexroth.com "Product configurators".

Frame CKR-200

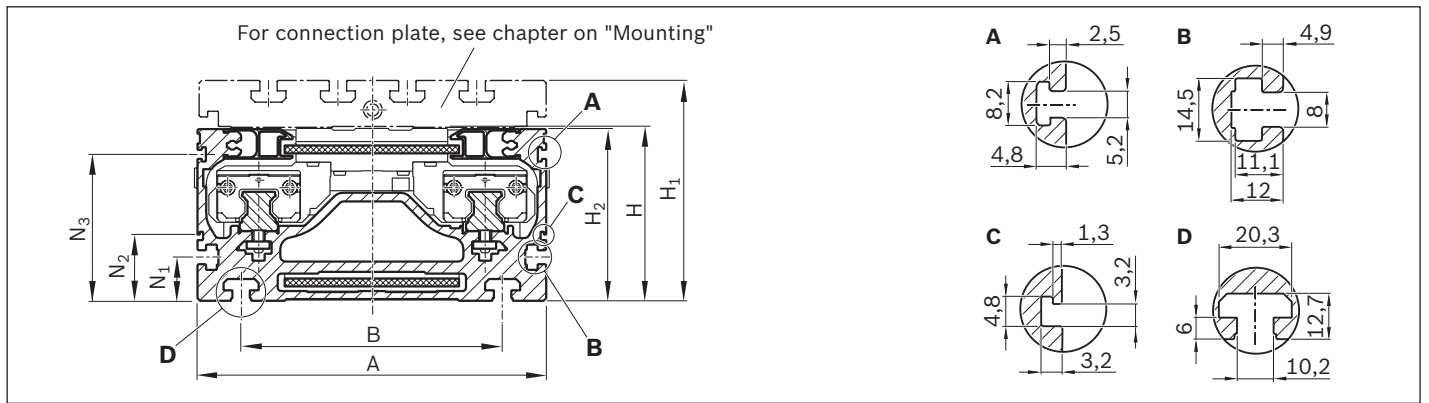
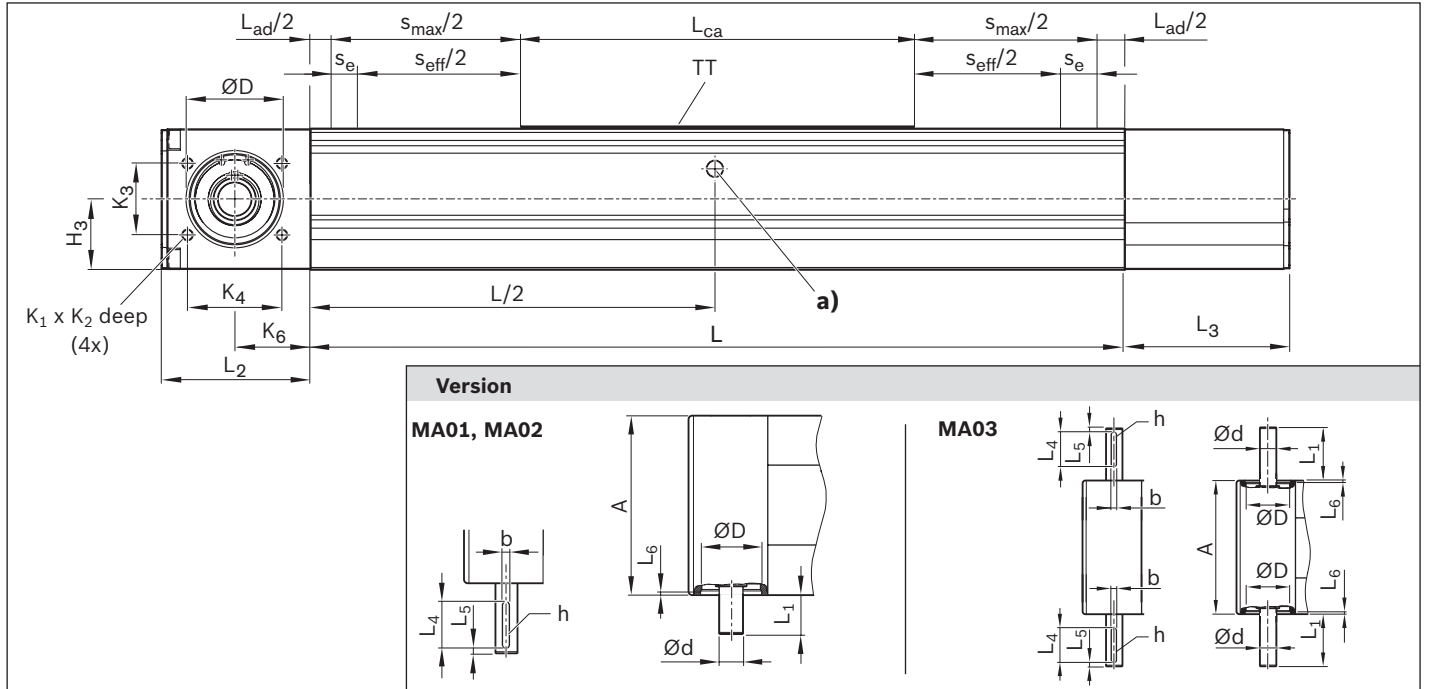

K_3	K_4	K_5 ± 0.1	K_6	K_7	L_1	L_2	L_3	L_4	L_5	L_6	L_7	L_8	L_9	L_{10}	N_1	N_2	N_3
12	29	14.4	18	M2.5 (ISO 4762)	14.5	36	42.0	-	-	3.0	14.5	5 ± 0.2	15	12.0	-	-	-
28	40	20.0	28	M4 (DIN 6912)	31.5	59	49.5	25	2	1.8	20.5	8 ± 0.2	15	12.5	7.6	-	-
35	45	25.0	33	M4 (ISO 4762)	31.5	66	60.5	25	2	2.0	22.0	8 ± 0.2	20	17.5	9.5	-	-
45	45	30.5	30	M5 (ISO 4762)	61.0	64	71.5	40	2	2.5	27.5	9 ± 0.1	20	17.5	9.5	-	-
50	66	-	53	-	61.0	104	115.0	40	3	2.5	-	-	-	-	25.0	38	84

See following pages for dimensional drawings for frames, carriages and motor attachment.
Length calculation of the linear motion system → "Technical data" and "Project planning/calculation" chapter.

- A** For switch mounting arrangements
- B** For mounting with clamping fixtures
- C** For mounting duct
- D** For fastening with sliding blocks
- TT = Carriage

Frame CKR-070/-090/-110/-145

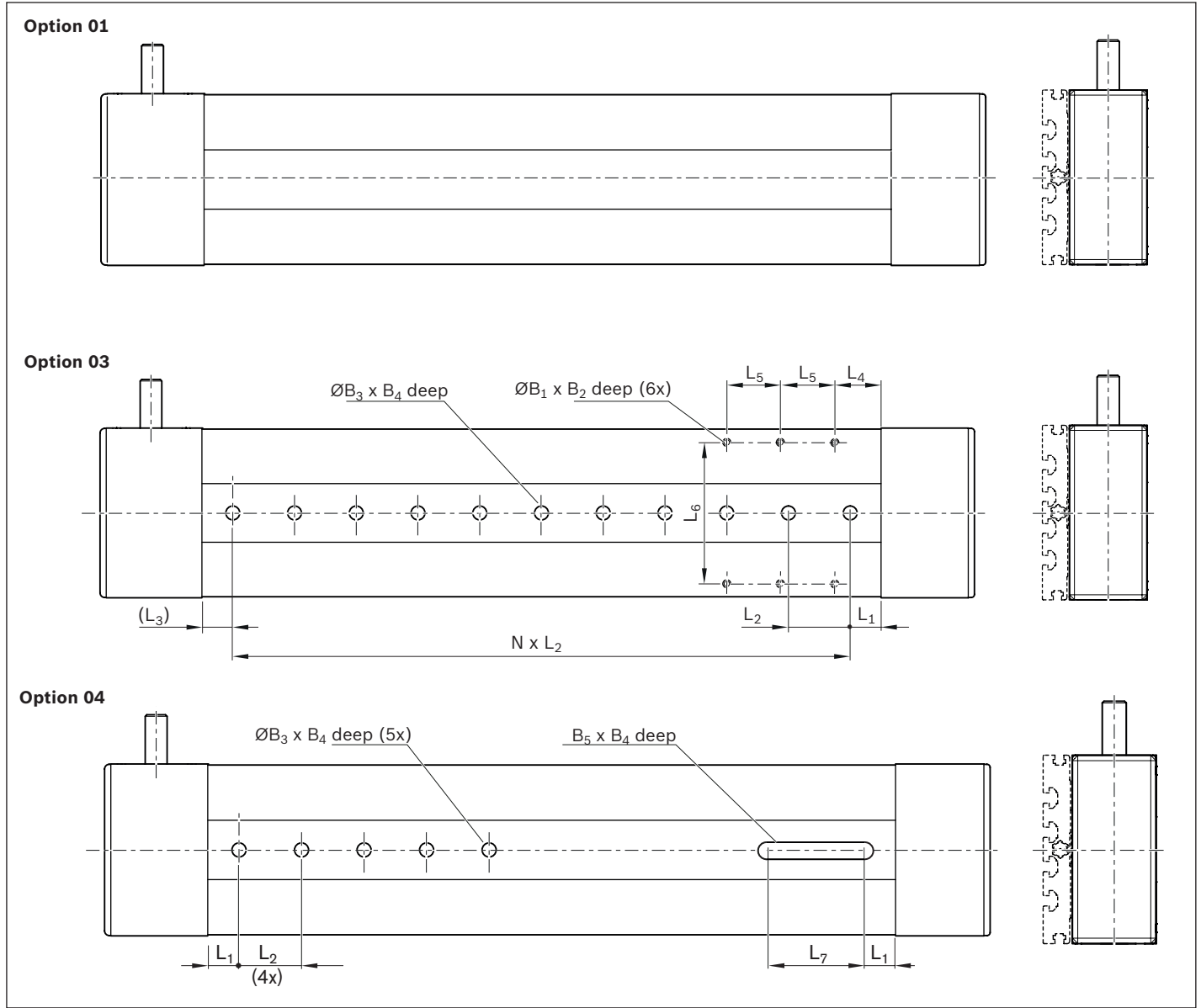

CKR	Option	Dimensions (mm)					L ₁	L ₂ ± 0.01	L ₃ (min)	L ₄	L ₅	L ₆	L ₇
		B ₁	B ₂	ØB ₃ ^{H7}	B ₄	B ₅ ^{H8}							
-070	03	M3	6.0	7	1.6	-	20	40	10	15	25	59	-
	04	-	-						7	-	-	-	-
-090	03	M4	7.5	9	2.1	-	20	40	10	30	35	76	-
	04	-	-						9	-	-	-	60
-110	03	M5	9.0	9	2.1	-	20	40	10	30	35	92	-
	04	-	-						9	-	-	-	60
-145	03	M6	13.0	12	2.1	-	20	40	10	30	35	124	-
	04	-	-						12	-	-	-	60
-200	03	M8	12.0	16	3.1	-	20	40	10	35	40	119	-
	04	-	-						16	-	-	-	60

Frame CKR-200

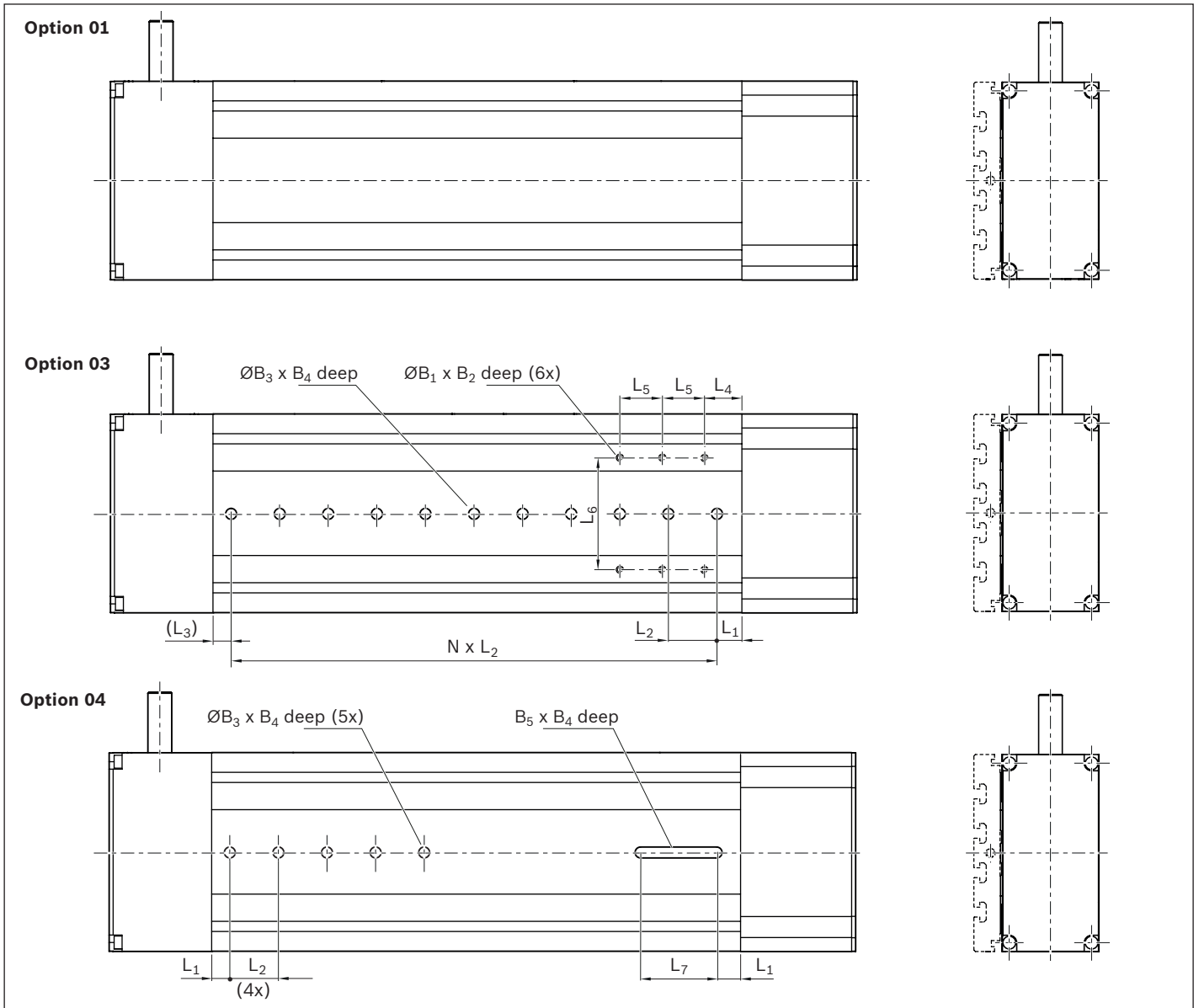

Views from below (ground area)

Option 01 / standard

Option 03 / with central holes

Option 04 / with central holes and long hole

Carriages CKR-070/-090/-110/-145/-200

Carriages without connection plate

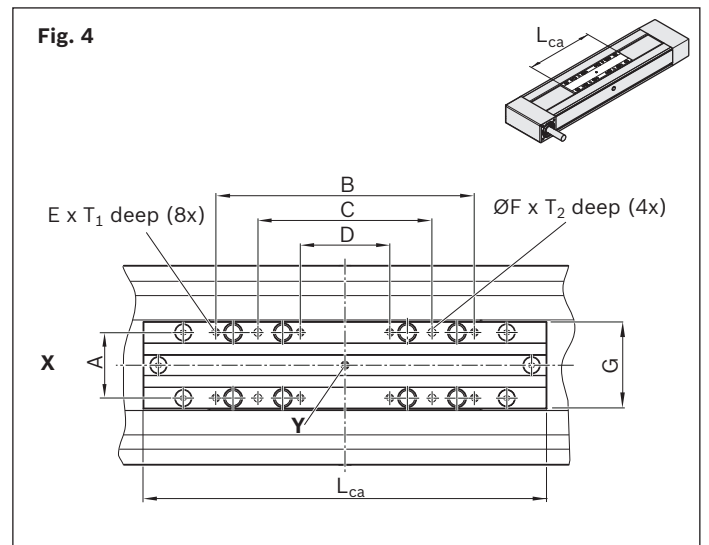
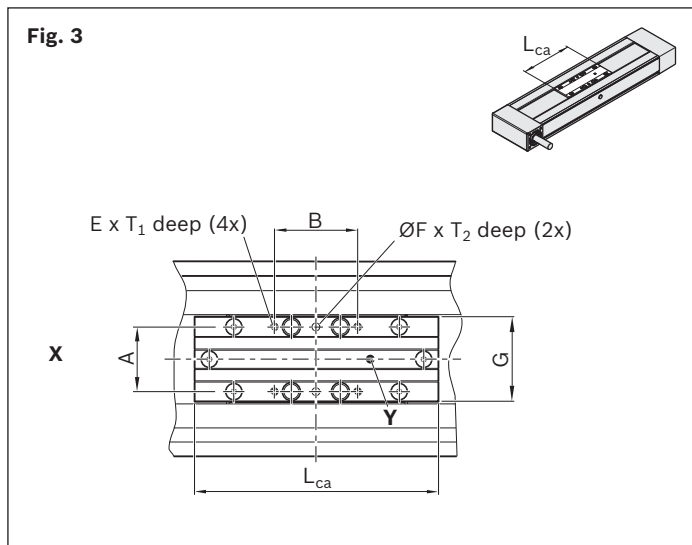
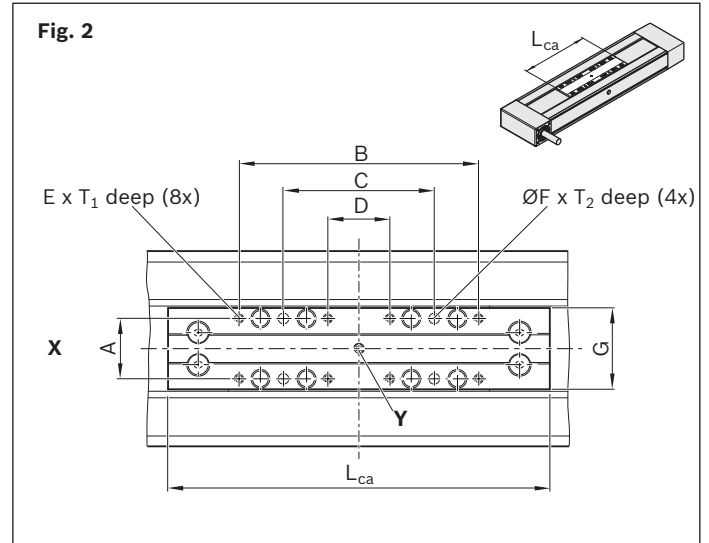
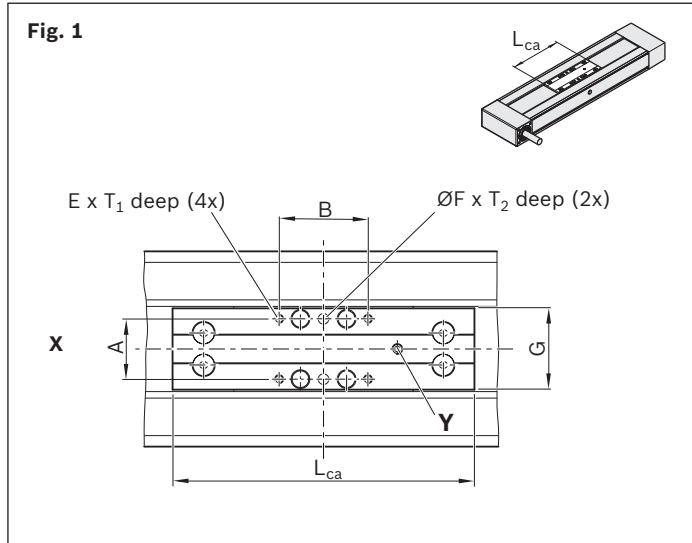

Carriages with connection plate¹⁾

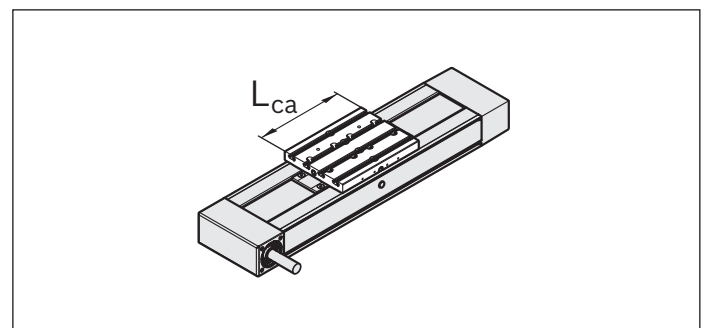
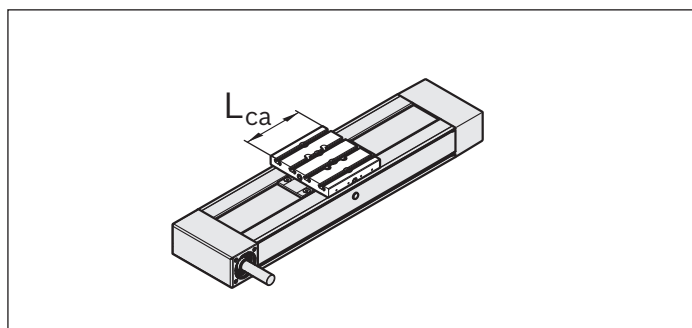

¹⁾ Dimensional drawings → "Connection plates" chapter

CKR	Figure	Dimensions (mm)									
		L _{ca}	A	B	C	D	E	ØF ^{H7}	G	T ₁	T ₂
-070	1	80	13.5	25	-	-	M3	3	21	6	6
	2	108		65	40	15					
-090	1	102	20	27	-	-	M4	4	27	8	6.5
	2	156		92	65	38					
-110	1	170	34	50	-	-	M5	6	46	10	6.5
	2	215		135	85	35					
-145	1	180	48	60	-	-	M6	6	62	12	7.5
	2	240		160	100	40					
-200	3	265	66	85	-	-	M8	8	87	16	10
	4	405		260	175	90					

X Drive side

Y Lubrication point for grease; sealed with set screw.

Supplementary information on the lubrication ➡ "Lubrication" chapter.

Motor attachment CKR-070/-090/-110/-145

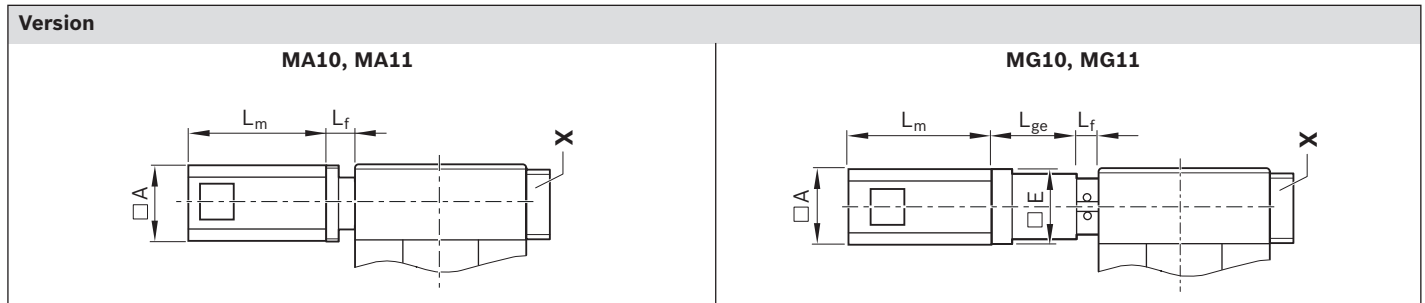

X: Drive end enclosure with additional drive shaft

In the versions MA10, MA11, MG10 and MG11, a second drive shaft end can be made available by removing the screws and cover.

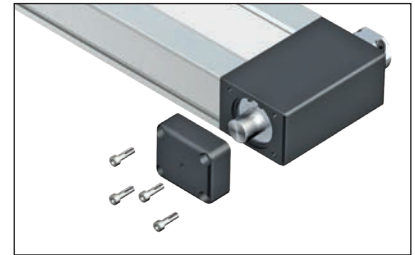

Motor attachment CKR-200

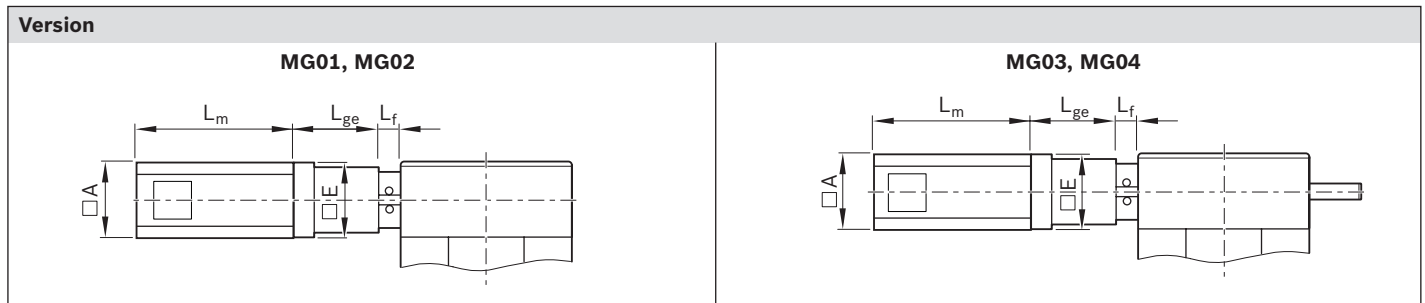

Motor attachment Option 00 (Adapter flange for mounting customer gear unit)

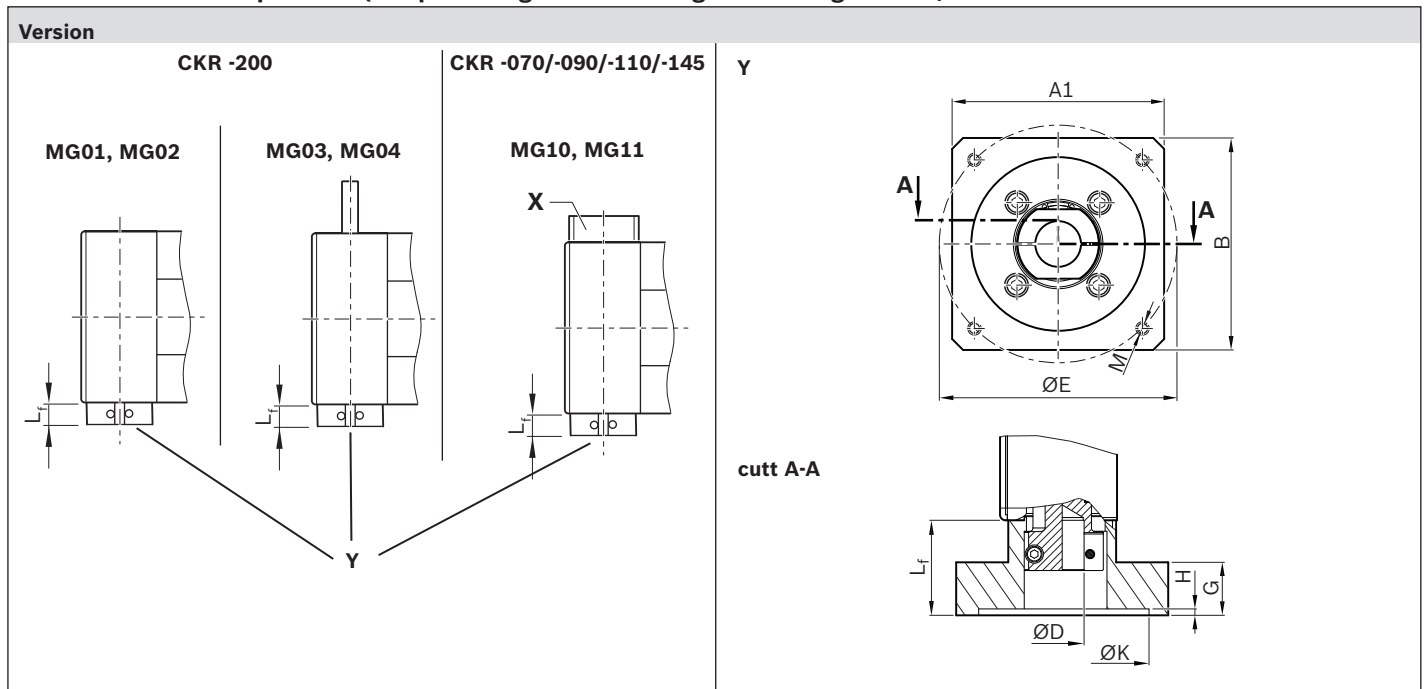

CKR	Version	Motor code	Dimensions (mm)				L _m	□ A	A1	B	∅ E	G	H	∅ D	∅ K	∅ M
			□ E	L _f	L _{ge}	□ A										
-070	MG10, MG11	MS2N03-B0BYN	55	29.5	61.5	see "Motors" chapter	-	-	∅ 40		34	8.5	2.5	10 ^{H7}	27 ^{+0.2}	4.3
		MSM019B-0300	40													
-090	MA10, MA11	MS2N04-D0BQN	-	34.5	-				51	51	44	8.5	4.5	14 ^{H7}	35.1 ^{+0.3}	4.5
	MG10, MG11	MS2N03-B0BYN	55	28.0	68.0											
		MSM031C-0300	70		75.0											
-110	MA10, MA11	MS2N05-D0BRN	55	46.0	-				57	55	44	-	7 ^{+0.4}	19 ^{H7}	35 ^{H7}	4.5
	MG10, MG11	MS2N03-B0BYN	55	30.5	68.0											
		MS2N03-D0BYN														
		MS2N04-B0BTN	80		75.0											
		MSM031C-0300	70		75.0											
-145	MA10, MA11	MS2N06-D1BNN	55	52.0	-				72	72	62	13	5.5 ^{+0.3}	24 ^{H7}	53 ^{+0.4}	5.5
	MG10, MG11	MS2N04-C0BTN	80	37.0	92.0											
		MS2N04-D0BQN														
		MS2N05-B0BTN	100		101.0											
		MSM041B-0300	90		97.0											
-200	MG01, MG02, MG03, MG04	MS2N06-D1BNN	120	45.0	124.5			95	95	80	-	6	22 ^{F7}	68.3 ^{+0.2}	6.6	
		MS2N07-B1BNN														
		MS2N07-C1BRN	150	75.0	154.0			120	120	108	-	8	32 ^{F7}	90.3 ^{+0.2}	9.0	
		MS2N07-E1BNN														

Adapter flange

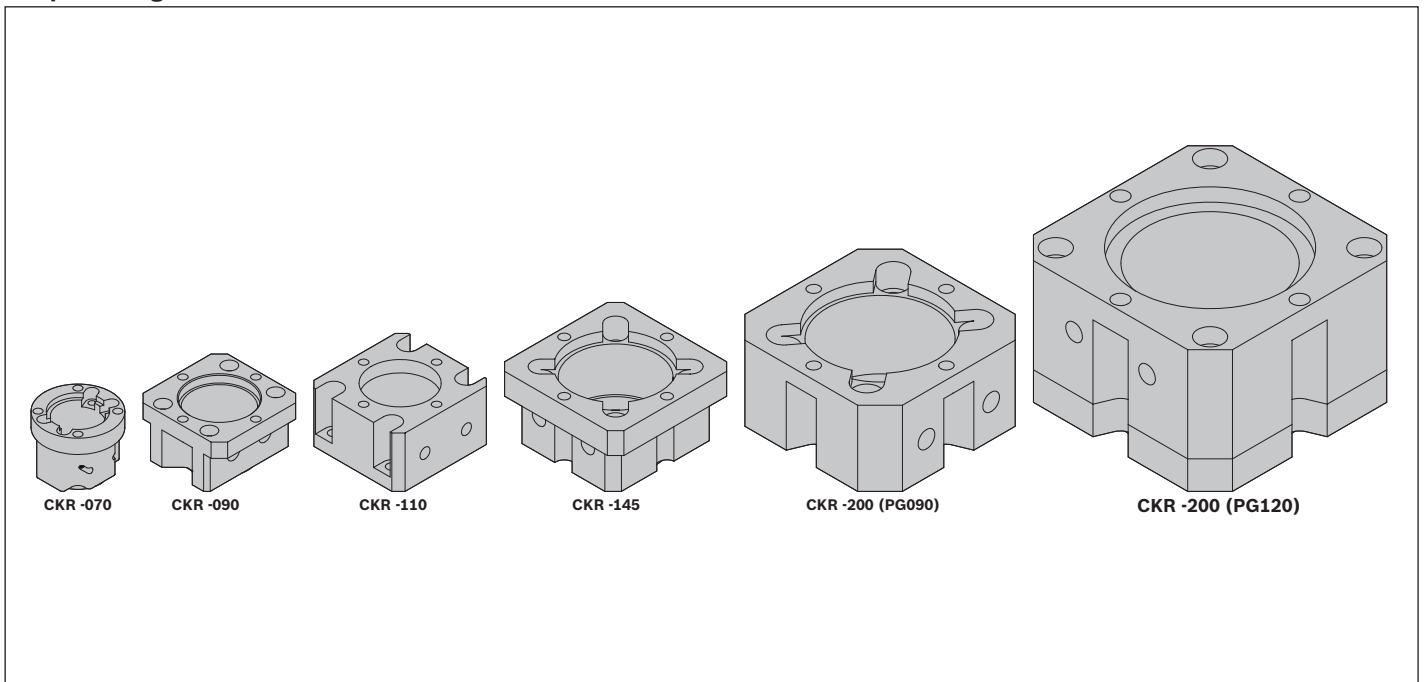

Attachments and accessories

Mounting/mounting accessories

Compact Modules fit together perfectly – fast and flexible

Minimal mounting times, maximum efficiency

Standardized interfaces significantly reduce the effort during mounting.

The mechanical systems have positive-locking interfaces throughout.

They can be quickly and accurately connected together without time-consuming alignment.

The result:

Users can respond flexibly to handling the different applications and tasks.

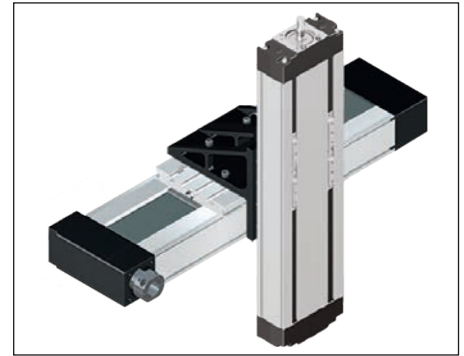

Supplementary information for connection technology

see the catalog "Connection technology for linear motion systems"



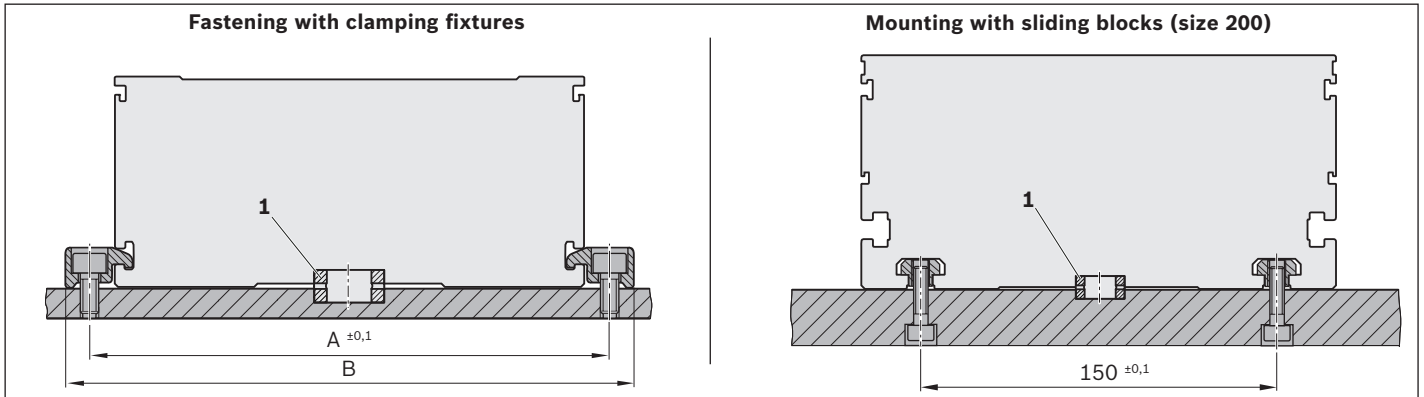

- 1** For Compact Modules with centering holes in the ground area (selection via the guideway option):
Use centering rings to better align to other Linear Motion Systems and connection elements.

⚠ Do not secure or support the Compact Modules at the end enclosures! The frame is the load-bearing part!

Size	Dimensions (mm)	
	A	B
-070	82	95
-090	102	112
-110	126	140
-145	161	175
-200	222	240

Mounting by means of special modification in the base surface of the frame is possible

⚠ Option guideway 03 already includes threaded holes in the ground area of the frame (see dimension drawings).

Size	Dimensions (mm)		
	A	B	C
-070	59	3	7.5
-090	76	4	7.5
-110	92	5	9.0
-145	124	6	13.0
-200	119	8	12.0

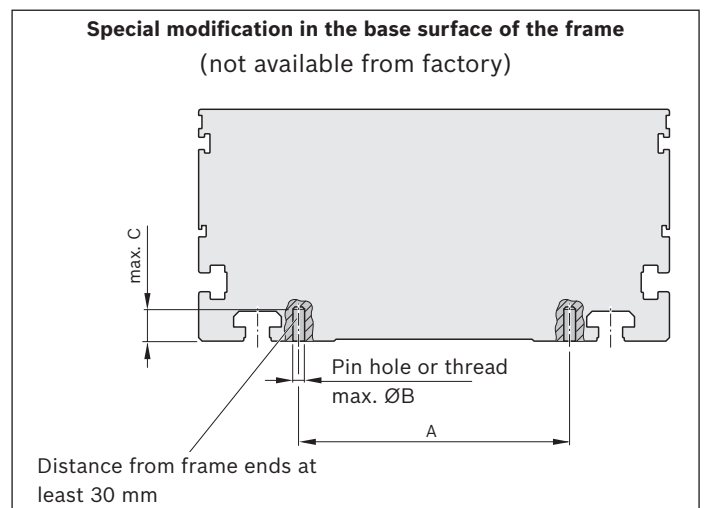

Mounting accessories

Recommended number of clamping fixtures:

- ▶ Type 1: 6/3¹⁾ pieces per meter and side
- ▶ Type 2: 4 per meter and side
- ▶ Type 3: 3 per meter and side
- ▶ Type 4: 3 per meter and side

¹⁾ For size 070

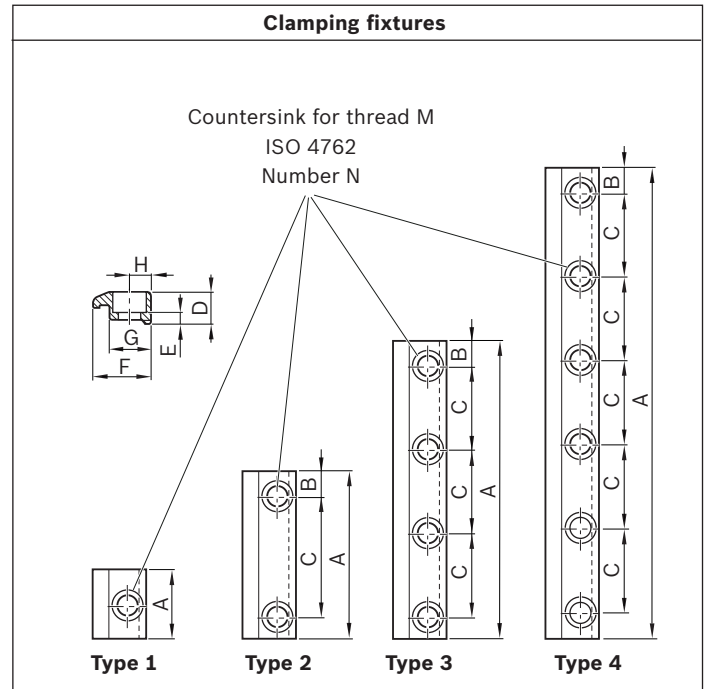

Size	for thread	Type	Number of holes N	Dimensions (mm)								Part number
				A	B	C	D	E	F	G	H	
-070	M5	1	1	22	-	-	10.0	4.8	15.0	12.2	6.5	R1419 010 01
		2	2	57	8.5	40	10.0	4.8	15.1	12.2	6.5	R1419 010 43
-090	M4	1	1	25	-	-	9.0	4.6	14.5	10.5	5.0	R0375 310 00
		3	4	87	6.0	25						R0375 310 02
		3	4	107	8.5	30						R0375 310 03
		2	2	72	11.0	50						R0375 310 32
		2	2	62	11.0	40						R0375 310 33
		3	4	87	13.5	20						R0375 310 38
		4	6	107	8.5	18						R0375 310 41
-110 / -145	M5	3	4	107	8.5	30	11.5	4.8	19.3	14.0	7.0	R0375 410 02
		3	4	77	8.5	20						R0375 410 26
		4	6	107	8.5	18						R0375 410 41
	M6	1	1	25	-	-	11.5	5.3	19.3	14.0	7.0	R0375 510 00
		3	4	142	11.0	40						R0375 510 02
		2	2	72	11.0	50						R0375 510 33
		2	2	62	11.0	40						R0375 510 34
		2	2	47	8.5	30						R0375 510 23
4	6	142	8.5	25	R0375 510 41							
-200	M8	2	2	108	19.0	70	27.5	16.3	29	19.0	9.0	R1175 290 26
		2	2	88	19.0	50		14.8				R1175 290 96
		2	2	78	19.0	40		14.8				R1175 290 97

CKR Compact Modules: When mounting the clamping fixtures, observe a minimum distance of 10 mm to the end face of the frame.

Sliding blocks, springs and strips

Recommended number of sliding blocks:
with 1 thread, 6 pieces per meter and side

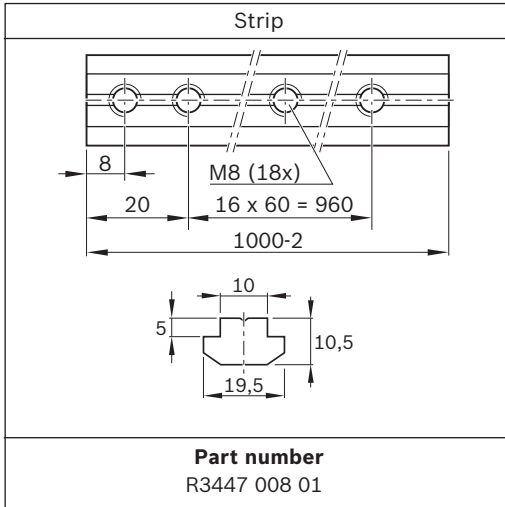

For fastening attachments on the connection plate.
The spring serves as assembly and positioning aid.

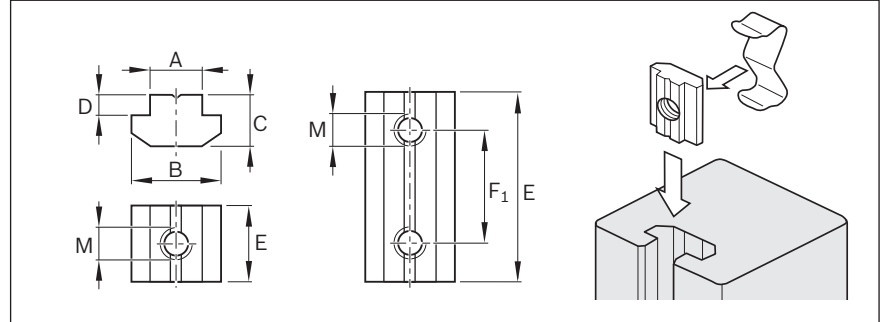

Size	for thread	Dimensions (mm)					Part number		
		A	B	C	D	E	F ₁	Sliding block	Spring
-070	M4	4	7.8	3.9	0.4	10	-	R0375 210 20	-
	M4					19	10	R0375 210 21	-
-090 / -110	M4	6	11.5	4.0	1.0	12	-	R3447 014 01	R3412 010 02
	M5					45	30	R0391 710 09	-
	M5					12	-	R3447 015 01	R3412 010 02
	M4					16	-	R3447 017 01	R3412 011 02
-145	M5	8	16.0	6.0	2.0	16	-	R3447 018 01	R3412 011 02
	M6					16	-	R3447 019 01	R3412 011 02
	M6					50	36	R0391 710 08	-
	M8					16	-	R3447 020 01	R3412 011 02
	M4					20	-	R3447 012 01	R3412 009 02
	M5					20	-	R3447 011 01	R3412 009 02
-200	M6	10	19.5	10.5	5.0	20	-	R3447 010 01	R3412 009 02
	M8					20	-	R3447 009 01	R3412 009 02
	M8					90	70	R0391 710 07	-

Centering rings

The centering ring serves as a positioning aid and for positive locking when mounting customer attachments to the carriage and the frame.

It creates a positive-locking connection with good reproducibility.

Material: Steel

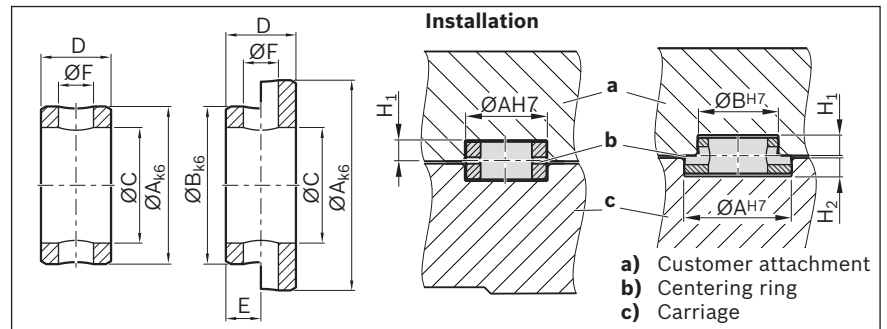
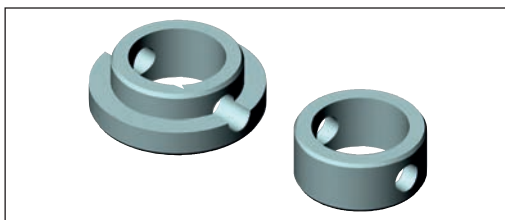

Ø Size (mm)	Dimensions (mm)								Part number
	A	B	C ±0.1	D -0.2	E +0.2	ØF	H ₁ +0.2	H ₂ +0.2	
5	5	-	3.4	3.0	-	1.6	1.6	-	R0396 605 42
7	7	-	5.5	3.0	-	1.6	1.6	-	R0396 605 43
9	9	-	6.6	4.0	-	2.0	2.1	-	R0396 605 44
12	12	-	9.0	4.0	-	2.0	2.1	-	R0396 605 45
16	16	-	11.0	6.0	-	3.0	3.1	-	R0396 605 46
7 - 5	7	5	3.4	3.0	1.5	1.6	1.6	1.6	R0396 605 47
9 - 5	9	5	3.4	3.5	1.5	1.6	2.1	1.6	R0396 605 48
9 - 7	9	7	5.5	3.5	1.5	1.6	2.1	1.6	R0396 605 49
12 - 9	12	9	6.6	4.0	2.0	2.0	2.1	2.1	R0396 605 50
16 - 12	16	12	9.0	5.0	2.0	2.0	2.1	3.1	R0396 605 51

Connection plates

CKK/CKR -070

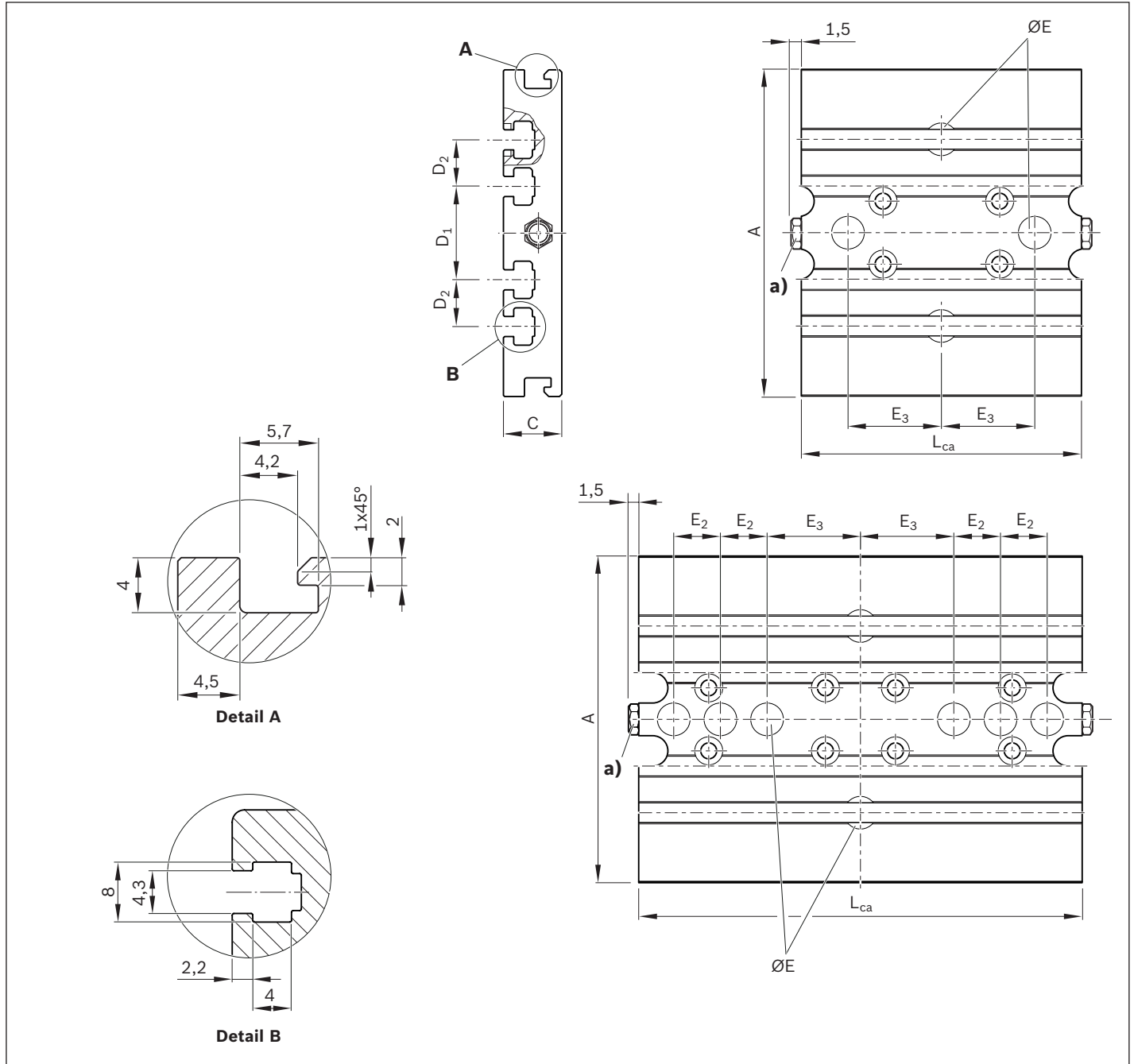

a) Funnel-type lube nipple DIN 3405-D4; lubrication possible from two sides (central lubrication only necessary with grease press on one of the two sides).

The connection plates differ in appearance in the representation. Shown here is the connection plate for CKR-070.

Function:

- ▶ Fastening of attachments (with sliding blocks)
- ▶ Lubrication option of the Ball Rail System and the Ball Screw Assembly possible via the connection plate
- ▶ For lube version LSS, LPG

The unit consists of:

- ▶ Connection plate
- ▶ Mounting accessories for fastening to the carriages
- ▶ Sliding blocks are not included with delivery

CKK/CKR	Dimensions (mm)								
	CKK	L _{ca} CKR	A	C	D ₁	D ₂	ØE ^{H7}	E ₂ ±0,01	E ₃ ±0,01
-070	60	60	70	12.5	20	10	7 - 1,6 ^{+0.2} deep	10	20
	95	95							

CKK/CKR	L _{ca} (mm)	Part number		Weight (kg)
		CKK	CKR	
-070	60	R0375 200 15	R0375 200 16	0.11
	95	R0375 200 10	R0375 200 11	0.17

CKK and CKR -090, -110, -145, -200

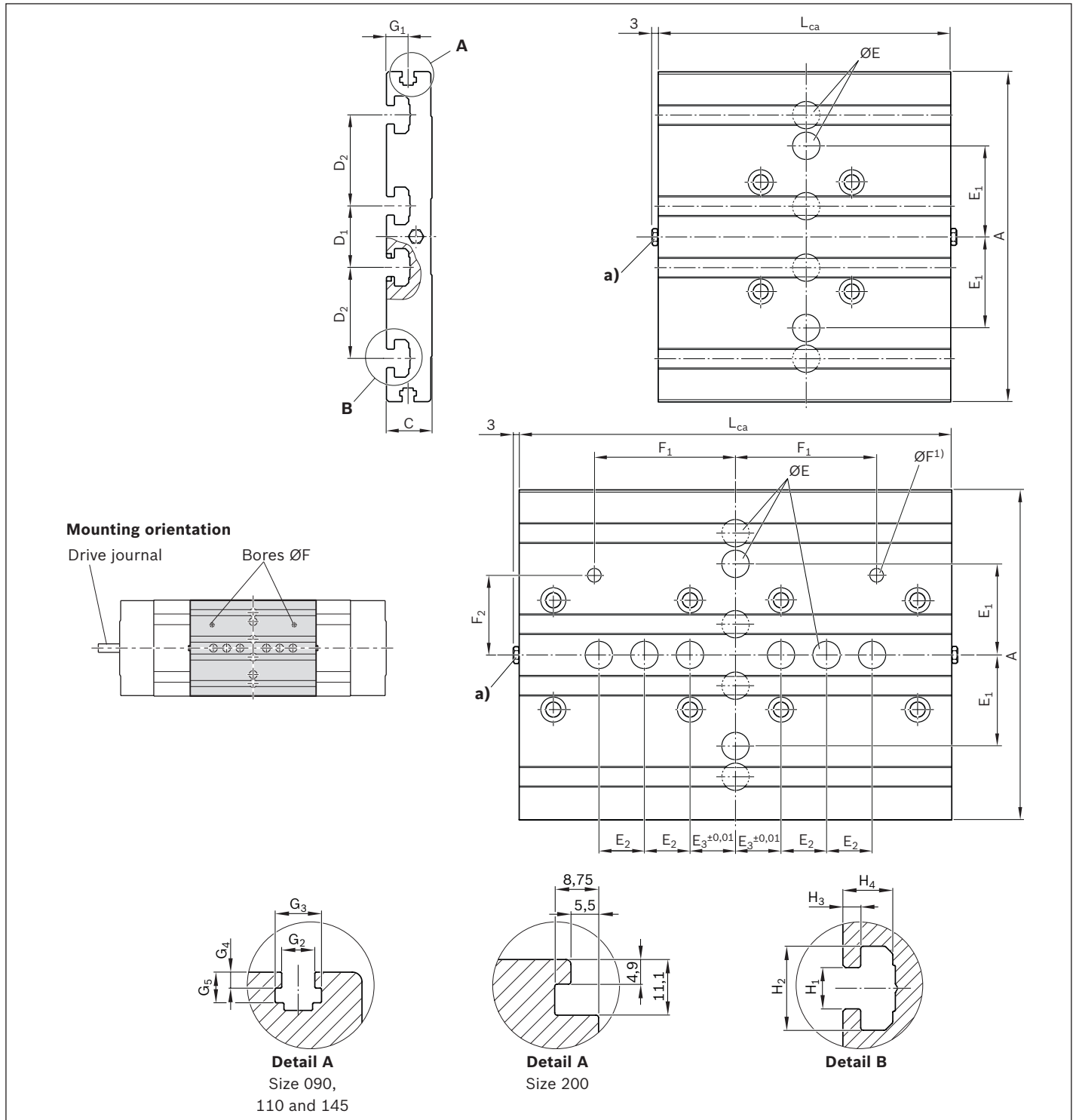

1) For customer attachment

- a) Funnel-type lube nipple AM8 x 1 for lube version LSS/LPG; lubrication possible from two sides (central lubrication only necessary with grease press on one of the two sides).
 Lube fittings for lube versions LCF/LCO see next page.

The connection plates differ in appearance in the representation. Shown here is the connection plate for CKK-145.

Function:

- ▶ Fastening of attachments (with sliding blocks)
- ▶ Lubrication option of the Ball Rail System and the Ball Screw Assembly possible via the connection plate
- ▶ For lube version LSS, LPG

The unit consists of:

- ▶ Connection plate
- ▶ Mounting accessories for fastening to the carriages
- ▶ Sliding blocks are not included with delivery

CKK/ CKR	Dimensions (mm)		A	C	D ₁	D ₂	ØE ^{H7}	E ₁ ±0.01	E ₂ ±0.01	E ₃ ±0.01	ØF ^{H7}	F ₁ ±0.01	F ₂ ±0.01	G ₁	G ₂	G ₃	G ₄	G ₅	H ₁	H ₂	H ₃	H ₄
	L _{ca}	CKK																				
-090	60	90	16	20	20	9 - 2.1 deep	-	-	-	-	-	-	-	7.9	4.2	7.6	2.0	4.3	6	12.0	3.5	7.7
	125																					
-110	60	110	16	20	20	9 - 2.1 deep	-	-	-	-	-	-	-	6.0	5.2	9.5	2.5	4.8	6	12.0	3.5	7.7
	155																					
-145	80	145	20	27	40	12 - 2.1 deep	40	-	-	-	-	-	-	10.0	5.2	9.5	2.5	4.8	8	16.5	3.5	9.8
	190																					
-200	190	200	27	40	40	16 - 3.1 deep	-	-	-	-	-	-	-	-	-	-	-	-	10	20.1	6.0	12.5
	305																					

CKK/CKR	L _{ca} (mm)		Part number		Weight (kg)	
	CKK	CKR	CKK	CKR	CKK	CKR
-090		60	R0375 300 15	R0375 300 16		0.18
		125	R0375 300 10	R0375 300 11		0.37
-110	60	100	R0375 400 15	R0375 400 16	0.23	0.38
		155	R0375 400 10	R0375 400 11	0.59	0.58
-145	80	125	R0375 500 15	R0375 500 16	0.50	0.81
		190	R0375 500 10	R0375 500 11	1.20	1.15
-200		190	R0375 600 15	R0375 600 16	2.20	2.20
		305	R0375 600 10	R0375 600 11	3.60	3.60

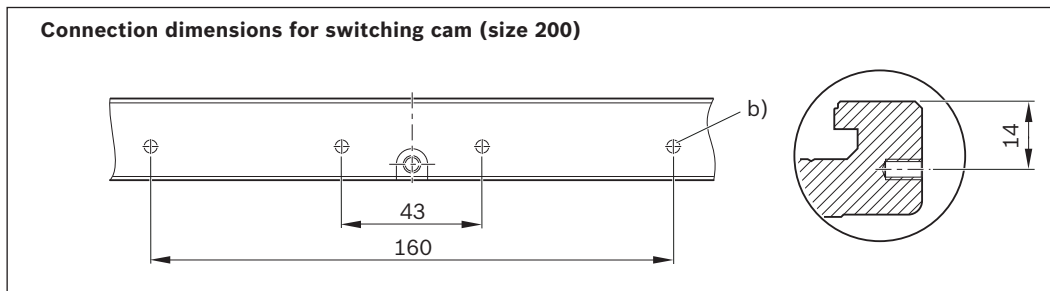

b) M4 - 6 deep

For lube version LCF/LCO

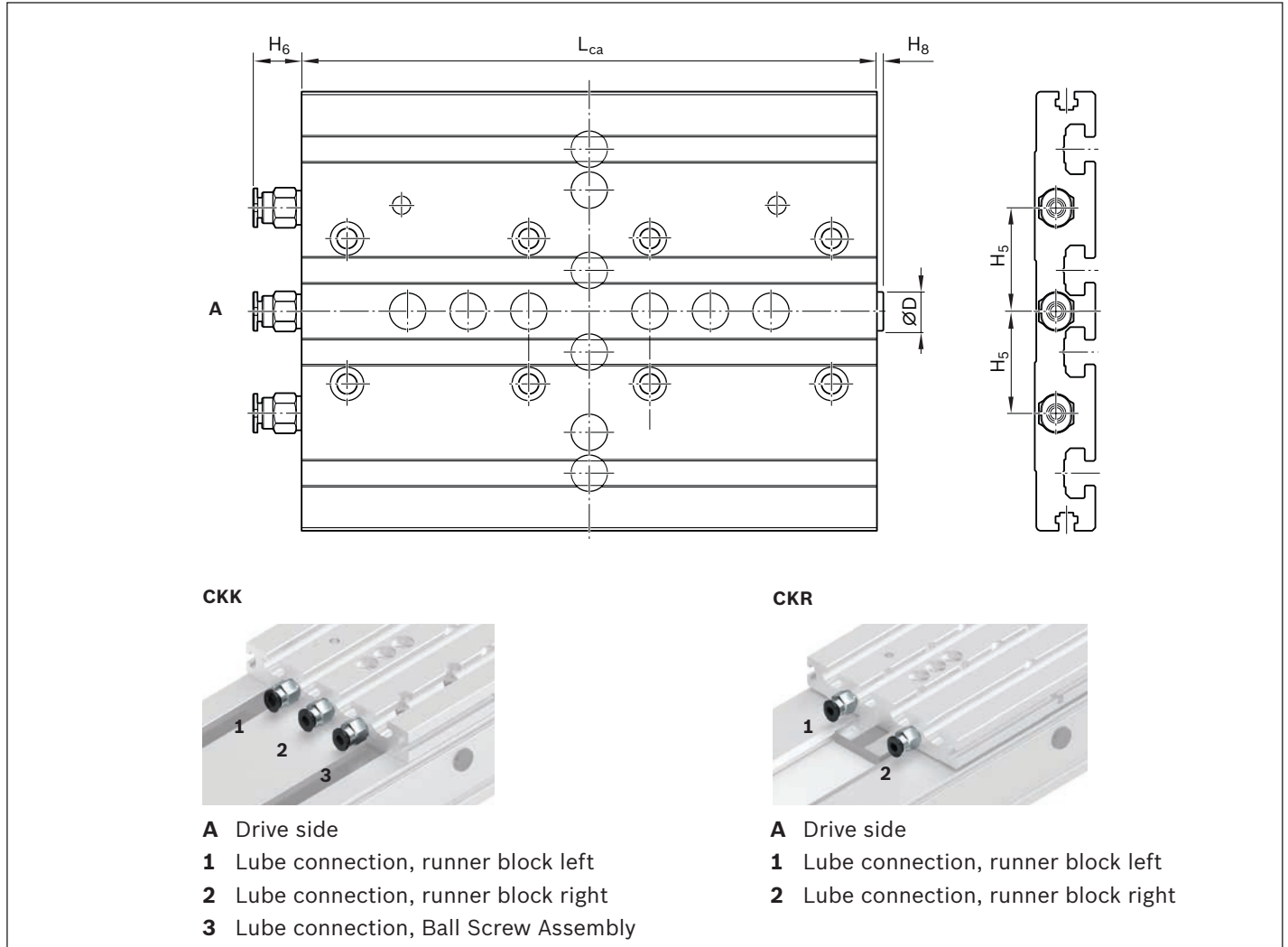

CKK/CKR	Dimensions (mm)					
	ØD	CKK	H ₅ CKR	H ₆	H ₈	L _{ca}
-070	-	-	-	-	-	-
-090	8.5	19	19	12.5	3	125
-110	8.5	20	40		3	155
-145	-	26	42		-	190
-200	-	31	55		-	305

More dimensions ⇒ "Connection plates" chapter.

Cover

Resist

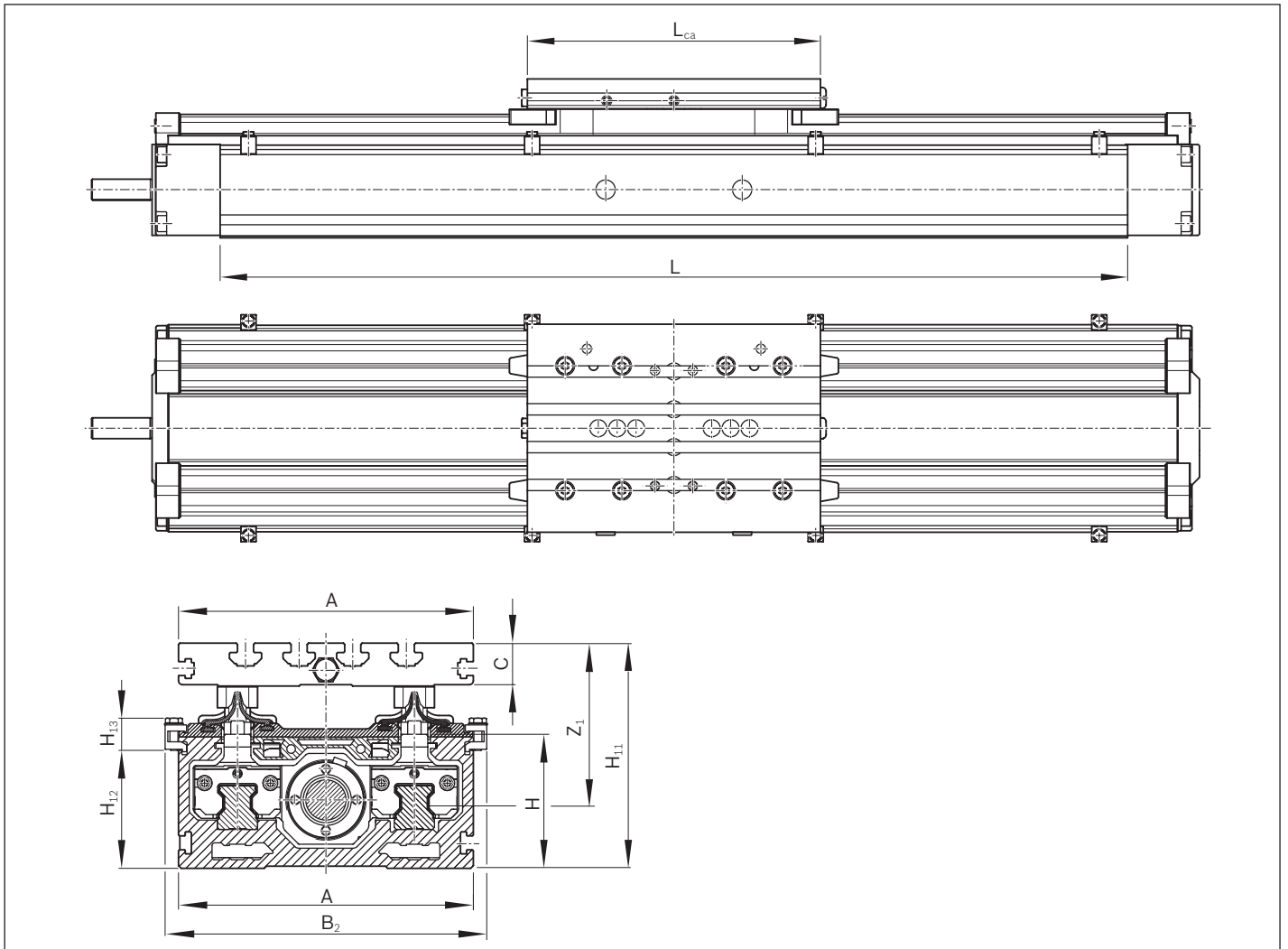

CKK	Dimensions (mm)									
	A	B ₂	C	H	H ₁₁	H ₁₂	H ₁₃	L _{ca}	Z ₁	
-110	100	120	16	50	84	44	12	155	60.7	
-145	145	155	20	65	105	59	12	190	71.6	
-200	200	212	27	100	150	82	24	305	86.4	

Z_1 = Application point of the effective force

Connecting shafts

Features

- ▶ Bridging of large distances between axes
- ▶ Can be mounted radially by split clamping hub
- ▶ Mounting and removal without shifting the aligned axes
- ▶ Backlash-free and torsionally stiff

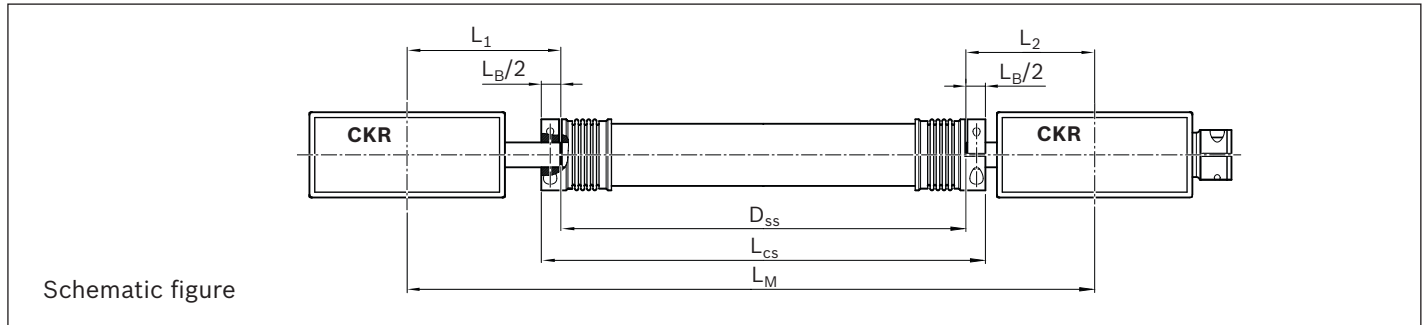

CKR-070

Material

Coupling hub: high-strength aluminum

Elastomer circle: precisely manufactured, extremely wear resistant, and thermally stable plastic

Connecting tube: high-precision aluminum tube

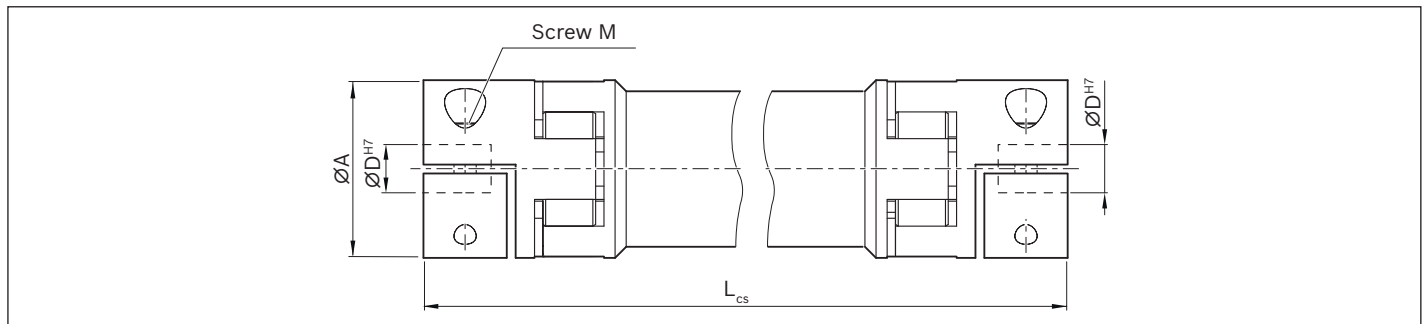

CKR-090, -110, -145, -200

Material

Bellows: highly flexible stainless steel

Connecting tube and clamping hub: Aluminum

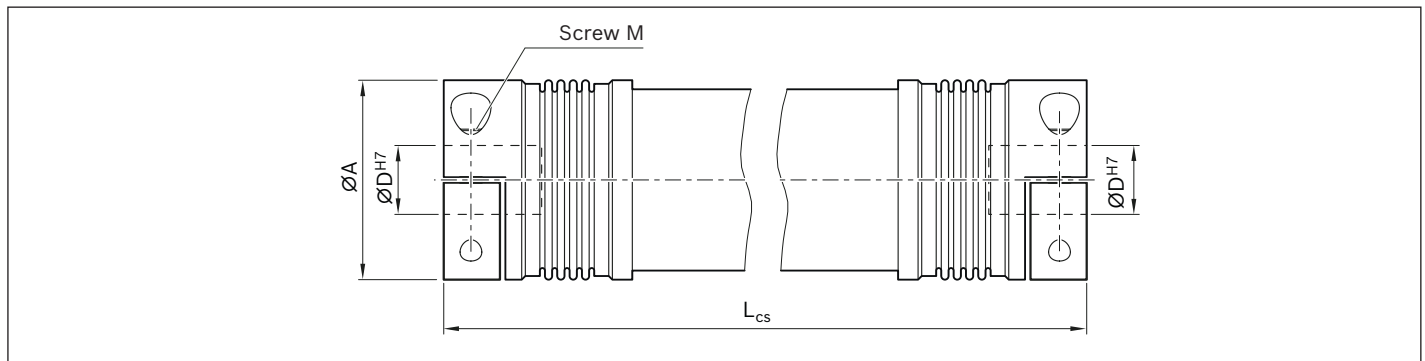

Size	Part number	Dimensions (mm)						M_A (Nm)
		A	D	M	L_B	$L_{cs\ min}$	$L_{cs\ max}$	
-070	R0391 510 22	30	8	M4	21	95	2,400	4
-090	R0391 510 16	40	10	M4	22	105	3,000	5
-110	R0391 510 20	40	14	M4	22	105	3,000	5
-145	R0391 510 18	55	19	M6	32	150	3,000	15
-200	R0391 510 19	83	24	M10	50	200	3,000	70

Size	M_S (Nm)	M_{cs} (Nm)	Mass moment of inertia ($10^{-6}\ kgm^2$)	Weight (kg)
-070	25	12.5	$0.090 \cdot (L_{cs} (mm) - 80) + 30$	$0.00054 \cdot (L_{cs} (mm) - 80) + 0.12$
-090	17	10.0	$0.032 \cdot (L_{cs} (mm) - 80) + 68.2$	$0.00090 \cdot (L_{cs} (mm) - 80) + 0.21$
-110	17	10.0	$0.032 \cdot (L_{cs} (mm) - 80) + 68.2$	$0.00090 \cdot (L_{cs} (mm) - 80) + 0.21$
-145	45	30.0	$0.670 \cdot (L_{cs} (mm) - 118) + 246$	$0.00120 \cdot (L_{cs} (mm) - 118) + 0.62$
-200	170	170.0	$4.500 \cdot (L_{cs} (mm) - 160) + 2,000$	$0.00320 \cdot (L_{cs} (mm) - 160) + 2.00$

Bending-critical speed

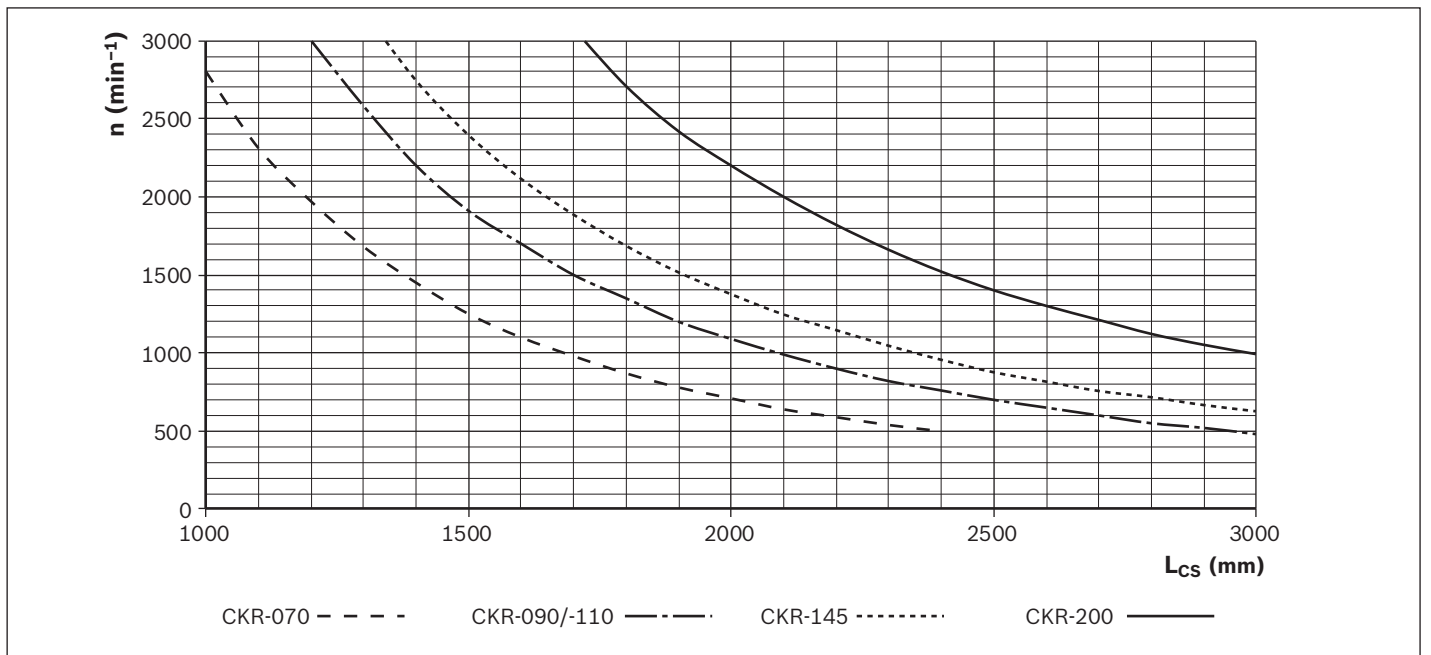

Order

Please state the part number and length L_{cs} .
e.g.: R0391 510 20, $L_{cs} = 550\ mm$

$$L_{cs} = D_{SS} + L_B$$

$$D_{SS} = L_M - L_1 - L_2$$

L_1/L_2 : For the calculation, refer to the dimensional drawings

- D_{SS} = Distance drive journals
- L_{cs} = Overall length of the connecting shaft
- L_M = Center-to-center distance between Compact Modules
- M_A = Tightening torque of screws
- M_{cs} = Rated torque of connecting shaft
- M_S = Peak torque of connecting shaft
- n = Rpm (min^{-1})
- L_{cs} = Overall length of the connecting shaft (mm)

Combination possibilities for multi-axis systems with connecting shaft

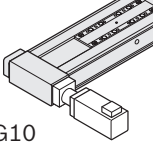
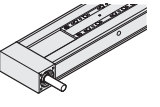
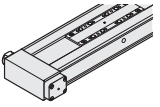
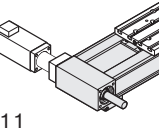
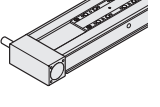
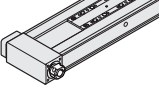
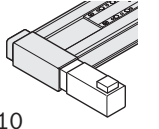
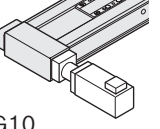
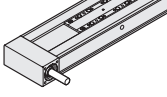
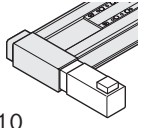
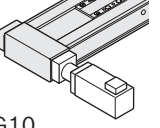
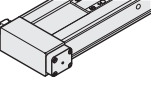
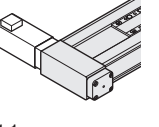
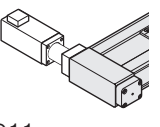
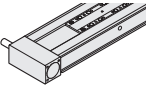
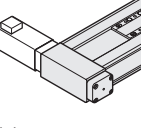
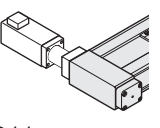
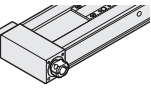
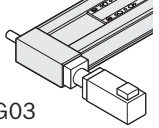
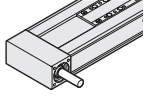
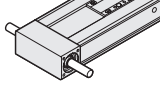
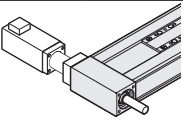
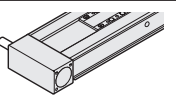
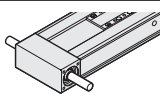
Size	Version				
-070	 MG10		↔	 MA01	 MA06
	 MG11			 MA02	 MA05
-090 -110 -145	 MA10	 MG10	↔	 MA01	
	 MA10	 MG10		 MA06	
	 MA11	 MG11	↔	 MA02	
	 MA11	 MG11		 MA05	
-200	 MG03		↔	 MA01	 MA03
	 MG04			 MA02	 MA03

Drive end enclosure with additional drive shaft

In types MA05, MA06, MA10, MA11, MG10, and MG11 a second drive shaft end can be made available by removing the screws and cover.

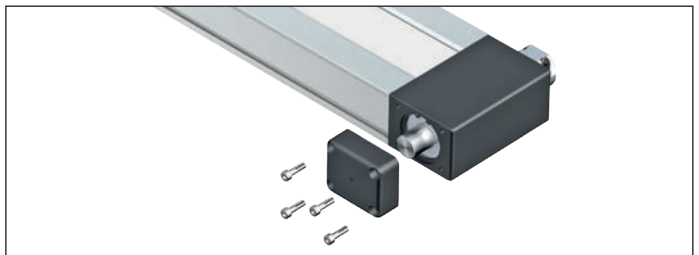

Cover

By attaching the cover, the open end of the drive (clamping hub) is closed.
 This means there is no longer any risk of injury from the rotating motor holder.

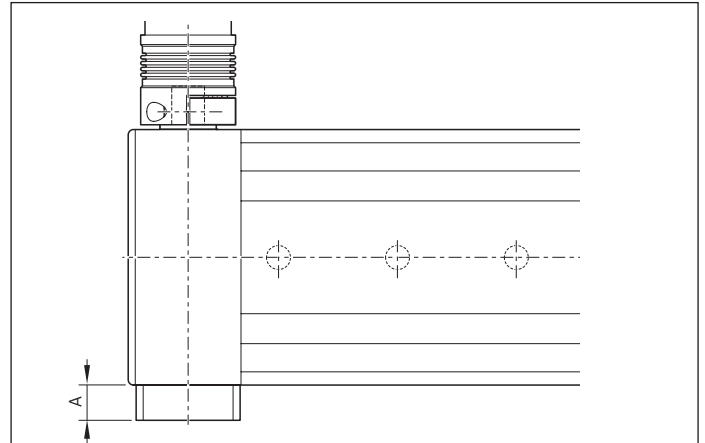
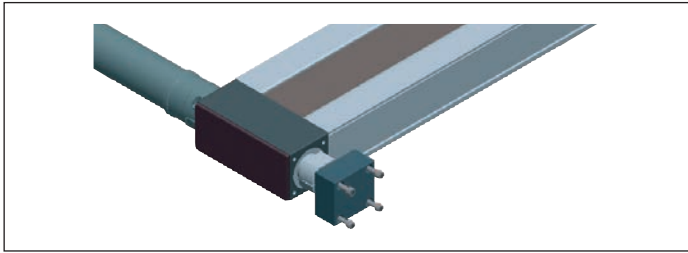

Size	Dimension (mm)	Part number	
		A	
-070	20	R0375 200 09	
-090	24	R0375 300 09	
-110	26	R0375 400 09	
-145	31	R0375 500 09	

Nozzle pipe

For manual grease guns.
 For the lubrication of funnel-type and ball-type lube nipples.

Scope of delivery:

nozzle pipe, interchangeable insert A for funnel-type lube nipple, interchangeable insert B for ball-type lube nipple.

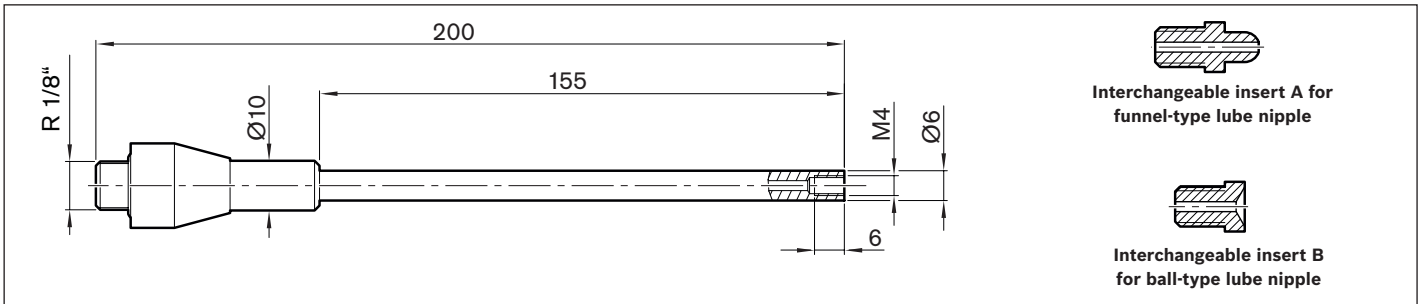

Material number	Weight (g)
R345503106	158

Frequency meter

For checking the toothed belt pre-tension on linear axes with toothed belt drive as well as the setting of the toothed belt pre-tensioning when driven by a belt pulley.

Scope of delivery:

Frequency meter TECO-S MINI, Plug-in measuring head, extension cable, leather belt bag.



Material number
R913057897

Motors

Motor attachment kits according to customer specification

The motor of linear motion systems with Ball Screw Assembly is attached by either an attachment kit with flange and coupling (MF) or a belt side drive (RV).

The available combinations are shown in the "Configuration and ordering" selection tables for each size. In addition to motor attachment kits for Rexroth motors, attachment kits for motors according to customer specification can also be ordered. In order to determine the appropriate attachment kit, the connection geometry of the motor is crucial. Characteristics required to clearly determine motor geometry are shown below.

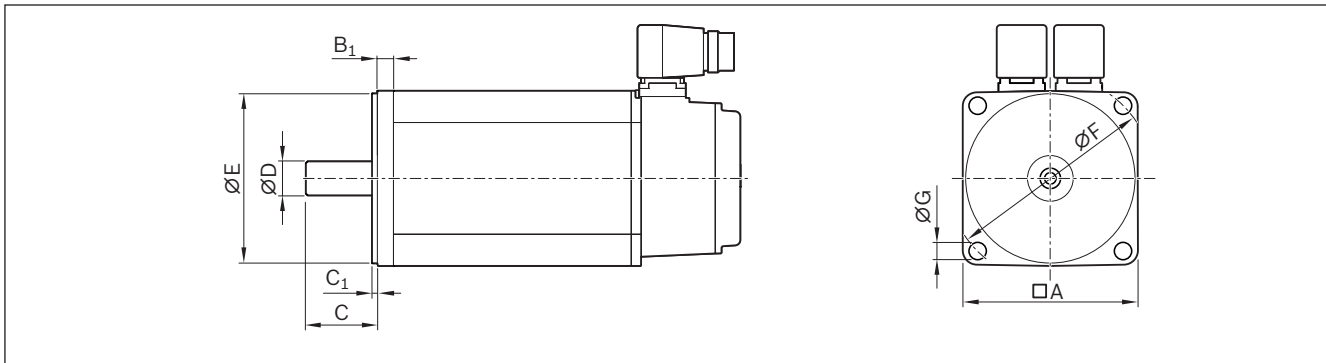

The dimensions queried result in a unique "motor geometry code":

	□□	-	□□	-	□□□□	-	□□□□	-	□□□□	-	M	□□	-	□□□□	-	□□□□
ØD	=	Shaft diameter														
C	=	Shaft length														
ØE	=	Centering diameter														
C₁	=	Centering depth														
ØF	=	Pitch diameter														
ØG	=	Through-hole for mounting screw (specify thread diameter)														
B₁	=	Flange thickness														
A	=	Flange edge dimension														

Example illustration of servo motor IndraDyn S Type MSK040C

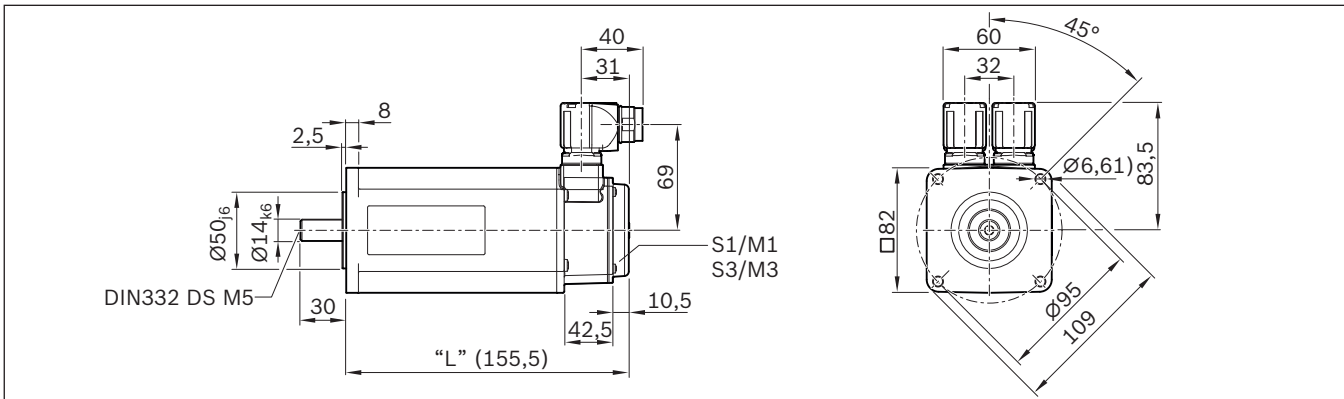

1 4 - 3 0 - 0 5 0 - 2 . 5 - 0 9 5 - M 0 6 - 0 0 8 - 0 8 2

¹⁾ The drill hole $\varnothing 6.6$ mm results in the type designation M06 for the geometry motor code (nominal thread diameter mounting screw M6).

Motor attachment kits for motors according to customer specification can be configured using the online configurator in the eShop. To do this, select the "Attachment kits for motors according to customer specification" option.

Enter motor geometry in the input dialog box. The dimensions can be entered directly or by using a drop-down menu.

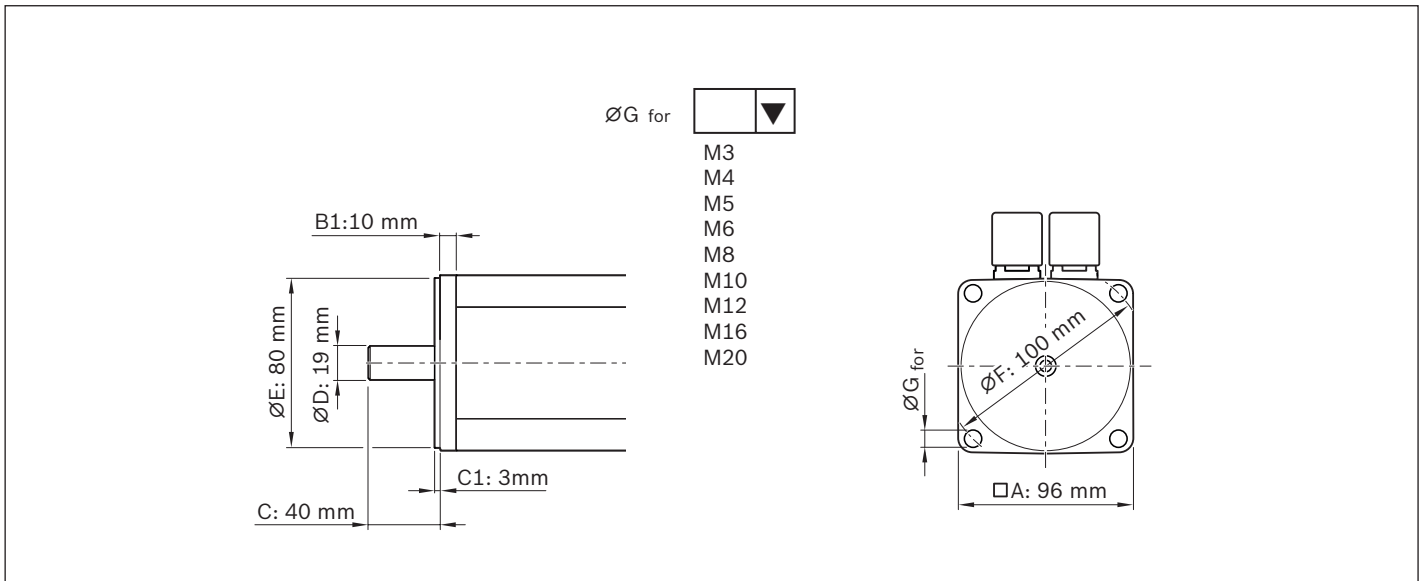

IndraDyn S - MSM servo motors

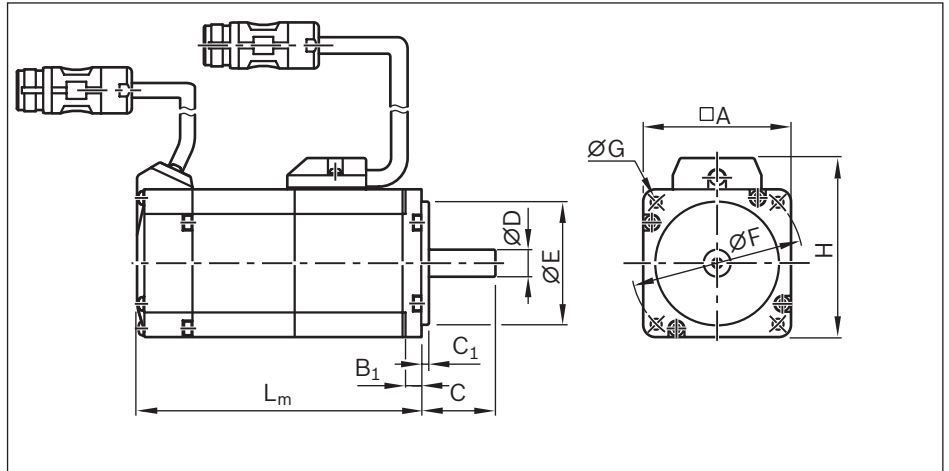

Motor schematic

Motor code	Dimensions (mm)									
	A	B ₁	C	C ₁	Ø D _{k6}	Ø E _{j7}	Ø F	Ø G	without	L _m Brake with
MSM 019A-0300	38	6.0	25	3	8	30	45	3.4	72.0	102.0
MSM 019B-0300	38	6.0	25	3	8	30	45	3.4	92.0	122.0
MSM 031B-0300	60	6.5	30	3	11	50	70	4.5	79.0	115.5
MSM 031C-0300	60	6.5	30	3	14	50	70	4.5	98.5	135.0
MSM 041B-0300	80	6.0	35	3	19	70	90	6.0	112.0	149.0

Version:

- ▶ Plain shaft without shaft seal
- ▶ M5 multi-turn absolute encoder (20-bit, absolute encoder function only available with backup battery)
- ▶ Cooling system: natural convection
- ▶ IP54 rating (shaft: IP40)
- ▶ With or without holding brake
- ▶ M17 metal round connector

Note

Motors are available with control units and controllers. For more information on motors, controllers and control systems, please refer to the following Rexroth catalogs:

- ▶ Drive System Rexroth IndraDrive R999000018
- ▶ Automation systems and control components, R999000026

Motor data									Motor connection	Brake	Type code	Part number
n_{max} (min^{-1})	M_0 (Nm)	M_{max} (Nm)	M_{br} (Nm)	J_m (kgm^2)	J_{br} (kgm^2)	m_m (kg)	m_{br} (kg)					
5,000	0.16	0.48	0.29	0.0000025	0.0000002	0.32	0.21	2	N	MSM 019A-0300-NN-M5-MH0	R911344209	
									Y	MSM 019A-0300-NN-M5-MH1	R911344210	
5,000	0.32	0.95	0.29	0.0000051	0.0000002	0.47	0.21	2	N	MSM 019B-0300-NN-M5-MH0	R911344211	
									Y	MSM 019B-0300-NN-M5-MH1	R911344212	
5,000	0.64	1.91	1.27	0.0000140	0.0000018	0.82	0.48	2	N	MSM 031B-0300-NN-M5-MH0	R911344213	
									Y	MSM 031B-0300-NN-M5-MH1	R911344214	
5,000	1.30	3.80	1.27	0.0000260	0.0000018	1.20	0.50	2	N	MSM 031C-0300-NN-M5-MH0	R911344215	
									Y	MSM 031C-0300-NN-M5-MH1	R911344216	
4,500	2.40	7.10	2.45	0.0000870	0.0000075	2.30	0.80	2	N	MSM 041B-0300-NN-M5-MH0	R911344217	
									Y	MSM 041B-0300-NN-M5-MH1	R911344218	

Motor characteristic
(Schematic)

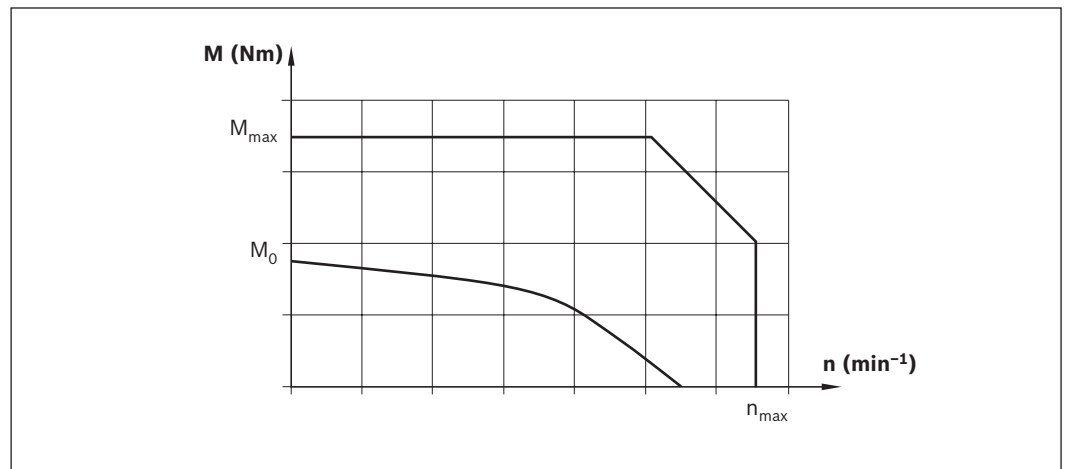

IndraDyn S - MS2N servo motors

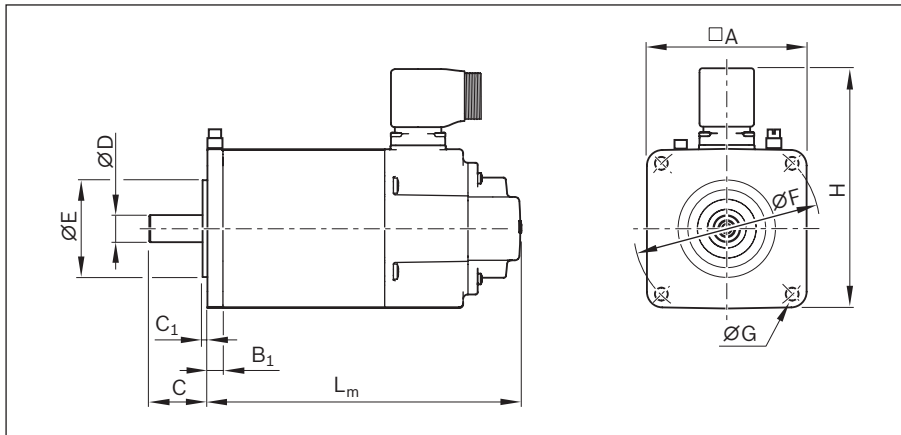

Motor schematic

Dimensions / Motor data

Motor code	Dimensions (mm)										H		L _m	
	A	B ₁	C	C ₁	Ø D _{k6}	Ø E _{j7}	Ø F	Ø G	2	1	without	with		
MS2N03-B0BYN	58	7.5	20	2.5	9	40	63	4.5	84	99	163	192		
MS2N03-D0BYN	58	7.5	23	2.5	11	40	63	4.5	84	99	203	232		
MS2N04-B0BTN	82	8	30	2.5	14	50	95	6.6	108	123	162	194.5		
MS2N04-C0BTN	82	8	30	2.5	14	50	95	6.6	108	123	194	226.5		
MS2N04-D0BQN	82	8	30	2.5	14	50	95	6.6	108	123	226	258.5		
MS2N05-B0BTN	98	9	40	3	19	95	115	9	124	139	188	218		
MS2N05-C0BTN	98	9	40	3	19	95	115	9	124	139	224	254		
MS2N05-D0BRN	98	9	40	3	19	95	115	9	124	139	260	290		

Version

- ▶ Plain shaft without shaft seal ring
- ▶ Multi-turn encoder
- ▶ Standard encoder (B) in conjunction with 2-cable connector (HIPERFACE interface)
- ▶ Advanced encoder (B) in conjunction with 1-cable connector (AcuroLink interface)
- ▶ IP64 rating
- ▶ With or without holding brake
- ▶ Special ground connection terminal near motor flange (used as needed)

Motors are available with control units and controllers. You can find more information on motors and control systems in the Rexroth catalogs on drive technology at www.boschrexroth.com/mediadirectory.

Motor data									Motor connection	Brake	Type code	Part number
n_{max} (min ⁻¹)	M_0 (Nm)	M_{max} (Nm)	M_{br} (Nm)	J_m (kgm ²)	J_{br} (kgm ²)	m_m (kg)	m_{br} (kg)					
9,000	0.73	3.46	1.8	0.000023	0.000007	2.0	0.4	2	N	MS2N03-B0BYN-BMDH0-NNNNE-NN	R911384765	
								2	Y	MS2N03-B0BYN-BMDH1-NNNNE-NN	R911384766	
								1	N	MS2N03-B0BYN-CMSH0-NNNNE-NN	R911384767	
								1	Y	MS2N03-B0BYN-CMSH1-NNNNE-NN	R911384769	
9,000	1.15	6.8	1.8	0.000037	0.000007	2.0	0.4	2	N	MS2N03-D0BYN-BMDH0-NNNNE-NN	R911384770	
								2	Y	MS2N03-D0BYN-BMDH1-NNNNE-NN	R911384771	
								1	N	MS2N03-D0BYN-CMSH0-NNNNE-NN	R911384772	
								1	Y	MS2N03-D0BYN-CMSH1-NNNNE-NN	R911384773	
6,000	1.75	5.9	5.0	0.000070	0.000040	2.7	0.7	2	N	MS2N04-B0BTN-BMDH0-NNNNE-NN	R911384525	
								2	Y	MS2N04-B0BTN-BMDH1-NNNNE-NN	R911384526	
								1	N	MS2N04-B0BTN-CMSH0-NNNNE-NN	R911384527	
								1	Y	MS2N04-B0BTN-CMSH1-NNNNE-NN	R911384528	
6,000	2.80	12.0	5.0	0.000110	0.000050	3.7	0.7	2	N	MS2N04-C0BTN-BMDH0-NNNNE-NN	R911384529	
								2	Y	MS2N04-C0BTN-BMDH1-NNNNE-NN	R911384530	
								1	N	MS2N04-C0BTN-CMSH0-NNNNE-NN	R911384531	
								1	Y	MS2N04-C0BTN-CMSH1-NNNNE-NN	R911384532	
6,000	3.85	18.1	5.0	0.000160	0.000040	4.7	0.7	2	N	MS2N04-D0BQN-BMDH0-NNNNE-NN	R911384533	
								2	Y	MS2N04-D0BQN-BMDH1-NNNNE-NN	R911384534	
								1	N	MS2N04-D0BQN-CMSH0-NNNNE-NN	R911384535	
								1	Y	MS2N04-D0BQN-CMSH1-NNNNE-NN	R911384536	
6,000	3.75	10.6	10.0	0.000170	0.000110	4.0	1.1	2	N	MS2N05-B0BTN-BMDH0-NNNNE-NN	R911384539	
								2	Y	MS2N05-B0BTN-BMDH1-NNNNE-NN	R911384540	
								1	N	MS2N05-B0BTN-CMSH0-NNNNE-NN	R911384542	
								1	Y	MS2N05-B0BTN-CMSH1-NNNNE-NN	R911384543	
6,000	6.10	20.8	10.0	0.000290	0.000110	5.9	1.1	2	N	MS2N05-C0BTN-BMDH0-NNNNE-NN	R911384544	
								2	Y	MS2N05-C0BTN-BMDH1-NNNNE-NN	R911384545	
								1	N	MS2N05-C0BTN-CMSH0-NNNNE-NN	R911384546	
								1	Y	MS2N05-C0BTN-CMSH1-NNNNE-NN	R911384547	
6,000	7.90	31.3	10.0	0.000400	0.000110	7.3	1.1	2	N	MS2N05-D0BRN-BMDH0-NNNNE-NN	R911384548	
								2	Y	MS2N05-D0BRN-BMDH1-NNNNE-NN	R911384549	
								1	N	MS2N05-D0BRN-CMSH0-NNNNE-NN	R911384550	
								1	Y	MS2N05-D0BRN-CMSH1-NNNNE-NN	R911384551	

Dimensions / Motor data

Motor code	Dimensions (mm)											
	A	B ₁	C	C ₁	∅ D _{k6}	∅ E _{j7}	∅ F	∅ G	H		L _m	
									2	Cable 1	without	Brake with
MS2N06-B1BNN	116	14	50	3	24	95	130	9	156	156	164	201
MS2N06-C0BTN	116	14	50	3	24	95	130	9	156	156	184	202
MS2N06-D0BRN	116	14	50	3	24	95	130	9	156	156	224	261
MS2N06-D1BNN	116	14	50	3	24	95	130	9	156	156	224	261
MS2N06-E0BRN	116	14	50	3	24	95	130	9	156	156	264	301
MS2N07-B1BNN	140	18	58	4	32	130	165	11	180	180	176	230
MS2N07-C0BQN	140	18	58	4	32	130	165	11	180	180	205	259
MS2N07-C1BRN	140	18	58	4	32	130	165	11	180	180	205	259
MS2N07-D0BRN	140	18	58	4	32	130	165	11	180	180	263	317
MS2N07-D1BNN	140	18	58	4	32	130	165	11	180	180	263	317
MS2N07-E1BNN	140	18	58	4	32	130	165	11	180	180	321	375

Motor data									Motor connection	Brake	Type code	Part number
n_{max} (min ⁻¹)	M_0 (Nm)	M_{max} (Nm)	M_{br} (Nm)	J_m (kgm ²)	J_{br} (kgm ²)	m_m (kg)	m_{br} (kg)					
6,000	3.25	9.5	10.0	0.000480	0.0001100	5.1	1.1	2	N	MS2N06-B1BNN-BMUH0-NNNNE-NN	R911384927	
								2	Y	MS2N06-B1BNN-BMUH1-NNNNE-NN	R911384928	
								1	N	MS2N06-B1BNN-CMSH0-NNNNE-NN	R911384929	
								1	Y	MS2N06-B1BNN-CMSH1-NNNNE-NN	R911384930	
6,000	6.00	16.0	10.0	0.000390	0.0001100	6.4	1.0	2	N	MS2N06-C0BTN-BMUH0-NNNNE-NN	R911384931	
								2	Y	MS2N06-C0BTN-BMUH1-NNNNE-NN	R911384932	
								1	N	MS2N06-C0BTN-CMSH0-NNNNE-NN	R911384933	
								1	Y	MS2N06-C0BTN-CMSH1-NNNNE-NN	R911384934	
6,000	9.70	32.0	15.0	0.000650	0.0001400	9.0	1.5	2	N	MS2N06-D0BRN-BMUH0-NNNNE-NN	R911384935	
								2	Y	MS2N06-D0BRN-BMUH2-NNNNE-NN	R911384936	
								1	N	MS2N06-D0BRN-CMSH0-NNNNE-NN	R911384937	
								1	Y	MS2N06-D0BRN-CMSH2-NNNNE-NN	R911384938	
6,000	9.00	38.4	15.0	0.001400	0.0001400	9.0	1.5	2	N	MS2N06-D1BNN-BMUH0-NNNNE-NN	R911384939	
								2	Y	MS2N06-D1BNN-BMUH2-NNNNE-NN	R911384940	
								1	N	MS2N06-D1BNN-CMSH0-NNNNE-NN	R911384941	
								1	Y	MS2N06-D1BNN-CMSH2-NNNNE-NN	R911384942	
6,000	13.0	49.0	15.0	0.000890	0.0001400	11.5	1.5	2	N	MS2N06-E0BRN-BMUH0-NNNNE-NN	R911384943	
								2	Y	MS2N06-E0BRN-BMUH2-NNNNE-NN	R911384944	
								1	N	MS2N06-E0BRN-CMSH0-NNNNE-NN	R911384945	
								1	Y	MS2N06-E0BRN-CMSH2-NNNNE-NN	R911384946	
6,000	7.40	21.0	20.0	0.001970	0.0002600	9.5	2.0	2	N	MS2N07-B1BNN-BMUH0-NNNNE-NN	R911384949	
								2	Y	MS2N07-B1BNN-BMUH1-NNNNE-NN	R911384950	
								1	N	MS2N07-B1BNN-CMSH0-NNNNE-NN	R911384951	
								1	Y	MS2N07-B1BNN-CMSH1-NNNNE-NN	R911384952	
6,000	12.8	35.7	20.0	0.001200	0.0002600	12.0	2.0	2	N	MS2N07-C0BQN-BMUH0-NNNNE-NN	R911384953	
								2	Y	MS2N07-C0BQN-BMUH1-NNNNE-NN	R911384954	
								1	N	MS2N07-C0BQN-CMSH0-NNNNE-NN	R911384955	
								1	Y	MS2N07-C0BQN-CMSH1-NNNNE-NN	R911384956	
6,000	11.50	42.2	20.0	0.003050	0.0002600	12.0	2.0	2	N	MS2N07-C1BRN-BMUH0-NNNNE-NN	R911384957	
								2	Y	MS2N07-C1BRN-BMUH1-NNNNE-NN	R911384958	
								1	N	MS2N07-C1BRN-CMSH0-NNNNE-NN	R911384959	
								1	Y	MS2N07-C1BRN-CMSH1-NNNNE-NN	R911384960	
6,000	22.0	73.2	36.0	0.002100	0.0004100	17.5	2.5	2	N	MS2N07-D0BRN-BMVH0-NNNNE-NN	R911384961	
								2	Y	MS2N07-D0BRN-BMVH2-NNNNE-NN	R911384962	
6,000	18.90	84.8	36.0	0.005290	0.0004100	17.5	2.5	2	N	MS2N07-D1BNN-BMUH0-NNNNE-NN	R911384963	
								2	Y	MS2N07-D1BNN-BMUH2-NNNNE-NN	R911384964	
								1	N	MS2N07-D1BNN-CMSH0-NNNNE-NN	R911384965	
								1	Y	MS2N07-D1BNN-CMSH2-NNNNE-NN	R911384966	
6,000	25.8	128.5	36.0	0.007520	0.0000410	23.0	3.0	2	N	MS2N07-E1BNN-BMVH0-NNNNE-NN	R911384969	
								2	Y	MS2N07-E1BNN-BMVH2-NNNNE-NN	R911384970	

Switching system

Overview of attachment variants

Magnetic sensor with free cable end

- 1 Socket and plug
- 2 Sensor
- 3 Mounting channel

Alternatively, the sensor can also be attached by switch mounting plate and cable holder.

See the magnetic sensor with plug.

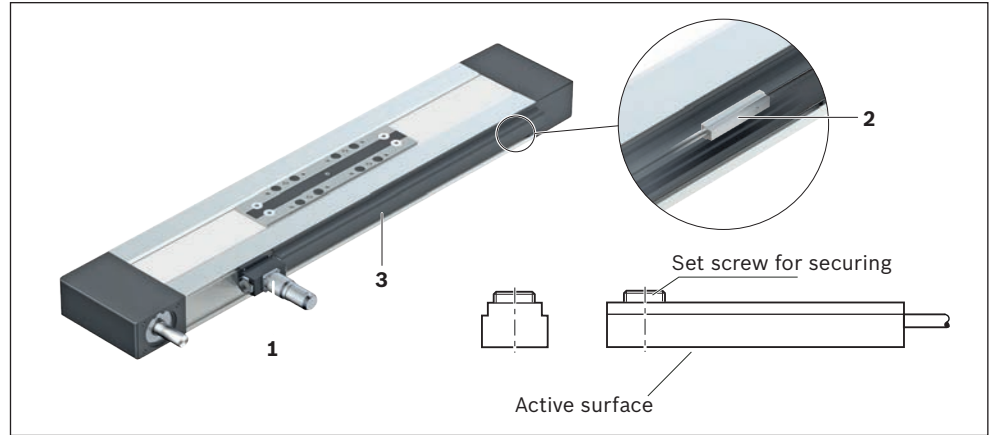

Attachment/actuation

A mounting duct is needed to fasten the sensors and cable guides. This is suspended at the side in a slot at the Compact Modules and secured with set screws (4).

The set screws are included. The sensors are pushed into the upper T-slot (CKK/CKR-090,-110 and CKK-145) or into the lower T-slot (CKR-145, CKK/CKR-200) of the mounting duct and secured with set screws.

Switch activation is done by magnets in the carriage.

CKK/CKR-070	CKK/CKR-090 CKK/CKR-110 CKK-145	CKR-145	CKK/CKR-200

Mounting channel

Compact Modules	Part number	Length calculation
CKK/CKR: 070	R039662026	$L_K = L - 5$
CKK: 090, 110, 145, 200	R039662018	$L_K = L - 5$
CKR: 090, 110, 145, 200	R039662018	$L_K = L - 10$

L_K = Length of the fastening duct (mm)
 L = Length of the linear motion system (mm)

Socket - plug

Notes:

The socket and plug are not pre-wired. This allows optimal assignment of switching positions during start-up.

One plug is included.

The plug can be mounted in three directions.

For further information, see the section "Socket - plug".

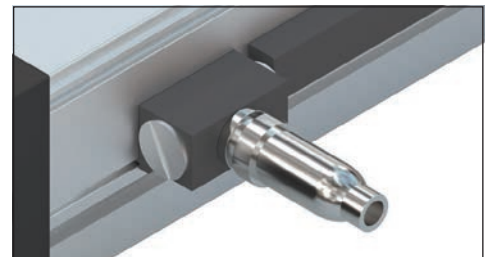
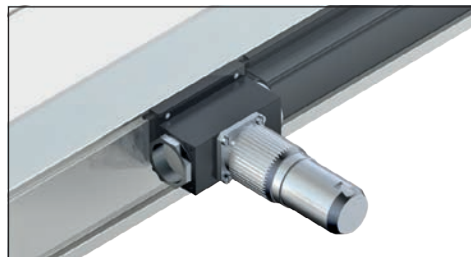

Socket-plug	
Compact Modules	Part number
CKK/CKR: 070	R117560102
CKK/CKR: 090, 110, 145	R037540000

Socket-plug	
Compact Modules	Part number
CKK/CKR: 200	R037540000

Magnetic sensor with plug

- 1 Sensor
- 2 Switch mounting plate including set screws (loose) and square nut (2a)
- 3 Cable holder including set screw (loose)

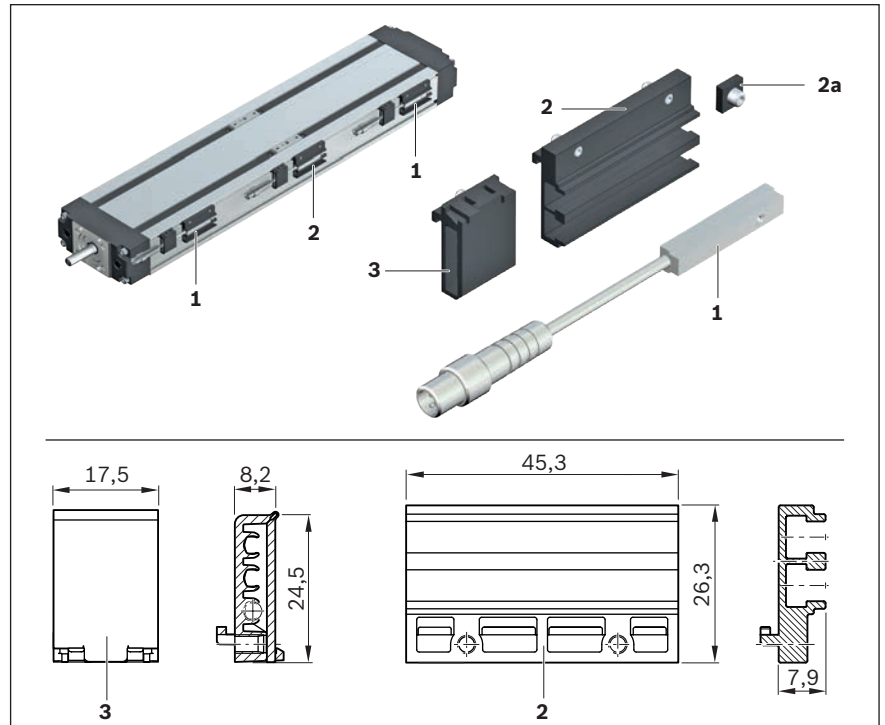

Attachment/actuation

A switch mounting plate (2) is required to attach the sensors. This is suspended in the slot on the Compact Modules and secured with set screws (4).

The sensors are pushed into the respective slot on the switch mounting plate and secured with one set screw.

The square nut with set screw (2a) serves as a positive stop for the sensor (switching position when changing sensors).

Parts are included with the sensor mounting kit.

Switch activation is done by magnets in the carriage.

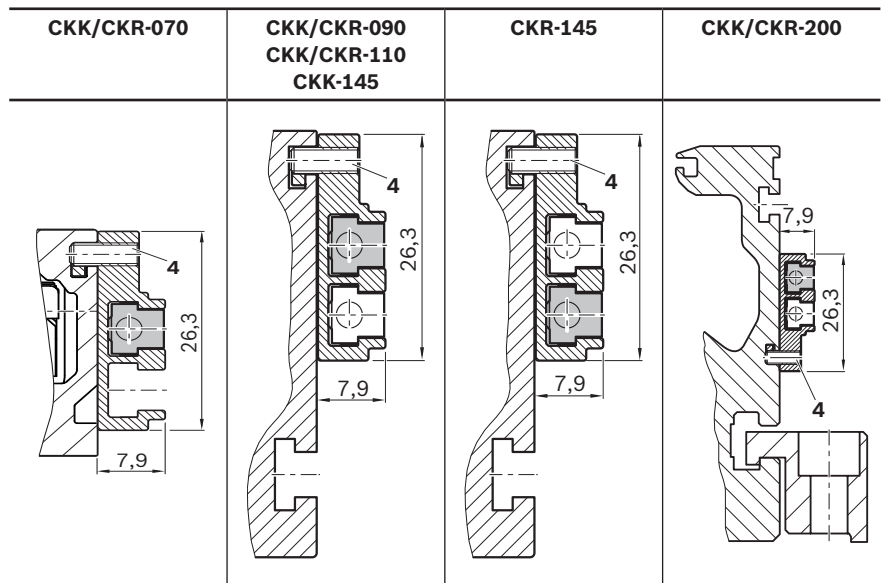

Switches and attachments

Item	Part number
1 Magnetic sensor with plug	See the chapter on sensors and accessories
2 Switch mounting plate	R037530021
3 Cable holder	R037530022

**Inductive sensors and mechanical switches for
CKK/CKR-200**

- 1 Socket and plug
- 2 Mechanical switch
(with additional components)
- 3 Inductive sensor
(with additional components)
- 4 Switching cam
(attachment only at the connection plate)
- 5 Cable duct

Alternatively, the connection line of the sensor can also be attached by cable holder. See "Switching system".

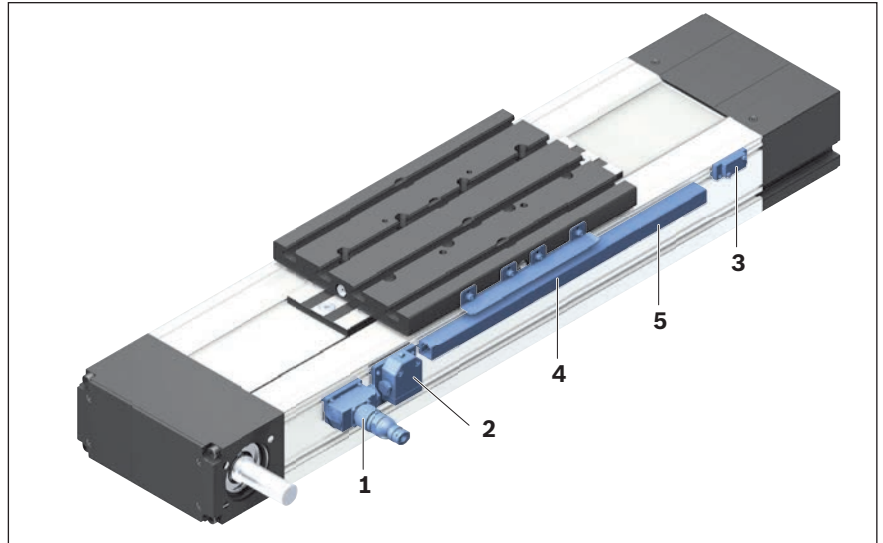

Attachment/actuation

The switches are suspended in the upper slot on the Compact Modules and secured with set screws (6).

The actuation is done using switching cams (4). This is attached with the screws to the connection plate. Fastening screws are included.

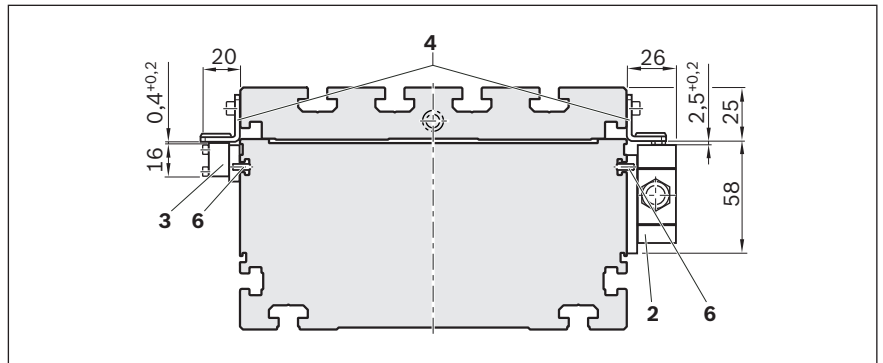

Switch with additional component

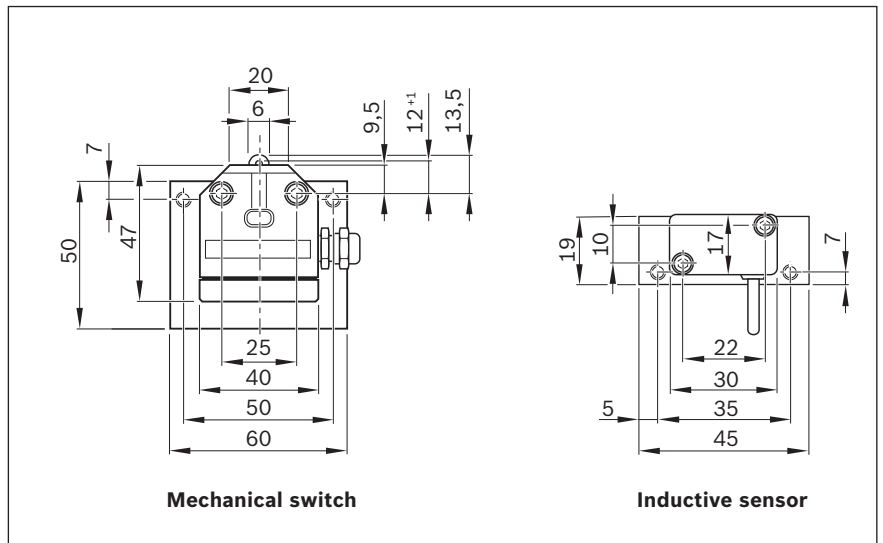

Cable duct

The attachment is done in the lateral slots of the frame. Fastening screws widen the profile and ensure that the cable duct is securely mounted.

The cable duct will accommodate up to two cables for mechanical switches and three cables for proximity switches.

Fastening screws are included.

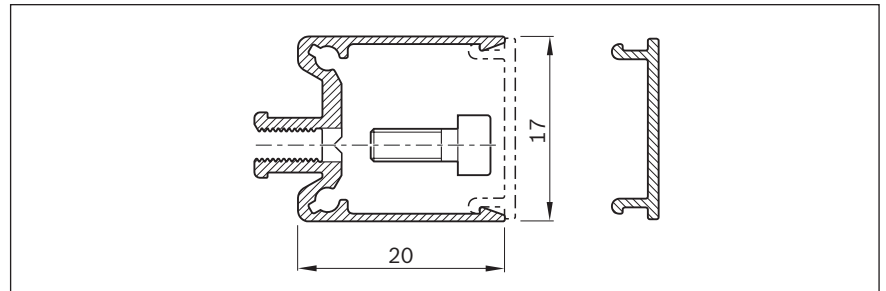

Cable duct

Compact Modules	Length calculation
CKK 200	$L_K = L - 5$
CKR 200	$L_K = L - 10$

L_K = Length of the fastening and the cable duct (mm)
 L = Length of the linear motion system (mm)

Socket - plug

Notes:

The socket and plug are not pre-wired.

This allows optimal assignment of switching positions during start-up.

One plug is included.

The plug can be mounted in three directions.

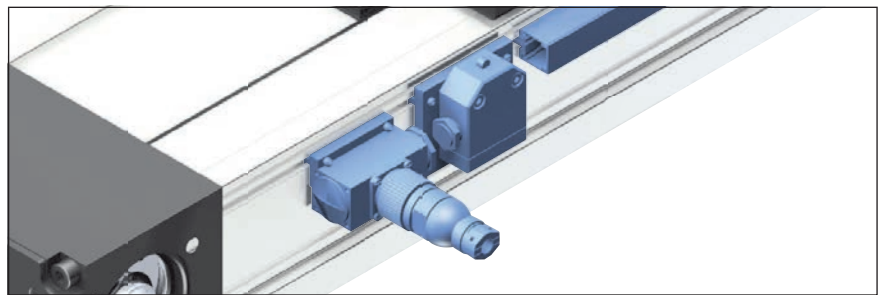

Switches and attachments

Item		Part numbers
1	Socket-plug	R117500153
2	Mechanical switch	See the chapter on sensors and accessories
	- Attachment parts without switch	R117500165
3	Inductive sensor	See the chapter on sensors and accessories
	- Attachment parts without sensor	R117500152
4	Switching angle¹⁾	R117500150
5	Cable duct $L_K = XX$ mm	R039662017

¹⁾ Size 200 switching angle attachment is only possible on connection plate – otherwise customer-designed solution.

Sensors

Magnetic sensor with free cable end

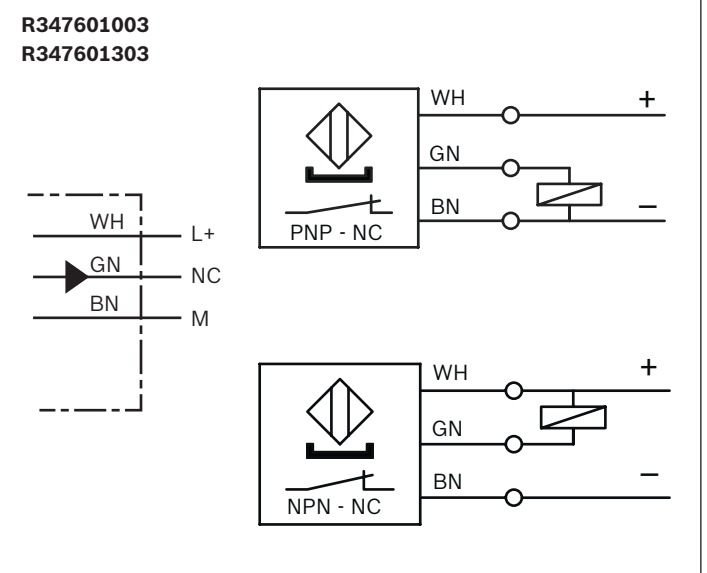
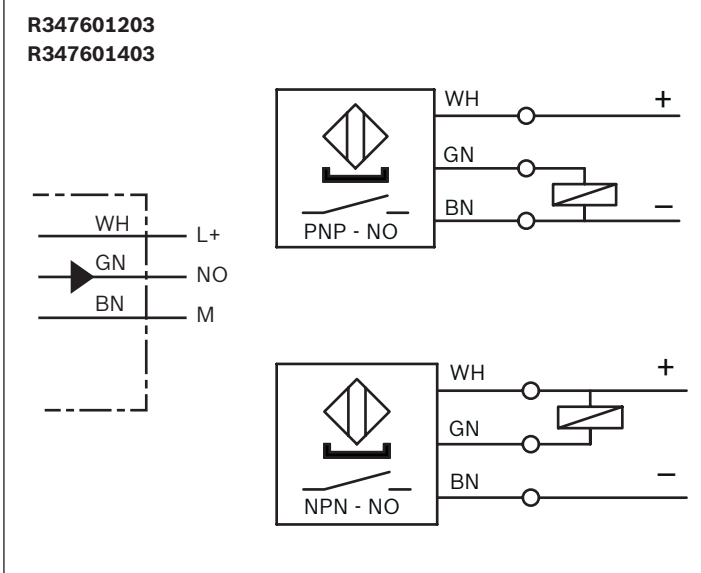
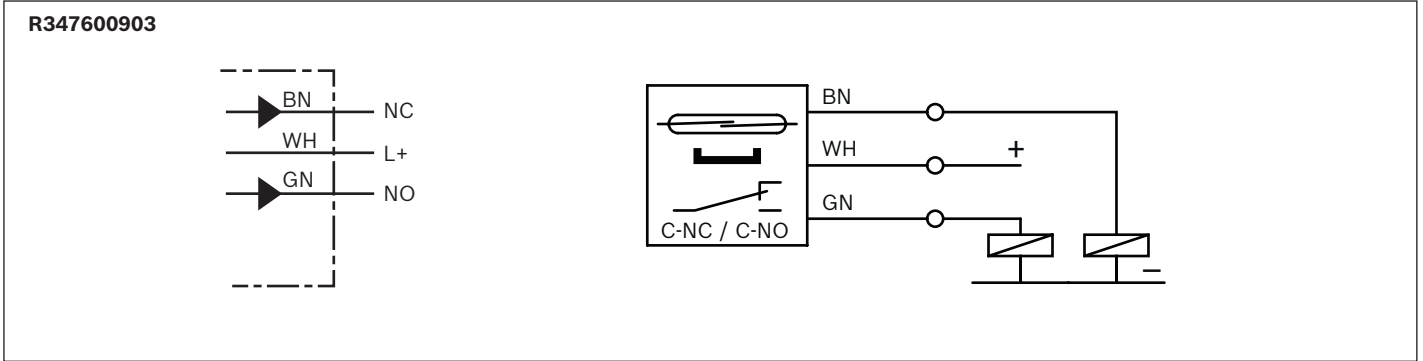
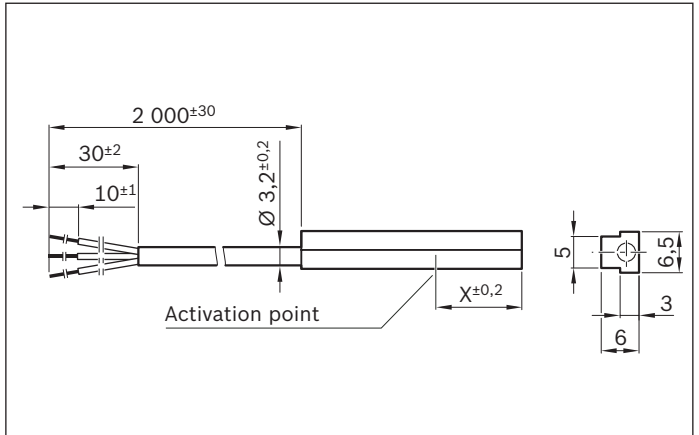
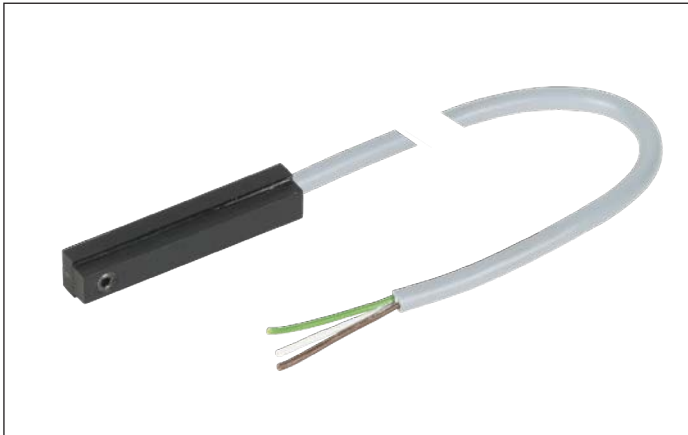

Part number R347600903

Use	Reference, limit switch
Part number	R347600903
Designation	R12212
Functional principle	magnetic
Operating voltage	max. 30 V DC
Load current	500 mA
Switching function	REED/changeover contact: (NC: C+NC, NO: C+NO)
Activation point (dimension "X")	9 mm

Part number R347601003 / R347601203 / R347601403 / R347601303

Use	Limit switch	Reference switch	Limit switch	Reference switch
Part number	R347601003	R347601203	R347601303	R347601403
Designation	H14118	H15637	H15638	H15080
Functional principle	magnetic			
Operating voltage	3.8 - 30 V DC			
Load current	≤ 20 mA			
Switching function	Hall PNP/NC	Hall PNP/NO	Hall NPN/NC	Hall NPN/NO
Activation point dimension "X"	13.65 mm			

Technical data for R347600903 / R347601003 / R347601203 / R347601403 / R347601303

Connection type	Cable 2.0 m, 3-pin
Galvanized connection ends	4
Function indicator	—
Short-circuit protection	—
Reverse polarity protection	—
Switch-on suppression	—
Switching frequency	2.5 kHz
Pulse elongation (off delay)	—
Max. permissible starting speed	2 m/s
Suitable for drag chains¹⁾	—
Torsion-resistant¹⁾	—
Welding spark-resistant*	—
Cable cross-section*	3 x 0.14 mm ²
Cable diameter D	3.2 ±0.20 mm
Static bending radius¹⁾	—
Dynamic bending radius¹⁾	—
Bending cycles¹⁾	—
Maximum permissible travel speed¹⁾	—
Max. permissible acceleration¹⁾	—
Ambient temperature	-40 °C to +85 °C
IP rating	IP66
MTTFd (per EN ISO 13849-1)	—
Certifications and approvals²⁾	—

¹⁾ Technical data only for the cast-on connection line at the sensor.

The available extension cables offer even better performance, e.g., when using a power cable chain (see following pages).

²⁾ No (CCC) certificate is required to introduce these products to the Chinese market.

Magnetic sensor with M8x1 plug

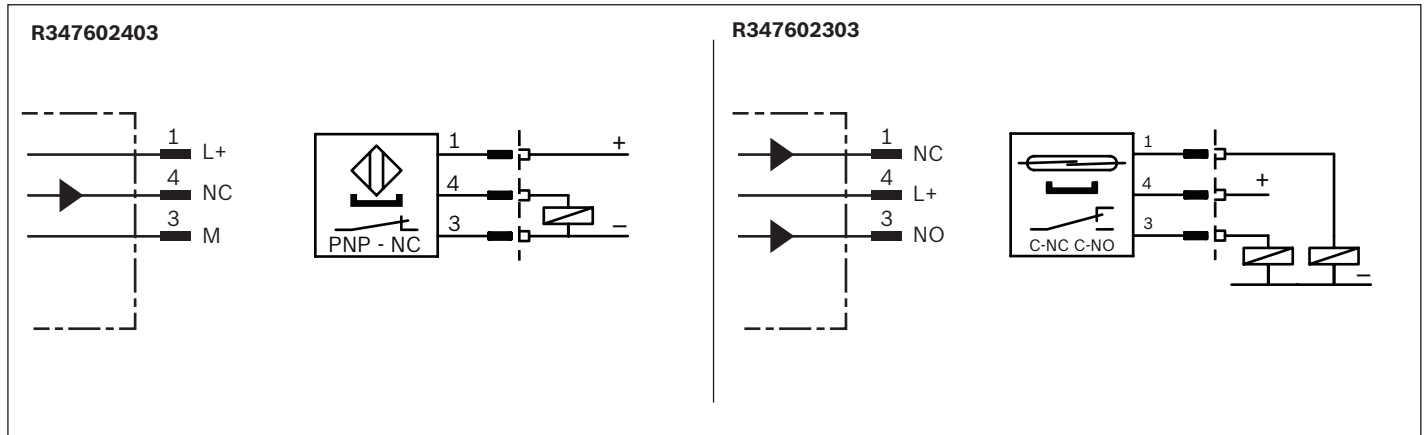
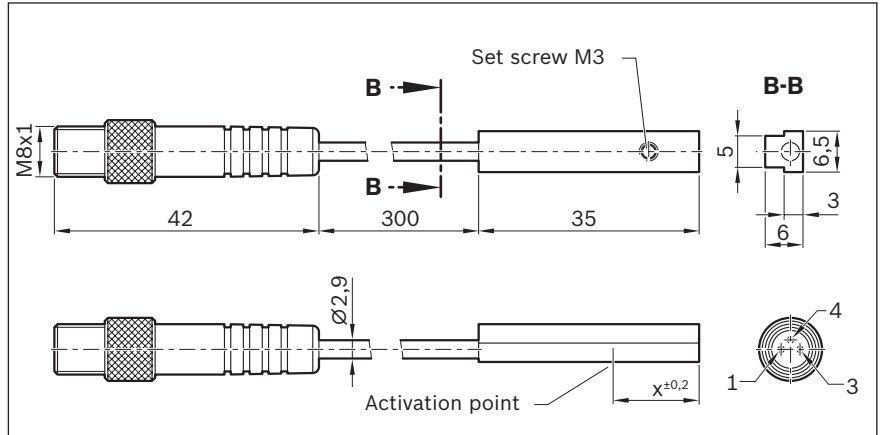

Part numbers/technical data

Use	Reference / limit switch	Limit switch
Part number	R347602403	R347602303
Designation	H10706	R10705
Functional principle	magnetic	
Operating voltage	3.8 - 30 V DC	30 V DC
Load current	≤ 20 mA	500 mA
Switching function	Hall PNP/NC	REED/single-pole changeover (NC: C+NC, NO: C+NO)
Activation point dimension "X"	13.65 mm	9 mm
Connection type	0.3 m cable and M8x1 connector, 3-pin with knurled screw connection	
Function indicator	—	
Short-circuit protection	—	
Reverse polarity protection	—	
Switch-on suppression	—	
Switching frequency	2.5 kHz	
Pulse elongation (off delay)	—	
Max. permissible starting speed	2 m/s	
Suitable for drag chains¹⁾	—	
Torsion-resistant¹⁾	—	
Weld spark-resistant¹⁾	—	
Cable cross-section¹⁾	3 x 0.14 mm ²	
Cable diameter D¹⁾	3.2 ±0.20 mm	
Static bending radius¹⁾	—	
Dynamic bending radius¹⁾	—	
Bending cycles¹⁾	—	
Maximum permissible travel speed¹⁾	—	
Max. permissible acceleration¹⁾	—	
Ambient temperature	-40 °C to +85 °C	
IP rating	IP66	
MTTFd (per EN ISO 13849-1)	—	
Certifications and approvals²⁾	—	

¹⁾ Technical data only for the cast-on connection line at the sensor.

The available extension cables offer even better performance, e.g., when using a power cable chain (see following pages).

²⁾ No (CCC) certificate is required to introduce these products to the Chinese market.

Inductive sensor with free line end

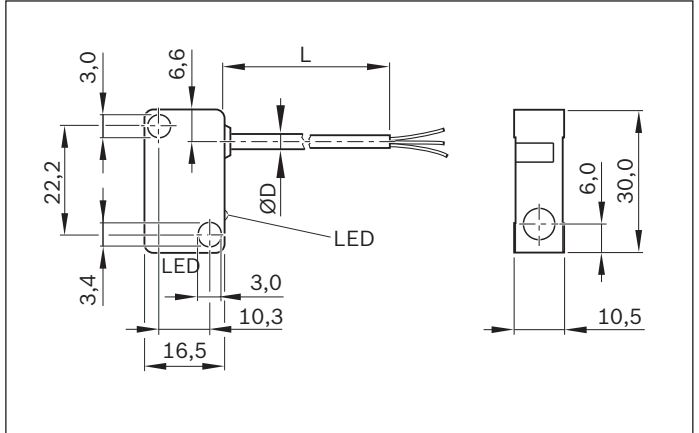
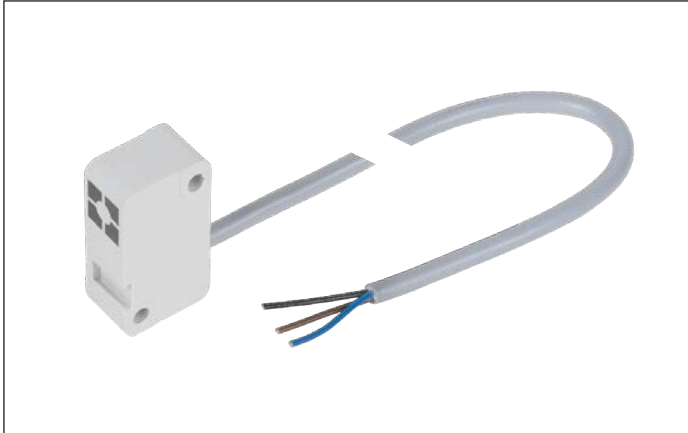

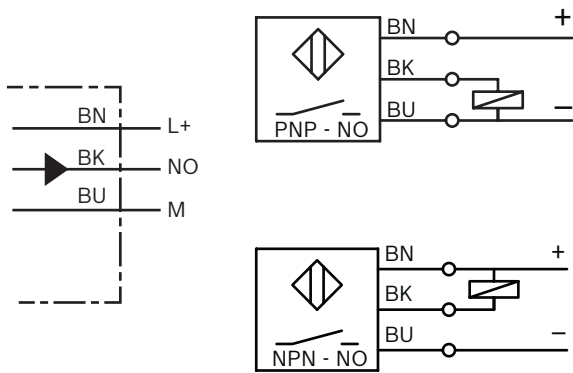

R345304003
R345304004

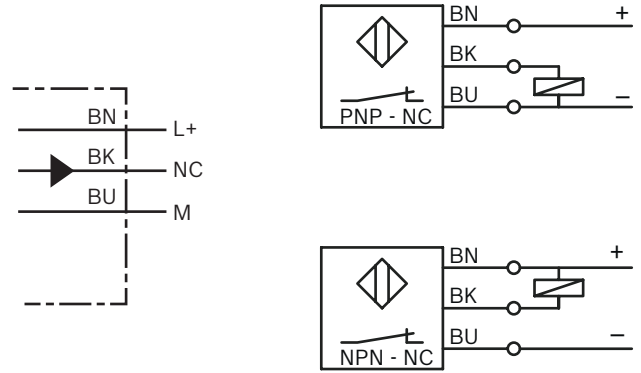

R345304001
R345304002



Part numbers/technical data

Use	Limit switch	Reference switch	Limit switch	Reference switch
Part number	R345304001	R345304003	R345304002	R345304004
Designation	BES 517-351-NO-C-03	BES 517-398-NO-C-03	BES 517-352-NO-C-03	BES 517-399-NO-C-03
Functional principle	inductive			
Operating voltage	10–30 V DC			
Load current	≤ 200 mA			
Switching function	PNP/NC	PNP/NO	NPN/NC	NPN/NO
Connection type	Line 3 m, 3-pin, free line end			
Function indicator	✓			
Short-circuit protection	✓			
Reverse polarity protection	✓			
Switching frequency	2.5 kHz			
Max. perm. starting speed	depending on the switching cam			
Suitable for drag chains¹⁾	–			
Torsion-resistant¹⁾	–			
Weld spark-resistant¹⁾	–			
Cable cross-section¹⁾	3 x 0.14 mm ²			
Cable diameter D¹⁾	3.5 ±0.15 mm			
Static bending radius¹⁾	12 mm			
Dynamic bending radius¹⁾	12 mm			
Bending cycles¹⁾	–			
Ambient temperature	-40 °C to +70 °C			
IP rating	IP65			
MTTFd (acc. to EN ISO 13849-1)	MTTFd = 830 years		MTTFd = 585 years	
Certifications and approvals²⁾	  			

¹⁾ Technical data only for the cast-on connection line at the sensor.



The available extension cables offer even better performance, e.g., when using a power cable chain (see following pages).

²⁾ No  certificate is required to introduce these products to the Chinese market.

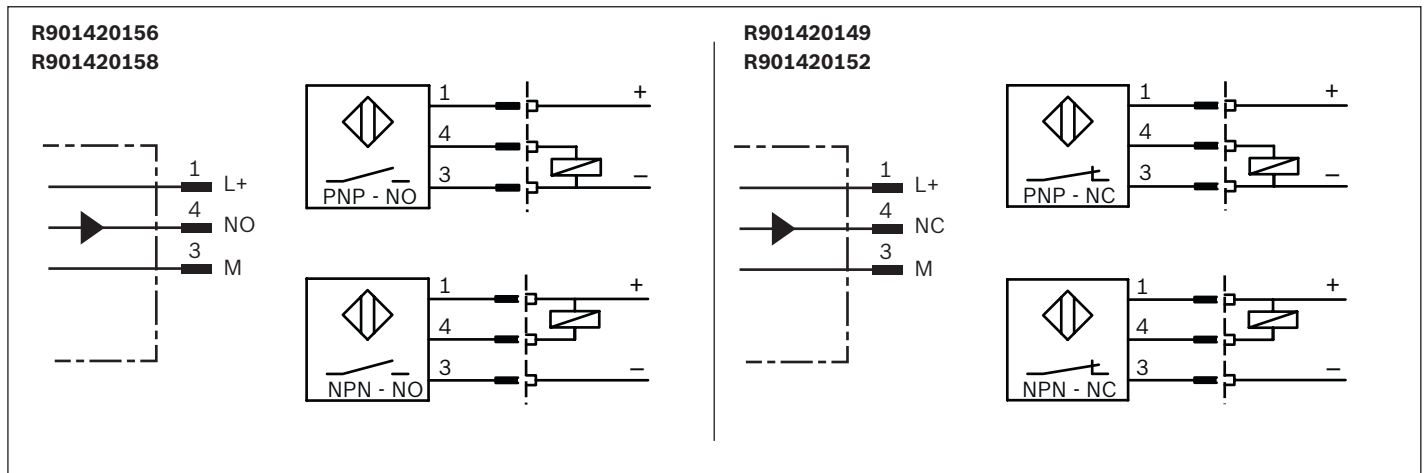
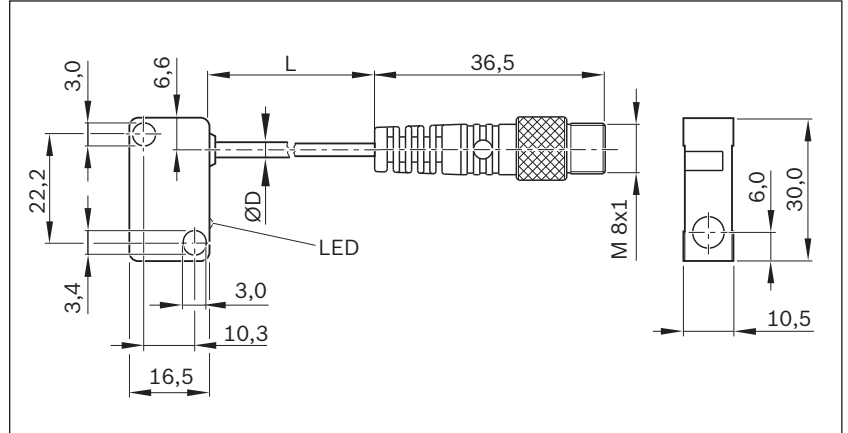
Inductive sensor with M8x1 plug











Part numbers/technical data

Use	Limit switch	Reference switch	Limit switch	Reference switch
Part number	R901420149	R901420156	R901420152	R901420158
Designation	BES 517-351-NO-C-S49-00.2	BES 517-398-NO-C-S49-00.2	BES 517-352-NO-C-S49-00.2	BES 517-399-NO-C-S49-00.2
Functional principle	inductive			
Operating voltage	10–30 V DC			
Load current	≤ 200 mA			
Switching function	PNP/NC	PNP/NO	NPN/NC	NPN/NO
Connection type	Cable 0.2 m and plug M8 x 1, 3-pin with knurled screw			
Function indicator	✓			
Short-circuit protection	✓			
Reverse polarity protection	✓			
Switching frequency	2.5 kHz			
Max. permissible starting speed	depending on the switching cam			
Suitable for drag chains¹⁾	–			
Torsion-resistant¹⁾	–			
Weld spark-resistant¹⁾	–			
Cable cross-section¹⁾	3x0.14 mm ²			
Cable diameter D¹⁾	3.5 ±0.15 mm			
Static bending radius¹⁾	12 mm			
Dynamic bending radius¹⁾	12 mm			
Bending cycles¹⁾	–			
Ambient temperature	-40 °C to +70 °C			
IP rating	IP65			
MTTFd (per EN ISO 13849-1)	MTTFd = 830 years		MTTFd = 585 years	
Certifications and approvals²⁾	  			

¹⁾ Technical data only for the cast-on connection line at the sensor.

The available extension cables offer even better performance, e.g., when using a power cable chain (see following pages).

²⁾ No  certificate is required to introduce these products to the Chinese market.

Part numbers/technical data	
Use	Limit switch
Part number	R345304016 ¹⁾ R347600305 ²⁾
Designation	BNS 819-X496-99-R-11 BNS 819-X510-99-R-10
Functional principle	mechanical, roller
Operating voltage	250 V AC
Load current	≤ 5 A
Switching function	single-pole changeover/ (NC: C+NC, NO: C+NO)
Connection type	Screw connection, without line
Function indicator	-
Switching frequency	3.3 Hz
Max. permissible starting speed	1 m/s
Ambient temperature	-5°C to +85°C
IP rating	IP67
B10d value	5x10 ⁶ (wet area); 10x10 ⁶ (dependent on current load (dry area))
Certifications and approvals, housing	  
Certifications and approvals, switching element	   

Mechanical switch with M8x1 plug

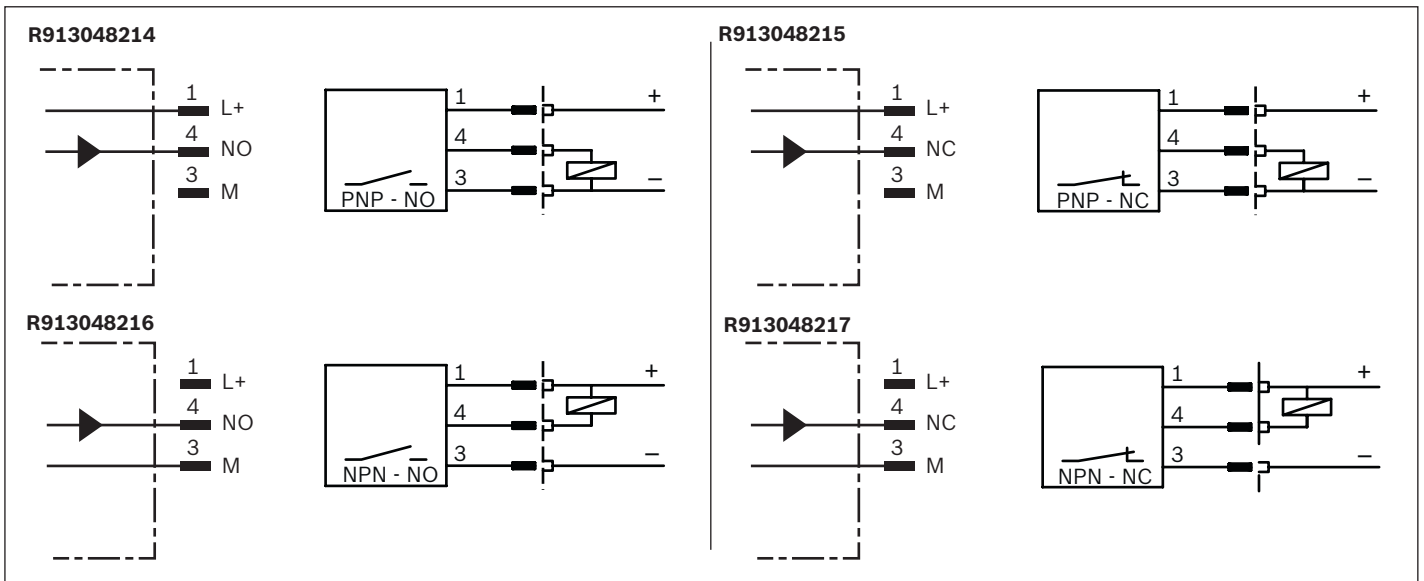
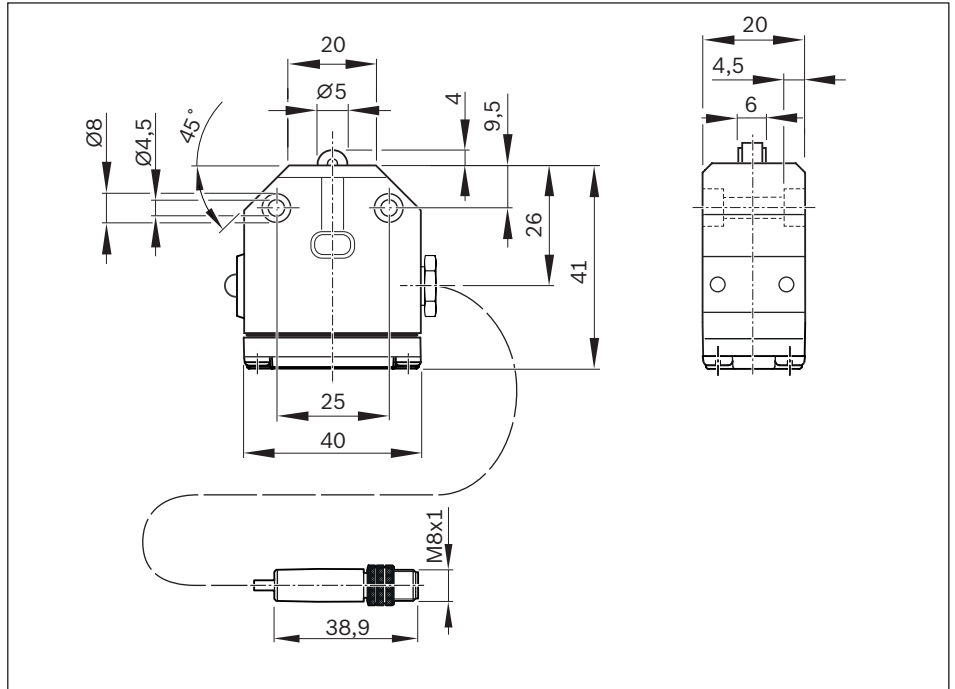

Part numbers/technical data

Use	Limit switch	Reference switch	Limit switch	Reference switch
Part number	R913048215	R913048214	R913048217	R913048216
Designation	BNS 819-X1002-99-R-10	BNS 819-X1001-99-R-10	BNS 819-X1004-99-R-10	BNS 819-X1003-99-R-10
Functional principle	mechanical, roller			
Operating voltage	10 - 30 VDC			
Load current	≤ 200 mA			
Switching function	PNP/NC	PNP/NO	NPN/NC	NPN/NO
Connection type	Cable 0.2 m and plug M8 x 1, 3-pin with knurled screw			
Function indicator	-			
Short-circuit protection	-			
Reverse polarity protection	-			
Switching frequency	3.3 Hz			
Max. perm. starting velocity	1 m/s			
Suitable for drag chains¹⁾	-			
Torsion-resistant¹⁾	-			
Weld spark-resistant¹⁾	-			
Cable cross-section¹⁾	3x0.14 mm ²			
Cable diameter D¹⁾	4.3 ±0.2 mm			
Static bending radius¹⁾	12 mm			
Dynamic bending radius¹⁾	12 mm			
Bending cycles¹⁾	-			
Ambient temperature	-5 °C to +70 °C			
IP rating	IP65			
B10d value	5x10 ⁶ (wet area); 10x10 ⁶ (dependent on current load (dry area))			
Certifications and approvals²⁾				

¹⁾ Technical data only for the cast-on connection line at the mechanical switch.
The available extension cables offer even better performance, e.g., when using a power cable chain (see following pages).
²⁾ No  certificate is required to introduce these products to the Chinese market.

Extensions

Assembled on one end

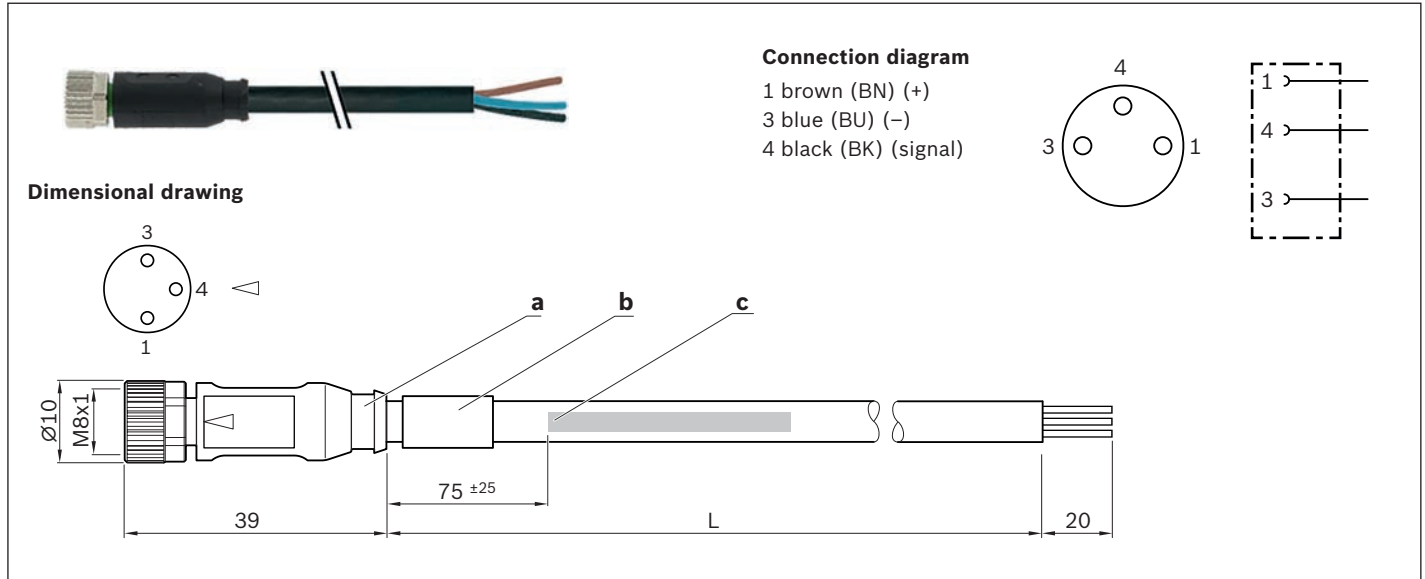

Part numbers

Use	Extension cable		
Part number	R911344602	R911344619	R911344620
Designation	7000-08041-6500500	7000-08041-6501000	7000-08041-6501500
Length (L)	5.0 m	10.0 m	15.0 m
1st connection type	M8x1 3-pin straight female connector		
2nd connection type	Unassembled cable end		

- a) Contour for 6.5 mm corrugated tube (inner diameter)
- b) Cable grommet
- c) Cable printing per printing specification

Assembled on both ends

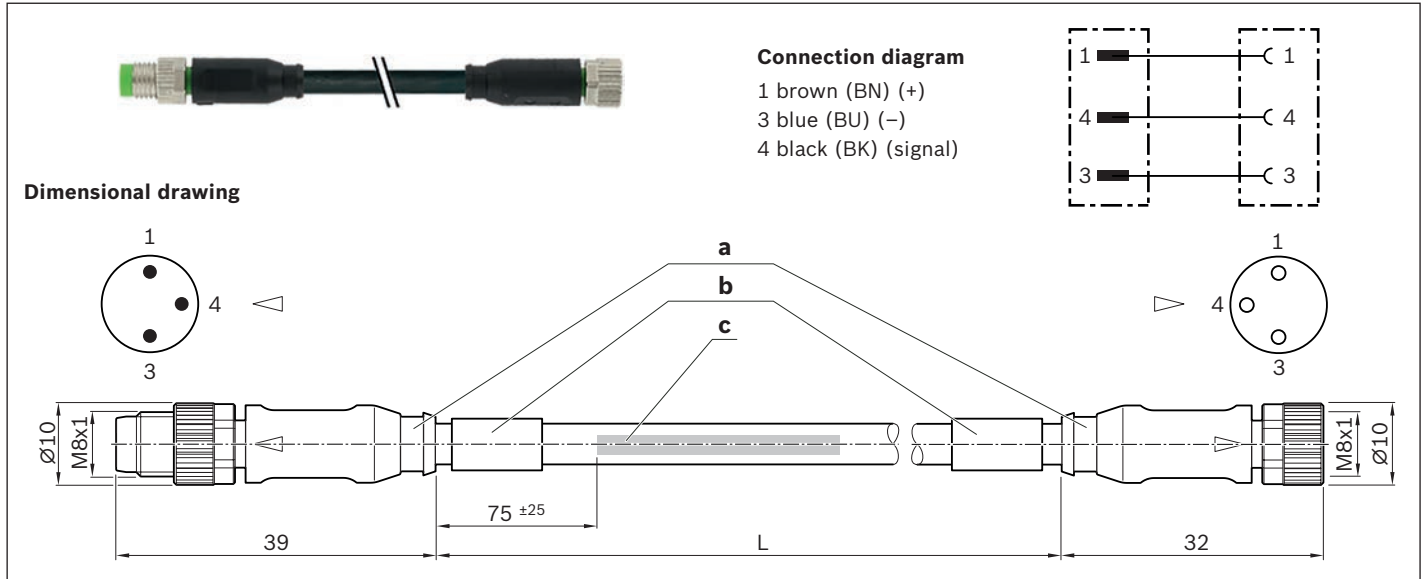

Part numbers

Use	Extension cable				
Part number	R911344621	R911344622	R911344623	R911344624	R911344625
Designation	7000-88001-6500050	7000-88001-6500100	7000-88001-6500200	7000-88001-6500500	7000-88001-6501000
Length (L)	0.5 m	1.0 m	2.0 m	5.0 m	10.0 m
1st connection type	M8x1 3-pole straight female connector				
2nd connection type	Straight plug, M8x1, 3-pin				

Technical data for extensions pre-assembled on one or two sides

Function indicator	-
Operating voltage indicator	-
Operating voltage	10-30 V DC
Type of cable	PUR black
Suitable for drag chains	✓
Torsion-resistant	✓
Weld spark-resistant	✓
Cable cross-section	3x0.25 mm ²
Cable diameter D	4.1 ±0.2 mm
Static bending radius	≥ 5xD
Dynamic bending radius	≥ 10xD
Bending cycles	> 10 mil.
Max. permissible travel velocity	3.3 m/s for 5 m travel distance (typ.), up to 5 m/s for 0.9 m travel distance
Max. permissible acceleration	≤ 30 m/s ²
Ambient temperature fixed ext.	-40°C to +85°C
Ambient temperature flexible ext.	-25°C to +85°C
IP rating	IP68
Certifications and approvals	    



a) Contour for 6.5 mm corrugated tube (inner diameter)
b) Cable grommet

c) Cable printing per printing specification

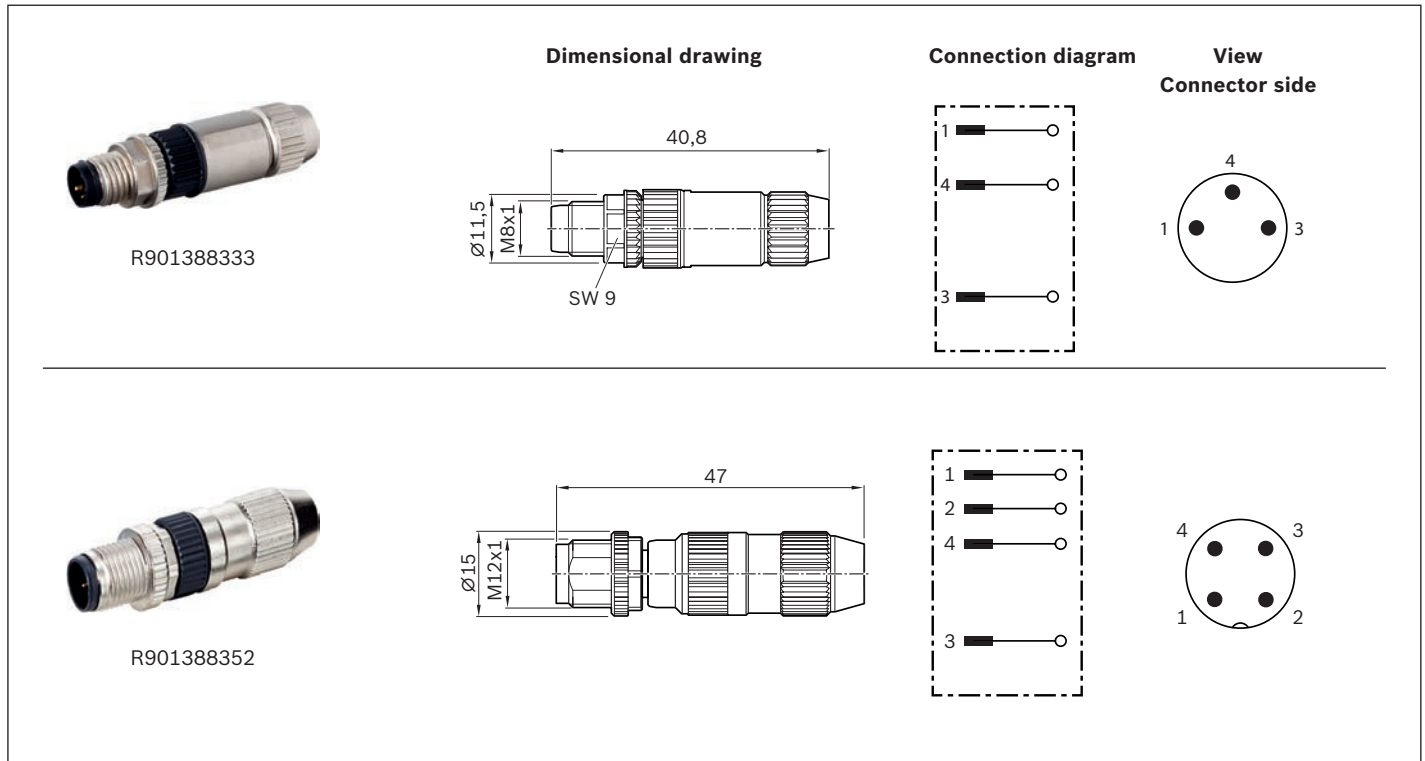
Connectors



Part numbers/technical data

Use	Male connector, single	
Part number	R901388333	R901388352
Designation	7000-08331-0000000	7000-12491-0000000
Version	straight	
Operating current per contact	max. 4 A	
Operating voltage	max. 32 V AC/DC	
Connection type	Male connector, straight, M8x1, 3-pin Insulation displacement, self-locking screw thread	Male connector, straight, M12x1, 4-pin Insulation displacement, self-locking screw thread
Function indicator	-	
Operating voltage indicator	-	
Connection cross-section	0.14 ... 0.34 mm ²	
Ambient temperature	-25°C to +85°C	
IP rating	IP67 (inserted and locked)	
Certifications and approvals	  	

Adapters

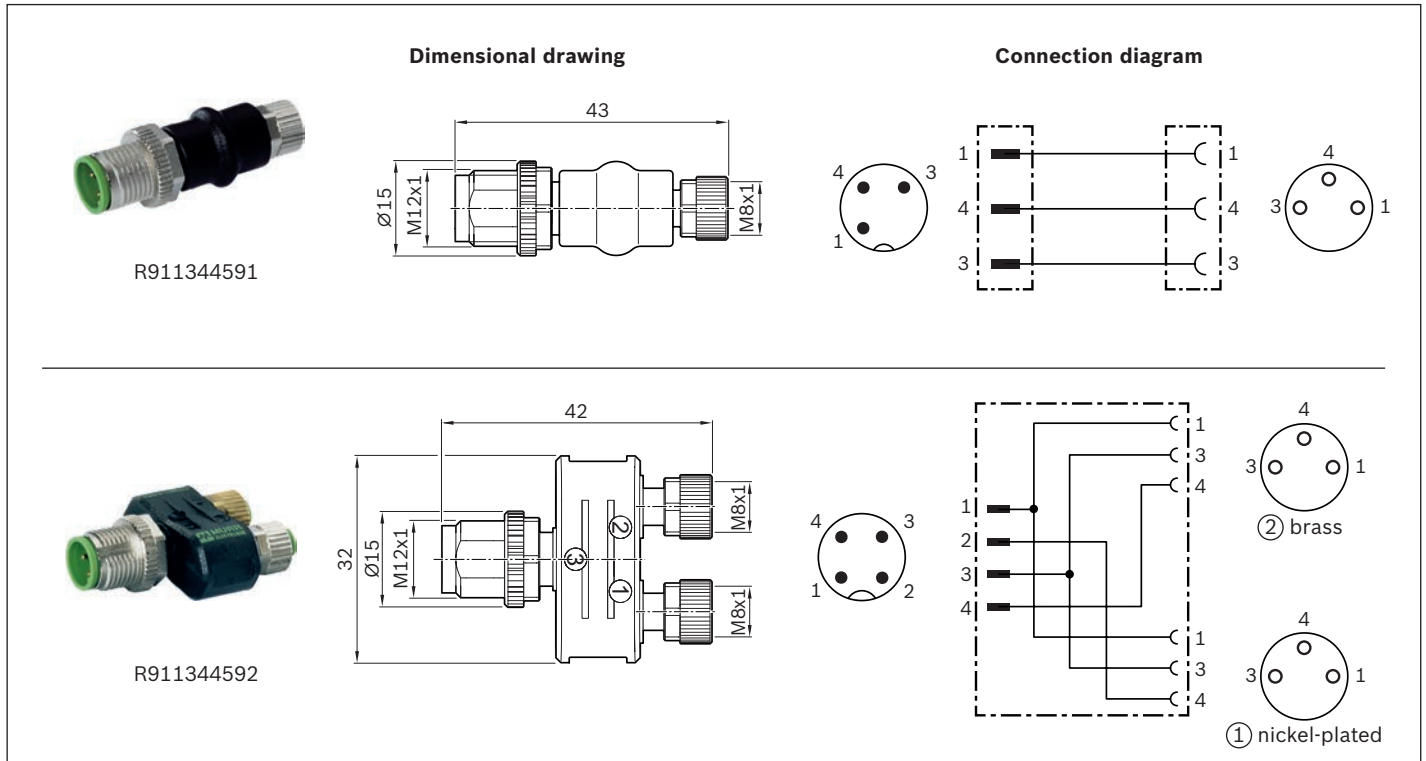

Part numbers/technical data



Use	Adapter	Adapter or distributor
Part number	R911344591	R911344592
Designation	7000-42201-0000000	7000-41211-0000000
Version	straight for 1 sensor	straight, for 1 - 2 sensors
Operating current per contact	max. 4 A	
Operating voltage	max. 32 V AC/DC	
1st connection type	M8x1 3-pole straight female connector self-locking screw thread	2 X straight female connectors, M8x1, 3-pin self-locking screw thread
2nd connection type	Male connector, straight, M12x1, 3-pin, self-locking screw thread	Male connector, straight, M12x1, 4-pin self-locking screw thread
Function indicator	-	
Operating voltage indicator	-	
Connection cross-section	-	
Ambient temperature	-25°C to +85°C	
IP rating	IP67 (inserted and locked)	
Certifications and approvals		

Distributors

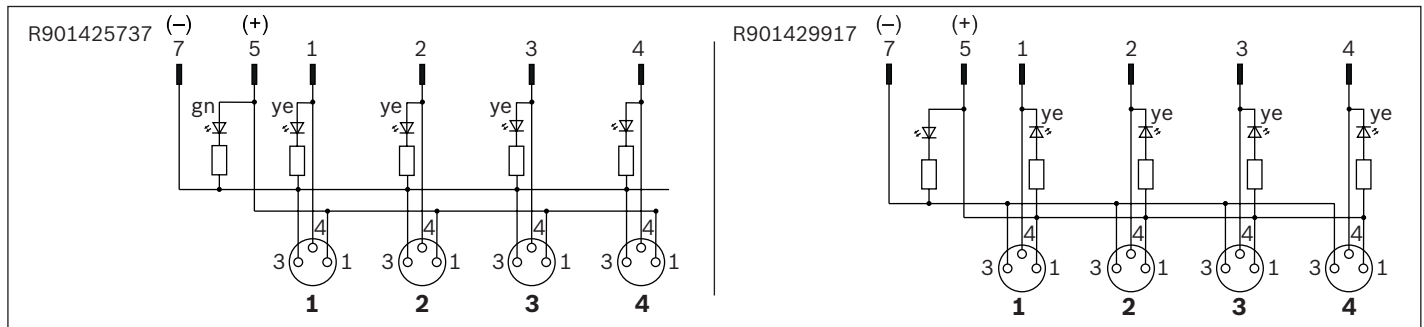
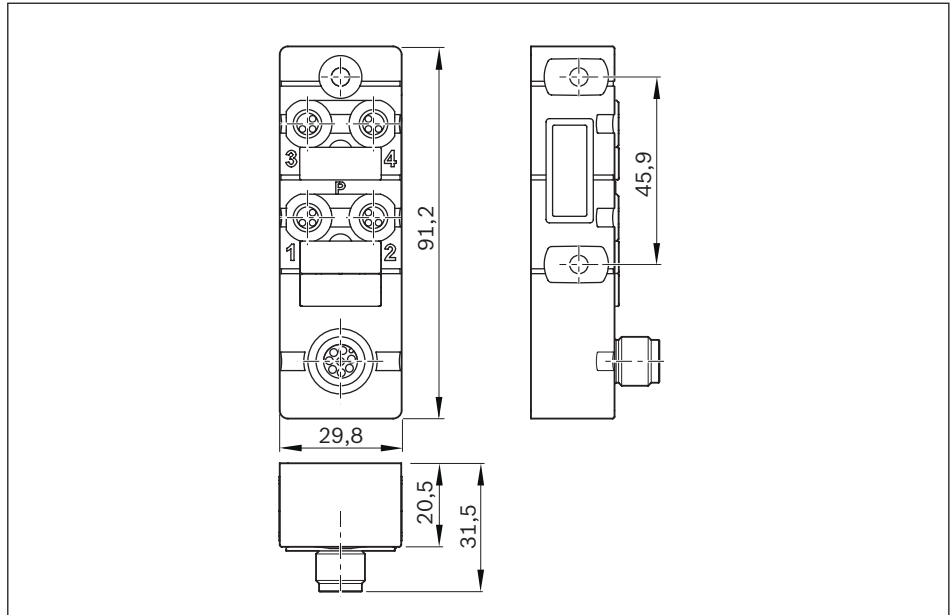
Passive distributor



Part numbers/technical data

Use	Passive distributor		
Part number	R901425737	R901429917	R911344592
Designation	8000-84070-0000000	8000-84071-0000000	
Version	straight, for 1 - 4 sensors		
Operating current per contact	max. 2 A		
Operating voltage	24 VDC		
Switching logic	PNP	NPN	
1st connection type	4x female connector, straight, M8x1, 3-pin, self-locking screw thread		
2nd connection type	Straight plug, M12x1, 8-pin, IDC, self-locking screw thread		
Function indicator	✓		
Operating voltage indicator	✓		
Connection cross-section	-		
Ambient temperature	-20 °C to +70 °C		
IP rating	IP67 (inserted and locked)		
Certifications and approvals	  		

Technical data and dimensional drawing see Adapters

Accessories for passive distributors

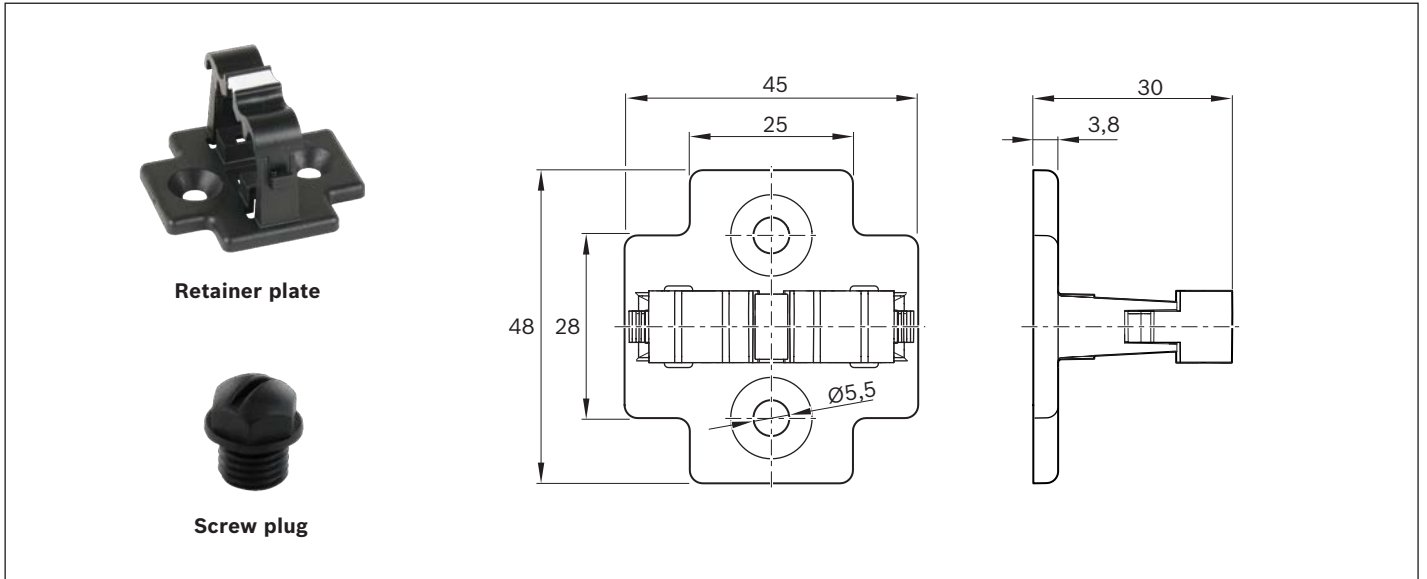

Part numbers/technical data



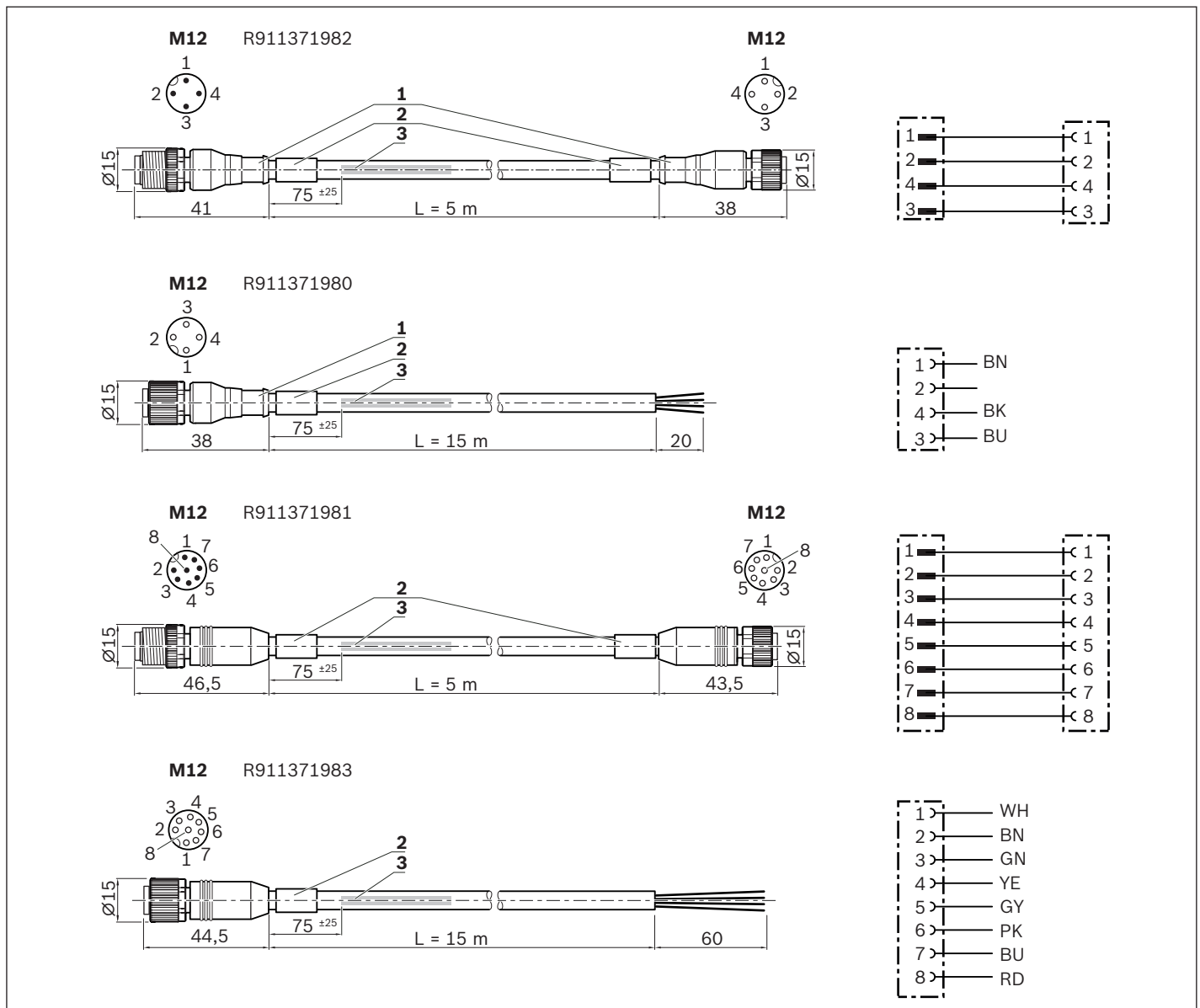
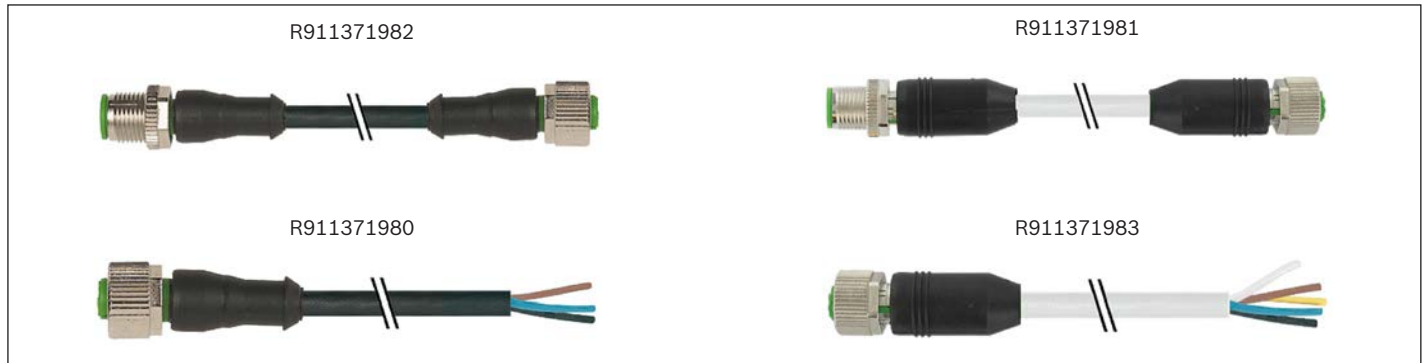

Use	For passive distributor R911344592	For passive distributors R901425737/R901429917
Retainer plate	R913047341	-
Designation	7000-99061-0000000	-
Set	1 unit	-
Screw plug	-	R913047322
Designation	-	3858627
Set	-	10 units

Extensions for passive distributors



1) Contour for conduit pipe with inner diameter of 10
2) Cable grommet
3) Cable print per ordering specification 7000-08001

Part numbers/technical data

Use	Extension cable for passive distributor R911344592		Extension cable for passive distributor R901425737 / R901429917	
Part number	R911371982	R911371980	R911371981	R911371983
Designation	7000-40021-6540500	7000-12221-6541500	7000-48001-3770500	7000-17041-3771500
Length	5.0 m	15.0 m	5.0 m	15.0 m
1st connection type	Female connector, straight, M12x1, 4-pin		Female connector, straight, M12x1, 8-pin	
2nd connection type	Straight plug, M12x1, 4-pin	Unassembled cable end	Straight plug, M12x1, 8-pin	Unassembled cable end
Function indicator	-			
Operating voltage indicator	-			
Type of cable	PUR black		PUR gray	
Operating voltage	30 V AC/DC			
Operating current per contact	max. 4 A per contact		max. 2 A per contact	
Suitable for drag chains	✓			
Torsion-resistant	✓			
Weld spark-resistant	✓			
Cable cross-section	4x0.34 mm ²		8x0.34 mm ²	
Cable diameter D	4.7 +/- 0.2 mm		6.2 +/- 0.3 mm	
Static bending radius	≥ 5 x D			
Dynamic bending radius	≥ 10 x D			
Bending cycles	> 10 mil.			
Max. permissible travel velocity	3.3 m/s for 5 m travel distance (typ.), up to 5 m/s for 0.9 m travel distance			
Max. permissible acceleration	≤ 30 m/s ²			
Ambient temperature fixed ext.	-40°C to +80°C (90° max. 10,000h)			
Ambient temperature flexible ext.	-25°C to +80°C (90° max. 10,000h)			
IP rating	IP67 (inserted and locked)			
Certifications and approvals	    			

Combination examples

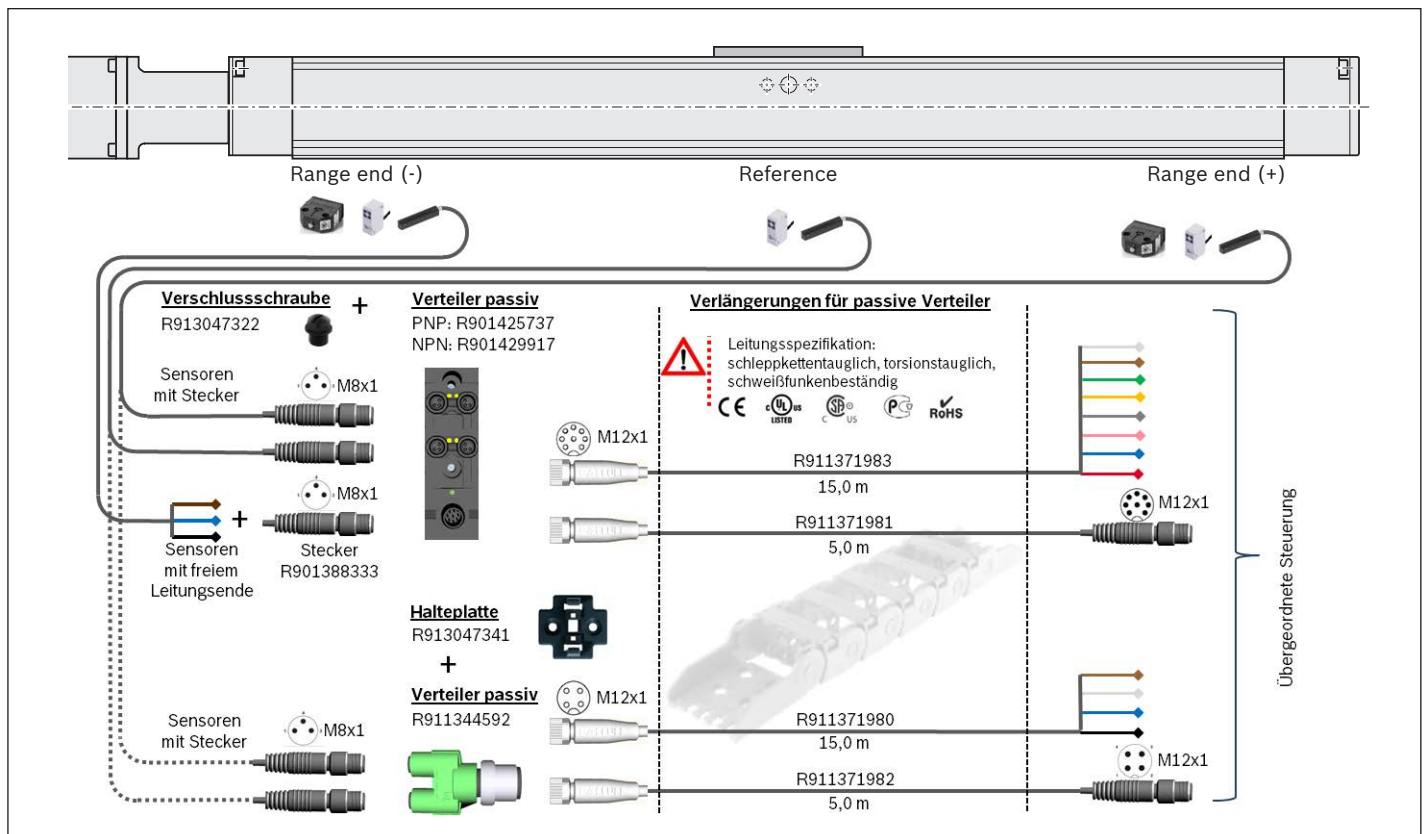
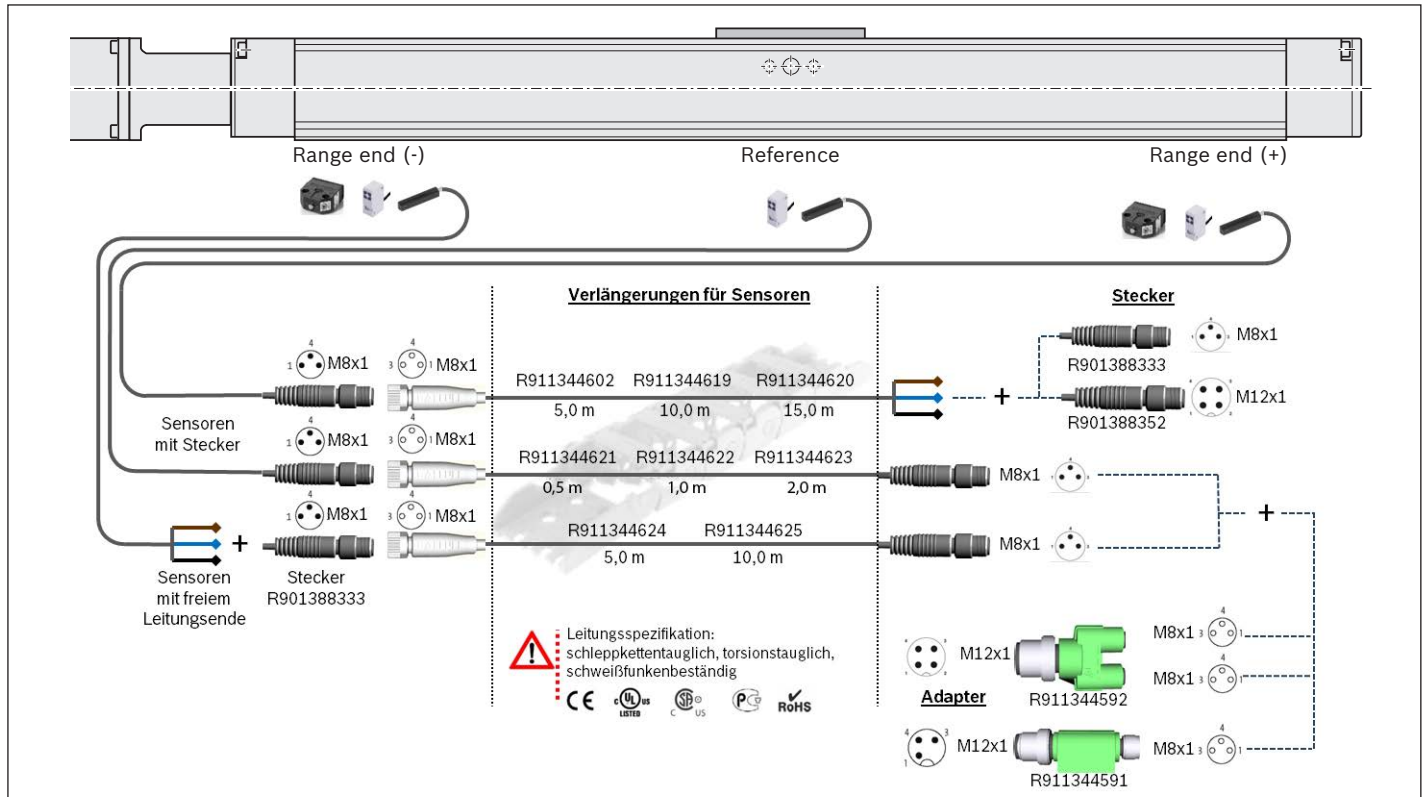

Socket and plug

Attach the socket on the side with the magnetic sensors. The socket and plug are not pre-wired. The variable sliding attachment allows switching positions to be optimized during start-up. The plug can be mounted in three directions.

R117560102

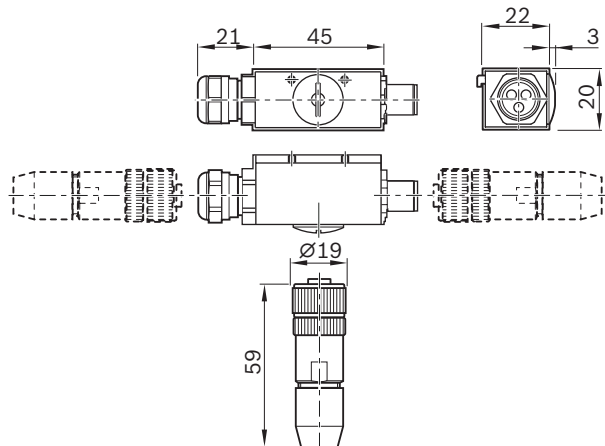
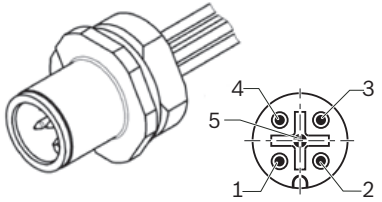

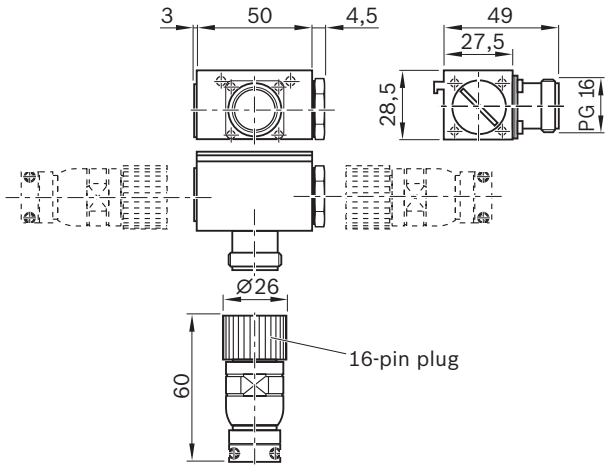
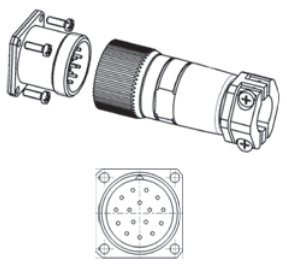

Pin		Color
1	BN	brown
2	WH	white
3	BU	blue
4	BK	Black
5	GY	gray

R037540000

R117500153

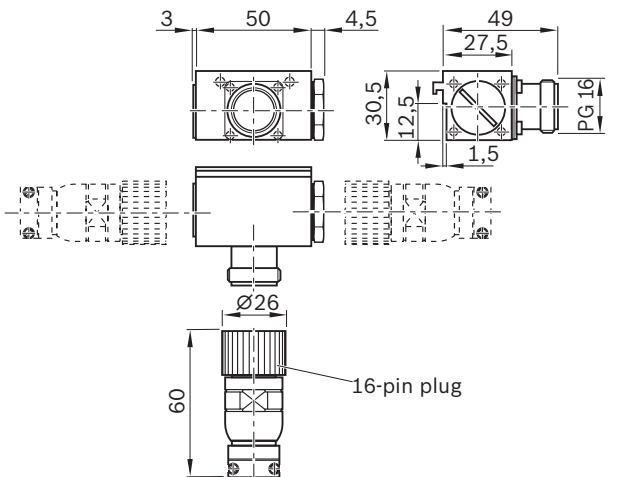
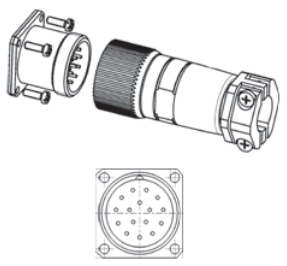
Use	Socket and plug	
Part number	R117560102	R037540000 / R117500153
Designation	for CKK / CKR-070	for CKK / CKR-090, -110, -145, -200
Version	angled, for suspension in the lateral slot of the linear motion system	
Operating current per contact	max. 4 A	max. 8 A
Operating voltage	10–30 V DC	150V AC/DC
1st connection type	Male connector, straight, M12x1, 5-pin, Spring-cage connection	Straight plug, 16-pin, Soldered connection
2nd connection type	Coupling / flange socket M12x1, 5-pin, with 0.5 m cable	Coupling / flange socket, 16-pin, Soldered connection
Housing cable bushing	Cable gland M16x1.5 with seal (hole 3x3.5 mm) incl. cap and dummy plug	1 seal with bore 2x5.5 mm, 1x3.5 mm 1 adaptable seal, max. 14 mm diameter incl. cap and dummy plug
Cable bushing, plug	Gland with pull relief	
Connection cross-section	0.14 ... 0.5 mm	0.14 ... 1 mm
Cable diameter	4 ... 8 mm	10 ... 14 mm
Ambient temperature	–25°C to +85°C	–20°C to +125°C
IP rating	–	
Certifications and approvals	–	

EasyHandling

The perfect system solution for every application

Efficient production processes are the key to your success in the marketplace. Today's environment, defined by rapid change and short product cycles, demands flexible systems with an optimal design and configuration. EasyHandling gives you the tools you need to automate your handling tasks with greater ease, speed, and efficiency. EasyHandling is more than just a modular collection of mechanical components; it takes an evolutionary step forward by providing an all-inclusive system solution – our best solution for your requirements.



EasyHandling – Easier. Faster. More economical.

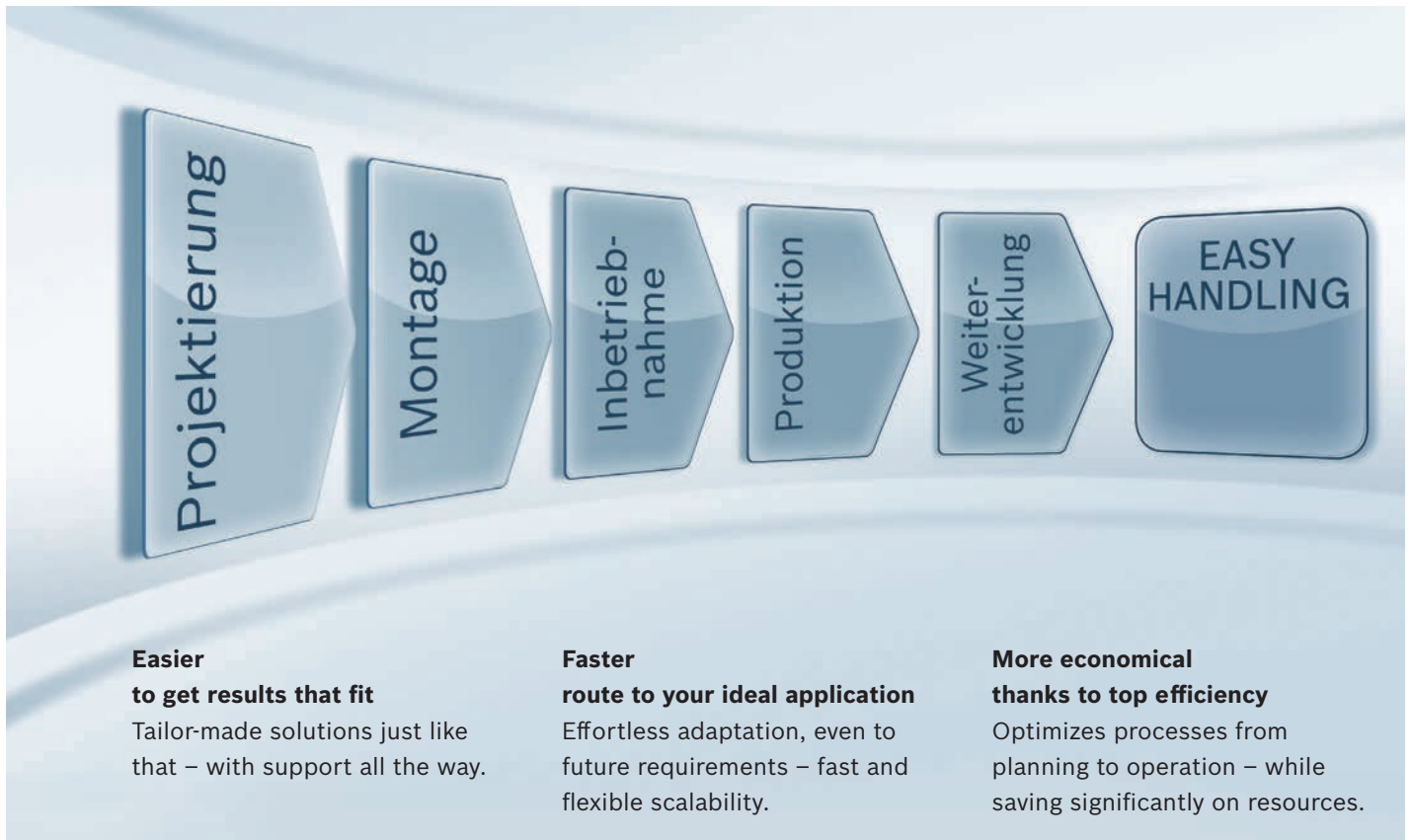

Planning – up to 70% faster

EasyHandling tools help users right from the component selection stage – by proposing solutions with all the necessary information on parts lists, technical data and CAD drawings.

Mounting – saves up to 60% on time

Thanks to positive-locking interfaces, the mechanical components are perfectly aligned and accurately connected right away.

Start-up – reduces your effort by up to 90%

With the smart start-up assistant EasyWizard, parameterization and configuration take no time at all. Your handling system will be ready to go in just a few clicks.

Production – more economical and more efficient

Rexroth enhances the system effectiveness still further with smart application tools: The drive controller software sends maintenance-related messages to the user based on operating hours and travel to help schedule servicing at the right intervals. The result: longer life and reduced risk of failure.

Future developments – continuous improvement

Prepare now for future market developments: One of the great features of EasyHandling systems is their openness. The flexibility of the mechanical and electrical components allows you to adapt quickly and efficiently to new production requirements.

EasyHandling – more than just a building system

The modular system concept
for perfect scalability

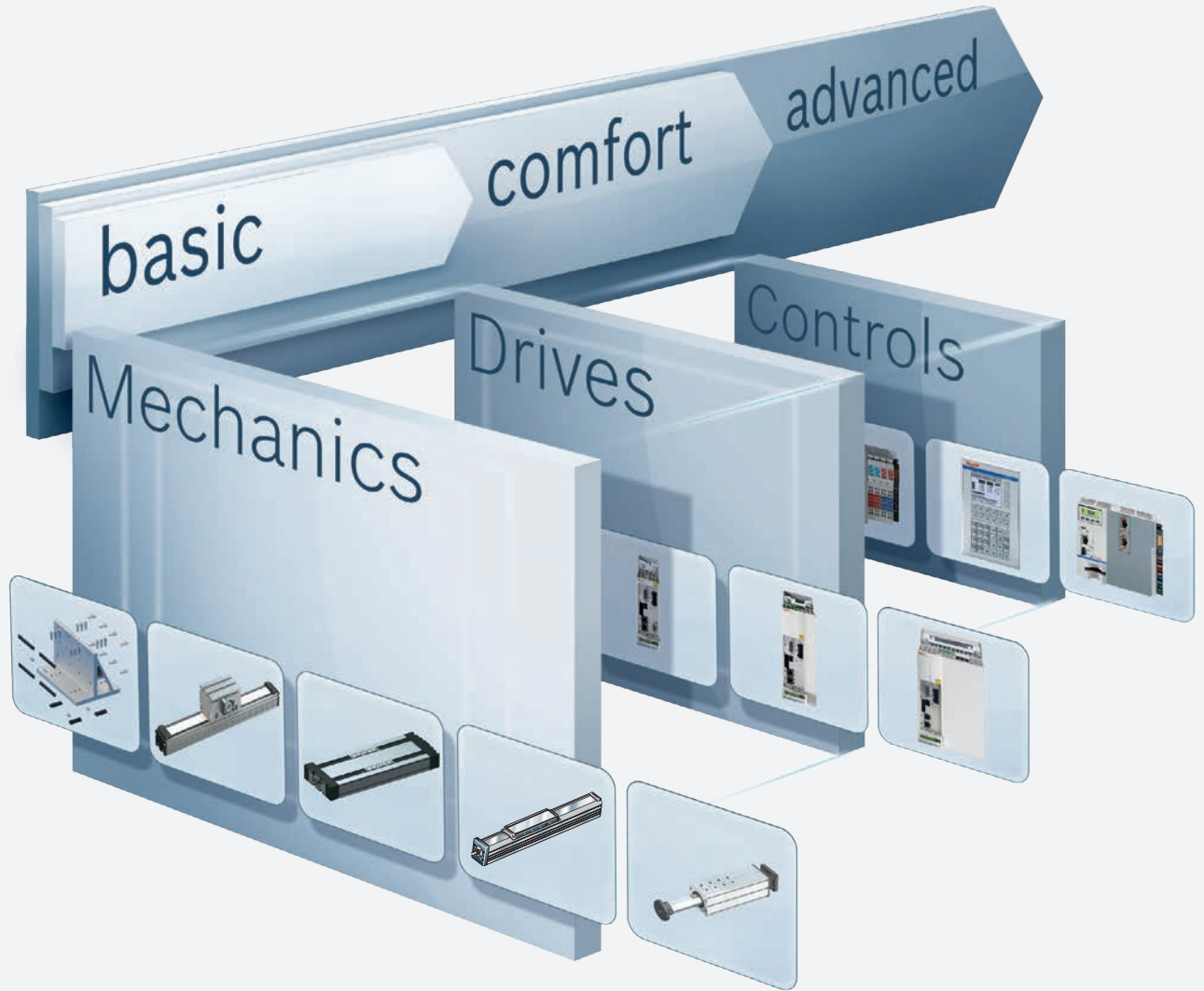

basic – made-to-measure mechanics

EasyHandling basic includes all mechatronic components for complete, custom **single and multi-axis systems**.

All of the component interfaces are systematically standardized, making it possible to combine them with ease. Practical tools and aids make selection and configuration even easier.



comfort – get off to a faster start

EasyHandling comfort expands the basic component range by adding **powerful servo drives with multiple-protocol capability**. The universal, smart control units are ideally suited for a variety of handling tasks. It also features the unique **EasyWizard start-up assistant**. Generate ready-to-use linear motion systems in a snap by entering just a few application-specific parameters.



advanced – controls for demanding requirements

With its **individually scalable, high-performance Motion Logic solution**, EasyHandling advanced makes configuration and handling even easier. Predefined functions covering more than 90% of all handling applications eliminate the need for lengthy programming.



For more information about EasyHandling, see the brochure "EasyHandling – more than just a building system" R999000044.



Service and information

Operating conditions

Normal operating conditions

Ambient temperature with Bosch Rexroth servo motor	0 °C ... 40 °C, above 40 °C loss of performance
Ambient temperature for mechanical system (no dropping below dew point)	-10 °C ... 60 °C
Travel $s_{\min}^{1)}$	see the CKK/CKR "technical data" table
Soiling	Do not allow

¹⁾ Minimum travel to ensure a reliable lubrication distribution.

Required and supplementary documentation

For further instructions and information, please refer to the documentation for this product.

You can find PDF files of these documents on the Internet at www.boschrexroth.com/mediadirectory.

We would also be happy to send you the documents that you want.

If you are unsure about using this product, please contact Bosch Rexroth.

Lubrication

CKK Compact Modules

Lube port in frame for lube versions LSS/LPG

On each side of the frame of the CKK Compact Modules there are holes through which the lube nipples in the carriage can be accessed. Lubrication from one side only is sufficient.

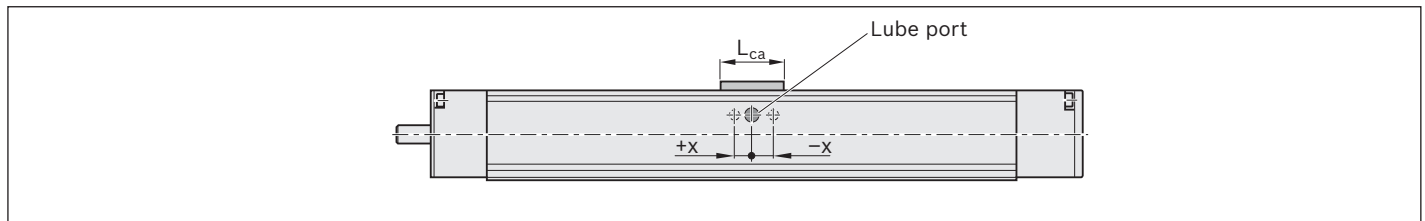
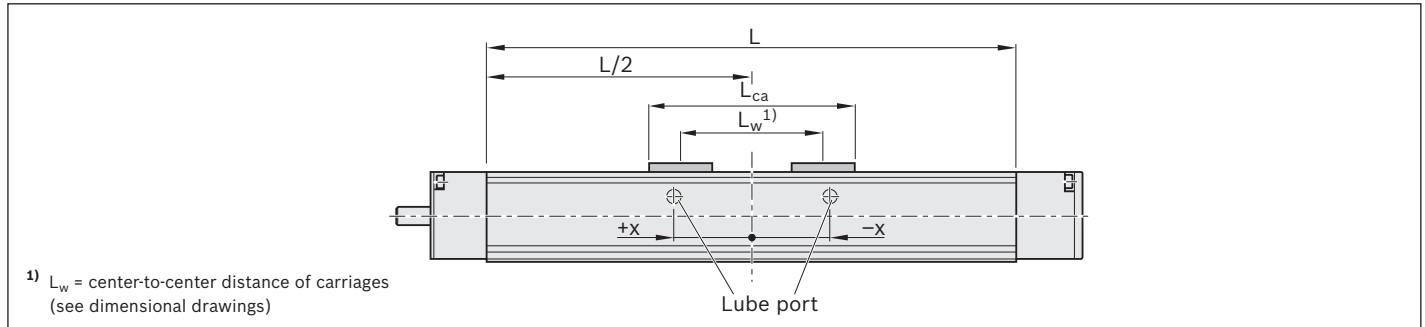

CKK	Carriage length		Lube port	Distance	Lube nipple
	L_{ca} (mm)	Quantity			
-070	32	1		-12.5	DIN 3405-D 3
	73	1		0.0	
	60	1		-12.5	
	95	1		0.0	
-090	35	1		0.0	DIN 3405-D 3
	100	2		± 32.5	
	variable	2		$\pm L_w/2$	
	60	1		0.0	
-110	125	2		± 32.5	DIN 3405-D 3
	39	1		6.5	
	124	2		± 49.5	
	variable	2		$\pm (L_w/2 + 6.5)$	
	60	1		6.5	
-145	155	2		± 49.5	DIN 3405-D 3
	49	1		7.0	
	149	2		± 57.0	
	variable	2		$\pm (L_w/2 + 7.0)$	
	80	1		7.0	
-200	190	2		± 57.0	DIN 3405-A M8x1
	79.5	1		-15.0	
	254.5	2		± 102.5	
	variable	2		$\pm (L_w/2 + 15.0)$	
	190	1		-15.0	
	305	2		± 102.5	

Lube fittings for carriage attachments for lube versions LSS/LPG

The lube fittings are sealed with (a) set screw(s) in the factory before shipment. To use the lube fittings, remove the set screw(s) for **S₁** or **S₂**. See drawing and table for connection dimensions and O-rings.

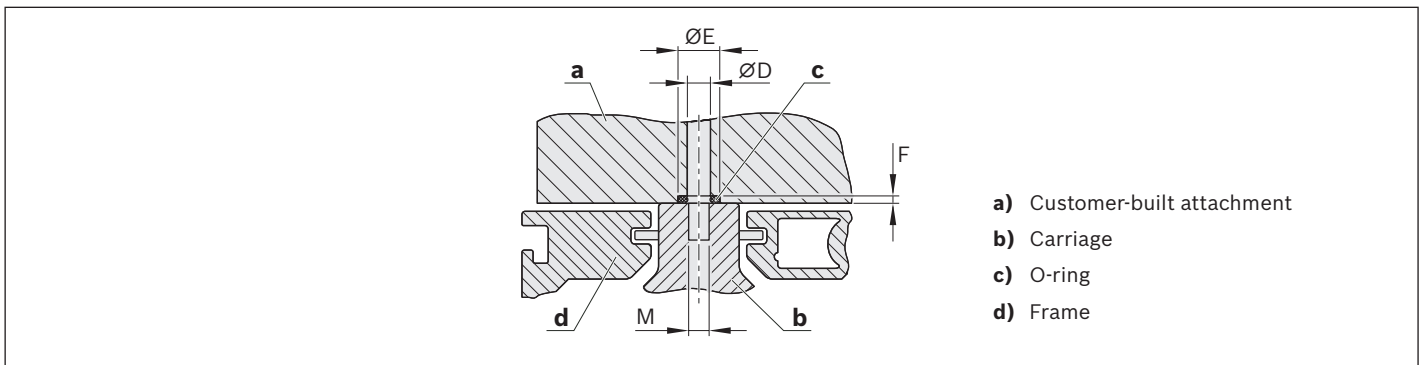
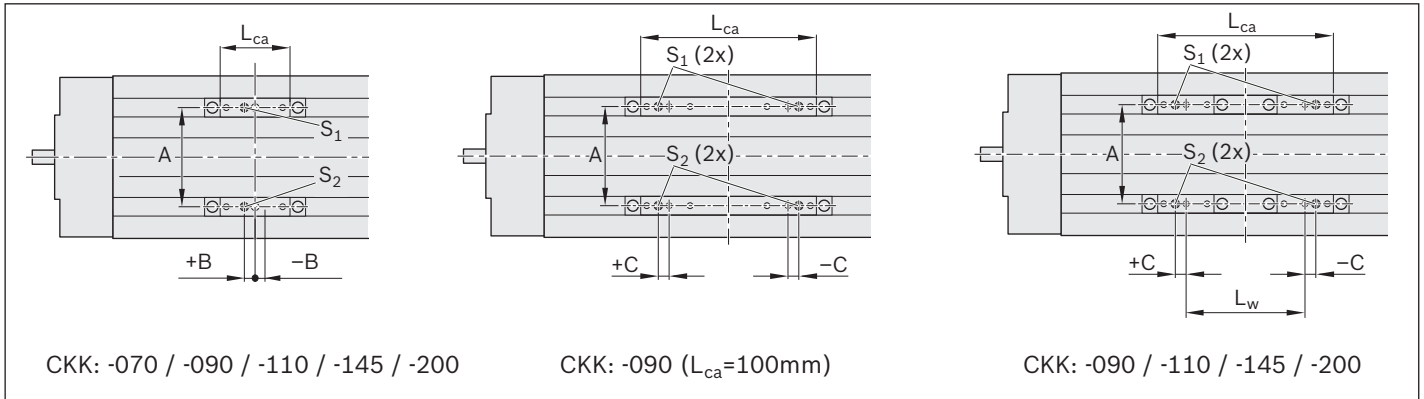

CKK	Carriage length L _{ca} (mm)	Center-to-center distance of carriages L _w (mm)	Dimensions (mm)							O-Ring acc. to DIN3771	
			A	B	C	Ø D ±0.2	Ø E ±0.2	F +0.2	M	Size	Part number
-070	32.0	-	40	-5.0	-	2.5	5.0	0.6	M3	3 x 1.0	R341111801
	73.0	-		0.0	-						
-090	35.0	-	54	6.0	-	3.0	6.2	1.0	M3	3 x 1.5	R341100101
	100.0	-		-	6.0						
	variable	variable		-	6.0						
-110	39.0	-	66	6.5	-	3.0	6.2	1.0	M3	3 x 1.5	R341100101
	124.0	85		-	6.5						
	variable	variable		-	6.5						
-145	49.0	-	88	7.0	-	3.0	6.2	1.0	M3	3 x 1.5	R341100101
	149.0	100		-	7.0						
	variable	variable		-	7.0						
-200	79.5	-	130	-15.0	-	5.0	9.0	1.0	M4	5 x 1.5	R341110801
	254.5	175		-	15.0						
	variable	variable		-	15.0						

Lube fittings for carriages with connection plate

Dimensioning ➡ "Connection plates" chapter

CKR Compact Modules

Lube port in frame for lube versions LSS/LPG

On each side of the frame of the CKR Compact Modules, there are holes through which the lube nipples in the carriage can be accessed. Lubrication from one side only is sufficient.

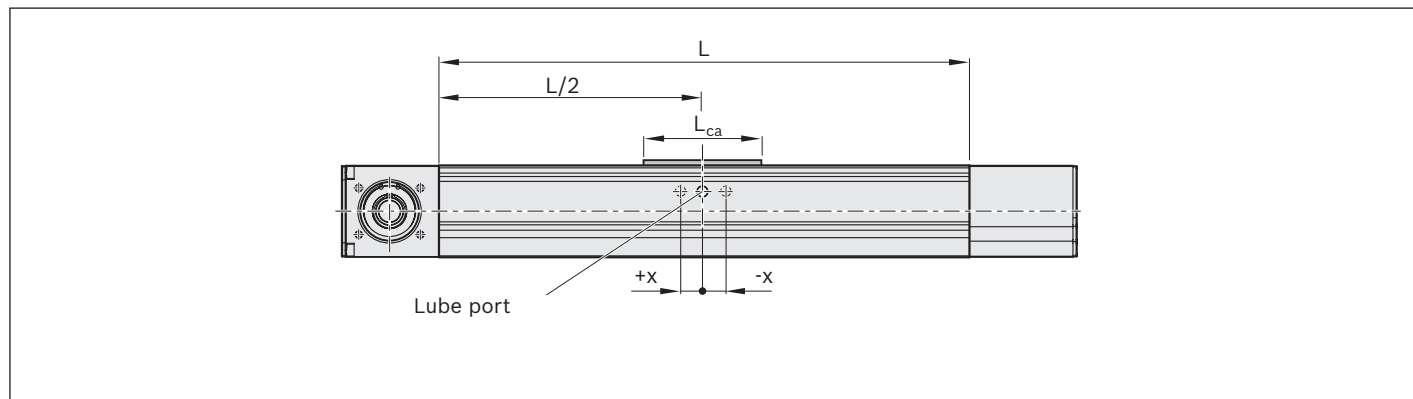

Depending on the carriage length, move to the lubrication position in accordance with the table (distance x).

CKR	Carriage length		Distance	Lube nipple
		L _{ca} (mm)		
-070		80	0.0	DIN 3405-D 4
		108	5.0	
		60	0.0	
		95	5.0	
-090		102	0.0	DIN 3405-D 4
		108		
		60		
		125		
-110		170	-41.5	DIN 3405-A M6
		215	0.0	
		110	-41.5	
		155	0.0	
-145		180	-50.0	DIN 3405-A M6
		240	0.0	
		125	-50.0	
		190	0.0	
-200		265	-59.0	DIN 3405-A M8x1
		465	0.0	
		190	-59.0	
		305	0.0	

Lube fittings for carriage attachments for lube versions LSS/LPG

The lube fittings are sealed with a set screw in the factory before shipment. To use the lube connection, the set screw S_1 has to be removed.

See the table for connection dimensions and O-rings.

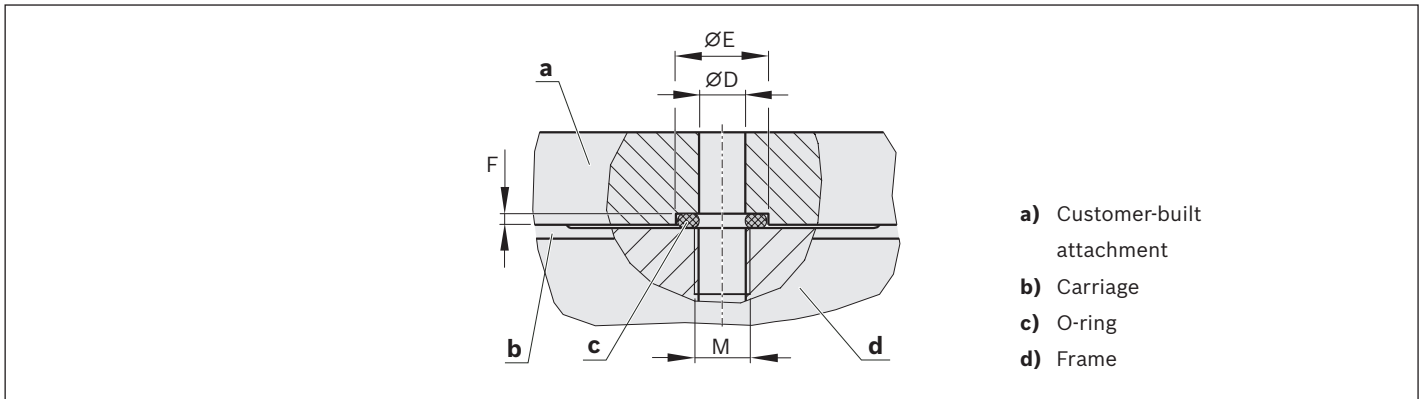
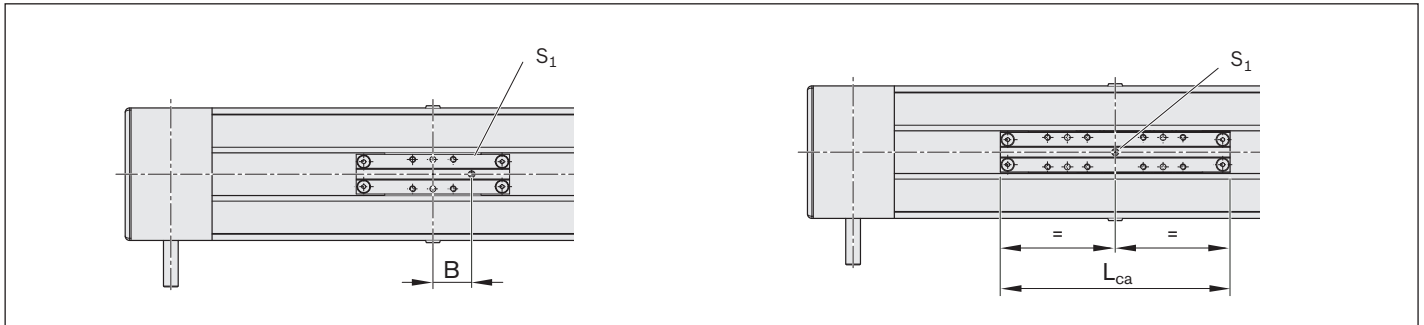

CKR	Carriage option	Carriage length L_{ca} (mm)	Dimensions					O-Ring acc. to DIN3771	
			B	$\varnothing D$ ± 0.2	$\varnothing E$ ± 0.2	F $+0.2$	M	Size	Part number
-070	01	80	0.0	2.5	6.0	0.6	M3	3 x 1.5	R341100101
	02	108							
-090	01	102	0.0	3.0	10.0	1.7	M4	4 x 2.5	R341111901
	02	156							
-110	01	170	41.5	5.0	10.0	1.2	M6	5 x 2	R341110901
	02	215	0.0						
-145	01	180	50.0	5.0	10.0	1.2	M6	5 x 2	R341110901
	02	240	0.0						
-200	01	265	59.0	6.0	12.2	1.0	M8	8 x 2	R341100801
	02	465	0.0						

Lube fittings for carriages with connection plate

Dimensioning \Rightarrow "Connection plates" chapter

Lubricants

Lubrication type	LSS		LPG	
Size	CKx-110, -145, -200	CKx-070, -090	CKx-110, -145, -200	CKx-070, -090
Basic lubrication	Dynalub 510	Dynalub 520	Preserved, basic lubrication required (see instructions)	
Consistency class	NLGI 2 (DIN 51818)	NLGI 00 (DIN 51818)	-	
Identification	KP2K-20 (DIN 51825)	GP00K-20 (DIN 51826)	-	
Lubrication with grease gun	yes	yes	yes	
Prepared for connection to central lubrication systems	-	-	-	
Recommended lubricants	Dynalub 510 (grease lubricant) (NLGI 2 DIN 51818)	Dynalub 520 (liquid grease) (NLGI 00 DIN 51818)	Dynalub 510 (grease lubricant) (NLGI 2 DIN 51818)	Dynalub 520 (liquid grease) (NLGI 00 DIN 51818)
Features	<ul style="list-style-type: none"> • Good water resistance • Corrosion protection • Temperature range: -20 to +80 °C 		<ul style="list-style-type: none"> • Good water resistance • Corrosion protection • Temperature range: -20 to +80 °C 	
Part numbers	R3416 037 00 (400 g cartridge)	R3416 043 00 (400 g cartridge)	R3416 037 00 (400 g cartridge)	R3416 043 00 (400 g cartridge)
	R3416 035 00 (25 kg container)	R3416 042 00 (5 kg bucket)	R3416 035 00 (25 kg container)	R3416 042 00 (5 kg bucket)
Alternative lubricants	<ul style="list-style-type: none"> • Tribol GR 100-2 PD • Elkalub GLS 135/N2 	<ul style="list-style-type: none"> • Tribol GR 100-00 PD • Elkalub GLS 135/N00 	<ul style="list-style-type: none"> • Tribol GR 100-2 PD • Elkalub GLS 135/N2 • Tribol GR 100-00 PD • Elkalub GLS 135/N00 • Dynalub 520 	<ul style="list-style-type: none"> • Tribol GR 100-00 PD • Elkalub GLS 135/N00
Alternative lubricants with H1 approval	-	-	<ul style="list-style-type: none"> • Berulub FG H2 SL • Cassida Grease EPS2 • VP 874 	<ul style="list-style-type: none"> • Berulub FB 34-00 • Elkalub GLS 367/N00

Notes on lubrication

- ▶ Follow the product instructions.
- ▶ Do not use lubricants with solid particles (e.g. graphite or MoS₂).
- ▶ If using different lubricants than the ones specified, relubrication intervals may be shorter and performance may decrease with short stroke and load ratio; in addition, chemical interactions can take place between the plastics, lubricants and preservative agents. Single-line central lubrication systems also need to be able to pump these lubricants.
- ▶ If using a central lubrication system, make sure all lines and elements are filled with lubricant all the way to the connection to the consumer (carriage) and that there are no air bubbles.
- ▶ Lubricant reservoirs should contain an agitator to ensure the lubricant can flow (avoids hardening in the reservoir).
- ▶ For relubrication, it is not possible to switch from grease to oil lubrication and vice-versa.
- ▶ If environmental factors such as contamination, vibrations, impact loads, etc. are present, we recommend shorter lubrication intervals. Even under normal operating conditions, relubrication is required every two years due to grease aging.
- ▶ Rexroth recommends piston distributors by SKF. These should be installed as close to the carriage lube fittings as possible. Avoid long lines (no longer than 1 m) and narrow line diameters. Install the lines at a gradient.
- ▶ If other consumers are connected to the single-line lubrication system, the weakest link in this chain determines the lubrication cycle.
- ▶ Excess lubricant can accumulate inside of the Compact Modules or flow out and may lead to contamination of the environment
- ▶ Never put a Compact Modules into operation without basic lubrication.

	LCF	LCO
	CKx-090, -110, -145, -200	CKx-090, -110, -145, -200
	required, see instructions	required, see instructions
	NLGI 00 (DIN 51818)	-
	GP00K-20 (DIN 51826)	-
	-	-
	<ul style="list-style-type: none"> • only via single-line piston distributor system • smallest permitted piston distributor size: CKx-090, -110, -145, -200: 0.2 cm³ 	<ul style="list-style-type: none"> • only via single-line piston distributor system • smallest permitted piston distributor size: CKx-090, -110: 0.2 cm³; CKx-145: 0.4 cm³; CKx-200: 0.6 cm³
	Dynalub 520 (liquid grease) (NLGI 00 DIN 51818)	Shell Tonna S3 M220 (lubricant oil)
	<ul style="list-style-type: none"> • Good water resistance • Corrosion protection • Temperature range: -20 to +80 °C 	<ul style="list-style-type: none"> • Special demulsifying oil CLP or CGLP as per DIN 51517-3 for machine bed tracks and tool guides • A blend of highly refined mineral base oils and additives • Can be used even when mixed with significant quantities of metalworking fluids
	R3416 043 00 (400 g cartridge)	-
	R3416 042 00 (5 kg bucket)	-
	<ul style="list-style-type: none"> • Tribol GR 100-00 PD • Elkalub GLS 135/N00 	<ul style="list-style-type: none"> • Special demulsifying oil CLP or CGLP as per DIN 51517-3 for machine bed tracks and tool guides
	-	-

Use of lubricants with H1 approval:

Loss of H1 approval

H1 lubricants or release agents (preservative agents) only have H1 approval if they are separated and unmixed (including at the lubrication point). A blend of two H1 approval lubricants or separating agents does not have H1 approval.

No approval or authorization for use in the food industry

Because of the use of H1 lubricants, the Compact Modules do not have authorization or approval for the food industry.

Components lubricated at the factory

Components lubricated by the manufacturer at the factory such as deep-groove ball bearings, cover strips, gears, etc. do not use H1 lubricants.

Compact Modules with Dynalub 520 (NLGI 00 class) initial greasing must not be pre-lubricated with lubricants of consistency class NLGI 2!

For relubrication quantity and relubrication position ⇒ see Compact Modules CKK/Compact Modules CKR instructions.

Relubrication interval

When using the standard lubrication from the manufacturer:

Relubrication interval ⇒ see Compact Modules CKK/Compact Modules CKR instructions.

Use of Dynalub 520 (NLGI 00) instead of Dynalub 510 (NLGI 2):

The relubrication interval is 75% of the standard relubrication interval ⇒ CKK/CKR instructions.

Use of lubricants with H1 approval:

First relubrication takes place after 20 km. As a guideline value for relubrication intervals, 50% of the standard relubrication intervals must be applied ⇒ see Compact Modules CKK/Compact Modules CKR instructions.

Parameterization (start-up)

The nameplate contains reference information on the production of the linear motion system as well as technical start-up parameters.

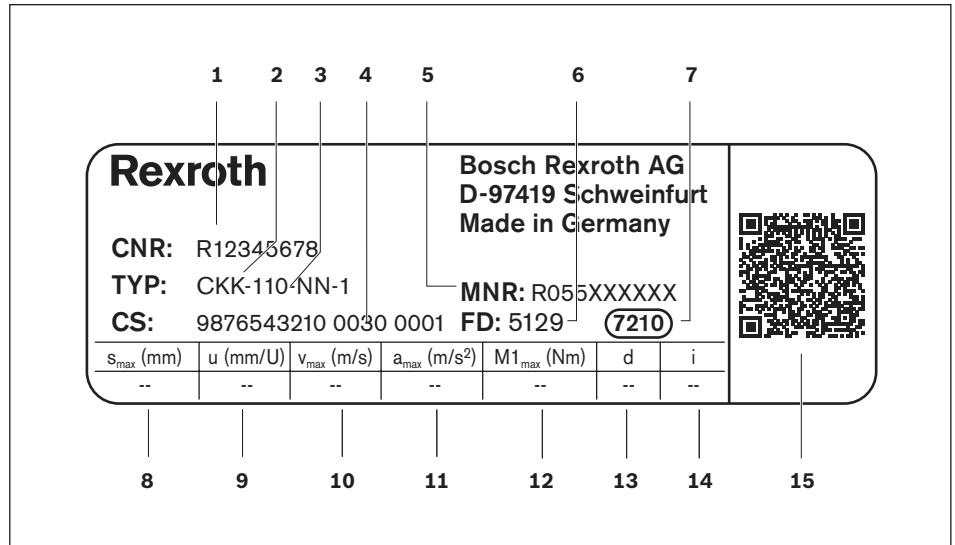

1	CNR	Customer's part number
2	TYP	Short product name
3	110	Size
4	CS	Customer information
5	MNR	Part number
6	FD	Date of manufacture
7	7210	Manufacturing location
8	s_{max}	Maximum travel range
9	u	Feed constant without motor attachment
10	v_{max}	Maximum speed
11	a_{max}	Maximum acceleration
12	$M1_{max}$	Maximum drive torque at motor journal
13	d	Direction of motor rotation to move in positive (+) direction CW = clockwise CCW = counterclockwise

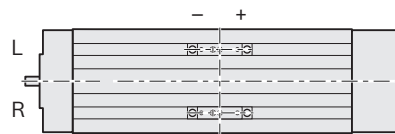
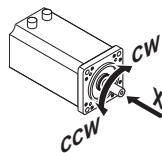

14	i	Gear ratio
15		QR code

Documentation

Standard report

Option 01

The standard report serves to confirm that the checks listed in the report have been carried out and that the measured values lie within the permissible tolerances.

Checks listed in the standard report:

- ▶ Functional checks of mechanical components
- ▶ Functional checks of electrical components
- ▶ Design is in accordance with order confirmation

Measurement of frictional torque of complete system

Option 02 (includes option 01)

The moment of friction is measured over the entire travel range.

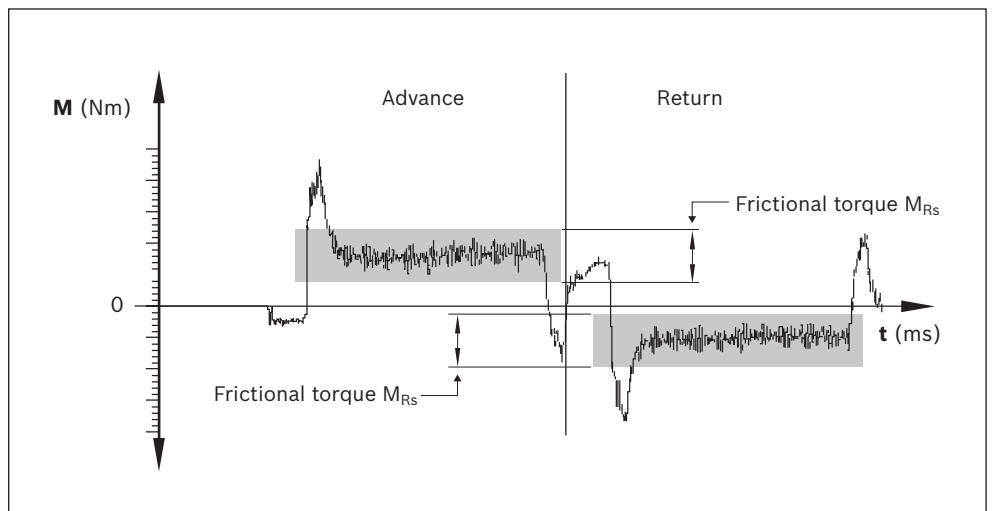

Lead deviation of Ball Screw Assembly for CKK Compact Modules

Option 03 (includes option 01)

In addition to graphical representation (see illustration), a measurement report is supplied in table form.

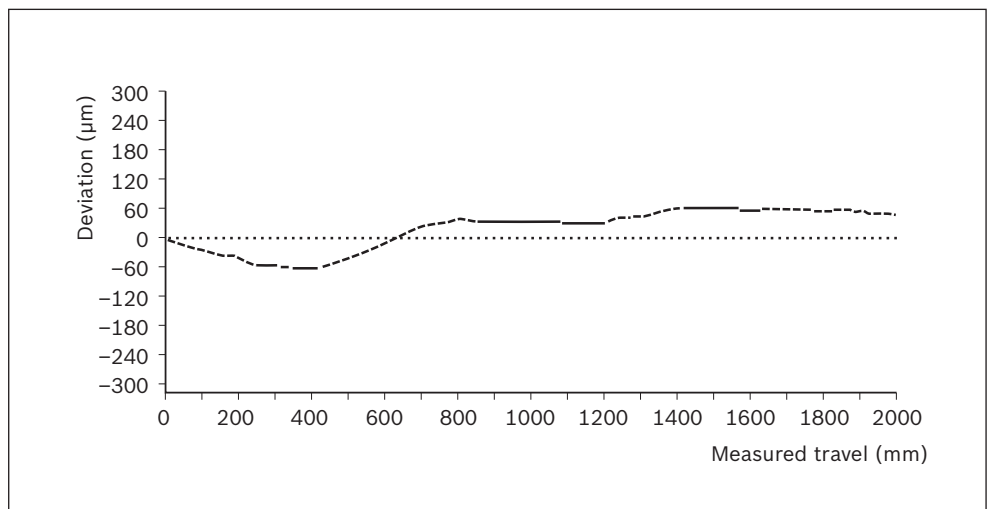

Project planning/calculation

Calculation principles

Calculation principles	138
Length calculation	138
Note on dynamic load capacities and moments	139
Maximum permissible load	140
Life expectancy calculation of the linear guide	140
Service life of Ball Screw Assembly or the fixed bearing	141
Drive dimensioning	142
Basic principles	143
Drive dimensioning with motor shaft as reference point	144
General motor preselection	146
Sample calculations	148
Sample calculation CKK	148
Sample calculation CKR	152
For the abbreviations refer to the "Abbreviations" chapter	156

Length calculation of the linear motion system

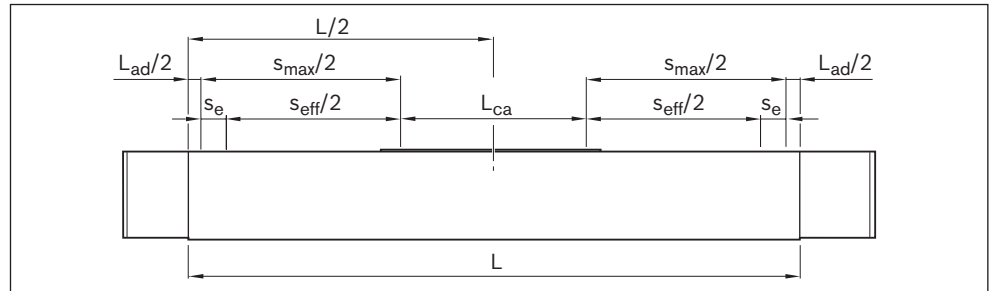

For length calculation values, see the section titled "Technical data" for the desired Compact Modules (CKK/CKR)

$$L = s_{\text{eff}} + 2 \cdot s_e + L_{\text{ca}} + L_{\text{ad}}$$

Effective stroke

$$s_{\text{eff}} = s_{\text{max}} - 2 \cdot s_e$$

Stroke: maximum distance from carriage center to the outer-most switch activation points.

Excess travel: Excess travel must be greater than braking distance. The acceleration travel can be adopted as the guideline value for the braking distance.

Mass of the linear motion system

Weight calculation:

- ▶ without motor
- ▶ without switch mounting
- ▶ without motor attachment

$$m_s = k_g \text{ fix} + k_g \text{ var} \cdot L + m_{\text{ca}}$$

Note on dynamic load capacities and moments

Determination of the dynamic load capacities and moments is based on a total travel of 100,000 m. Often only 50,000 m of total travel are actually stipulated. For comparison: Multiply values C , M_t and M_L by a factor of 1.26.

Suitable loads

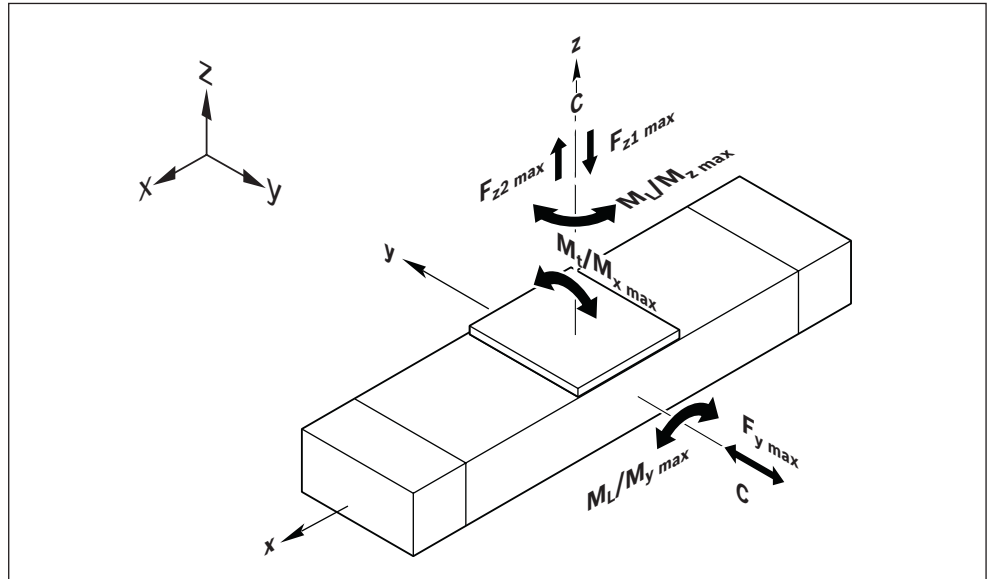

With respect to the desired nominal life, loads for F_{mgw} , F_{mbs} up to approx. 20% of the dynamic characteristics (C_{gw} , C_{bs}) have generally proven suitable. See "Planning" chapter. Do not exceed the technical data for the linear motion system.

Application point of the effective force (Z_1)

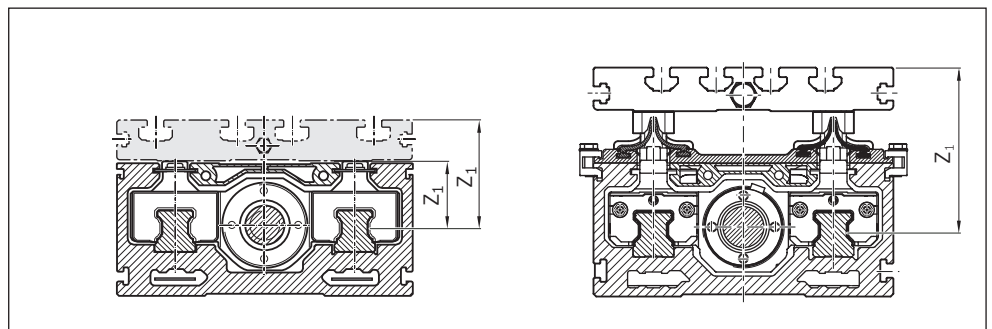

Modulus of elasticity E

$E = 70\,000 \text{ N/mm}^2$

Maximum permissible load

When selecting Linear Motion Systems, it is essential to consider the maximum permissible load and force tolerances. The values depend on the system. In other words, the tolerances are determined not only by the load ratings of the bearing points but also tolerances based on design and material.

Conditions for combined loads:

$$\frac{|F_y|}{F_{y \max}} + \frac{|F_z|}{F_{z \max}} + \frac{|M_x|}{M_{x \max}} + \frac{|M_y|}{M_{y \max}} + \frac{|M_z|}{M_{z \max}} \leq 1$$

Life expectancy calculation of the linear guide

Where the operating conditions vary (speed and load), the service life must be calculated using the average values v_{mrs} and F_{mrs} .

Nominal life in meters:

$$L_{gw} = \left(\frac{C_{gw}}{F_{mgw}} \right)^3 \cdot 10^5$$

Nominal life in hours:

$$L_{hgw} = \frac{L_{gw}}{3600 \cdot v_{mgw}}$$

Dynamic equivalent load on bearing of the guideway:

$$F_{mgw} = \sqrt[3]{|F_{eff1}|^3 \cdot \frac{q_{t1}}{100\%} + |F_{eff2}|^3 \cdot \frac{q_{t2}}{100\%} + |F_{eff3}|^3 \cdot \frac{q_{t3}}{100\%} + |F_{effn}|^3 \cdot \frac{q_{tn}}{100\%}}$$

The following applies to linear motion systems:

$$F_{eff} = F_{comb}$$

Combined equivalent bearing load:

$$F_{comb} = |F_y| + |F_z| + C_{gw} \cdot \frac{|M_x|}{M_t} + C_{gw} \cdot \frac{|M_y|}{M_L} + C_{gw} \cdot \frac{|M_z|}{M_L}$$

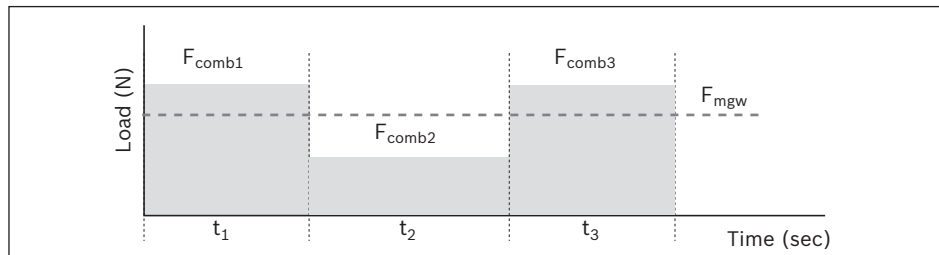

Mean speed of the guideway:

$$v_{mgw} = \frac{|v_1| \cdot q_{t1} + |v_2| \cdot q_{t2} + \dots + |v_n| \cdot q_{tn}}{100\%}$$

Service life of Ball Screw Assembly or the fixed bearing

Under variable operating conditions (rotary speed and load), the means F_{mbs} and n_m have to be used when calculating life.

Nominal life in revolutions:

$$L_{bs} = \left(\frac{C_{bs}}{F_{mbs}} \right)^3 \cdot 10^6$$

Nominal life in hours:

$$L_{hbs} = \frac{L_{bs}}{60 \cdot n_m}$$

Dynamic equivalent load on bearing of the Ball Screw Assembly:

$$F_{mbs} = \sqrt[3]{|F_{eff1}|^3 \cdot \frac{|n_1|}{n_m} \cdot \frac{q_{t1}}{100\%} + |F_{eff2}|^3 \cdot \frac{|n_2|}{n_m} \cdot \frac{q_{t2}}{100\%} + |F_{eff3}|^3 \cdot \frac{|n_3|}{n_m} \cdot \frac{q_{t3}}{100\%} + \dots + |F_{effn}|^3 \cdot \frac{|n_n|}{n_m} \cdot \frac{q_{tn}}{100\%}}$$

The following applies to the axial load F_n for linear motion systems:

$$F_{eff} = |F_n|$$

When both the load and the rotary speed vary, the average load F_{mbs} is calculated as follows:

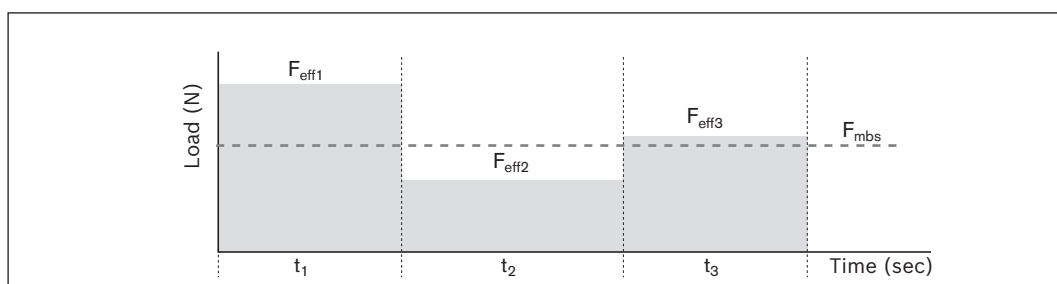

Mean speed of the spindle:

$$n_m = \frac{|n_1| \cdot q_{t1} + |n_2| \cdot q_{t2} + \dots + |n_n| \cdot q_{tn}}{100\%} = \frac{v_{mgw} \cdot 60\,000}{P}$$

If rotary speed varies, average rotary speed n_m is calculated as follows:

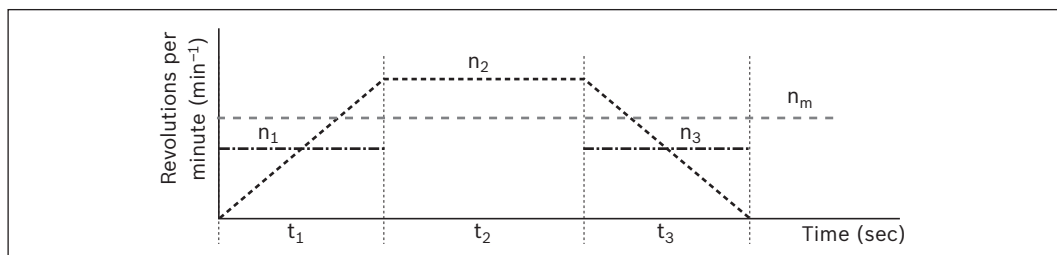

Rotary speed in acceleration and braking phases $n_1 \dots n$:

$$n_{1 \dots n} = \frac{n_{A1 \dots n} + n_{E1 \dots n}}{2}$$

Drive dimensioning

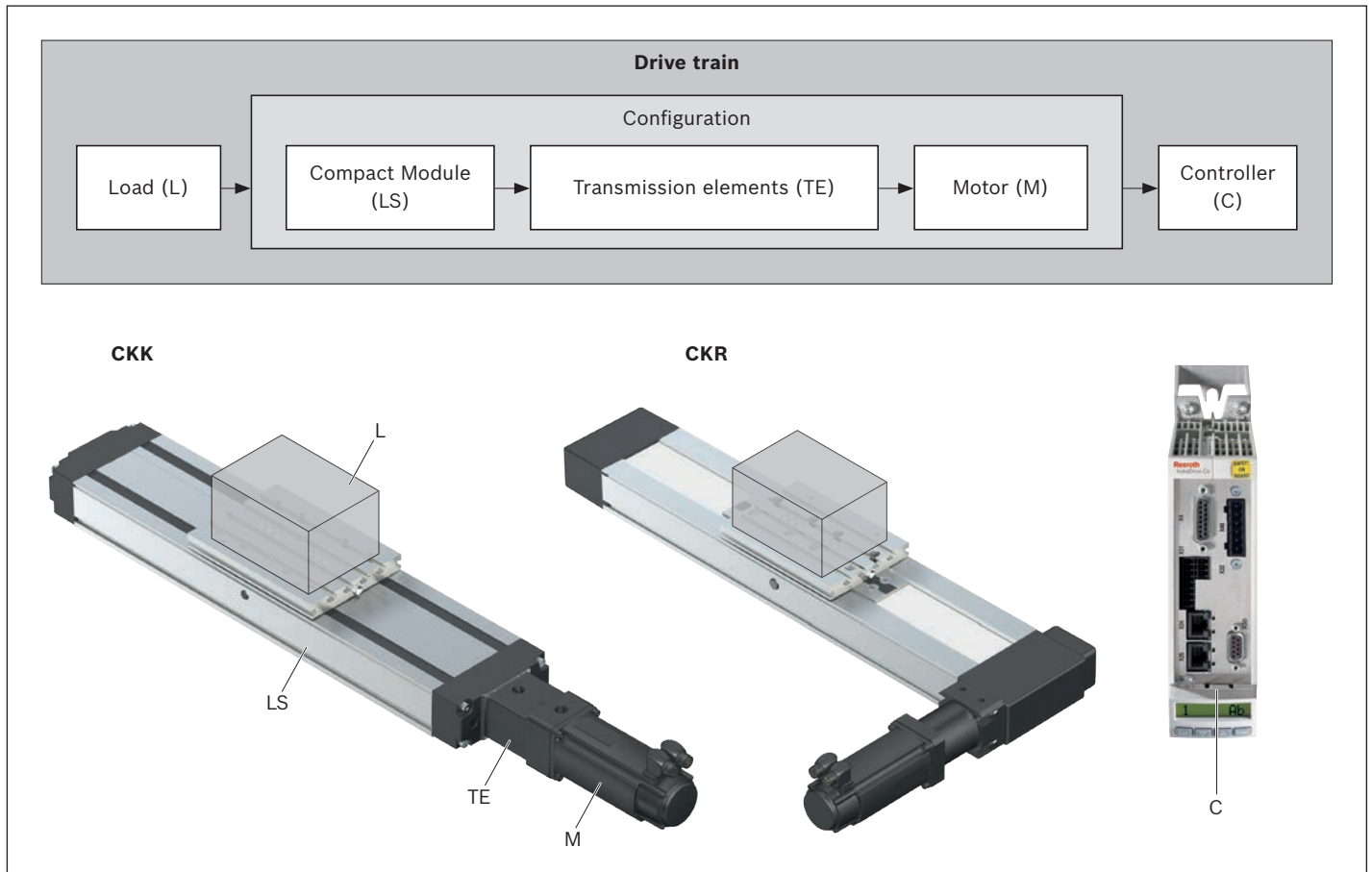

The correct dimensioning and assessment of an application requires structured consideration of the drive train as a whole.

The basic element of the drive train is the configuration – made up of the linear motion system, the transmission element (coupling, belt side drive or gear unit) and the motor – which can be ordered in that constellation in the catalog.

Basic principles

For drive dimensioning, the drive train can be divided into the mechanical system and drive system.

The **mechanical** system includes the physical components – linear motion system and the transmission elements (belt side drive, coupling) – and the load to be carried.

The electric **drive** is a motor-controller combination with corresponding performance data.

The dimensioning of the electric drive is done taking the motor shaft as a reference point.

For drive dimensioning, limits must be taken into account as well as base values. The limits must not be exceeded in order to avoid damaging the mechanical components.

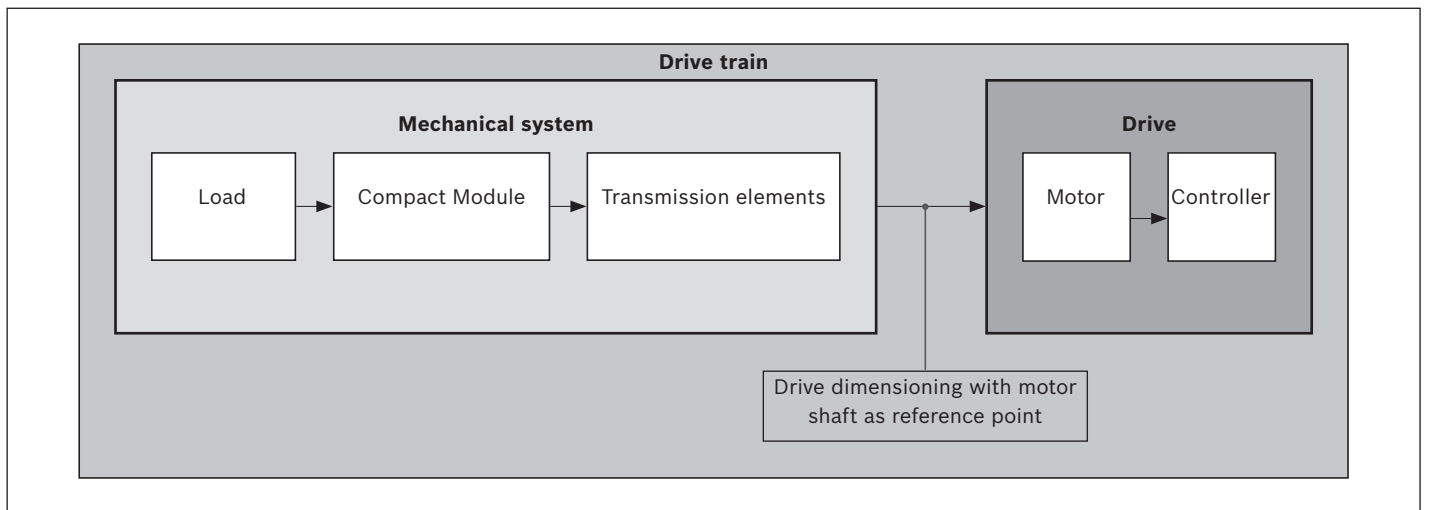

Technical data and formula symbols for the mechanical system

For every component (linear motion system, coupling, belt side drive, gear unit), the corresponding maximum permissible limits for drive torque and speed, and the base values for friction moment and mass moment of inertia have to be used.

The following technical data with the associated formula symbols are used when considering the basic **mechanical system** requirements in the design calculations for dimensioning the drive. The data listed in the table below can be found in the section titled "Technical Data" or is determined using formulas based on the descriptions on the following pages.

	Mechanical system				
	Load	Linear motion system	Transmission element		
			Coupling	Belt side drive	Gearing
Weight moment	(Nm)	$M_g^{5)}$	—	—	—
Frictional torque	(Nm)	— ⁴⁾	$M_{Rs}^{3)}$	—	$M_{Rge}^{3)}$
Mass moment of inertia	(kgm ²)	$J_t^{1)}$	$J_s^{2)}$	$J_c^{3)}$	$J_{sd}^{3)}$
Max. permissible speed	(m/s)	—	$v_{max}^{3)4)}$	—	—
Max. permissible rotary speed	(min ⁻¹)	—	$n_p^{1)}$	—	$n_{ge}^{3)}$
Max. permissible drive torque	(Nm)	—	$M_p^{3)4)}$	$M_{cN}^{3)}$	$M_{sd}^{3)}$

- ¹⁾ Determine the value using the appropriate formula
- ²⁾ Length-dependent value, determined using the appropriate formula
- ³⁾ Use the value from the table
- ⁴⁾ CKK: Length-dependent value, to be read off the graph
- ⁵⁾ Any additional process forces are to be taken into consideration as load moments
- ⁶⁾ For vertical mounting position: Determine the value using the appropriate formula

Drive dimensioning with motor shaft as reference point

When dimensioning the drive, all relevant design calculation values for the mechanical components in the drive train have to be determined and be expressed/reduced to the motor shaft. For a combination of mechanical components within the drive train, this will result in one value for each of the following:

- ▶ Frictional torque M_R
- ▶ Mass moment of inertia J_{ex}
- ▶ Maximum permissible speed v_{mech} (maximum permissible rotary speed n_{mech})
- ▶ Max. permissible drive torque M_{mech}

Determination of the values for each mechanical component in the drive train based on the motor shaft as a reference point

CKK Compact Modules	
Frictional torque M_R	
For motor attachment via flange and coupling	$M_R = M_{Rs}$
For motor attachment via belt side drive	$M_R = M_{Rsd} + \frac{M_{Rs}}{i}$
Mass moment of inertia J_{ex}	
For motor attachment via flange and coupling	$J_{ex} = J_s + J_t + J_c$
For motor attachment via belt side drive	$J_{ex} = J_{sd} + \frac{(J_s + J_t)}{i^2}$

CKR Compact Modules	
Frictional torque M_R	
For motor attachment via gear	$M_R = M_{Rge} + \frac{M_{Rs}}{i}$
Mass moment of inertia J_{ex}	
For direct motor attachment (without gear)	$J_{ex} = J_s + J_t$
For motor attachment via gear	$J_{ex} = J_{ge} + \frac{(J_s + J_t)}{i^2}$

Moment of inertia of the linear system

$$J_s = (k_{J \text{ fix}} + k_{J \text{ var}} \cdot L) \cdot 10^{-6}$$

Translatory mass moment of inertia of external load

$$J_t = m_{ex} \cdot k_{Jm} \cdot 10^{-6}$$

Maximum permissible speed v_{mech} or max. permissible rotary speed n_{mech}

The lowest of all the values for maximum permissible speed or rpm of all mechanical components contained in the drive train determines the maximum permissible speed of the mechanical system which has to be taken into consideration as the upper limit for the drive when sizing the motor.

Depending on the system, the maximum permissible speed/rotary speed of the linear motion system with Ball Screw Assembly is always below the limits for the coupling or belt side drive components, meaning it determines the maximum permissible speed of the mechanical system.

CKK Compact Modules

Maximum permissible speed

$$v_{\text{mech}} = v_{\text{max}}$$

Maximum permissible rotary speed

For motor attachment via flange and coupling

$$n_{\text{mech}} = \frac{v_{\text{mech}} \cdot 1\,000 \cdot 60}{P}$$

For motor attachment via belt side drive

$$n_{\text{mech}} = \frac{v_{\text{mech}} \cdot i \cdot 1\,000 \cdot 60}{P}$$

CKR Compact Modules

Maximum permissible speed

For direct motor attachment (without gear)

$$v_{\text{mech}} = v_{\text{max}}$$

$$v_{\text{mech}} = \frac{n_{\text{mech}} \cdot \pi \cdot d_3}{1000 \cdot 60}$$

For motor attachment via gear

$$v_{\text{mech}} = \frac{n_{\text{mech}} \cdot \pi \cdot d_3}{i \cdot 1\,000 \cdot 60}$$

Maximum permissible rotary speed

For direct motor attachment (without gear)

$$n_{\text{mech}} = \frac{v_{\text{mech}} \cdot 1\,000 \cdot 60}{\pi \cdot d_3}$$

$$n_{\text{mech}} = n_p$$

For motor attachment via gear

$$n_p = \frac{v_{\text{max}} \cdot 1\,000 \cdot 60}{\pi \cdot d_3}$$

$$n_{\text{mech}} = \text{minimum}(n_p \cdot i; n_{\text{ge}})$$

Maximum permissible drive torque M_{mech}

The lowest (minimum) of all the values for permissible drive torque of all mechanical components contained in the drive train determines the maximum permissible drive torque of the mechanical system which has to be taken into consideration as the upper limit for the drive when sizing the motor.

CKK Compact Modules

For motor attachment via flange and coupling

$$M_{\text{mech}} = \text{minimum} (M_{\text{cN}}; M_{\text{p}})$$

For motor attachment via belt side drive

$$M_{\text{mech}} = \text{minimum} (M_{\text{sd}}; \frac{M_{\text{p}}}{i})$$

CKR Compact Modules

For direct motor attachment (without gear)

$$M_{\text{mech}} = M_{\text{p}}$$

For motor attachment via gear

$$M_{\text{mech}} = \text{minimum} (\frac{M_{\text{ge}}}{i}; \frac{M_{\text{p}}}{i})$$

⚠ When considering the complete drive train (mechanical system + motor/controller), the maximum torque of the motor can lie below the maximum value for the mechanical system (M_{mech}) and thus limit the maximum permissible drive torque of the overall drive train.
If the maximum torque of the motor lies above the upper limit for the mechanical system (M_{mech}), the maximum motor torque must be limited to the permitted value for the mechanical system.

General motor preselection

The motor can be generally preselected using the following conditions.

Condition 1:

The rotary speed of the motor must be greater than or equal to the rotary speed required for the mechanical system (but not exceeding the maximum permissible limit value).

$$n_{\text{max}} \geq n_{\text{mech}}$$

Condition 2:

Consideration of the ratio of mass moments of inertia of the mechanical system and the motor. The ratio of the mass moments of inertia serves as an indicator for the control performance of a motor-controller combination. The mass moment of inertia of the motor is directly related to the motor size.

Ratio of mass moments of inertia

For preselection, experience has shown that the following ratios will result in high control performance. These are not rigid limits, but values exceeding them will require closer consideration of the specific application.

Application area	V
Handling	≤ 6.0
Processing	≤ 1.5

$$V = \frac{J_{ex}}{J_m + J_{br}}$$

Condition 3:

Estimation of the ratio of the static load moment to the continuous torque of the motor. The torque ratio must be less than or equal to an empirical value of 0.6. This condition roughly factors in the missing dynamic characteristics of an exact motion profile with the required motor torques.

Torque ratio

$$\frac{M_{stat}}{M_0} \leq 0.6$$

Static load moment

$$M_{stat} = M_R + M_g$$

CKK Compact Modules

Weight moment

For vertical mounting position only!

For motor attachment via flange
and coupling: $i = 1$

$$M_g = \frac{P \cdot (m_{ex} + m_{ca}) \cdot g}{2\,000 \cdot \pi \cdot i}$$

CKR Compact Modules

Weight moment

For vertical mounting position only!

$$M_g = \frac{d_3 \cdot (m_{ex} + m_{ca}) \cdot g}{2\,000 \cdot i}$$

In the section titled "Configuration and ordering", users can put together standard configurations, including motor attachment, gears and motor, for the various linear motion system sizes by selecting the appropriate options. By checking the above conditions, it is possible to see whether a standard motor selected in a particular configuration will generally be of a suitable size for the specific application.

Precise drive dimensioning

Preselecting the motor according to this rough guide is no substitute for the required precise design calculations for the drive, taking all moments/torques and rotary speed levels into account. For precise calculation of the electric drive, including consideration of the specific motion profile, please refer to the performance data in the catalog "Rexroth drive technology". When dimensioning the drive, the maximum permitted values for linear speed, drive torque and acceleration must not be exceeded, in order to avoid damaging the mechanical system.

Sample calculation CKK

Given data

In a handling task, a mass of 30 kg is to be moved horizontally by 500 mm at a travel speed of 0.5 m/s. The following was selected based on the technical data and the installation space:

Compact Modules CKK-110

- ▶ Carriage with connection plate
 $L_{ca} = 155 \text{ mm}$
- ▶ with cover strip
- ▶ Motor attachment via belt side drive, $i = 1.5$
- ▶ with motor MS2N04-B0BTN with brake

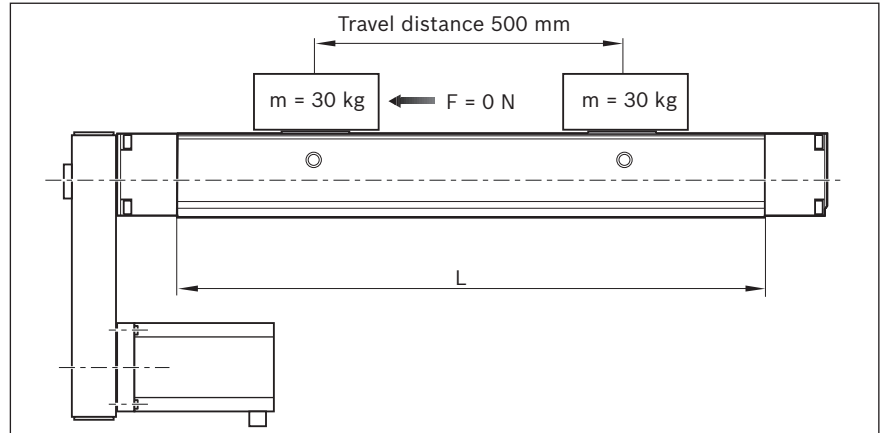

Estimation of length L

(For an initial estimate, the greatest possible lead and length are used for the calculation since the permissible velocity can decrease as length increases.)

	$L = s_{eff} + 2 \cdot s_e + L_{ca} + L_{ad}$
Excess travel:	$s_e = 2 \cdot P = 2 \cdot 16 = 32 \text{ mm}$
Max. travel:	$s_{max} = s_{eff} + 2 \cdot s_e$
	$= 500 + 2 \cdot 32 = 564 \text{ mm}$
Length:	$L = 564 + 155 + 20 = 739 \text{ mm}$

Selection of the Ball Screw Assembly

(Better to choose the lowest lead as this is favorable in terms of resolution, braking distance, length.)

Permissible Ball Screw Assembly according to the "Permissible speed" graph at $v = 0.5 \text{ m/s}$ and $L = 739 \text{ mm}$:

BASA 16 x 10 and BASA 16 x 16

Selected BASA (lower lead):

BASA 16 x 10

Maximum permissible speed for BASA 16 x 10 as read off from graph:

$$v_{max} = 0.77 \text{ m/s}$$

Calculation of length L

(For selected Ball Screw Assembly)

Excess travel:	$s_e = 2 \cdot P = 2 \cdot 10 = 20 \text{ mm}$
Max. travel:	$s_{max} = s_{eff} + 2 \cdot s_e$
	$= 500 + 2 \cdot 20 = 540 \text{ mm}$
Length:	$L = 540 + 155 + 20 = 715 \text{ mm}$

Friction moment M_R

(motor attachment via belt side drive)

$$M_R = M_{Rsd} + \frac{M_{Rs}}{i}$$

Compact module: $M_{Rs} = 0.43 \text{ Nm}$

Belt side drive: $M_{Rsd} = 0.40 \text{ Nm}$ ($i = 1.5$)

Frictional torque: $M_R = 0.40 + \frac{0.43}{1.5} = 0.69 \text{ Nm}$

Mass moment of inertia J_{ex}

(motor attachment via belt side drive)

$$J_{ex} = J_{sd} + \frac{(J_s + J_t)}{i^2}$$

Belt side drive: $J_{sd} = 82 \cdot 10^{-6} \text{ kgm}^2$

Compact Modules: $J_s = (k_{J_{fix}} + k_{J_{var}} \cdot L) \cdot 10^{-6}$
 $= (8.432 + 0.031 \cdot 715) \cdot 10^{-6}$
 $= 30.597 \cdot 10^{-6} \text{ kgm}^2$

External load: $J_t = m_{ex} \cdot k_{J_m} \cdot 10^{-6}$
 $= 30 \cdot 2.533 \cdot 10^{-6}$
 $= 75.99 \cdot 10^{-6} \text{ kgm}^2$

Mass moment of inertia: $J_{ex} = 82 \cdot 10^{-6} + \frac{(30.597 \cdot 10^{-6} + 75.99 \cdot 10^{-6})}{1.5^2}$
 $= 129.372 \cdot 10^{-6} \text{ kgm}^2$

Maximum permissible rotary speed n_{mech}

(motor attachment via belt side drive)

Limit for mechanical system

$$n_{mech} = \frac{(v_{mech} \cdot i \cdot 1\,000 \cdot 60)}{p}$$

Max. permissible speed: $v_{mech} = v_{max} = 0.77 \text{ m/s}$

Max. permissible rotary speed: $n_{mech} = \frac{(0.77 \cdot 1.5 \cdot 1\,000 \cdot 60)}{10}$
 $= 6\,930 \text{ min}^{-1}$

Maximum rotary speed of application n_{mech}

(motor attachment via belt side drive)

Application tolerance

Travel speed: $v_{mech} = 0.5 \text{ m/s}$

Rotary speed: $n_{mech} = \frac{0.5 \cdot 1.5 \cdot 1\,000 \cdot 60}{10}$
 $= 4\,500 \text{ min}^{-1}$

Sample calculation CKK

Maximum permissible drive torque M_{mech}
(motor attachment via belt side drive)
Limit for mechanical system

$$M_{\text{mech}} = \text{Minimum} \left(M_{\text{sd}}; \frac{M_{\text{p}}}{i} \right)$$

Belt side drive: $M_{\text{sd}} = 5.11 \text{ Nm}$ (gear ratio $i = 1.5$ for MS2N04-C0BTN)

Compact Modules: $M_{\text{p}} = 13.51 \text{ Nm}$

Drive torque: $M_{\text{mech}} = \text{Minimum} \left(5.11; \frac{13.51}{1.5} \right)$
 $= \text{Minimum} (5.11; 9.0)$
 $= 5.11 \text{ Nm}$

Motor preselection check

Selected motor:
MS2N04-C0BTN with brake

Condition 1:

Rotary speed: $n_{\text{max}} \geq n_{\text{mech}}$
 $6,000 \geq 4500$ condition met – motor selection OK

Condition 2:

Mass moment of inertia ratio: $V = \frac{J_{\text{ex}}}{J_{\text{m}} + J_{\text{br}}}$

Motor inertia: $J_{\text{m}} = 110 \cdot 10^{-6} \text{ kgm}^2$

Brake moment of inertia: $J_{\text{br}} = 50 \cdot 10^{-6} \text{ kgm}^2$

Moment of inertia ratio: $V = \frac{129.372 \cdot 10^{-6}}{(110 \cdot 10^{-6} + 50 \cdot 10^{-6})} = 0.81$

Handling condition: $V \leq 6$
 $0.81 \leq 6$ condition met
 – motor selection OK

Condition 3:

Torque ratio: $\frac{M_{\text{stat}}}{M_0} \leq 0.6$

Static load moment: $M_{\text{stat}} = M_{\text{R}} + M_{\text{g}}$ (installed horizontally $M_{\text{g}} = 0$)
 $= 0.69 \text{ Nm}$

Continuous motor torque: $M_0 = 2.8 \text{ Nm}$

Torque ratio: $\frac{0.69}{2.8} = 0.25$
 $0.25 \leq 0.6$ condition met
 – motor selection OK

All three conditions met ⇒ selected motor is suitable for the application.

Result

Compact Module CKK-110

Length: $L = 715 \text{ mm}$
 Max. travel: $s_{\max} = 540 \text{ mm}$
 Carriage length: $L_{\text{ca}} = 155 \text{ mm}$
 Ball Screw Assembly: Nominal diameter: $d_0 = 16 \text{ mm}$
 Lead: $P = 10 \text{ mm}$

with cover strip

Motor attachment via belt side drive, gear ratio $i = 1.5$

Motor preselection: MS2N04-B0BTN with brake

For precise dimensioning of the electric drive, the motor-controller combination must always be considered, as the performance data (e.g. max. useful speed and max. torque) will depend on the controller used.

When doing this, the following data must be considered:

Frictional torque: $M_R = 0.69 \text{ Nm}$
 Mass moment of inertia: $J_{\text{ex}} = 129.372 \cdot 10^{-6} \text{ kgm}^2$
 Travel speed: $v_{\text{mech}} = 0.5 \text{ m/s}$ ($n_{\text{mech}} = 4\,500 \text{ min}^{-1}$)
 Drive torque limit: $M_{\text{mech}} = 5.11 \text{ Nm}$

⇒ The motor torque must be limited to 5.11 Nm on the drive side!

Acceleration limit: $a_{\max} = 50 \text{ m/s}^2$
 Limit for travel speed: $v_{\max} = 0.77 \text{ m/s}$ ($n_{\text{mech}} = 6\,930 \text{ min}^{-1}$)

Besides the preferred type MS2N04-B0BTN, other motors with identical connection dimensions can be adapted while taking care not to exceed the calculated limit values.

Sample calculation CKR

Given data

In a handling task, a mass of 25 kg is to be moved horizontally by 1000 mm at a travel speed of 1.5 m/s. The following was selected based on the technical data and the installation space:

Compact Module CKR-145

- ▶ Carriage length = 190 mm
- ▶ With connection plate
- ▶ Motor attachment via planetary gearbox, $i = 5$
- ▶ with motor MS2N04-D0BQN without brake

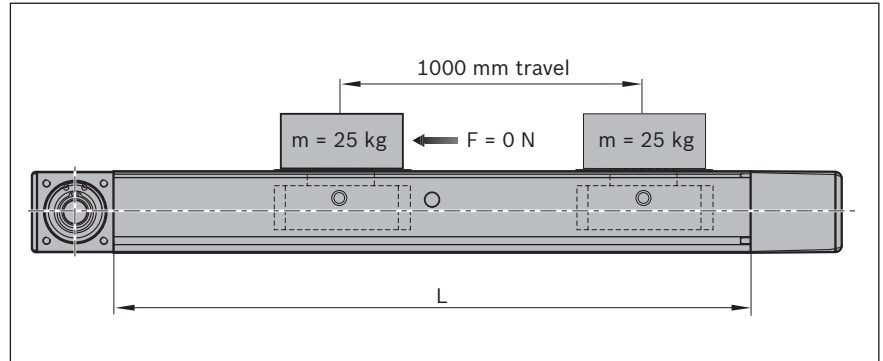

Calculation of length L

(In most cases, the recommended limit for excess travel is 2x feed constant. The excess travel must be greater than the emergency stop stopping distance, which is calculated for exact dimensioning of the electrical drive.)

$$\begin{aligned}
 L &= s_{\max} + L_{ca} + L_{ad} \\
 \text{Feed constant: } u &= \frac{u(i=1)}{i} \\
 &= \frac{165}{5} = 33 \text{ mm} \\
 \text{Excess travel: } s_e &= 2 \cdot u = 2 \cdot 33 = 66 \text{ mm} \\
 \text{Max. travel: } s_{\max} &= s_{\text{eff}} + 2 \cdot s_e \\
 &= 1000 + 2 \cdot 66 = 1132 \text{ mm} \\
 \text{Length: } L &= 1132 + 190 + 75 = 1397 \text{ mm}
 \end{aligned}$$

Frictional torque M_R

$$\begin{aligned}
 M_R &= M_{Rge} + \frac{M_{Rs}}{i} \\
 \text{Compact Module: } M_{Rs} &= 2.04 \text{ Nm} \\
 \text{Gear: } M_{Rge} &= 0.17 \text{ Nm} \\
 \text{Frictional torque: } M_R &= 0.17 + \frac{2.04}{5} = 0.58 \text{ Nm}
 \end{aligned}$$

Mass moment of inertia J_{ex}

$$\begin{aligned}
 J_{ex} &= J_{ge} + \frac{(J_s + J_t)}{i^2} \\
 \text{Gear: } J_{ge} &= 27 \cdot 10^{-6} \\
 \text{Compact Module: } J_s &= (k_{J \text{ fix}} + k_{J \text{ var}} \cdot L) \cdot 10^{-6} \\
 &= (2276.71 + 0.3172 \cdot 1397) \cdot 10^{-6} \\
 &= 2719.838 \cdot 10^{-6} \text{ kgm}^2 \\
 \text{External load: } J_t &= m_{ex} \cdot k_{Jm} \cdot 10^{-6} \\
 &= 25 \cdot 689.59 \cdot 10^{-6} \\
 &= 17239.75 \cdot 10^{-6} \text{ kgm}^2 \\
 \text{Mass moment} \\
 \text{of inertia: } J_{ex} &= 27 \cdot 10^{-6} + \frac{(2719.838 \cdot 10^{-6} + 17239.75 \cdot 10^{-6})}{5^2} \\
 &= 825.384 \cdot 10^{-6} \text{ kgm}^2
 \end{aligned}$$

Maximum permissible rotary speed n_{mech}

(Motor attachment via gear reducer,
without considering the motor)

Limit for mechanical system

$$n_{\text{mech}} = \text{Minimum} (n_p \cdot i ; n_{\text{ge}})$$

Compact Module: $n_p = \frac{(v_{\text{max}} \cdot 1\,000 \cdot 60)}{\pi \cdot d_3}$

$$= \frac{(5 \cdot 1\,000 \cdot 60)}{\pi \cdot 52.52}$$

$$= 1\,818 \text{ min}^{-1}$$

Gear: $n_{\text{ge}} = 8\,000 \text{ min}^{-1}$

Max. permissible rotary speed: $n_{\text{mech}} = \text{Minimum} (1\,818 \cdot 5 ; 8\,000)$

$$= \text{Minimum} (9\,090 ; 8\,000)$$

$$= 8\,000 \text{ min}^{-1}$$

Maximum permissible speed v_{mech}

(Motor attachment via gear reducer,
without considering the motor)

Limit for mechanical system

$$v_{\text{mech}} = \frac{(n_{\text{mech}} \cdot \pi \cdot d_3)}{i \cdot 1\,000 \cdot 60}$$

Max. permissible speed: $v_{\text{mech}} = \frac{(8\,000 \cdot \pi \cdot 52.52)}{5 \cdot 1\,000 \cdot 60}$

$$= 4.4 \text{ m/s}$$

Maximum permitted speed of the application n_{mech}

(Motor attachment via gear reducer,
without considering the motor)

Application tolerance

Travel speed: $v_{\text{mech}} = 1.5 \text{ m/s}$

Rotary speed: $n_{\text{mech}} = \frac{(1.5 \cdot 5 \cdot 1\,000 \cdot 60)}{\pi \cdot 52.52}$

$$= 2\,727 \text{ min}^{-1}$$

Maximum permissible drive torque M_{mech}

(Motor attachment via gear reducer,
without considering the motor)

Limit for mechanical system

$$M_{\text{mech}} = \text{Minimum} \left(\frac{M_{\text{ge}}}{i} ; \frac{M_p}{i} \right)$$

Compact Module: $M_p = 32.5 \text{ Nm}$

Gear: $M_{\text{ge}} = 40 \text{ Nm}$

Drive torque: $M_{\text{mech}} = \text{Minimum} \left(\frac{40}{5} ; \frac{32.5}{5} \right)$

$$= \text{Minimum} (8.0 ; 6.5)$$

$$= 6.5 \text{ Nm}$$

Sample calculation CKR

Motor preselection check

Selected motor:

MS2N04-D0BQN without brake

Condition 1:

Rotary speed: $n_{\max} \geq n_{\text{mech}}$

$6,000 \geq 2727$ condition met – motor selection OK

Condition 2:

Mass moment of inertia ratio: $V = \frac{J_{\text{ex}}}{J_m + J_{\text{br}}}$

Motor inertia: $J_m = 160 \cdot 10^{-6} \text{ kgm}^2$

Brake moment of inertia: $J_{\text{br}} = 0 \text{ kgm}^2$ (without brake)

Moment of inertia ratio: $V = \frac{825.384 \cdot 10^{-6}}{160 \cdot 10^{-6}}$
 $= 5.16$

Handling condition: $V \leq 6$

$5.16 \leq 6$ condition met

– motor selection OK

Condition 3:

Torque ratio: $\frac{M_{\text{stat}}}{M_0} \leq 0.6$

Static load moment: $M_{\text{stat}} = M_R + M_g$ (installed horizontally $M_g = 0$)

$\frac{0.58}{3.85} = 0.58 \text{ Nm}$

Continuous motor

torque: $M_0 = 3.85 \text{ Nm}$

Torque ratio: $= 0.15$

$0.15 \leq 0.6$ condition met

– motor selection OK

All three conditions met ⇒ selected motor is suitable for the application.

Result

Compact Module CKR-145

Length $L = 1\,397\text{ mm}$
 Max. travel $s_{\max} = 1\,132\text{ mm}$
 Carriage length $L_{\text{ca}} = 190\text{ mm}$

Belt drive

With connection plate

Motor attachment via planetary gearbox, gear ratio $i = 5$

Motor preselection: MS2N04-D0BQN without brake

For precise dimensioning of the electric drive, the motor-controller combination must always be considered, as the performance data (for example, maximum useful speed and maximum torque) will depend on the controller used.

When doing this, the following data must be considered.

Frictional torque $M_R = 0.58\text{ Nm}$
 Mass moment of inertia $J_{\text{ex}} = 825.384 \cdot 10^{-6}\text{ kgm}^2$
 Travel speed $v_{\text{mech}} = 1.5\text{ m/s}$ ($n_{\text{mech}} = 2\,727\text{ min}^{-1}$)
 Drive torque limit $M_{\text{mech}} = 6.5\text{ Nm}$

➡ The motor torque must be limited to 6.5 Nm on the drive side!

Acceleration limit $a_{\max} = 50\text{ m/s}^2$
 Limit for travel speed $v_{\max} = 3.3\text{ m/s}$ ($n_{\max} = 6\,000\text{ min}^{-1}$)

After determining the emergency-stop braking path during precise dimensioning, the selected excess travel must be checked to see whether it is sufficient and adjusted if necessary.

Besides the preferred type MS2N04-D0BQ, other motors with identical connection dimension can be adapted while taking care not to exceed the calculated limits.

Abbreviations

Abbreviation/ index	Designation	Unit
a	Acceleration	(m/s ²)
a_{max}	Maximum acceleration	(m/s ²)
BASA	Ball Screw Assembly	(–)
B_t	Belt type	(–)
c_{spe}	Specific spring rate	(N)
C_{gw}	Dynamic load capacity, guideway	(N)
C_{bs}	Dynamic load capacity for Ball Screw Assembly	(N)
C_{fb}	Dynamic load capacity for fixed bearing	(N)
d₀	Nominal diameter of Ball Screw Assembly	(mm)
d₃	Belt pulley diameter	(mm)
f_w	Load factor	(–)
F_n	Axial load of the Ball Screw Assembly	(N)
F_{eff}	Effective equivalent axial load	(N)
F_{bp}	Max. belt driving force	(N)
F_{comb}	Combined equivalent bearing load	(N)
F_{mbs}	Dynamic equivalent load on bearing of the Ball Screw Assembly	(N)
F_{mgw}	Dynamic load on bearing of the guideway	(N)
F_n	Axial load of the Ball Screw Assembly	(N)
F_{t perm}	Belt elasticity limit	(N)
F_y	Load from a resulting force in y-direction	(N)
F_{y max}	Max. dynamic load in y-direction	(N)
F_z	Load from a resulting force in z-direction	(N)
F_{z max}	Max. dynamic load in z-direction	(N)
g	Gravity (= 9.81)	(m/s ²)
i	Gear ratio	(–)
I_y	Planar moment of inertia about the y-axis	(cm ⁴)
I_z	Planar moment of inertia about the z-axis	(cm ⁴)
J_{br}	Mass moment of inertia of the motor brake	(kgm ²)
J_c	Mass moment of inertia of coupling	(kgm ²)
J_{dc}	Mass moment of inertia of drive train	(kgm ²)
J_{ex}	Mass moment of inertia of the mechanical system	(kgm ²)
J_{ge}	Mass moment of inertia of gear about the motor journal	(kgm ²)
J_m	Mass moment of inertia of motor	(kgm ²)
J_s	Mass moment of inertia of linear motion system	(kgm ²)
J_{sd}	Mass moment of inertia of belt side drive about the motor journal	(kgm ²)
J_t	Translatory mass moment of inertia of external load based on the linear motion system screw journal	(kgm ²)
k_{g fix}	Constant for fixed portion of mass	(kg)
k_{g var}	Constant for variable-length portion of mass	(kg/mm)
k_{J fix}	Constant for fixed portion of mass moment of inertia	(kgmm ²)

Abbreviation/ index	Designation	Unit
k_{J m}	Constant for mass-specific portion of mass moment of inertia	(mm ²)
k_{J var}	Constant for variable-length portion of mass moment of inertia	(kgmm)
L	Length of the linear motion system	(mm)
L_{ad}	Additional length	(mm)
L_{ca}	Carriage length	(mm)
L_{bs}	Nominal life (Ball Screw Assembly, fixed bearing)	(min ⁻¹)
L_{hbs}	Nominal life (Ball Screw Assembly, fixed bearing)	(h)
L_{gw}	Nominal life of the guideway	(m)
L_{hgw}	Nominal life of the guideway	(h)
L_m	Motor length	(mm)
L_{max}	Max. length	(mm)
L_w	Center-to-center distance between carriages	(mm)
m_{br}	Holding brake mass	(kg)
m_{ca}	Moved system mass of carriage	(kg)
m_{ex}	Moved external mass	(kg)
m_{fc}	Mass of flange and coupling	(kg)
m_m	Motor mass	(kg)
m_s	Mass of the linear motion system (without attachments)	(kg)
m_{sd}	Mass of belt side drive	(kg)
M₀	Continuous motor torque	(Nm)
M_{cN}	Nominal coupling torque	(Nm)
M_g	Weight moment at motor journal	(Nm)
M_{ge}	Maximum permissible acceleration torque of the gear (on the output drive)	(Nm)
M_L	Dynamic longitudinal moment load capacity	(Nm)
M_m	Equivalent dynamic torque	(Nm)
M_{max}	Max. possible motor torque	(Nm)
M_{mech}	Max. permissible drive torque for the mechanical system	(Nm)
M_p	Max. permissible drive torque (at the drive journal)	(Nm)
M_R	Frictional torque at motor journal	(Nm)
M_{Rge}	Frictional torque of gear at motor journal	(Nm)
M_{Rs}	Frictional torque of system	(Nm)
M_{Rsd}	Friction moment of belt side drive at motor journal	(Nm)
M_{sd}	Maximum permissible drive torque of the belt side drive	(Nm)
M_{stat}	Static load moment	(Nm)
M_t	Dynamic torsional moment load capacity	(Nm)
M_x	Dynamic torsional moment around the x-axis	(Nm)
M_{x max}	Maximum permissible torsional moment around the x-axis	(Nm)

Abbreviation/ index	Designation	Unit
M_y	Dynamic torsional moment around the y-axis	(Nm)
$M_{y \max}$	Maximum permissible torsional moment around the y-axis	(Nm)
M_z	Dynamic torsional moment around the z-axis	(Nm)
$M_{z \max}$	Maximum permissible torsional moment around the z-axis	(Nm)
n	Rotary speed of the Ball Screw Assembly	(min^{-1})
n_1, n_2, \dots, n_n	Rotary speed in acceleration and braking phases	(min^{-1})
$n_{A1 \dots n}$	Starting speed in Phase 1–n	(min^{-1})
$n_{E1 \dots n}$	Ending speed in Phase 1–n	(min^{-1})
n_{ge}	Maximum permissible rotary speed of the gear	(min^{-1})
n_m	Mean rotary speed of the Ball Screw Assembly	(min^{-1})
n_{mech}	Maximum permissible speed of mechanical system	(min^{-1})
n_{\max}	Max. motor speed	(min^{-1})
n_p	Maximum permissible rotary speed of the linear motion system	(min^{-1})
P	Screw lead	(mm)
P_{app}	Effective power in application	(W)
Keyway	Keyway	(–)
$q_{t1 \dots n}$	Time step of the phases	(%)
s_a	Acceleration travel	(mm)
s_e	Excess travel (excess travel s_e should be greater than braking distance. The acceleration travel can be used as a guideline for braking distance.)	(mm)
s_{eff}	Effective stroke	(mm)
s_{\min}	Min. travel range	(mm)
s_{\max}	Max. travel distance	(mm)
Screw support	Screw support	
t_a	Acceleration time, braking time	(s)
t_1, t_2, \dots, t_n	Time for phase 1 ... n	(s)
u	Feed constant	(mm/rev)
v_1, v_2, \dots, v_n	Speed in phase 1 ... n	(m/s)
v_{\max}	Maximum permissible speed	(m/s)
v_{mech}	Maximum permissible speed for mechanical system	(m/s)
v_{mgw}	Mean speed of the guideway	(m/s)
V	Ratio of mass moments of inertia of drive train and motor	(–)
z_1	Application point of the effective force	(mm)

Order example CKK-110-NN-1

Ordering data		Description
Compact Module	CKK-110-NN-1	Compact Module CKK110-NN-1
Length L	715	Length = 715 mm
Version	RV01	Belt side drive
Lubrication	LSS	Lubrication version LSS
Drive		
Ball Screw Assembly (BASA d ₀ x P)	02	Nominal diameter = 16 mm, lead = 10 mm
Carriage		
Carriage ¹⁾	41	Carriage with connection plate, L _{ca} = 155 mm
Carriage center-to-center distance L _w	-	only necessary with carriages with variable center-to-center distance
Motor attachment		
Gear ratio	-	without gear ratio
Attachment kit ²⁾	23	Motor attachment for servo motor MS2N04-B0BTN
Motor		
Motor code	212	MS2N03-B0BTN, 1 cable, with brake
Motor connector position	270	Motor connector position = 270°
Cover		
Cover	02	with cover strip
Switching system (max. 6 switches/sensors selectable)		
1st sensor	21	REED, changeover contact (NC: C+NC, NO: C+NO)
2nd sensor	22	Hall, PNP normally closed (NC)
3rd sensor	21	REED, changeover contact (NC: C+NC, NO: C+NO)
Mounting duct / cable duct	25	Mounting channel
Socket-plug	17	Socket-plug
Documentation	01	Standard report

¹⁾ for the permissible values refer to the "General technical data"

²⁾ The motor geometry code is required for motors according to customer specifications

Inquiry/order form CKK-xxx-NN-1

Ordering data		Description
Compact module		
Length L		
Version		
Lubrication		
Drive		
Ball Screw Assembly (BASA d ₀ x P)		
Carriage		
Carriage ¹⁾		
Carriage center-to-center distance L _w		
Motor attachment		
Gear ratio		
Attachment kit ²⁾		
Motor		
Motor code		
Motor connector position		
Cover		
Cover		
Switching system		
1st sensor		
2nd sensor		
3rd sensor		
Mounting duct / cable duct		
Socket-plug		
Documentation		

¹⁾ for the permissible values refer to the "General technical data"
²⁾ The motor geometry code is required for motors according to customer specifications

Motor attachment kits according to customer specification (motor geometry code)

The dimensions queried result in a unique "motor geometry code":

□□ - □□ - □□□ - □□□ - □□□ - **M**□□□ - □□□□ - □□□□

∅D	=	Shaft diameter
C	=	Shaft length
∅E	=	Centering diameter
C₁	=	Centering depth
∅F	=	Pitch diameter
∅G	=	Through-hole for mounting screw (specify thread diameter)
B₁	=	Flange thickness
A	=	Flange edge dimension

Quantity Acceptance of: ____ pcs, ____ per month, ____ per year, per order, or _____
Comments: _____

From
 Company: _____ Name: _____
 Address: _____ Department: _____
 _____ Phone: _____
 _____ Telefax: _____

Further information

Bosch Rexroth homepage:

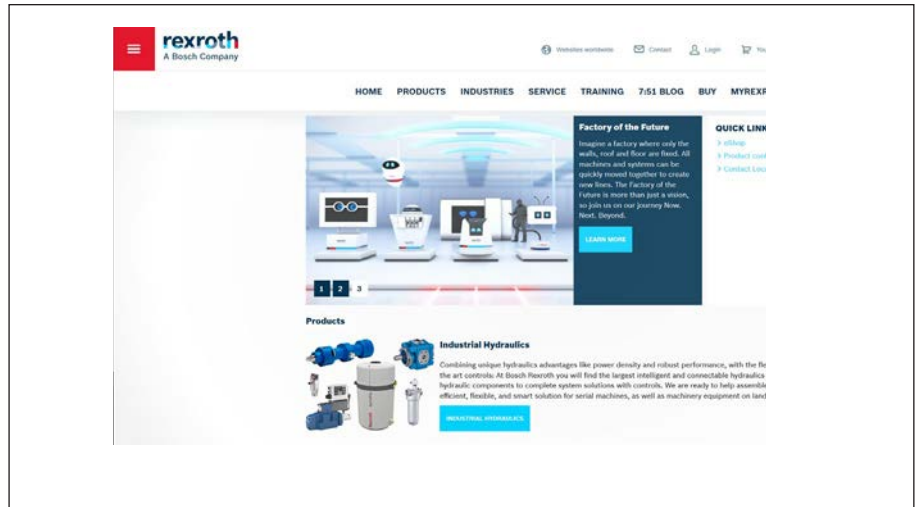

Compact module product information:

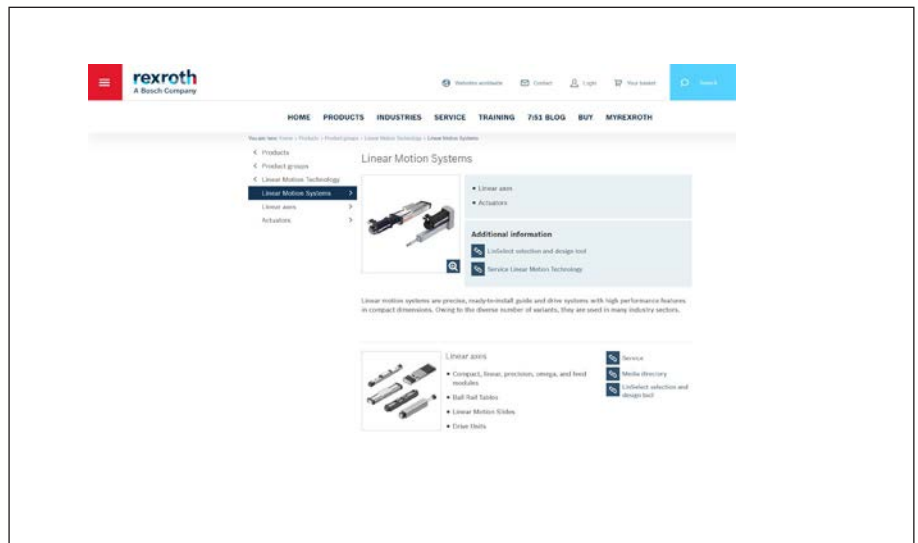

GoTo Europe:

GoTo Europe Focused Delivery Program
Going to your product in only three steps:

1. Select the product
2. View the product data
3. Order the product

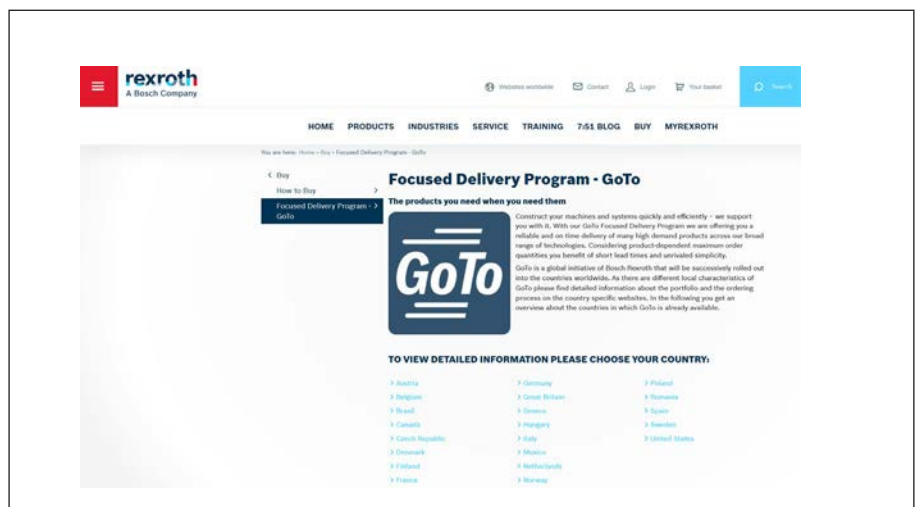

Configurators and tools:



The screenshot shows the 'Konfiguratoren und Tools' page on the Rexroth website. The page features a navigation menu at the top with options like HOME, PRODUKTE, BRANCHEN, SERVICE, TRAINING, TRENDS UND THEMEN, SO KAUFEN SIE, and MYREXROTH. Below the navigation, there is a breadcrumb trail: Home > Produkte > Produktsupport > Konfiguratoren und Tools. The main heading is 'Konfiguratoren und Tools', followed by a sub-heading: 'Nutzenorientiert, übersichtlich und umfassend bietet Rexroth damit eine Vielzahl an Hilfsmitteln, um die Identifikation bzw. Konfiguration passender Produktlösungen zu unterstützen.' Below this, there is a paragraph: 'Von der Auswahl vorhandener Standardprodukte über die individualisierte Variantenerstellung bis hin zur Durchsicherung der Engineering & Beschaffungsprozesse können Sie aus einem umfangreichen Toolportfolio wählen.' The page is divided into two main sections: 'Produktkonfiguratoren' and 'Engineering Tools'. Under 'Produktkonfiguratoren', there is a list of features: 'Hand von der Uhr erreichbar', 'Unabhängige Konfigurationsdokumentation (einschließlich CAD-Daten)', and 'Konfiguration über Materialnummern, Typenbezeichnung oder Funktion'. Under 'Engineering Tools', there is a list of features: 'Erweiterte Funktionen (Planung, Konstruktions, Berechnung...)', 'Offline-Verfügbarkeit', and 'Support beim Einkaufsprozess'. At the bottom of the page, there is a vertical menu with categories: ALGEMEIN, MONTAGETECHNIK, ELEKTRISCHE ANTRIEBE UND STEUERUNGEN, INDUSTRIEHYDRAULIK, and LINEARTECHNIK, each with a plus sign to its right.

Notes

Bosch Rexroth AG

Ernst-Sachs-Straße 100
97424 Schweinfurt, Germany
Tel. +49 9721 937-0
Fax +49 9721 937-275
www.boschrexroth.com

You can find your local contacts at:

www.boschrexroth.com/contact

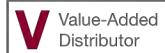
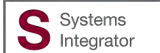
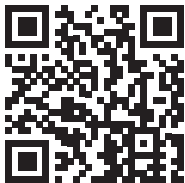

248-373-1600 • morrell-group.com • orders@morrellinc.com

MI • IN • IL • OH • ON, CAN

MorrellGroup 
Evolution in Controls