

IndraMotion MTX micro – the compact CNC system

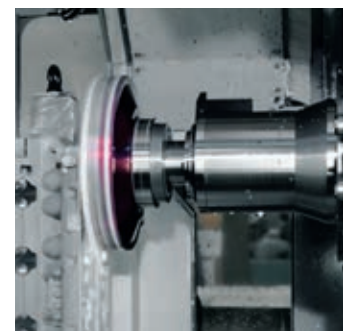

IndraMotion MTX micro – profitability with complete functional range

The market for CNC machine tools is very diverse and many machine tool builders have requirements for low-cost control and drive solutions for standard turning and milling machines. CNC system IndraMotion MTX micro from Rexroth is the ideal tool for these applications and is exceptionally affordable.



IndraMotion MTX micro is the compact, simple, powerful, and nevertheless low-cost CNC solution from Rexroth for standard turning and milling machines. It consists of a custom HMI interface and a compact multi-axis drive controller with high-capacity CNC control and PLC.

Advantage

- ▶ Easy to use and practical
- ▶ Ultra-high reliability and production accuracy – down to the nanometer
- ▶ Machining times minimized thanks to a high-performance processor
- ▶ Fast, easy commissioning of the turnkey system
- ▶ Compact multi-axis drive controller with small footprint that needs minimal mounting space in control cabinet
- ▶ Direct connection to 200 - 500 V, 50 - 60 Hz supply mains without a transformer

All of these advantages make IndraMotion MTX micro the most compact and high-performance CNC in its class.

Features

- ▶ Operating Panels and software optimized for easy and efficient machine operation
- ▶ Comprehensive technology-cycle library for easy, efficient solving of complex machining tasks
- ▶ Multiple technological functions for complete machining
- ▶ Compatible with the standard, performance and advanced versions of IndraMotion MTX
- ▶ Preconfigured software for turning and milling
- ▶ Open PLC per IEC 61131-3 for application-specific enhancements
- ▶ Engineering tools for easy, fast commissioning and diagnosis

IndraMotion MTX micro – the perfect CNC system for

- ▶ Turning, milling and drilling
- ▶ Turning and machining centres
- ▶ Grinding
- ▶ Gear machining

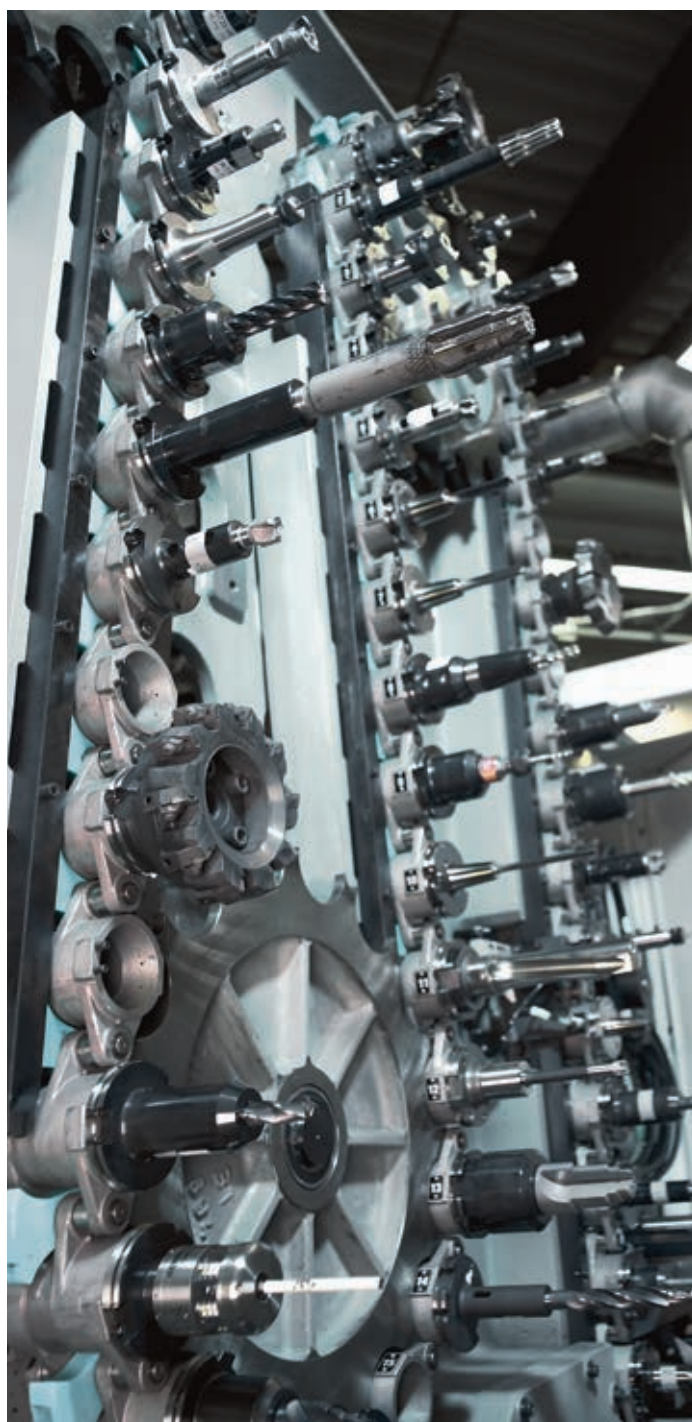

Turning – precise and complete

IndraMotion MTX micro offers all functionality for the standard turning machine without any requirements for additional software options:

- ▶ Constant surface speed
- ▶ Tapping with or without compensating chuck
- ▶ Spindle turret axis
- ▶ Turning, drilling and milling cycles for complete machining

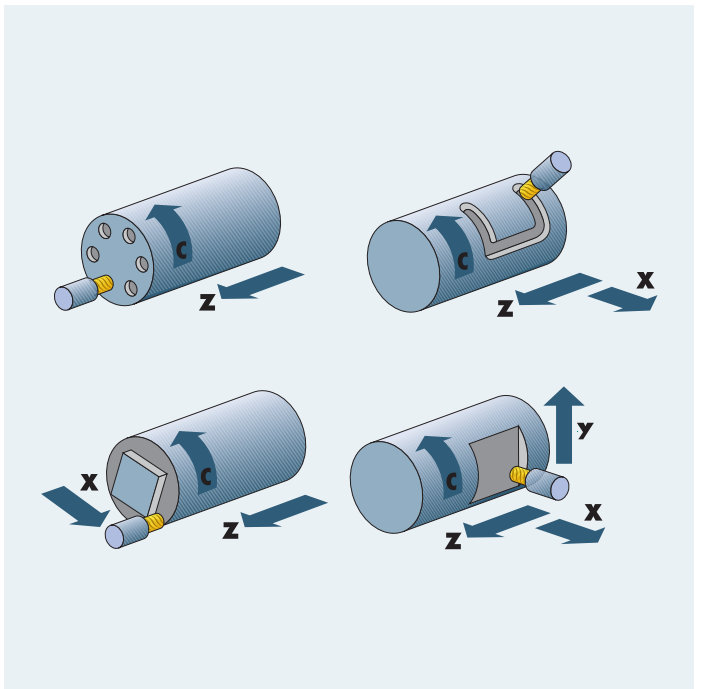

- ▲ **HMI Panel IndraControl VDP81**
 - Brilliant color TFT display (10,4")
 - Front USB memory interface
 - ASCII keyboard
 - IP54 front protection
- ▲ **Machine Operator Panel IndraControl VAM81**
 - Flexible labeling of the operating keys
 - Feedrate & spindle override, Start/Stop button
 - E-Stop switch, 2 Handwheel interfaces
 - 16 digital inputs / 8 digital outputs

- ▲ **Drilling and milling functions for complete machining**
 - C axis machining with live tools
 - Cylinder surface machining
 - End-face machining

Milling – quick and efficient

IndraMotion MTX micro covers the complete range for the standard milling machines:

- ▶ 2.5D and 3D machining using up to 5 interpolating axes
- ▶ Direct programming using drawing dimensions
- ▶ Free positioning of the workpiece coordinate system in space
- ▶ Drilling, milling and turning cycles for complete machining

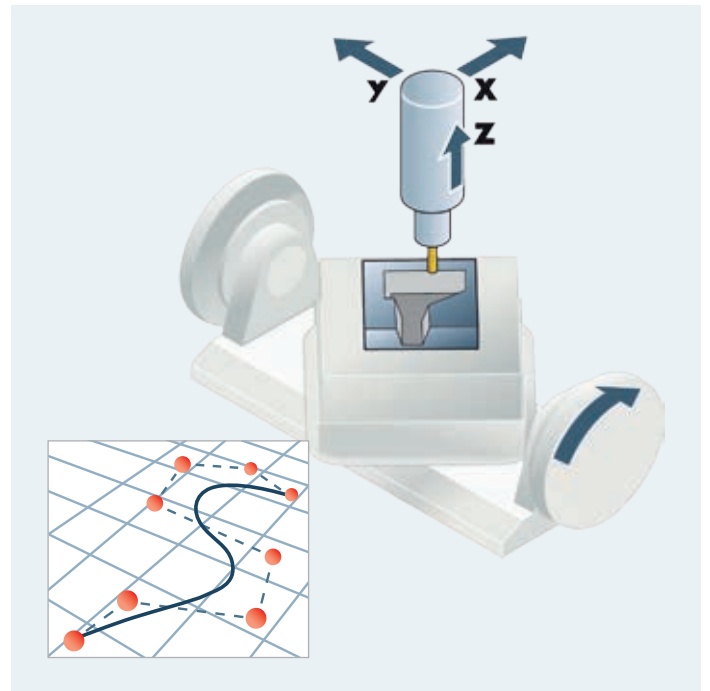

- ▲ **HMI Panel IndraControl VDP82**
 - Brilliant color TFT display (10,4“)
 - Front USB memory interface
 - ASCII keyboard
 - IP54 front protection
- ▲ **Machine Operator Panel IndraControl VAM82**
 - Flexible labeling of the operating keys
 - Feedrate & spindle override, Start/Stop button
 - E-Stop switch, 2 Handwheel interfaces
 - 16 digital inputs / 8 digital outputs

- ▲ **Functions for highly precise, fast machining**
 - Axis-specific jerk limitation
 - 1,000 NC blocks with look-ahead function
 - Spline interpolation
 - B-spline compressor
 - Nanometer interpolation

User friendly operation and programming

The IndraControl VDP and VAM operating panels for IndraMotion MTX micro include complete functionality including visualization, operation and programming in a user friendly package. The panels are available as horizontal (VDP81, VAM81) and vertical (VDP82, VAM82) variants. In addition there is the all-in-one panel VDP80 for compact lathes.

▼ IndraControl VDP82

▼ IndraControl VAM82



USB port

Soft-keys for controlling the current operating area

ASCII keyboard for programming

Direct selection of the operating area

Robust 22 mm buttons for E-STOP, Start and Stop

36 machine operation keys with flexible labeling

Override switches for spindle and feedrate



- ▶ **IndraControl VDP and VAM machine operating panels**
- Brilliant display
- Ergonomic design
- Robust IP65 front
- Minimum wiring



The software assists the operator in all tasks by providing intuitive dialog screens, e.g.:

- ▶ Set-up the machine
- ▶ Prepare the tools
- ▶ Develop and process the NC programs
- ▶ Change parameters
- ▶ Diagnose problems

Standard languages are German, English and Chinese, with additional languages available upon request. Convenient editor functions facilitate NC programming as well as program testing and optimizing. The user interface is available in multiple languages, which can be toggled without having to restart the control system.

An user administration facility enables access to be restricted to specific functions so that the machine can be operated safely and reliably. Alarms and messages are output in plain text and documented in the integrated logbook.



Selected operating area	Machine		Continue	Ready	\$1	Active channel
Selected operating mode	1303 SERCOS state class 1. Manufacturer-specific error Z-axis					Contin.
Current diagnosis	WCS	Command	End Position	Dist. to Go	Unit	Selection of machine functions
	X	-5.088	-5.088	0.000	mm	
	Y	-0.839	-0.839	0.000	mm	
	Z	13.709	13.709	0.000	mm	
Program status displayed	/ct/HSC-TEST.npg		ActTool	0	Edge	1
	G46 G08 JKC(1)		Program	Actual		
	T1 M6		F	4# mm	0.00	0.00
	G54 G62 G00 G90 X147.0 Y69.0 Z0.0 S100C				80%	
	G01 X-101.0 Y69.0 F1911.0 RND(5)					
	X-101.0 Y-1.0					
	X99.0 Y-1.0					
	Automatic					
	SelfProg	Edit	BigPos	ViewOffs	ZeroOffs	Variables
				Monitor	Next	Functions of operating area

High speed free form surface milling

High speed milling is always about finding the right mixture of machining speed, surface quality and part accuracy. IndraMotion MTXmicro supports the user selecting the required machining mode with the easy to use cycle G591. Active Contour Smoothing (ACS) eliminates facet artifacts created by the CAD/CAM process chain to improve the work piece' visual appearance. This ensures a perfect part surface in the shortest possible time.

Features

- ▶ G591 high speed milling cycle
- ▶ Automatic parameter optimization
- ▶ Supports machining modes from
 - pre-roughing to
 - extra-fine finishing
- ▶ Active Contour Smoothing for perfect part surface

- ▶ Better results with G591 and Active Contour Smoothing
- ▼ Results without (left) and with ACS (right)

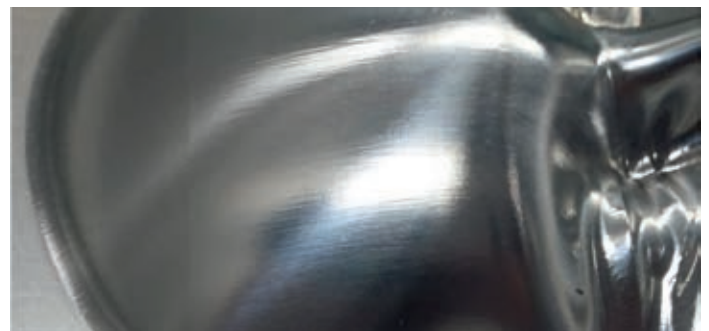
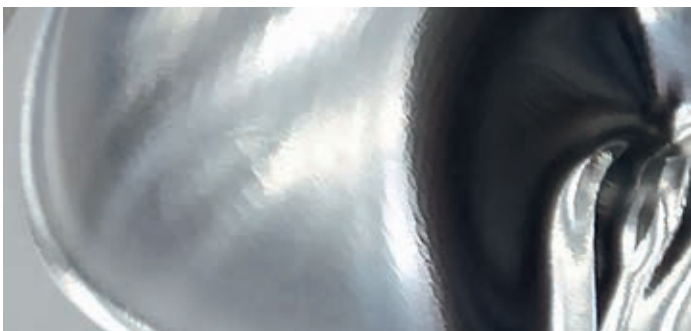
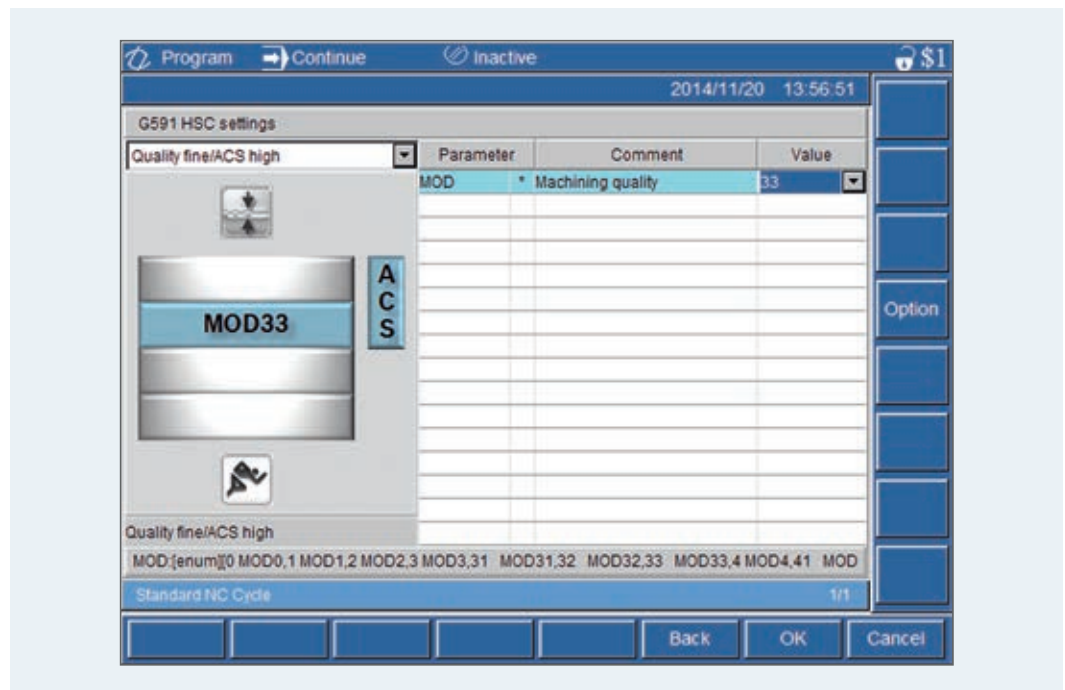

Cycles – parameterize instead of program

IndraMotion MTX micro features numerous technology cycles for standard machining processes. The comprehensive library also covers combined turning/milling machining. Intuitive user guidance makes it easier to select a cycle and enter parameters. Dialogs provide information in text and graphical form. Everything remains straightforward thanks to practical pre-assignment of parameters. Even complex machining tasks can be carried out very quickly. This, in turn, improves efficiency and helps to avoid errors.

Contour cycles are used to easily program and efficiently machine turning and milling workpieces. Workpiece contours are described with DIN G-Code and the dimensions for lines, radii and chamfers copied into the program directly from the workpiece drawing. The contour cycles calculate automatic cut segmentation during machining and ensure efficient tool guidance. Threads, grooves, undercuts and pockets are then simply added via parameter configured technology cycles.

Cycle examples

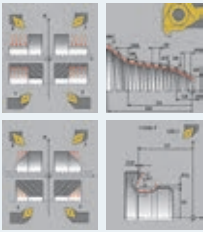

▲ Turning

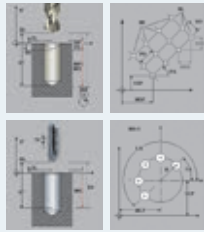

▲ Drilling

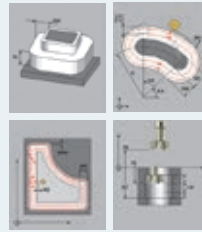

▲ Milling

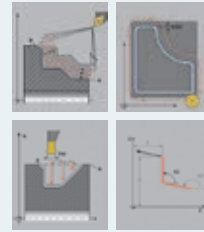

▲ Contouring

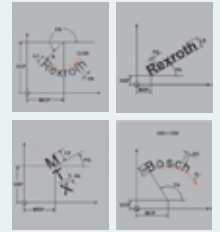

▲ Engraving

Cycle input dialog

Program → Continue Prepare

G160 Longitudinal turning

2-Machining right-internally

Parameter	Comment	Value
SR	* Starting point diameter	0
SA	* Starting point longitudinal direc	3
ER	* End point diameter	12
EA	* End point longitudinal direction	-30
CD	* Depth of cut	2

Graphical assistance for every parameter

Search

Option

Brief description of parameter

View optional parameters for experts

Plausibility protocols of parameters entered

2-Machining right-internally

EA[real]End point longitudinal direction

Standard Cycle L4/5

Back Submit Cancel

Graphic contour editor

The IndraMotion MTX graphic contour editor makes programming of simple to complex contour definitions easy. The software guides the user step by step with simple graphic elements during the input. Every element is defined with an intuitive parameter editor. All options and transitions to the next element are shown at a glance. Parameter changes will instantly shown by the contour graph. The contour is saved in the NC program as DIN G-Code.

Features

- ▶ Elements: horizontal & vertical line, angular line and CW & CCW arc
- ▶ Unlimited number of graphic elements
- ▶ Contour definition in sub-routine or directly in the NC program
- ▶ Multiple contour definitions in the same NC program
- ▶ Plausibility check during contour input
- ▶ Contour is written as DIN G-code in the CNC program
- ▶ Contour can be edited afterwards in the graphic editor or manually

Contour input dialog

The screenshot displays the 'Contour Editor' window. The main area shows a 2D contour graph with axes X(D) and Z. The graph shows a series of connected line segments forming a stepped profile. A green circle on the left side of the graph indicates a 'Plausibility check result'. To the right of the graph is a 'Parameter' editor with fields for 'Z' (value: -101.000), 'X(D)', and 'A'. Below the parameter editor is a 'Transition' selection area with four options (1, 2, 3, 4) and their corresponding diagrams. A vertical toolbar on the right side contains icons for zooming and selecting elements. At the bottom, there is a 'Contour Editor' toolbar with icons for line, arc, and other elements, along with 'Edit', 'Save', and 'Exit' buttons.

Parameter editor for each graphics element

Transition elements selection

Zoom an move contour graph

Graphics elements selection

Plausibility check result

Efficient CNC programming

NC functions with syntax according to DIN 66025

The conversational NC programming – movement sequences and their boundary conditions (geometry, kinematics, dynamics, corrections, etc.) are described using DIN programming. Standard programming is a language only for writing commands that control movements at the machine and specific machine functions.

The NC functions with high-level language syntax

These NC functions enhance G-code programming according to DIN 66025 to include additional performance functions for effective NC programming. The syntax also makes it easier to understand the NC program. Example: scale (long form) or SCL (short form) for enlarging or reducing a programmed contour.

NC editor

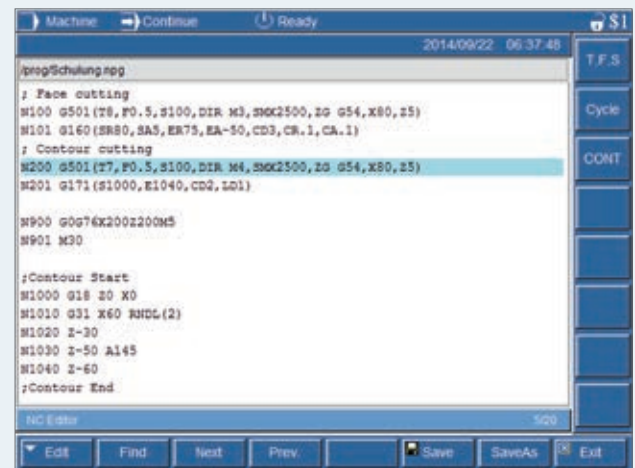

```

Machine → Continue Ready 2014/09/22 06:37:48
/propSchulung.npp
; Face cutting
M100 G501 (T8, F0.5, S100, DIR M3, SMK2500, Z0 G54, X80, Z5)
M101 G160 (SR80, SAS, ER75, EA-50, CD3, CR.1, CA.1)
; Contour cutting
M200 G501 (T7, F0.5, S100, DIR M4, SMK2500, Z0 G54, X80, Z5)
M201 G171 (S1000, E1040, CD2, LD1)

M900 G0076X200Z200M5
M901 M30

;Contour Start
M1000 G18 Z0 X0
M1010 G31 X60 RMDL(2)
M1020 Z-30
M1030 Z-50 A145
M1040 Z-60
;Contour End
  
```

The CPL programming

(Customer Programming Language)

CPL is based upon the BASIC high-level language standard and can therefore be easily learned. CPL can be used for variable programming, mathematical operations, control structures such as REPEAT, WHILE, FOR, IF, CASE, GOTO and access to system states.

Using CPL leads to:

- ▶ Shorter NC programs for repeat procedures and similar program segments
- ▶ Condition-based program variants
- ▶ Universally applicable subprograms

User cycles

DIN and CPL programming can be used to create separate cycles. Simple configuration allows them to be seamlessly integrated into the system next to the technology cycles.

Cycle selection



User defined screens

Intuitive and quick operation of machine tools is getting more and more important. The IndraMotion MTX micro user defined screens enable the machine tool builder to differentiate by adding easy to use and machine operation focused content. User guidance with graphic status elements and pictures help the operator to master the machine operation quickly.

Features

- ▶ Read access to standard values like axis position and spindle speed
- ▶ Read and write access to variables and parameters in PLC, CNC and Drive
- ▶ Unlimited number of screens
- ▶ User defined function and machine key panels
- ▶ Recipe management with automatic program selection and parameterization
- ▶ Create and edit user screens directly inside the HMI
- ▶ Encryption of user screen files

Sample I

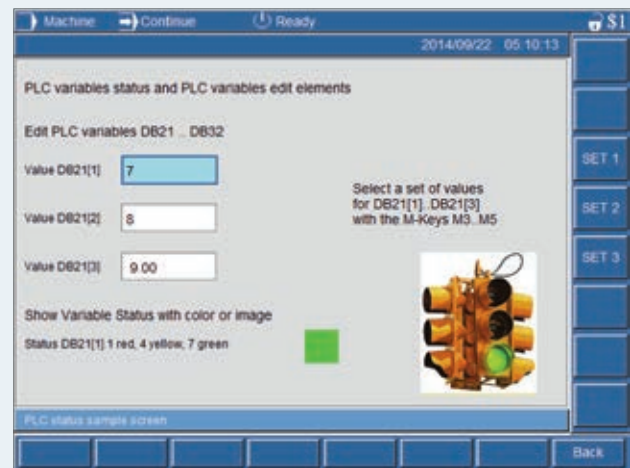

Sample II

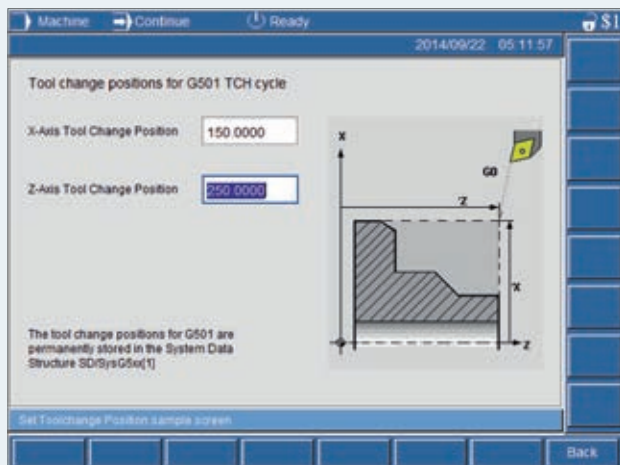

Sample III

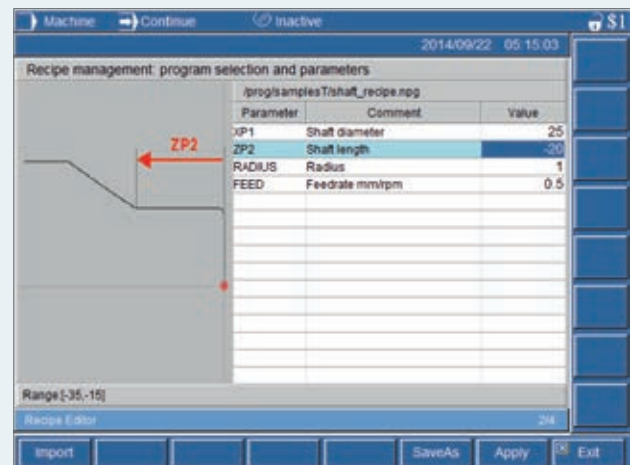

Flexible setup functions

Tool management

The tool management facility is easy to use and can be adapted to the machine:

- ▶ Up to 999 tools, 16 cutting edges per tool
- ▶ Geometry and wear corrections
- ▶ Tool life management
- ▶ Radius correction, cutting edge correction
- ▶ Angle head tools
- ▶ Fixed-place coding/variable coding
- ▶ Alternate tools

Set workpiece and tool zero points

Intuitive dialogs for setting the zero points for workpieces and tools assist the operator during routine work. This simplifies the process of setting up the machine and reduces the time required for this – minimizing mistakes.

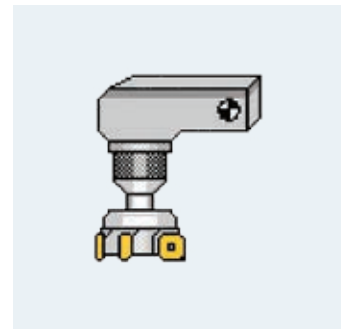
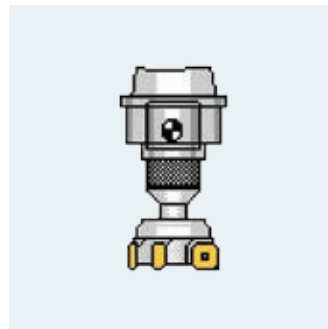
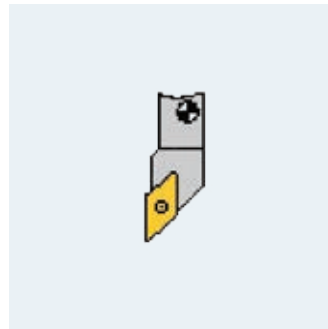

Toolset

Machine Manual Jog Inactive 2014/09/02 13:53:56 S1

WCS Command

X mm -15.937

Y mm 0.000

Z mm 0.000

Zero Offset Table (database/Z01.zot mm)

Offsets	X	Y	Z
G54.1	0.000	0.000	50.000
G55.1	0.000	0.000	0.000
G56.1	0.000	0.000	0.000
G57.1	0.000	0.000	0.000
G58.1	0.000	0.000	0.000
G59.1	0.000	0.000	0.000

Set zero offsets

Set B Pre Step Cancel

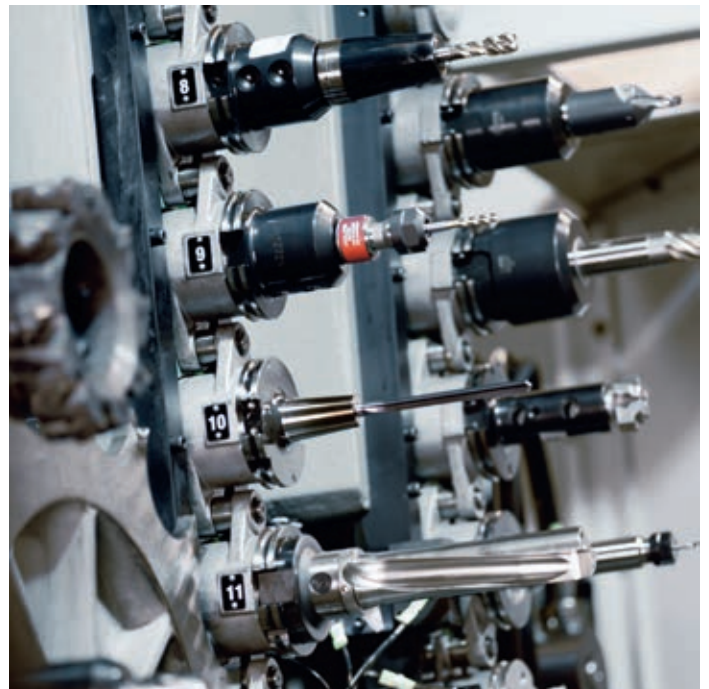

IndraMotion MTX micro Trainer – learn it easily, master it quickly

CNC operation and programming of IndraMotion MTX micro



With the software IndraMotion MTX micro trainer you simulate the CNC control system IndraMotion MTX micro on a PC. With the exact simulation of the operator panel and of the user interface you learn easily how to operate and create CNC programs for the IndraMotion MTX micro and you can master the tasks in a short time. The CNC programming of the IndraMotion MTX micro is identical to the CNC control variants IndraMotion MTX standard, MTX performance and MTX advanced.

Benefits

- ▶ Easy learning of the operation and programming of the IndraMotion MTX micro CNC controller
- ▶ Testing of CNC programs in a realistic environment without the machine
- ▶ Sample programs and documentation included
- ▶ CNC programming is consistent with all IndraMotion MTX CNC controls.
- ▶ Cost free download from Internet

Impressive performance

Maximum precision

- ▶ High-resolution processing of command and actual positions ensures precision machining down to the nano-meter.
- ▶ The absolute encoders for the servo motors, with a resolution of $2^{21} = 2\,097\,152$ /revolution, provide for high control quality.
- ▶ Multiturn absolute encoders eliminate the need to reference the servo axes after the machines have been activated, even when long traversing ranges are involved.
- ▶ Special drive based compensations for mechanical non-linearities.
- ▶ All parameters required for operation are stored in the encoder data memory in a fail-safe manner.



Dynamic movements for short machining times

Intelligent drive technology meets the demanding requirements for control quality and dynamics of the servo axes.

- ▶ All control functions are implemented close to the drive to achieve fast clock rates of up to $125\ \mu\text{s}$.
- ▶ The default parameter settings of the system typically eliminates the need for further optimization.
- ▶ Numerous options for making filter settings (e.g. electric current target value filter, axis-specific jerk limitation) meet the requirements for particularly dynamic motion sequences; autotuning, an oscilloscope function and integrated testing functions minimize commissioning times.

▲ Precision machining down to the nanometer with IndraMotion MTX micro

▼ Filter settings (e.g. electric current target value filter) enable very dynamic axis movements with ultra-high machining accuracy

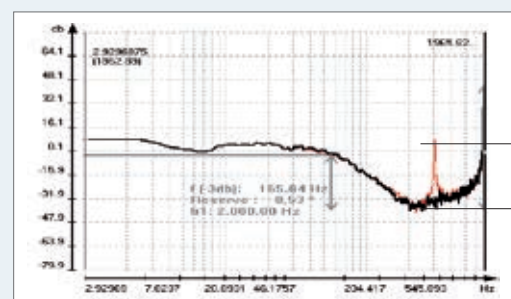

without filter

with filter

Direct communication

Program processing over the network

- ▶ Easy integration of IndraMotion MTX micro in existing network infrastructure via Ethernet and TCP/IP
- ▶ Almost unlimited storage space for CNC programs and data
- ▶ Slim transfer protocol ensures fast data transmission
- ▶ Seamless integration of external CNC data in the IndraMotion MTX micro file system via network drives

Program processing over the external storage media

- ▶ A USB port on the front of the control panel can be used to connect external storage media such as a USB memory stick
- ▶ Integration of storage media in the file system of the controller enables direct selection of CNC programs (copying not necessary)

Remote maintenance and diagnostics

TCP/IP communication allows a connection to be made to an office PC and CNC control system. This, in turn, makes it possible to carry out diagnostics from a control station or even perform remote maintenance over the Internet.

- ▼ **Integration of IndraMotion MTX micro in existing network**
 - Remote maintenance over the Internet
 - Program execution over the network
 - Backups or program processing using a USB port

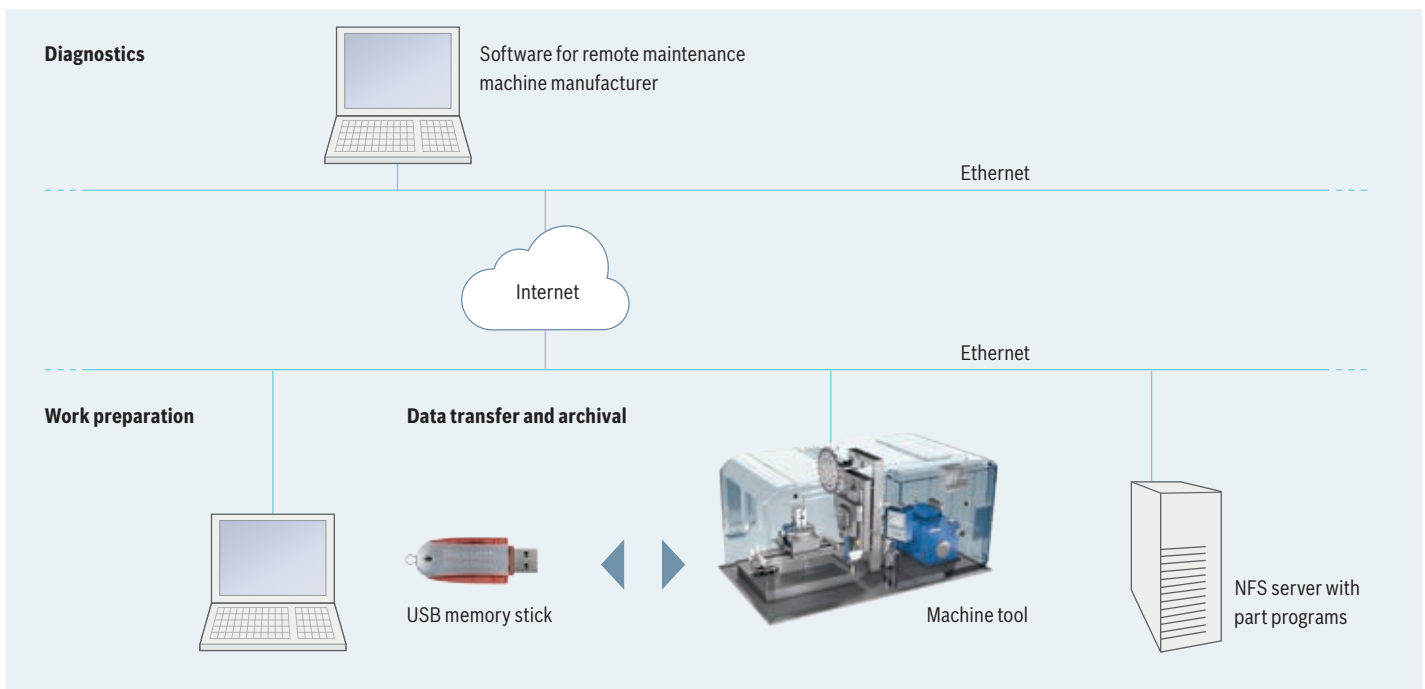

Easy installation and commissioning

IndraMotion MTX micro from Rexroth raises the bar when it comes to easy installation and commissioning of a high-performance CNC system. Basic projects are provided for applications involving a typical CNC machine. A turning machine, milling machine or turning center can thus be parameterized in no time by loading the software. You can then concentrate on what matters most: the machine itself.

The high level of system integration also offers decisive advantages with respect to assembly and maintenance:

- ▶ Minimum number of modules
- ▶ Easy wiring
- ▶ Screwless terminals
- ▶ Ultrahigh availability
- ▶ Maintenance-free hardware

Easy Setup Documentation

The compact setup documentation is easy to understand but also comprehensive, since all relevant information is provided for you to quickly commission the CNC system.

List of contents

- ▶ Choosing and connecting hardware
- ▶ Basic software installation
- ▶ Basic project and general settings
- ▶ PLC commissioning
- ▶ Commissioning and optimization of the drives
- ▶ IndraMotion MTX micro operating software
- ▶ Connection diagrams
- ▶ Overview of parameters
- ▶ Standard I/O assignment

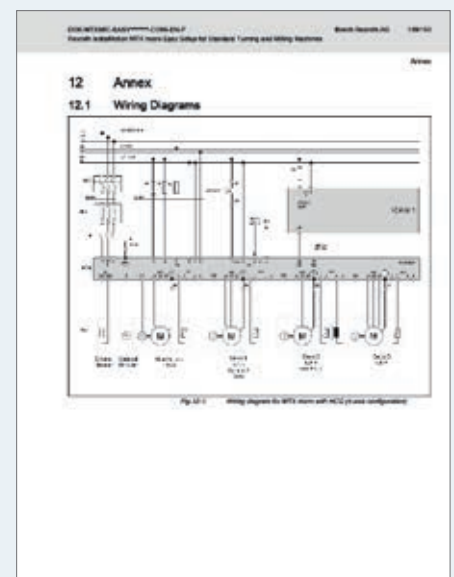

Comprehensive service portfolio

We offer you not only a complete range of drive and control solutions, but also an in-depth consultancy expertise and a best-in-class service portfolio: from conceptual development above commissioning to modernization – for an economical lifecycle of the machine.



Industry-focused engineering and applications support

Our experienced team of industry experts provides advice and support to assist you during conceptual development and design of your solution:

- ▶ Selection of specific automation components (hardware and software) for your application
- ▶ Detailed description of control and drive components, interfaces and data management
- ▶ Development of sample applications
- ▶ Active involvement in initial applications at your site
- ▶ Support during integration of Ethernet-based sercos real time communications
- ▶ Individual support for the systematic and compliant issue of safety strategies

Software and hardware engineering

Rexroth provides expert advice and support to assist you during development of your production systems and networks. IEC-compliant PLC function modules and NC cycles for nearly all industry sectors are available in our software library.

Commissioning

Our technical support experts are right at your side whenever you need fast, professional assistance during the commissioning phase. Each of our teams are made up of service engineers who specialize in a particular industry.

Service

Our service team supports you throughout the planning, installation, commissioning, operation and extended life phases:

- ▶ Technical support/helpdesk
- ▶ Field service
- ▶ Repair service
- ▶ Spares service
- ▶ Retrofit and modernization
- ▶ Training



Example I: Simple turning machine with 2 axes, 1 spindle

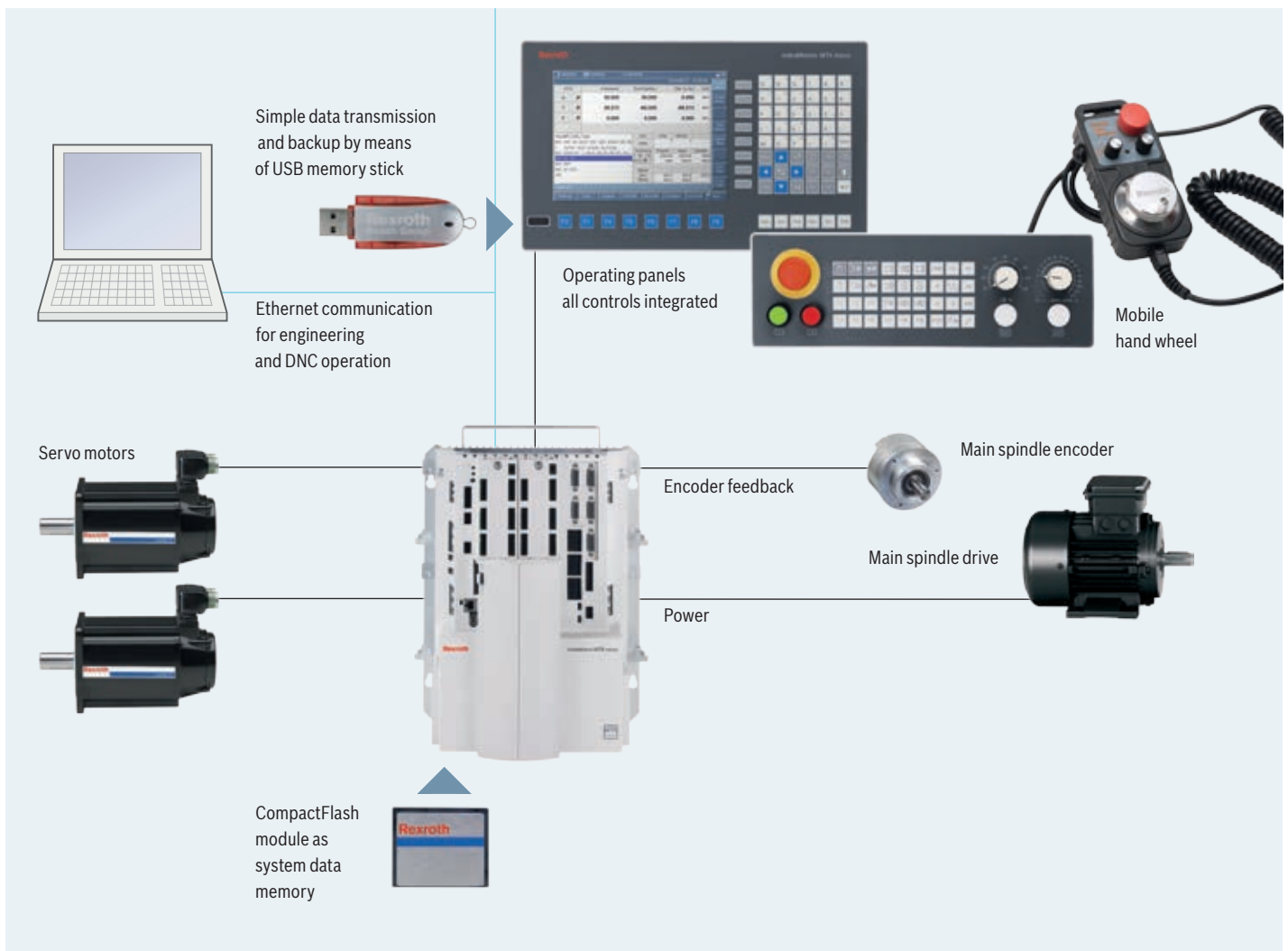

Multi-axis drive controller

- ▶ Integrated control with CNC kernel and IEC 61131-3 compliant PLC
- ▶ High-end servo functions
- ▶ HMI function
- ▶ Modular expandable I/O assembly
- ▶ Simple direct connection for 24 VDC I/O signals
- ▶ No adaptation transformer required
- ▶ Pluggable cable for power and encoder feedback
- ▶ Integrated frequency converter to actuate standard asynchronous motors of up to 11 kW
- ▶ Connection to external main spindle encoder

Example II: Milling machine with 5 axes, 1 spindle

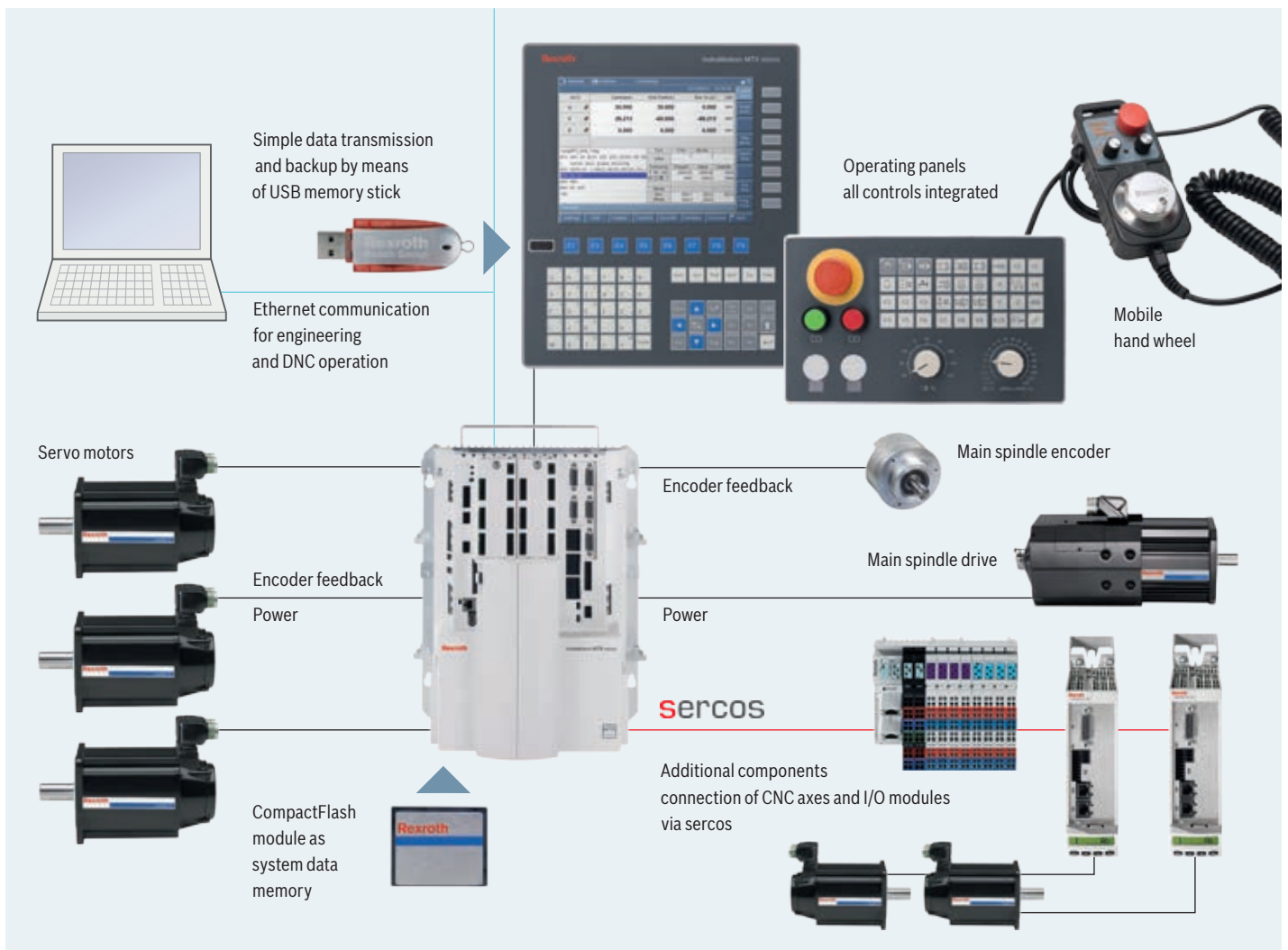

Multi-axis drive controller

- ▶ Integrated control with CNC kernel and IEC 61131-3 compliant PLC
- ▶ High-end servo functions
- ▶ HMI function
- ▶ Modular expandable I/O assembly
- ▶ Simple direct connection for 24 VDC I/O signals
- ▶ No adaptation transformer required
- ▶ Pluggable cable for power and encoder feedback
- ▶ Actuation of high-performance spindle motors up to 11 kW
- ▶ Connection to external main spindle encoder

IndraDyn A

MAD air-cooled asynchronous servo motors

With their impressive power density, the MAD range of motors is predestined for servo and main spindle applications in machine tools.

High-resolution single-turn or multi-turn encoder systems and outstanding true running quality guarantee highest handling precision. In addition to the optional keyway and holding brake, these motors can also be supplied with a special bearing assembly for high-speed applications or for applications with increased radial load. The motor protection category IP65 even includes the fan motor, making it suitable for harsh industrial use.



The simple-step-by-step guide

to ordering your MSK servo motor:

MAD **100C-0100-SA-S2-AH0-05-N1**

Motor

- ▶ Size (e.g. 100)
- ▶ Overall length (e.g. C)
- ▶ Winding (e.g. 0100)

Cooling system

- SA** – Axial-flow fan
- SL** – Fan cowl

Encoder

- S2** – Single-turn encoder (EnDat), 2,048 signal periods
- M2** – Multi-turn encoder (EnDat), 2,048 signal periods with 4,096 revolutions absolute
- S6*** – Single-turn encoder (EnDat), 2,048 signal periods for potentially explosive atmospheres
- M6*** – Multi-turn encoder (EnDat), 2,048 signal periods with 4,096 revolutions absolute for potentially explosive atmospheres
- C0** – Incremental encoder, 2,048 increments

Line terminal

Plug**

- A** – On the A side
- B** – On the B side
- L** – Left
- R** – Right

Terminal box turntable

- E** – On the A side
- H** – On the B side
- G** – Left
- D** – Right

Vibration severity grade

- 1** – A
- 3**** – B
- 4**** – C

Bearing assembly

- N** – Standard
- A**** – Fixed bearing A side
- H**** – High speed
- V**** – Heavy duty

Construction

- 05** – Flange-mounted
- 35** – Flange mounted or foot-mounted

Holding brake

- 0** – Without holding brake
- 1** – With electr. released holding brake
- 3**** – With electr. released holding brake, heavy-duty
- 5**** – With electr. clamped holding brake

Shaft version e.g.

- Plain shaft
- H** – Without seal ring
- G** – With seal ring (IP65)
- F** – With labyrinth seal
- Keyway
- Q** – Without seal ring
- P** – With seal ring (IP65)
- R** – With labyrinth seal

* Equipment group II 2G, type of protection EEx p d IIB T3 only in combination with fan cowl cooling option SL
 ** Only for certain sizes

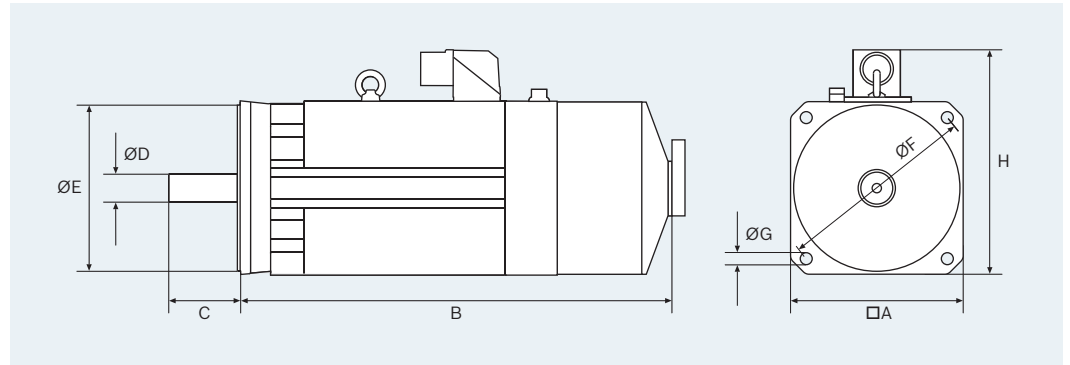
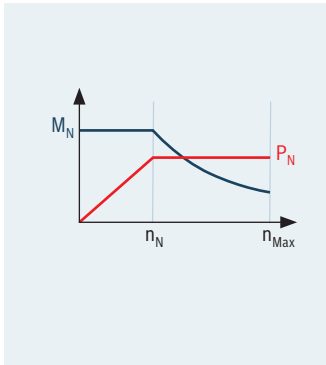

Technical data

Type		Rated power PN [kW]	Rated speed nN [min ⁻¹]	Maximum speed nMax [min ⁻¹]	Rated torque Mn [Nm]	Maximum torque MMax [Nm]	Rated current IN [A]	Maximum current I _{max} (eff) [A]
MAD100	B-0100	3,2	1000	6000	31	74,7	8,9	18,0
	B-0150	4,7	1500	9000	30	68,0	12,9	23,5
	B-0200	5,9	2000	11000	28	66,2	14,6	28,9
	B-0250	6,5	2500	11000	25	61,5	16,2	28,3
	C-0050	2,7	500	3000	51	112,3	8,2	15,9
	C-0100	5,2	1000	6000	50	118,8	13,2	25,4
	C-0150	7,5	1500	9000	48	110,4	19,7	39,0
	C-0200	9,4	2000	11000	45	105,5	25,7	47,3
	C-0250	10,5	2500	11000	40	91,0	27,8	44,9
	D-0050	3,7	500	3000	70	153,6	10,1	19,1
	D-0100	6,7	1000	6000	64	146,5	19,3	34,3
	D-0150	9,3	1500	9000	59	140,8	25,6	47,6
	D-0200	11,3	2000	11000	54	129,8	27,2	52,7
MAD130	B-0050	5,0	500	3000	95	208,8	12,8	25,4
	B-0100	10,5	1000	6000	100	230,0	26,9	53,7
	B-0150	13,3	1500	9000	85	155,0	34,9	71,0
	C-0050	7,3	500	3000	140	307,9	19,7	35,3
	D-0050	9,4	500	3000	180	395,6	24,2	47,0

Dimensions

Type		JR [kgm ²]	A [mm]	B [mm]	C [mm]	ØD [mm]	ØE [mm]	ØF [mm]	ØG [mm]	H [mm]
MAD100	B-0100	0,019	192	533	60	32	130	215	14	277 (264)
	B-0150	0,019	192	533	60	32	130	215	14	277 (264)
	B-0200	0,019	192	533	60	32	130	215	14	277 (264)
	B-0250	0,019	192	533	60	32	130	215	14	277 (264)
	C-0050	0,028	192	608	60	32	130	215	14	277 (264)
	C-0100	0,028	192	608	60	32	130	215	14	277 (264)
	C-0150	0,028	192	608	60	32	130	215	14	277 (264)
	C-0200	0,028	192	608	60	32	130	215	14	277 (264)
	C-0250	0,028	192	608	60	32	130	215	14	277 (264)
	D-0050	0,039	192	683	60	32	130	215	14	277 (264)
	D-0100	0,039	192	683	60	32	130	215	14	277 (264)
	D-0150	0,039	192	683	60	32	130	215	14	277 (264)
	D-0200	0,039	192	683	60	32	130	215	14	277 (264)
MAD130	B-0050	0,084	260	641	110	42	250	300	18	345 (340)
	B-0100	0,084	260	641	110	42	250	300	18	345 (340)
	B-0150	0,084	260	570	110	42	250	300	18	345 (340)
	C-0050	0,108	260	711	110	42	250	300	18	345 (340)
	D-0050	0,164	260	841	110	42	250	300	18	345 (340)

IndraDyn S

MSK synchronous servo motors

The particularly outstanding features of the MSK range of motors are its wide power spectrum and narrow size increments. The high torque density of these synchronous servo motors allows a particularly compact design with maximum torques of up to 28 Nm. Depending on the level of precision required, we can supply the motors with encoder systems with a low, medium, or high resolution. All encoder versions are available in a single-turn and multi-turn configuration.

A number of further options, such as the shaft keyway, holding brake, reduced runout and the high protection category IP65 mean that they can be used in virtually any application.



The simple-step-by-step guide to ordering your MSK servo motor:

MSK **060C-0600-NN-S1-UG0-NN NN**

Motor

- ▶ Overall size (e.g. 60)
- ▶ Overall length (e.g. C)
- ▶ Winding (e.g. 0600)

Cooling system

NN – Natural convection
Surface cooling or liquid cooling optional for certain sizes

Encoder

- S1** – Single-turn encoder (Hiperface®), 128 signal periods
- M1** – Multi-turn encoder (Hiperface®), 128 signal periods with 4,096 revolutions absolute
- S2*** – Single-turn encoder (EnDat), 2,048 signal periods
- M2*** – Multi-turn encoder (EnDat), 2,048 signal periods
- S3** – Single-turn encoder (Hiperface®), 16 signal periods
- M3** – Multi-turn encoder (Hiperface®), 16 signal periods with 4,096 revolutions absolute

Shaft

- G** – Plain shaft with shaft sealing ring
- P** – Keyway conforming to DIN 6885-1 and shaft sealing ring

Other versions

- N** – Standard
- S1**** – Ex-protected version conforming to Equipment Group II, Category 3, G and D

Shaft runout

- N** – Standard, in conjunction with S1/M1 or S3/M3 encoder only
- R** – Reduced, linear movement conforming to DIN 42955, in conjunction with S2 or M2 encoder only

Holding brake

- 0** – Without holding brake
- 1** – With electr. released holding brake
- 2**** – With heavy-duty holding brake
- 3**** – With extra-heavy-duty holding brake

* From size MSK040
** Only for certain sizes

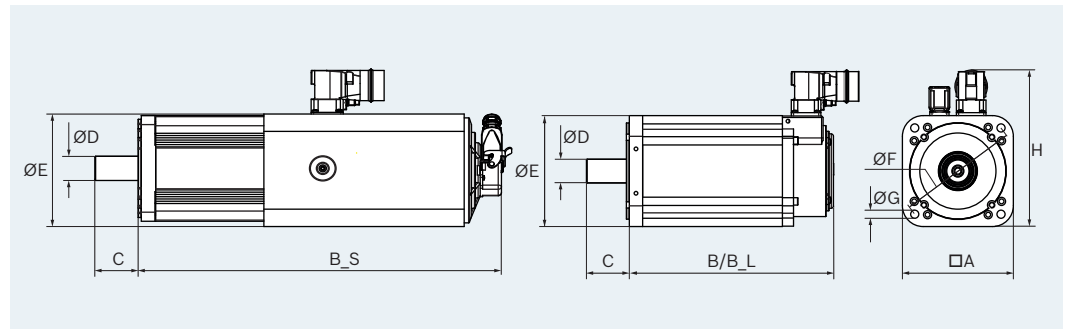
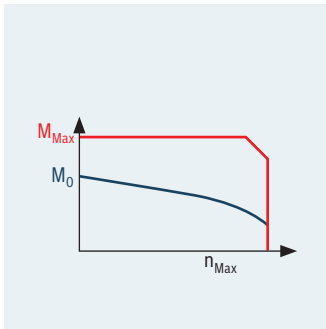

Technical data						
		Maximum speed	Continuous torque at standstill	Maximum torque	Rated current	Maximum current
Type		IMax [rpm]	M0 [Nm]	MMax [Nm]	IN [A]	IMax [A]
MSK061	B-0300	4200	3,5	14	1,9	8,6
	C-0300	4200	8,0	32	4,3	19,4
MSK075	C-0300	5000	12,0	44	8,4	37,8
	D-0300	4800	17,0	66	11,7	52,7
MSK100	B-0200	4100	28,0	102	14,7	66,2

Dimensions										
Type		JR [kgm ²]	A [mm]	B [mm]	C [mm]	ØD [mm]	ØE [mm]	ØF [mm]	ØG [mm]	H [mm]
MSK061	B-0300	0,000	116	223	40	19	95	130	9	156
	C-0300	0,001	116	264	40	19	95	130	9	156
MSK075	C-0300	0,004	140	307	58	32	130	165	11	202
	D-0300	0,005	140	347	58	32	130	165	11	202
MSK100	B-0200	0,019	192	368	60	32	130	215	14	262

Technical data

1	Technology		
1.1	Turning		●
1.2	Drilling		●
1.3	Milling		●
2	Axis control		
2.1	Number of axes (3 axes variant/4 axes variant)	3/4	●
2.2	Maximum axes	12	○
2.3	Max. number of spindles thereof	4	●
2.4	Number of independent channels	2	●
2.5	Max. number of interpolating axes per channel	5	○
2.6	Spindle/C axis switching		●
2.7	Channel-crossing axis transfer		●
2.8	Software limit		●
2.9	Additional spindle encoders	1	●
3	Interpolation functions		
3.1	Linear interpolation with/without exact stop		●
3.2	Circular interpolation with radius and center-point programming, helical interpolation, tangential entry		●
3.3	Tapping with/without compensating chuck		●
3.4	Thread cutting		●
3.5	NC block preview, look-ahead with jerk limitation		●
3.6	Jogging with active transformation		●
3.7	Nanometer resolution		●
4	Feed function		
4.1	Feed with mm/min or inch/min		●
4.2	Time programming		●
4.3	Feed rate per revolution		●
4.4	Constant surface speed		●
4.5	Feed on positive stop		●
4.6	Torque reduction		●
5	Displacements and corrections		
5.1	Mirroring, scaling, rotating		●
5.2	Zero-point offset		●
5.3	Placements (FRAMES) – coordinate displacement and rotation in the space		●
5.4	2D compensation		●
6	Tool management		
6.1	Integrated tool management with database for up to 999 tools		●
6.2	Tool data entry and organization of tool lists		●
6.3	Tool corrections (length, radius, edge length)		●
6.4	Standstill time management		●
6.5	Access to tool data from PLC and CNC		●

7	CNC programming				
7.1	Parts program development		DIN ISO 66025/RS274 D	●	
7.2	High level language CPL (Customer Programming Language)			●	
7.3	CNC memory		64 MB	●	
7.4	Static memory		4 MB	●	
7.5	Max. parts program size		8 MB	●	
7.6	Memory		1 GB	●	
7.7	Technology cycles for turning, drilling, milling			●	
7.8	Cycles for contour machining for turning and milling			●	
8	Functions				
8.1	Dwell time in seconds			●	
8.2	Acceleration programming, loop gain programming			●	
8.3	Homing through the NC program			●	
8.4	Absolute dimension, relative dimension			●	
8.5	Switching between inch/mm			●	
8.6	Probe, static/on-the-fly measurement			●	
8.7	Roundings and chamfers			●	
8.8	Corner rounding with splines			●	
8.9	NC set command from PLC			●	
8.10	NC programm restart/block search			●	
8.11	Dry Run			●	
8.12	Retracting from and returning to the contour			●	
9	PLC functions				
9.1	Integrated PLC: IndraLogic with programming languages IEC 61131-3 (IL, LD, FBD, ST, SFC, CFC)			●	
9.2	PLC program memory		2 MB	●	
9.3	Number of I/O		32 I/16 O	●	
9.4	Max. number of I/O		96 I/48 O	○	
9.5	Optional, modular I/O with sercos		8 kB	○	
10	Diagnosis and commissioning tools				
10.1	Automatic system diagnoses			●	
10.2	Error messages in plain text (standard languages: German, English Chinese)			●	
10.3	Installation from additional languages			○	
10.4	Integrated drive setup tools			●	
10.5	Drive oscilloscope			○	
10.6	Integrated PLC setup tools			○	
10.7	Engineering tool IndraWorks			○	
11	Drive system				
11.1	Mains voltage three phases at the networks TT, TN-C, TN-S, IT		200 – 500 V ±10 %		
11.2	Mains frequency		50 – 60 Hz ±2 Hz		
11.3	Mains connection capacity with power choke		30 kVA		
11.4	Rated current		44 A		
12	Controlled servo motors	Axis 1	Axis 2¹⁾	Axis 3	Axis 4
12.1	Standstill torque M_0 [Nm]	28	17	12	12
12.2	Rated current I_n [A]	35	20	14	14
12.3	Maximum current I_{max}	55	50	31	31
13	Spindles				
13.1	Controlled main spindle drive (Closed Loop)	●	●	–	–
13.2	Standard asynchronous spindle motor (Open Loop)	●	●	–	–
13.3	Rated capacity P_n [kW]	11	5	–	–
13.4	Connection to external spindle encoder	●	●	–	–

Bosch Rexroth AG

Bgm.-Dr.-Nebel-Str. 2
97816 Lohr, Germany
www.boschrexroth.com

Find your local contact person here:

www.boschrexroth.com/contact

Further information:

www.boschrexroth.com/mtx

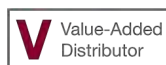

248-373-1600 • morrell-group.com • orders@morrellinc.com

MI • IN • IL • OH • ON, CAN

