

Linear modules MKK, MKR, MLR

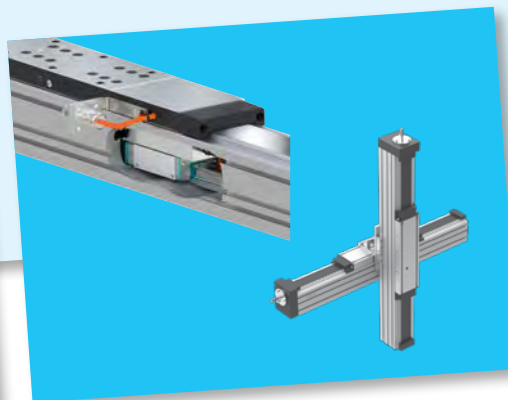
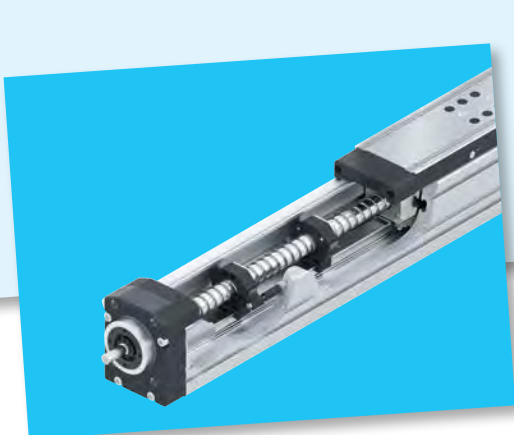
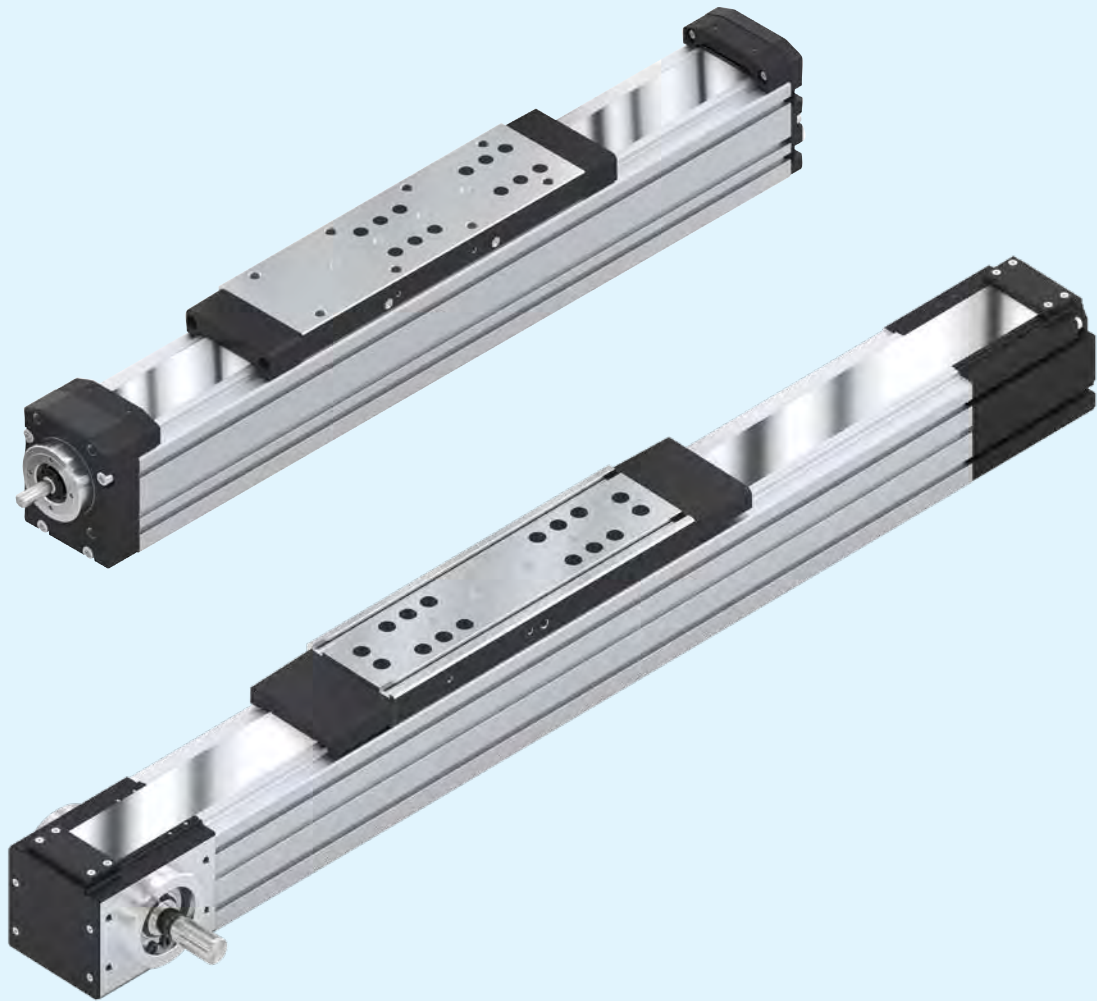

Overview

Rexroth linear modules

Identification system for short product names

Example		M	K	K	- 110 -	NN	- 3
System	= Linear module						
Guideway	= Ball rail system (BSHP) (K) = Cam roller guide (L)						
Drive	= Ball screw drive = Toothedbelt drive (KR)						
Size	= 040 / 065 / 080 / 110 / 140 / 145 / 165						
Version	= NN-Normal version						
Generation	= Product generation 2/3						

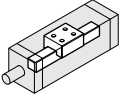
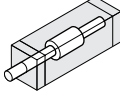
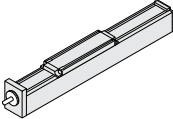
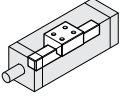
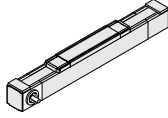
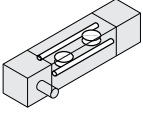
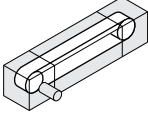
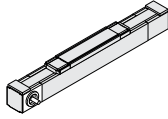
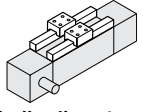
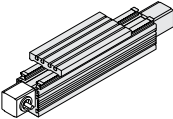
Type	Guideway	Drive	Linear module
MKK	 Ball rail system (K)	 Ball screw assembly (K)	
MKR	 Ball rail system (K)		
MLR	 Cam roller guide (L)	 Belt drive (R)	
MKR-145	 Two ball rail systems (K)		

Changes/additions at a glance/General notes

Catalog layout

- MKK / MKR size 040 in product generation NN-3
- MKK / MKR new size 140
- MKR size 145 in product generation NN-3
- MLR size -080 / -110 in product generation NN-3
- Linear modules Food & Packaging MKR 080 (Product discontinuation, no longer in catalog)

General notes:

- Some figures are schematic and can be in different scales.
Exact contours and dimensions can be found in the CAD model.
CAD configurator available on the Internet at www.boschrexroth.com "Product configurators".

Printed catalogs from approx. end of March 2020.

Product generations

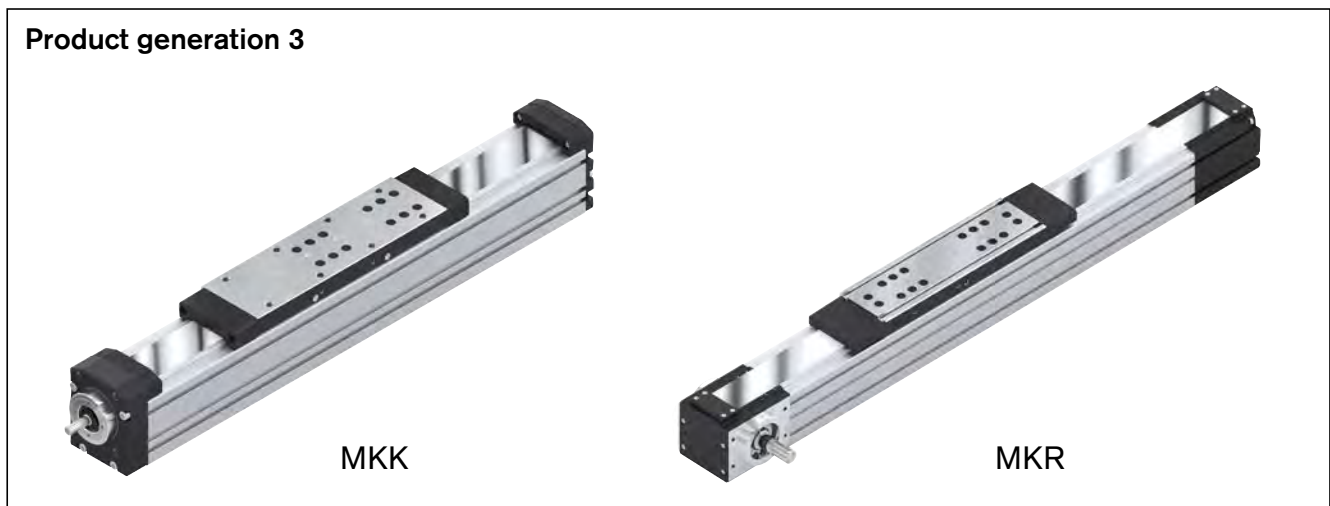
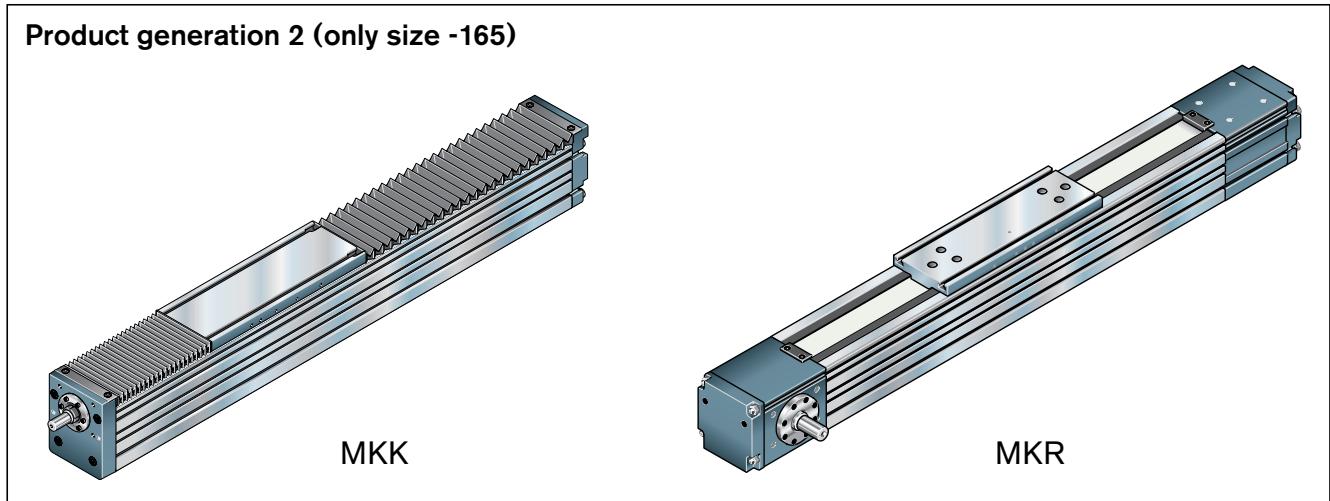

Linear module	Size	Product generation 2	Product generation 3 (new)
MKK - / MKR - NN	-040	Replaced by generation 3	MKx-040-NN-3
	-065	Replaced by generation 3	MKx-065-NN-3
	-080	Replaced by generation 3	MKx-080-NN-3
	-110	Replaced by generation 3	MKx-110-NN-3
	-140	-	MKx-140-NN-3
	-165	MKx-165-NN-2	-
	-145 (MKR only)	Replaced by generation 3	MKR-145-NN-3
MLR - NN	-080	Replaced by generation 3	MLR-080-NN-3
	-110	Replaced by generation 3	MLR-110-NN-3

MKx: x = K for ball screw drive, x = R for belt drive

Contents

General product description MKK/MKR/MLR/OBB	6	Attachments and accessories	106
Linear modules delivery form	10	Fastener	106
Linear modules MKK	12	Mounting and fastening elements	108
Product description MKK-xxx-NN-3	12	Connecting shafts	110
Product description MKK-165-NN-2	15	Dimensional drawings	111
Structural design	16	Nozzle pipe	112
Technical data	18	Frequency meter	112
Configuration and ordering	30	Connection technology for linear motion systems	113
MKK-040-NN-3	30	Product description	113
MKK-065-NN-3	32	Connection options	113
MKK-080-NN-3	34	Motors	114
MKK-110-NN-3	36	Motor attachment kits	
MKK-140-NN-3	38	according to customer specification	114
MKK-165-NN-2	40	IndraDyn S - MSM servo motors	116
Dimensional drawings		IndraDyn S - MS2N servo motors	118
MKK-040/-065/-080/-110/-140/-NN-3	42	Switching system MKK, MKR, MLR	122
MKK-165-NN-2	48	Overview of switching system	122
Linear modules MKR	50	Switch mounting arrangement MKK/MKR-040-NN-3	122
Product description MKR-xxx-NN-3	50	Switch mounting MKK/MKR -065/-080/-110/-140-NN-3	124
Product description MKR-165-NN-2	52	Switch mounting arrangement MLR-080/-110-NN-3	124
Structural design	53	Switch mounting arrangement MKR-145-NN-3	125
Technical data	54	Inductive sensors, mechanical	
Configuration and ordering	62	switches and accessories (MKK/MKR/MLR)	126
MKR-040-NN-3	62	Mounting examples of switches	127
MKR-065-NN-3	64	Switch mounting	128
MKR-080-NN-3	66	Socket and plug, cable channel	130
MKR-110-NN-3	68	Switch system accessories	132
MKR-140-NN-3	70	Sensors	132
MKR-165-NN-2	72	Switches	142
Dimensional drawings		Extensions	146
MKR-040/-065/-080/-110/-140/-NN-3	74	Connectors	148
MKR-165-NN-2	80	Adapters	149
		Distributors	150
		Combination examples	154
		Integrated measuring system IMS-A	156
Linear modules	82	Additional information	158
MKR-xxx-NN-3 without drive / support axle	82	Operating conditions	158
Linear modules MLR	84	Lubrication-MKx-165-NN-2	159
Product description MLR-xxx-NN-3	84	Lubrication-MLR-xxx-NN-3	159
Structural design	85	Lubrication MKx-xxx-NN-3	160
Technical data	86	Documentation	162
Configuration and ordering	90	Parameterization (start-up)	164
MLR-080-NN-3	90	Project planning/calculation	166
MLR-110-NN-3	92	Calculation principles	166
Dimensional drawings MLR-080/-110/-NN-3	94	Calculation example MKK with timing belt side drive	176
Linear modules MKR-145	98	Calculation example MKR with gear reducer	179
Product description MKR-145-NN-3	98	Abbreviations	182
Structural design	99	Ordering example MKK-080-NN-3	184
Technical data	100	Inquiry/order form MKK-xxx-NN-3	185
MKR-145-NN-3	102	Further information	186
MKR-145-NN-3 Dimensional drawings	104	Notes	188

General product description

Product description MKK/MKR/MLR-xxx-NN-3

The new product generation 3 (MKK/MKR/MLR-XXX-NN-3) of the Rexroth linear modules is based on the consistent further development of the previous series. The usual Rexroth performance features have been enhanced once again in terms of backward compatibility.

Linear modules can be delivered complete with motors, controllers and control units.

Structural design

- Ready-to-install linear modules in any length up to L_{max}
- Extremely compact aluminum profile with integrated Rexroth Ball rail systems (MKK/MKR) or cam roller guides (MLR)
- Identical exterior profile dimensions between Linear modules MKK, MKR, MLR
- Various carriage versions.
- Individual lubrication versions for connection to central lubrication systems

Attachments (range of accessories)

- Sensors and extension cables
- Switches (proximity or mechanical)
- Switch tab
- Socket and plug
- Aluminum profile cable channel
- Clamping fixtures and sliding blocks
- Connecting shafts
- Connection technology for linear motion systems

Further highlights

- Flexible thanks to selectable options
- Center holes for simple combination with other linear motion systems and connection elements
- Available in two material pairings ALST (aluminum –steel version) and ALCR (aluminum/steel hard chrome plated version) for MKK/MKR.
- Optionally selectable absolute length measuring system IMS-A (MKx-080/-110/-140)
- Magnetic field sensors can be mounted in frame/profile slot
- Motor attachment via flange and coupling or via timing belt side drive
- Planetary gearbox with various gear ratios
- Servo motor

Applications

- Pick and place
- Handling systems
- Placement systems, palletizers
- Machine tool feed units
- Inspection and analysis systems
- Feed units in transfer lines
- Motion units

Linear module MKK with Rexroth ball rail system and ball screw assembly

- Drive via precision ball screw assembly, either in accuracy class T7 or T5
- Spindle support (only suitable for horizontal installation position) to reach high speeds with large overall lengths (MKK-080/-110/-140) optionally available.
- Installation elements are protected by a plastic strip (MKK-040 / -065) or corrosion resistant steel strip (MKK-080/-110/-140)
- Repeatability up to +/- 0.005 mm

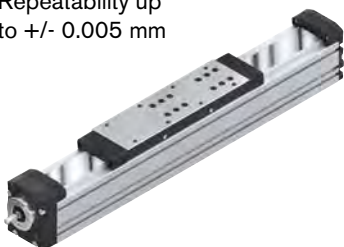

Linear module MKR with a ball rail system and belt drive

- Realization of greater lengths of up to 9,800 mm
- High performance toothed belt (AT profile) for high travel speeds of up to 5 m/s
- Installation elements are protected by a plastic strip (MKK-040 / -065) or corrosion resistant steel strip (MKR-080/-110/-140)
- Repeatability up to +/- 0.05 mm



Linear module MLR with cam roller guide and belt drive

- Realization of greater lengths of up to 10,000 mm
- High performance toothed belt (AT profile) for high travel speeds of up to 10 m/s
- Installation elements are protected by a toothed belt strip
- Repeatability up to +/- 0.05 mm



Product description MKK/MKR-165-NN-2

Rexroth linear modules of product generation 2 (MKx-165-NN-2) are precise, ready-to-install guide systems with high performance features in compact dimensions.

Linear modules can be delivered complete with motors, controllers and control units.

Structural design

- Ready-to-install linear modules in any length up to Lmax
- Extremely compact aluminum profile with integrated Rexroth ball rail systems
- Identical exterior profile dimensions between linear module types MKK and MKR
- Aluminum carriages with T-slots

Attachments

- Switches (proximity or mechanical)
- Socket and plug
- Aluminum profile cable channel

Attachments (range of accessories)

- Clamping fixtures and sliding blocks
- Connecting shafts
- Connection technology for linear motion systems
- Sensors and extension cables

Further highlights

- Flexible thanks to selectable options
- Central one-point lubrication of the Rexroth ball ball rail system and the Rexroth precision ball screw assembly (MKK) from both sides; Only suitable for grease lubrication with a manual grease gun.
- With bellows cover on MKK-165
- Motor attachment via flange and coupling or via timing belt side drive
- Planetary gearbox with various gear ratios
- Servo motor

Applications

- Pick and place
- Handling systems
- Placement systems, palletizers
- Machine tool feed units
- Inspection and analysis systems
- Feed units in transfer lines
- Motion units

Linear module MKK with Rexroth ball rail system and ball screw assembly

- Drive via precision ball screw assembly Accuracy class T7
- Installation elements are protected by a bellows cover
- Repeatability of up to +/- 0.005 mm

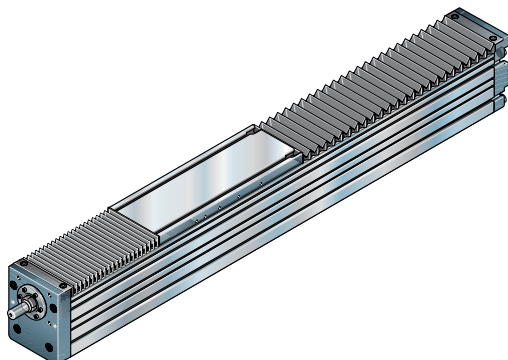

Linear module MKR with a ball rail system and belt drive

- Realization of greater lengths of up to 12,000 mm
- High performance toothed belt (AT profile) for high travel speeds of up to 5 m/s
- Repeatability of up to +/- 0.05 mm

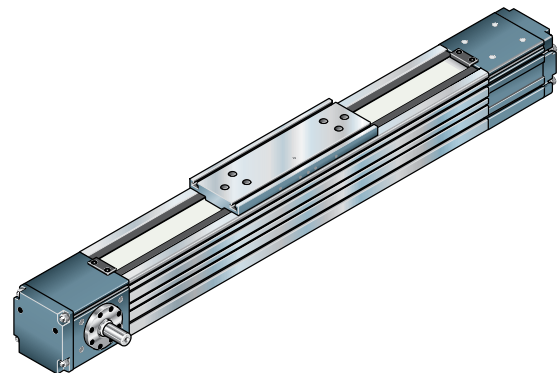

General product description

Product description MKR-145-NN-3

Rexroth linear modules are precise, ready-to-mount guide systems that combine high-performance characteristics with compact dimensions. Rexroth provides a favorable price/performance ratio and fast delivery times.

Linear modules can be delivered complete with motors, controllers and control units.

Structural design

- Ready-to-install linear modules in any length up to L_{\max}
- Realization of greater lengths of up to 6,000 mm
- Rigid aluminum profile frame with Rexroth ball rail system with cover strip
- Ball runner block with moderate preload (Preload class C1)
- Aluminum carriages with T-slots and centering holes
- Economical maintenance thanks to the one-point lubrication feature (grease lubrication or oil lubrication) from both sides via the carriage
- High-performance toothed belt (AT profile) for high drive torques with simultaneously high rigidity

Attachments

- Planetary gearbox with various gear ratios
- Attachment kits for motor according to customer specification
- Servo motor
- Magnetic field sensors for easy assembly
- Switches proximity or mechanical, cable channel, Socket-plug and extension cables in the range of accessory products

Further highlights

- Center holes also in frame profile for simple combination with other linear motion systems and connection elements
- Standard with integrated solenoid switch for magnetic field sensors
- Extensive accessories for connection and clamping elements and connecting shafts
- Nameplate with parameters for easy start-up

Applications

- Pick and place
- Handling systems
- Placement systems, palletizers
- Machine tool feed units
- Feed units in transfer lines



Product description – omega modules OBB

Omega modules are ready-to-install linear axes for any installation position in freely configurable lengths of up to 5,500 mm. Omega modules (OBB) with ball rail system and belt drive for speeds of up to 5.0 m/s.

Omega modules can be delivered complete with motors, controllers and control units.

Structural design

Due to the structural design, omega modules are particularly suited to applications where the frame extends into the working area.

- Frame from anodized aluminum profile of high inherent rigidity
- Integrated Rexroth ball rail system
- Carriage from a aluminum profile with ball runner blocks
- Driven by belt drive for travel speeds of up to 5 m/s

Attachments

- Switches (proximity and mechanical)
- Socket and plug
- Aluminum profile cable channel

Further highlights:

- The Rexroth ball rail system features one-point lubrication from both sides (only suitable for grease lubrication with a manual grease gun)
- With center holes in the carriage and on the end plates
- Driven by a toothed belt for high dynamics and high travel speeds
- Pneumatic clamping unit is optional
- With planetary gearbox (PG) or angular planetary gearbox (WPG) with various gear ratios
- Servo motor

Application areas

- Pick and place
- Handling systems

For more information, see the catalog "OBB omega modules" R999001178



OBB as a horizontal axis

Installation case: Carriage moves
(fixed frame)



OBB as a vertical axis

Installation case: Frame moves
(fixed carriage)

General product description

Linear modules delivery form

Product generation 3:

Linear modules with a ball screw drive or belt drive are delivered fully assembled.

Gear/motor attachment interface:

If a combination of attachment interface, gears and motor has been selected, the attachment of the components is done as shown in the figure below. When ordering linear modules with only an attachment interface (without gears and motor!), not all parts can be mounted. Final assembly must then be carried out by the customer. All required instructions and parameters for professional assembly are included. The installation version is selected and determined during product configuration, and it is a part of the order key.

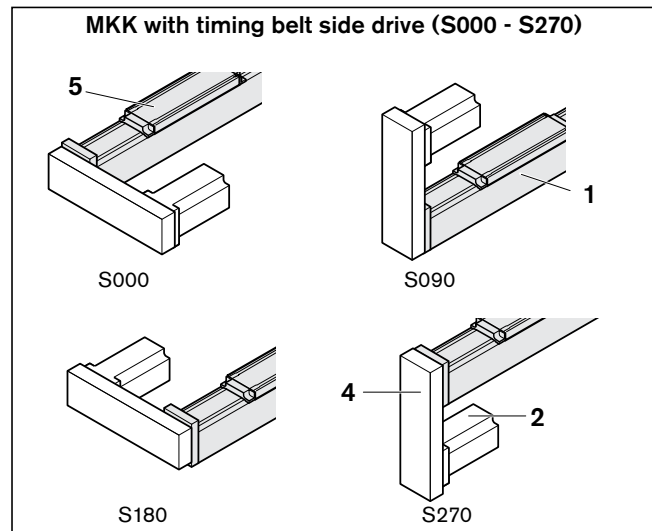
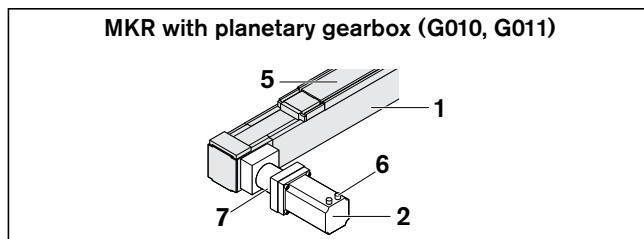
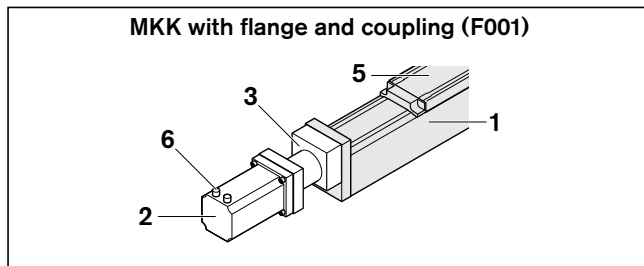

Motor connector position

- Linear module in horizontal installation position (carriage at the top)
- View toward the motor from the rear
- Selectable motor connector locations, see section "Configuration and ordering"

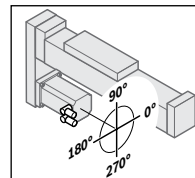

Example:
Timing belt side drive S270
Motor connector position 180°

Integrated measuring system

For further information, see the "Integrated Measuring System" chapter

Switching system

Magnetic sensors are included as loose parts. Further switching system components can be ordered from the range of accessory products. The exact setting of the position must be carried out before start-up. See the section titled "Switching system".

Lubrication

On delivery, linear modules of product generation 3 are supplied with initial greasing, preserved or prepared for connection to a central lubrication system according to the optionally selected lubricant version. Information about lubricants are found in the chapter Lubrication.

Documentation

Each linear module is supplied with the appropriate documentation.

Product generation 2 (MKK/MKR-165-NN-2):

Linear modules with a ball screw drive or belt drive are delivered fully assembled.

Motor attachment - motor:

If a combination of motor mounting and motor has been chosen, the attachment of the components is done as shown in the figure below. When ordering linear modules only with a motor mounting (without motor!), not all parts can be mounted. Final assembly must then be carried out by the customer. All required instructions and parameters for professional assembly are included.

The installation version is selected and determined during product configuration, and it is a part of the order key.

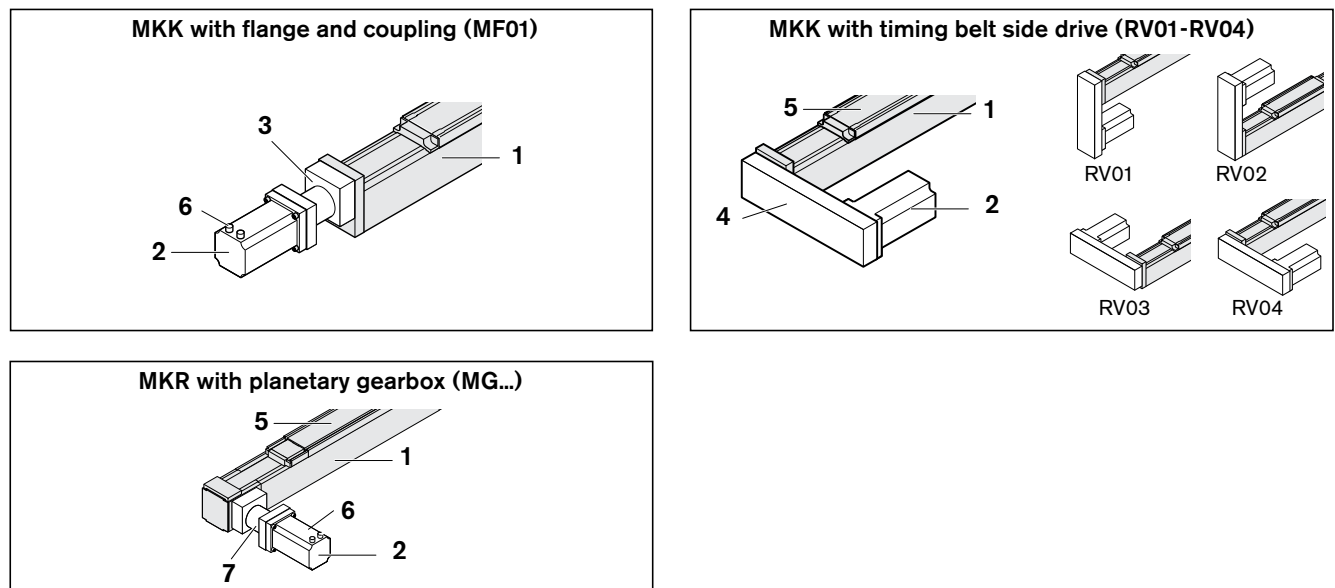

Motor connector position

An individually selectable motor connector position is not configurable for product generation 2 linear modules, therefore a standard position is specified upon delivery. Selectable motor connector positions, see chapter "Configuration and ordering".

Switching system

Cable channel, switch, switching cam and socket with plugs are included as loose parts.

Lubrication

Product generation 2 linear modules are delivered with initial greasing. Information about lubricants are found in the chapter Lubrication.

Documentation

Each linear module is supplied with the appropriate documentation.

- 1 Linear module
- 2 Motor
- 3 Flange and coupling
- 4 Belt side drive
- 5 Carriage
- 6 Motor connector
- 7 Gearing

Linear modules MKK

Product description MKK-xxx-NN-3

Features

- Ready-to-install linear modules in any length up to L_{max}
- Extremely compact aluminum profile with integrated Rexroth ball rail system.
- ball rail system with moderate pre-tensioning (pre-tensioning class C1)
- Driven by precision Rexroth ball screw assembly (BASA) in rolled design, optionally in tolerance grade T7 or T5 according to ISO 3408-3 with zero-backlash cylindrical single nut
- High travel speeds thanks to large leads with high precision over long distances
- Carriage made of aluminum, in two design versions, with T-slots or threaded holes and with centering holes in each case
- Protection of the guideway and drive components by sealing strip (plastic strip for MKK-040/-065, corrosion resistant steel strip for MKK-080/-110/-140)
- Economical maintenance thanks to one-point lubrication feature (grease or oil lubrication) on either one or both sides of the carriage
- Repeatability of up to ± 0.005 mm

Further highlights

- Available in two material versions, ALST (aluminum/steel version) and ALCR (aluminum/steel hard chrome plated version).
- Center holes also in frame for simple combination with other linear motion systems and connection elements
- Screw support (SPU) to reach high speeds with a large travel range (MKK-080/-110/-140) optionally available
- Absolute length measuring system IMS-A directly integrated into the guide system (MKK-080/-110/-140)
- Standard with integrated solenoid switch for magnetic field sensors
- Extensive accessories for connection and clamping elements
- Nameplate with parameters for easy start-up

Attachments

- Motor attachment with flange and coupling or via a timing belt side drive
- Attachment kits for motor according to customer specification
- Servo motor
- Magnetic field sensors for easy assembly directly on the profile frame
- Switch (proximity or mechanical) cable channel, socket-plug and extension cable in the accessories program

Carriage with thread



Carriage with T-slots



Product description
Screw support (SPU)

for MKK-080/-110/-140

The Screw Support (SPU) offers the following advantages:

- Screw support for horizontal applications (please request for vertical applications)
- Screw support can be selected as standard option via the option number.
- A maximum of two screw support pairs is possible.
- High speed over long lengths of up to 5,400 mm.
- Guidance of the screw supports in the frame.
- Screw supports are maintenance-free.
- Screw supports are protected by optionally selectable sealing strip.

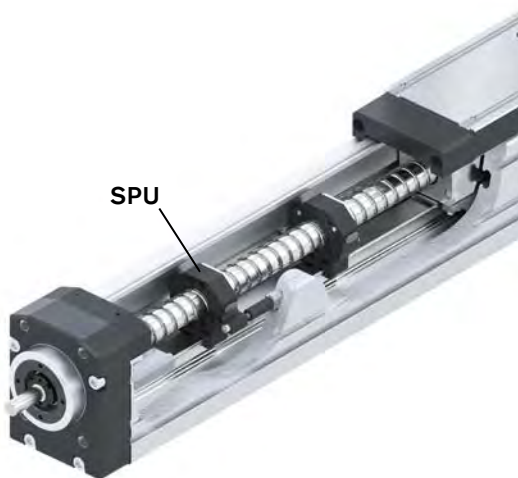

Product description
Integrated measuring system

for MKK-080/-110/-140

The IMS-A measuring system offers the following advantages:

- No additional space required.
- No additional mounting surfaces required for the measuring system.
- No measurement inaccuracies due to parallelism offset between the measuring system and the guide system.
- Full integration of the measuring system components into the guide means no complex mounting or tuning work is needed.
- The runner block, scanner and guide rail with scale can be replaced individually during servicing.
- Interfaces: HIPERFACE (HF) or DRIVE-CLiQ (DQ).
- Connecting cable directly on the side of the carriage.
- For further information, see the "Integrated Measuring System" chapter

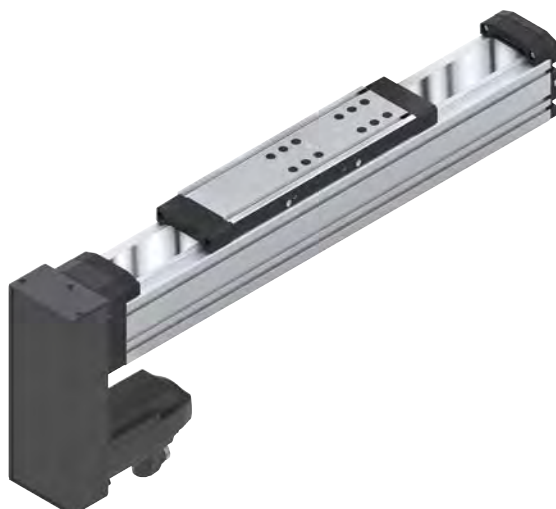
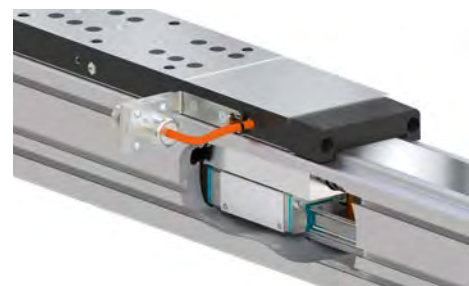

Motor attachment with timing belt side drive



Motor attachment with flange coupling

Linear modules MKK

Product description MKK-xxx-NN-3

Material pairing

ALST:

- Frame, carriage and end blocks made of anodized aluminum (AL)
- MKK-065/-080/-110/-140: ball guide rail, ball runner block and Rexroth ball screw assembly made of rolling bearing steel (ST)
- MKK-040: Ball guide rail and ball runner block of rust and acid resistant material. Ball screw assembly made of rolling bearing steel (ST)
- Angular-contact ball bearing and deep-groove ball bearing of the screw drive bearing made of rolling bearing steel

ALCR:

- Frame, carriage and end blocks made of anodized aluminum (AL)
- MKK-065/-080/-110/-140: Ball guide rail and ball screw assembly made of rolling bearing steel with corrosion resistant coating, matte-silver finish, hard chrome plated (Resist CR), ball runner block from corrosion resistant steel (Resist NR)
- MKK-040: Ball guide rail and ball runner block of rust and acid resistant material. Ball screw assembly made of rolling bearing steel with corrosion resistant coating, matte-silver finish, hard chrome plated (Resist CR).
- Angular-contact ball bearing and deep-groove ball bearing of the screw drive bearing made of rolling bearing steel

Lubrication versions

LSS: (Initial lubrication done at the factory)

- Initial standard greasing done at the factory, suitable for normal environmental conditions.
- Simple relubrication via manual grease gun.

MKK-065/-080/-110/-140:

- Grease lubricant Dynalub 510, lithium-based high-performance grease of the NLGI grade 2 according to DIN 51818 (KP2K-20 according to DIN 51825)

MKK-040:

- Grease lubricant Dynalub 520, lithium-based high-performance grease of the NLGI grade 00 according to DIN 51818 (GP00K-20 according to DIN 51826)

LPG: (Corrosion prevention, no initial lubrication)

- Linear module without initial greasing done at the factory.
- Ball rail system and ball screw drive only with corrosion prevention.
- Basic lubrication required

LCF: (prepared for connection to central lubrication systems with liquid grease)

- For liquid grease, NLGI grade 00 lithium-based high-performance grease according to DIN 51818 (GP00K-20 according to DIN 51826)
- Only use liquid grease lubrication with single-line total-loss lubrication systems via piston distributors.
- Basic lubrication required

LCO: (prepared for connection to central lubrication systems with oil)

- Ball runner block and ball screw drive nut with integrated non-return valves
- Only use oil lubrication with single-line total-loss lubrication systems via piston distributors.
- Basic lubrication required

Product description MKK-165-NN-2

Features

Linear modules with Rexroth ball rail system and ball screw assembly for high positioning accuracy and repeatability as well as thrust forces.

The Linear modules comprise:

- A compact, anodized aluminum profile (frame)
- The integrated Rexroth ball rail system
- A carriage with T-slots for fixtures, with central lubrication point
- The Rexroth ball screw assembly set to zero-clearance (also available without a drive)
- Mountable switches
- Servo motor
- Flange, coupling or timing belt side drive for motor attachment
- Cover provided by the bellows

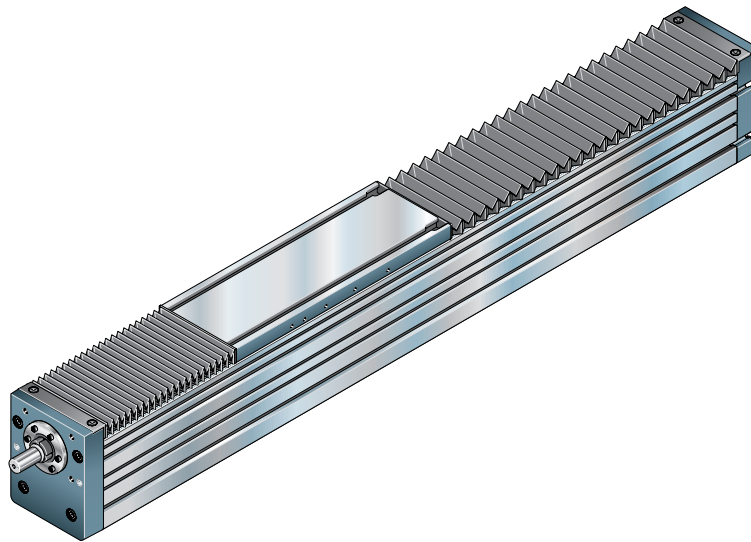

Linear modules MKK

Structural design

- 1 Rexroth ball screw assembly (BASA) with zero-backlash cylindrical single nut
- 2 End block fixed bearing
- 3 Sealing strip on MKK-040/-065/-080/-110/-140
- 4 Carriage with runner block
- 5 Strip fixing
- 6 End plate floating bearing
- 7 Frame

Attachments:

- 8 Switching angle
- 9 Proximity switch
- 10 Mechanical switch
- 11 Cable channel
- 12 Socket-plug
- 13 Bellows cover for MKK-165
- 14 Magnetic field sensor

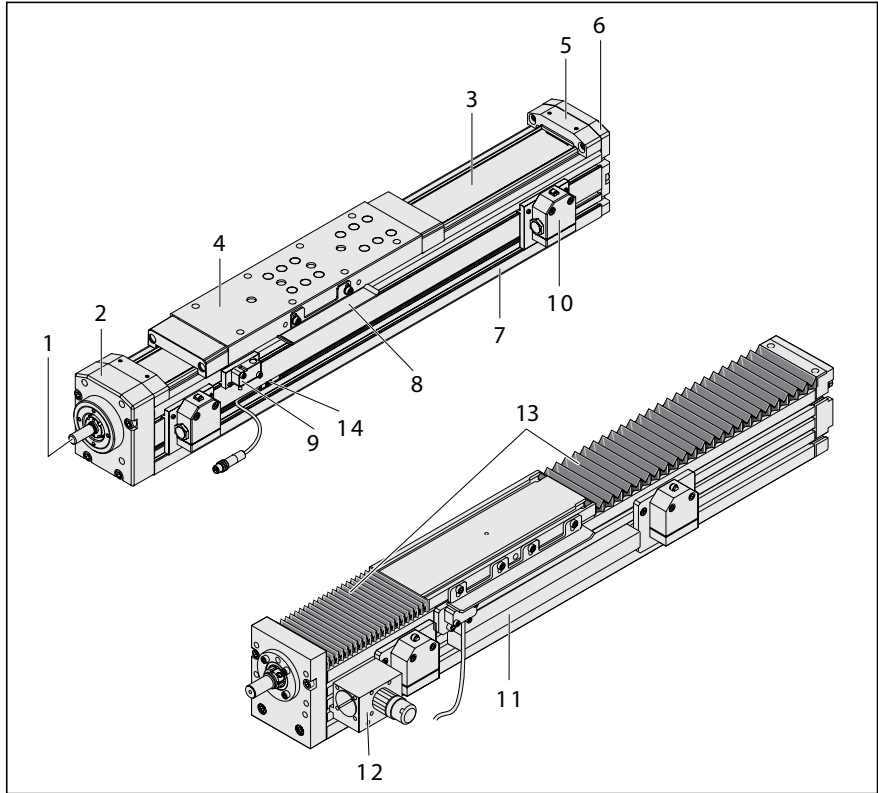

- 15 Flange
- 16 Servo motor
- 17 Belt side drive

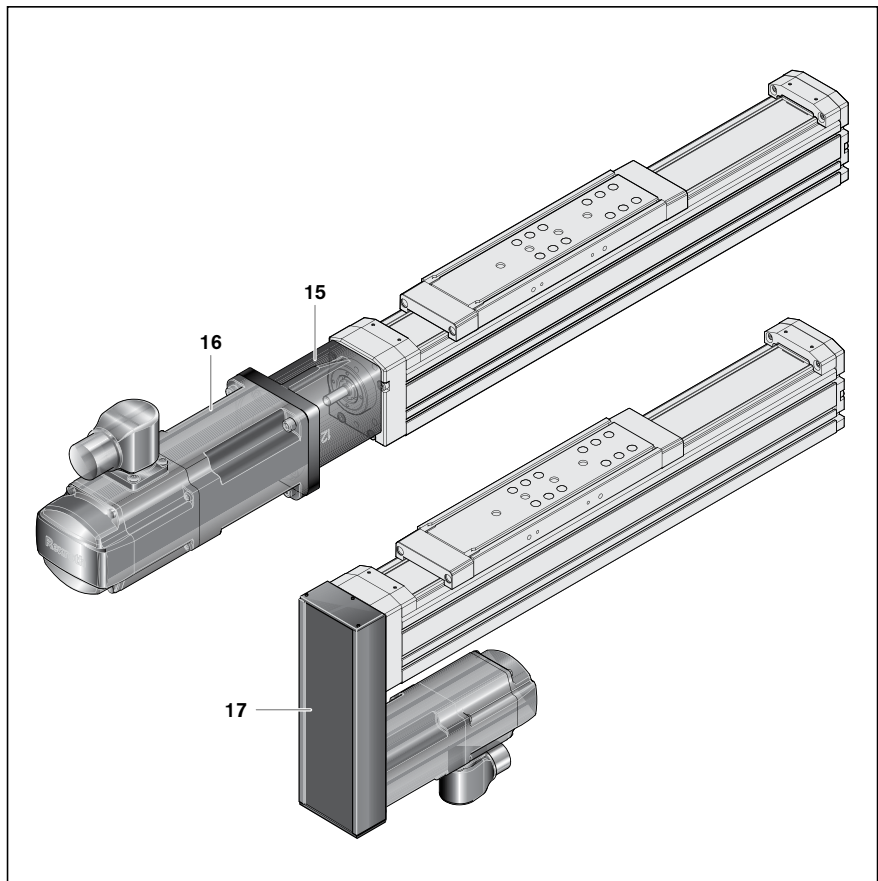

Motor attachment with flange and coupling

A motor can be attached via a flange and coupling to all linear modules equipped with a ball screw drive.

The flange serves to fasten the motor to the linear module and acts as a closed housing for the coupling.

The coupling transmits the motor drive torque free of distortive stresses to the linear module's drive shaft.

Our standard couplings compensate for the system's thermal expansion.

- 1 Motor
- 2 Flange
- 3 Coupling
- 4 Linear module

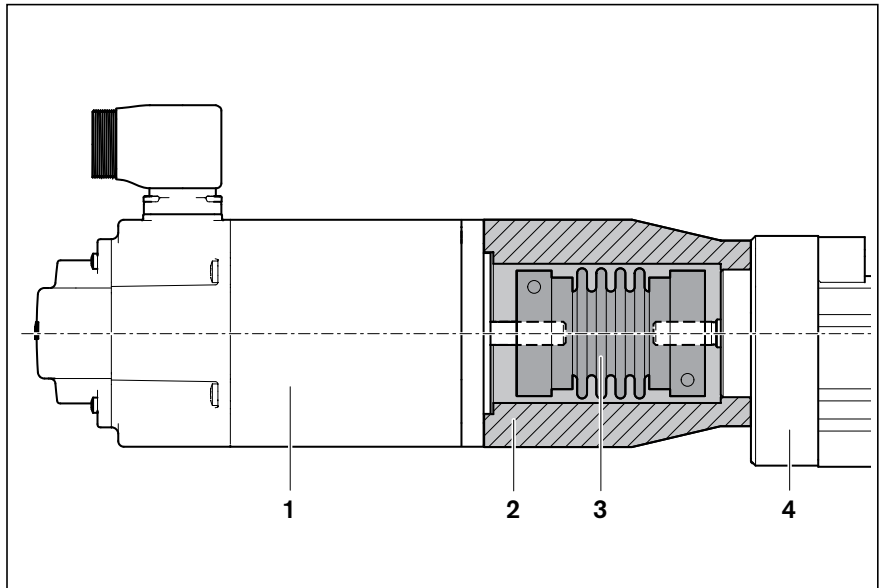

Structural design belt side drive

On all linear modules with a ball screw drive the motor can be attached via a timing belt side drive.

This makes the overall length shorter than when attaching the motor with flange and coupling.

The space-saving, closed pulley housing provides protection for the belt and acts as a motor bracket.

In addition, various gear ratios are available.

The belt side drive can be mounted in four different directions:

- 1 Pulley housing from anodized aluminum profile
- 2 Partially with support bearing for Rexroth ball screw assembly screw journal
- 3 Linear module
- 4 Belt drive with gear ratio: $i = 1; i = 1,5; i = 2$
- 5 Servo motor
- 6 Belt pulley
- 7 Cover
- 8 Belt pulleys attached using tensioning units
- 9 Cover plate

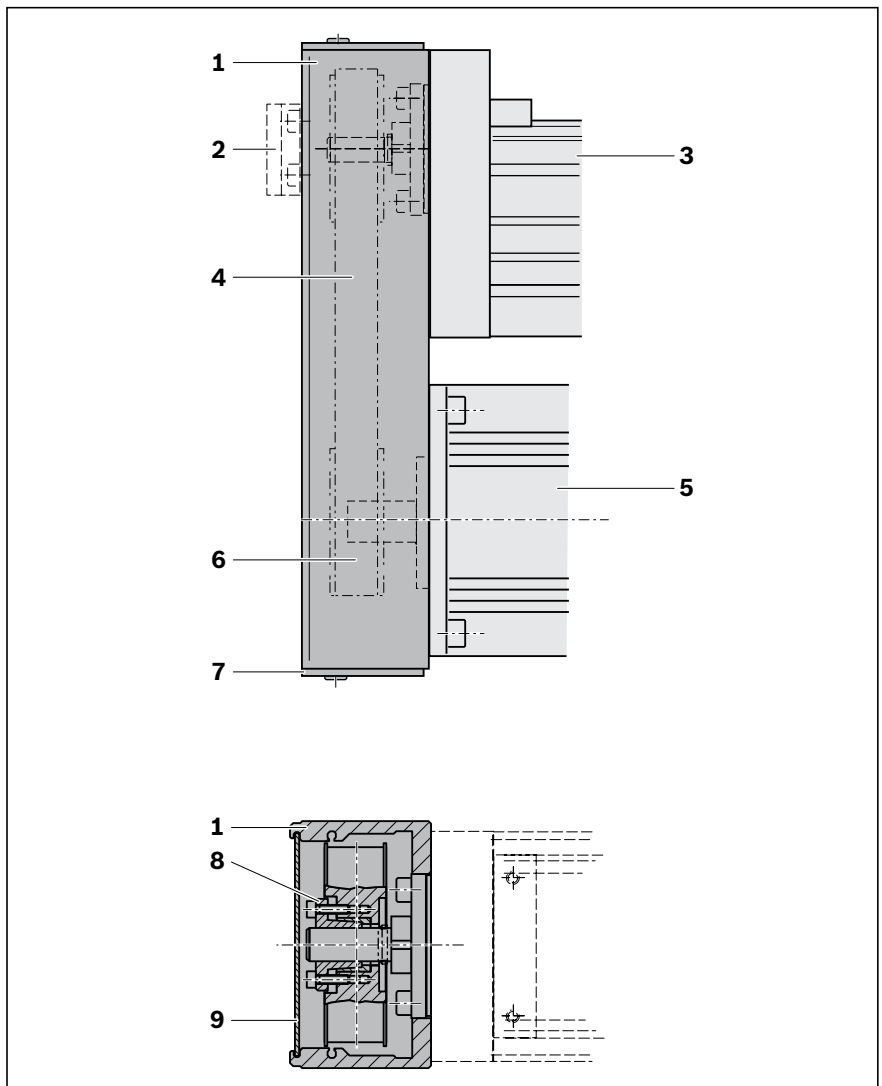

Linear modules MKK

Technical data

General technical data

Observe the "Project planning/calculation" chapter!

MKK	Number of carriages	Carriage		Rexroth ball screw assembly $d_0 \times P$		Dynamic characteristics					Maximum permissible loads		
						Dynamic load capacities			Dynamic load moments		Max. permissible moments		
						C_{gw} (N)	C_{bs} (N)	C_{fb} (N)	M_t (Nm)	$M_L^{(2)}$ (Nm)	$M_{x\ max}$ (Nm)	$M_{y\ max}^{(3)}$ (Nm)	$M_{z\ max}^{(3)}$ (Nm)
L_{ca} (mm)	$L_W^{(1)}$ (mm)	d_0 (mm)	SI (mm)										
-040-NN-3	1	135	-	12	2	3 750	2 420	4 000	22.3	93.8	11	53	53
					5		4 100						
					10		2 700						
-065-NN-3	1	190	-	16	5	16 000	13 320	13 400	154	533	62	213	213
					10		10 350						
					16		10 080						
	2	2 x 190	variable min = 210 max = 750		5	32 000	13 320		308	8 x Lw	124	3.2 x Lw	3.2 x Lw
					10		10 350						
					16		10 080						
-080-NN-3	1	260	-	20	5	38 000	15 480	16 900	487	1 843	195	737	737
					10		15 210						
					20		14 400						
					40		12 600						
	1 (with IMS)	360	-		5	76 000	15 480		974	19 x Lw	390	7.5 x Lw	7.5 x Lw
					10		15 210						
					20		14 400						
					40		12 600						
	2	260	variable min = 320 max = 960		5	93 000	23 310		1 332	23.2 x Lw	528	9.2 x Lw	9.2 x Lw
					10		34 200						
					20		21 240						
					32		21 060						
-110-NN-3	1	305	-	32	5	46 500	23 310	26 000	666	2 235	264	894	894
					10		34 200						
					20		21 240						
					32		21 060						
	1 (with IMS)	430	-		5	93 000	23 310		1 332	23.2 x Lw	528	9.2 x Lw	9.2 x Lw
					10		34 200						
					20		21 240						
					32		21 060						
	2	305	variable min = 375 max = 1095		5	93 000	23 310		1 332	23.2 x Lw	528	9.2 x Lw	9.2 x Lw
					10		34 200						
					20		21 240						
					32		21 060						

- 1) Variable centerline-to-centerline distance defined by customer-built mounting base.
Centerline-to-centerline distance freely selectable between minimum and maximum distance in millimeters steps.
- 2) Determine dynamic longitudinal load moment M_L with variable carriage centerline-to-centerline distance according to the selected centerline-to-centerline distance.
- 3) Determine maximum permissible longitudinal moments $M_{y\ max}$ and $M_{z\ max}$ at variable carriage centerline-to-centerline distance according to the selected centerline-to-centerline distance.
- 4) Minimum required travel distance to ensure a reliable lubrication distribution.
For operating conditions, see the section titled "Additional information".
If values are not met, please contact Bosch Rexroth.
- 5) Additional length L_{ad} for version with screw support (SPU) 1 pair
- 6) Additional length L_{ad} for version with screw support (SPU) 2 pair
- 7) Maximum permissible length L_{max} for version with screw support (SPU)

Length calculation ➡ "Project planning/calculation" chapter
Short product names ➡ "Abbreviations" chapter.

Size -140 and -165 ➡ next page

	Max. permissible forces $F_{y \max} / F_{z1 \max} / F_{z2 \max}$ (N)	Additional length L_{ad} (mm)	Min. travel range $s_{\min}^{4)}$ (mm)	Max. length L_{\max} (mm)	Application point of the effective force z_1 (mm)	Moved mass of system m_{ca} (kg)	Constants mass calculation		Planar moment of inertia				
							$k_g \text{ fix}$ (kg)	$k_g \text{ var}$ (kg/mm)	I_y (cm ⁴)	I_z (cm ⁴)			
	1 875	25	50	1 000	42	0.39	0.26	0.0028	11.98	11.56			
	6 400	34	60	2 500	67	1.57	1.00	0.0075	80.3	90.3			
	12 800					1.75							
						1.82							
						2.97							
						3.15							
	15 200	109	60	2 500	74	3.22	2.00	0.0117	183	213			
						30 400					122 ⁵⁾	3 400 ⁷⁾	2.91
													2.86
													3.14
													3.20
													3.31
													3.26
													3.54
													3.60
													5.61
	5.56												
	18 600	119	60	4 000	94	5.84	3.20	0.021	508	676			
						37 200					132 ⁵⁾	5 400 ⁷⁾	4.75
													5.01
													5.06
													5.37
													6.25
													6.51
													6.56
													6.87
													9.15
	9.41												
	178 ⁶⁾					9.46							
						9.77							

Linear modules MKK

Technical data

General technical data

Observe the "Project planning/calculation" chapter!

MKK	Number of carriages	Carriage		Rexroth ball screw assembly $d_0 \times P$		Dynamic characteristics					Maximum permissible loads			
		L_{ca} (mm)	$L_W^{1)}$ (mm)	d_0 (mm)	SI (mm)	Dynamic load capacities			Dynamic load moments		Max. permissible moments			
						C_{gw} (N)	C_{bs} (N)	C_{fb} (N)	M_t (Nm)	$M_L^{2)}$ (Nm)	$M_{x \max}$ (Nm)	$M_{y \max}^{3)}$ (Nm)	$M_{z \max}^{3)}$ (Nm)	
-140-NN-3	1	370	-	40	5	59 300	54 000	54 000	1 020	3 190	409	1 275	1 275	
					10									
					20									
					40									
	1 (with IMS)	500	-		5	118 600	54 000	54 000	54 000	2 040	29.6 x L _w	818	11.8 x L _w	11.8 x L _w
					10									
					20									
					40									
	2	370	variable min = 450 max = 1350	5	118 600	54 000	54 000	54 000	2 040	29.6 x L _w	818	11.8 x L _w	11.8 x L _w	
				10										
				20										
				40										
-165-NN-2	1	400	-	without	without	84 100	without	29 000	1 803	5 130	723	2 085	2 085	
				40	5		31 410							
					10		54 000							
					20		40 950							
					40		39 960							

- 1) Variable centerline-to-centerline distance defined by customer-built mounting base.
Centerline-to-centerline distance freely selectable between minimum and maximum distance in millimeters steps.
- 2) Determine dynamic longitudinal load moment M_L with variable carriage centerline-to-centerline distance according to the selected centerline-to-centerline distance.
- 3) Determine maximum permissible longitudinal moments $M_{y \max}$ and $M_{z \max}$ at variable carriage centerline-to-centerline distance according to the selected centerline-to-centerline distance.
- 4) Minimum required travel distance to ensure a reliable lubrication distribution.
For operating conditions, see the section titled "Additional information".
If values are not met, please contact Bosch Rexroth.
- 5) Additional length L_{ad} for version with screw support (SPU) 1 pair
- 6) Additional length L_{ad} for version with screw support (SPU) 2 pair
- 7) Maximum permissible length L_{max} for version with screw support (SPU)

Length calculation ➡ "Project planning/calculation" chapter

Short product names ➡ "Abbreviations" chapter

Max. permissible forces	Additional length	Min. travel range	Max. length	Point of force application	Moved mass of system	Constants mass calculation		Planar moment of inertia	
						$F_{y \max} / F_{z1 \max} / F_{z2 \max}$ (N)	L_{ad} (mm)	$s_{min}^{4)}$ (mm)	L_{max} (mm)
23 700	120	80	4 000	124	10.53	6.30	0.0342	1 470	1 880
					10.80				
					10.57				
					10.65				
					13.03				
					13.30				
					13.07				
					13.15				
					19.33				
					19.60				
47 400	228 ⁶⁾		5 400 ⁷⁾		19.37				
					19.45				
					16.50				
					17.30				
34 100	50	80	12 000	123	16.50	7.80	0.045	2 468	3 527
			4 000						
			17.60						
			18.40						

Linear modules MKK

Technical data

Drive data

Observe the "Project planning/calculation" chapter!

MKK	Rexroth ball screw assembly		Constants mass moment of inertia			Frictional torque ¹⁾	Max. acceleration	Max. drive torque M _p (Nm)	Max. travel speed v _{max} (m/s)
	d ₀ x P (mm)	Quantity Carriages	k _{J fix} (kgmm ²)	k _{J var} (kgmm)	k _{J m} (mm ²)				
-040-NN-3	12 x 2	1	1.274	0.013	0.101	0.09	48.4	See graphs	See graphs
	12 x 5	1	1.468	0.011	0.633	0.10	50.0		
	12 x 10	1	2.201	0.011	2.533	0.11	50.0		
-065-NN-3	16 x 5	1	4.315	0.031	0.633	0.40	50.0		
		2	5.202			0.40			
	16 x 10	1	7.754	0.031	2.533	0.40			
		2	11.300			0.50			
	16 x 16	1	15.112	0.034	6.480	0.40			
		2	24.191			0.50			
-080-NN-3	20 x 5	1	11.226	0.084	0.633	0.40	39.8		
		2	12.936			0.50			
		1 (with IMS)	11.479			0.40			
	20 x 10	1	16.628	0.084	2.533	0.50	50.0		
		2	23.467			0.55			
		1 (with IMS)	17.651			0.50			
	20 x 20	1	41.223	0.081	10.140	0.50	50.0		
		2	68.580			0.60			
		1 (with IMS)	45.276			0.50			
	20 x 40	1	139.057	0.086	40.530	0.70	50.0		
		2	248.480			0.80			
		1 (with IMS)	155.268			0.70			
-110-NN-3	32 x 5	1	49.600	0.605	0.633	1.10	17.9		
		2	52.386			1.20			
		1 (with IMS)	50.550			1.10			
	32 x 10	1	59.037	0.640	2.533	1.10	30.7		
		2	70.183			1.20			
		1 (with IMS)	62.837			1.10			
	32 x 20	1	97.623	0.639	10.140	1.00	50.0		
		2	142.204			1.10			
		1 (with IMS)	112.821			1.00			
	32 x 32	1	185.796	0.617	25.940	1.00	50.0		
		2	299.925			1.10			
		1 (with IMS)	224.703			1.00			
-140-NN-3	40 x 5	1	246.800	1.564	0.633	2.10	12.2		
		2	252.200			2.20			
		1 (with IMS)	248.400			2.10			
	40 x 10	1	263.300	1.355	2.533	2.50	16.8		
		2	284.900			2.70			
		1 (with IMS)	269.600			2.50			
	40 x 20	1	342.900	1.352	10.140	2.20	33.8		
		2	429.100			2.50			
		1 (with IMS)	368.300			2.20			
	40 x 40	1	667.300	1.342	40.530	2.30	50.0		
		2	1 012.000			2.80			
		1 (with IMS)	768.700			2.30			
-165-NN-2	40 x 5	1	217.000	1.564	0.633	2.00	12.2		
	40 x 10	1	248.000	1.355	2.533	2.40	16.8		
	40 x 20	1	381.000	1.352	10.140	2.20	33.0		
	40 x 40	1	947.000	1.342	40.530	2.60	50.0		

¹⁾ at 200 rpm

Values also valid for the carriage version with variable centerline-to-centerline distance

Drive data for motor attachment with timing belt side drive

MKK	Motor	Rexroth ball screw assembly $d_0 \times P$ (mm)	Length up to $L^1)$ (mm)	Permissible torque $M_{sd}^2)$ (Nm)		Reduced mass moment of inertia J_{sd} (10^{-6} kgm 2)		Frictional torque M_{Rsd} (Nm)	Mass m_{sd} (kg)		Belt type B_t	
				$i=1^3)$	$i=1.5^3)$	$i=1^3)$	$i=1.5^3)$		$i=1^3)$	$i=1.5^3)$	$i=1^3)$	$i=1.5^3)$
-040-NN-3	MSM019B	12 x 2	1 000	0.79	0.53	10.7	4.1	0.10	0.28	0.26	6 AT3	6 AT3
		12 x 5		1.31	0.87							
		12 x 10		1.31	0.87							
	MS2N03-B MSM031B	12 x 5		0.80	0.50	34.8	13.0	0.15	0.63	0.60	10 AT3	10 AT3
		12 x 5		1.60	1.10							
		12 x 10		1.60	1.10							
-065-NN-3	MSM041B MS2N04	16 x 5	1 100	4.31	2.87	234.4	83.6	0.40	1.45	1.32	16 AT5	16 AT5
		16 x 10	1 300	5.85	3.90							
		16 x 16	1 550	6.42	4.28							
-080-NN-3	MSM041B MS2N04	20 x 5	1 600	5.90	3.90	250.0	85.0	0.40	1.24	1.27	16 AT5	16 AT5
		20 x 10	2 000	7.60	5.00							
		20 x 20	2 500	8.30	5.50							
		20 x 20	2 500	8.30	5.50							
		20 x 40	2 500	8.50	5.70							
-080-NN-3	MS2N05	20 x 5	1 600	5.90	2.95	1 420,0	230.0	0.45	3.20	2.90	25 AT5	25 AT5
		20 x 10	2 000	7.70	3.85							
		20 x 20	2 500	8.50	4.25							
		20 x 20	2 500	8.50	4.25							
		20 x 40	2 500	8.70	4.35							
-110-NN-3	MS2N06	32 x 5	2 500	20.60	10.30	1 400,0	260.0	0.50	3.20	2.90	25 AT5	32 AT5
		32 x 10	3 200	22.80	14.60							
		32 x 20	4 300	22.80	14.60							
		32 x 32	5 400	22.80	14.60							
-140-NN-3	MS2N07	40 x 5	2 500	27.70	13.85	7 780,0	1 260,0	0.60	8.60	7.50	50 AT10	50 AT10
		40 x 10	1 800	72.00	36.00							
		40 x 20	2 200	96.30	48.15							
		40 x 40	3 000	108.90	54.45							
-165-NN-2	MS2N07	40 x 5	2 800	26.00	13.00	7 780,0	1 260.0	0.60	8.40	7.20	50 AT10	50 AT10
		40 x 10	2 400	52.00	26.00							
		40 x 20	2 400	99.30	49.60							
		40 x 40	3 300	99.30	49.60							

1) For greater lengths, the permissible drive torque is determined from the length-variable value M_p of the linear motion system in accordance with the diagram ! See the section titled "Basis of calculation".

2) Values for M_{sd} do not factor in motor torque.

3) With support bearing

Drive data for motor attachment with flange and coupling

MKK	Motor	Coupling	M_{cN} (Nm)	J_c (10^{-6} kgm 2)	m_c (kg)	Flange and coupling	
						m_{fc} (kg)	
-040-NN-3	MS2N03-B		3.7	7.0	0.075	0.26	
	MSM019B		1.9	2.1	0.039	0.13	
	MSM031B		3.7	7.0	0.075	0.29	
-065-NN-3	MS2N04		19.0	57.0	0.260	0.75	
	MSM041B		9.0	61.0	0.260	0.85	
-080-NN-3	MS2N04		19.0	57.0	0.260	1.00	
	MS2N05		50.0	210.0	0.700	1.90	
	MSM041B		14.5	63.0	0.260	0.90	
-110-NN-3	MS2N06		50.0	210.0	0.700	1.80	
-140-NN-3	MS2N07		115.0	390.0	0.900	2.80	
-165-NN-2	MS2N07		115.0	390.0	0.900	2.80	

Linear modules MKK

Technical data

Permissible drive torque M_p

The values for M_p apply under the following conditions:

- Screw journal without keyway
- No radial loads on screw journal

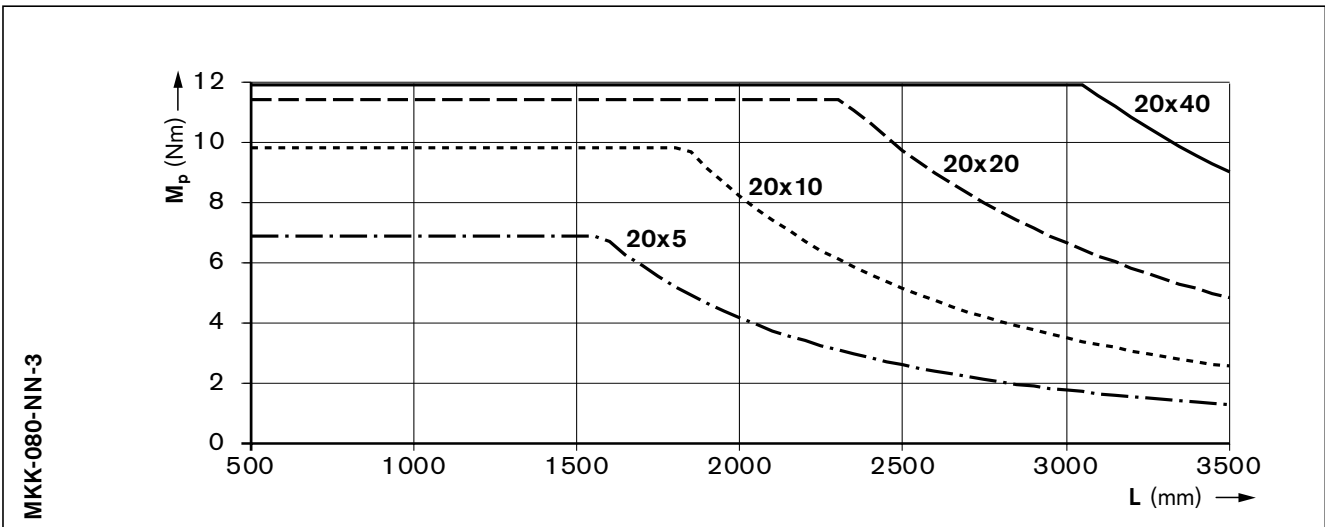
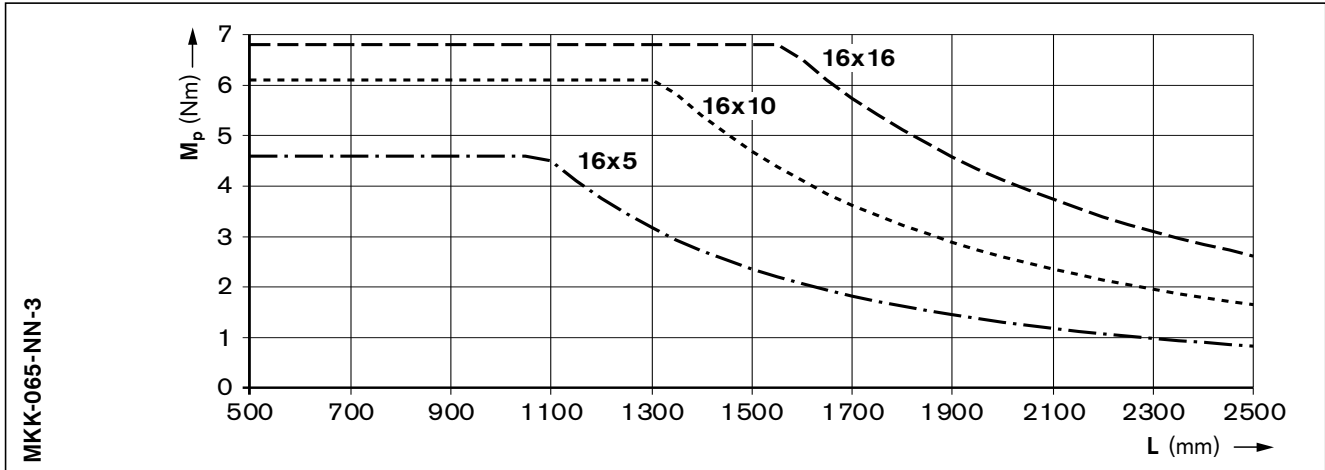
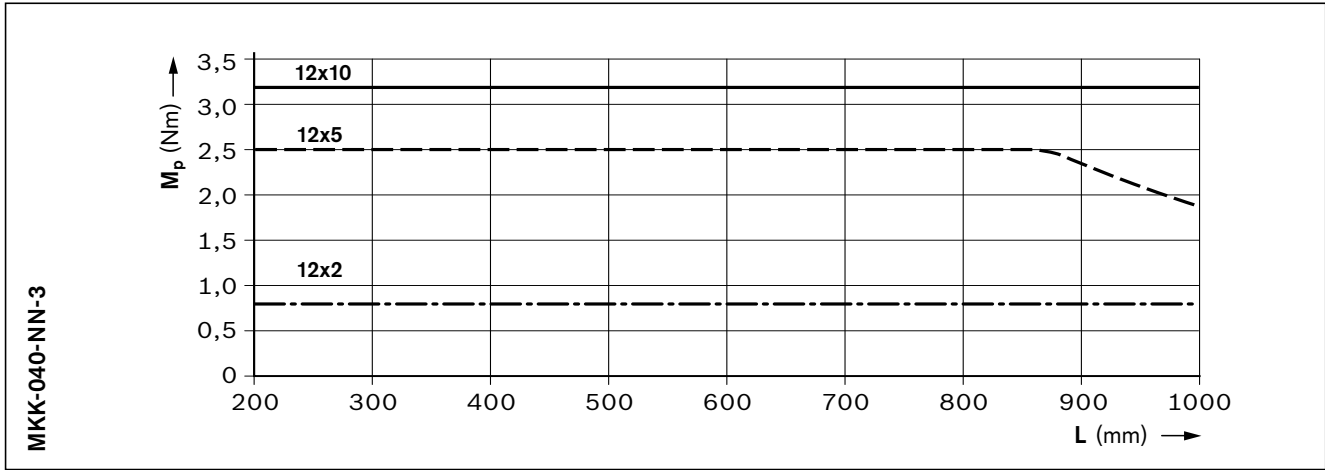

⚠ Screw journal with keyway

For reasons of stress concentration and a reduction of the effective diameter, observe the maximum value $M_p = 48 \text{ Nm}$ for drive torque! (applicable to ball screw drive 32x20 and 32x32)

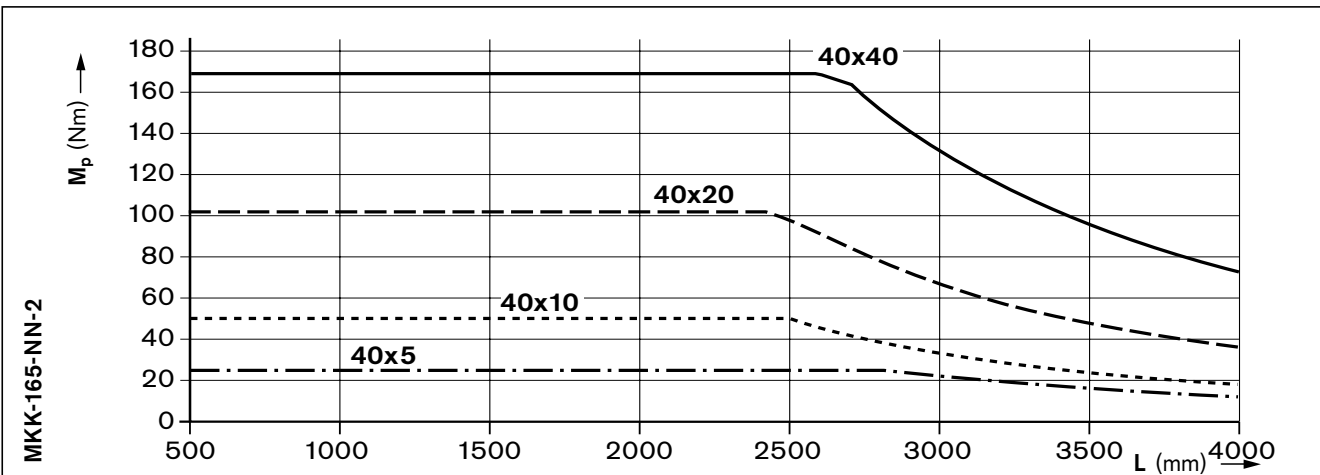
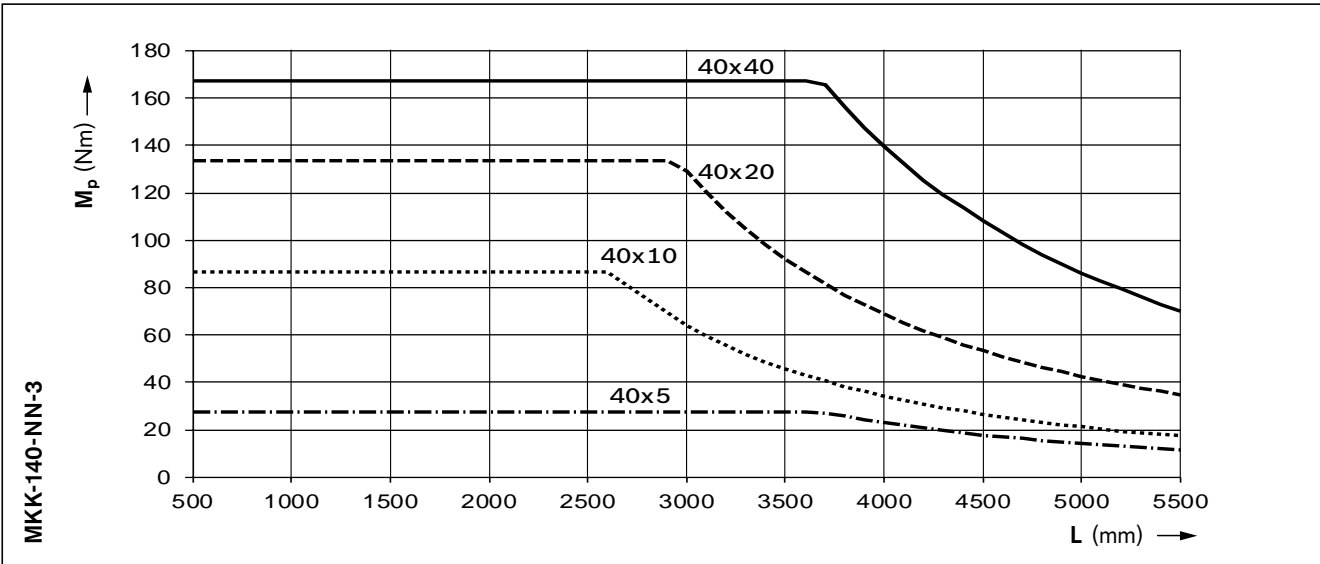
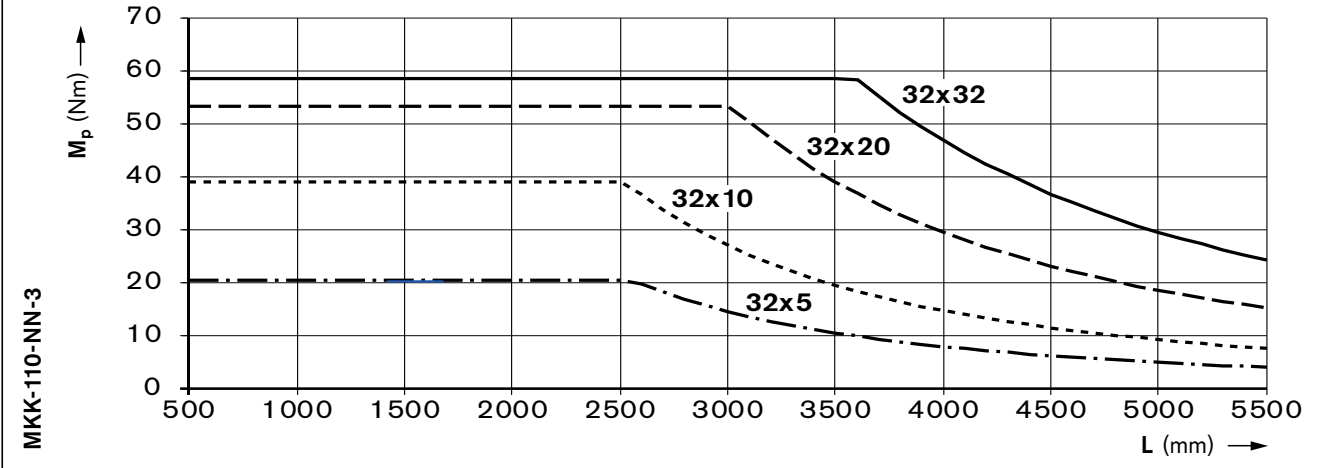

Linear modules MKK

Technical data

Permissible speed v_{max}

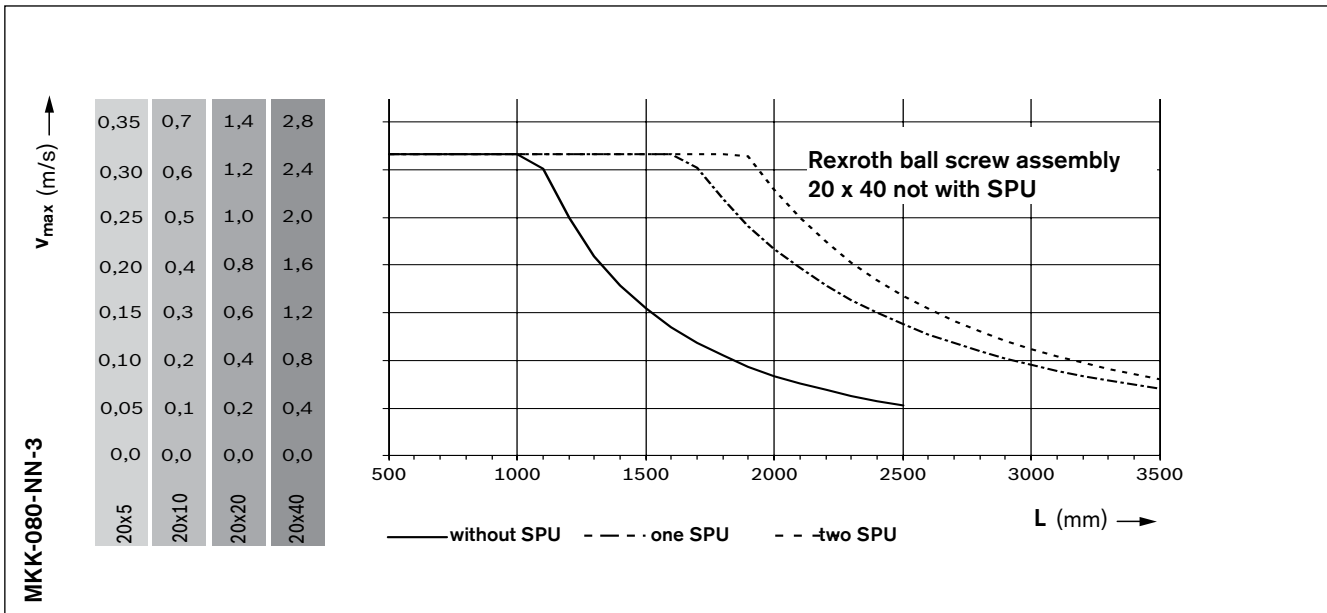
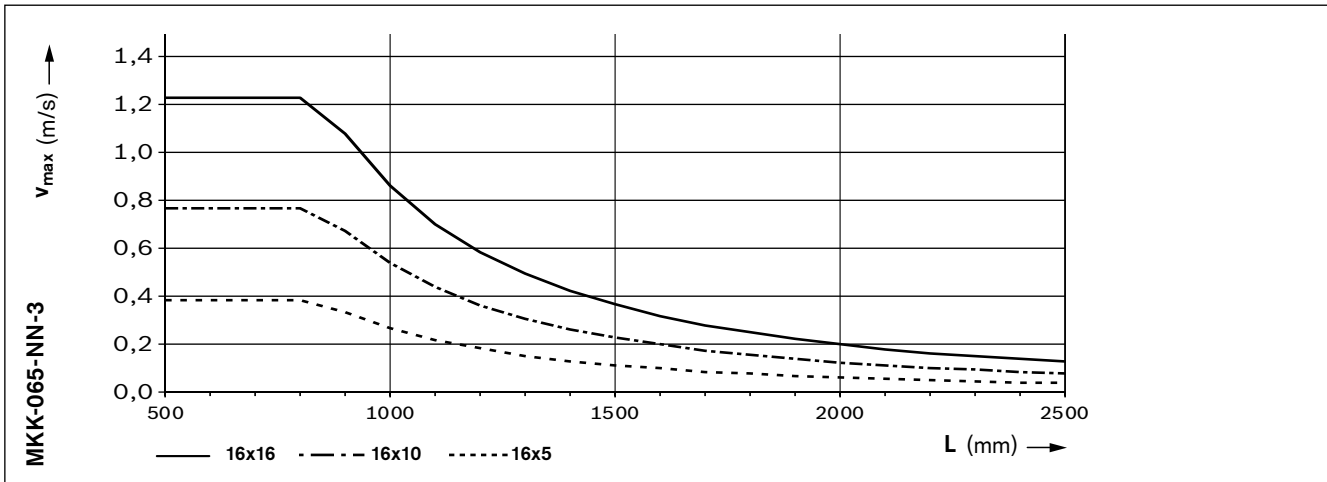
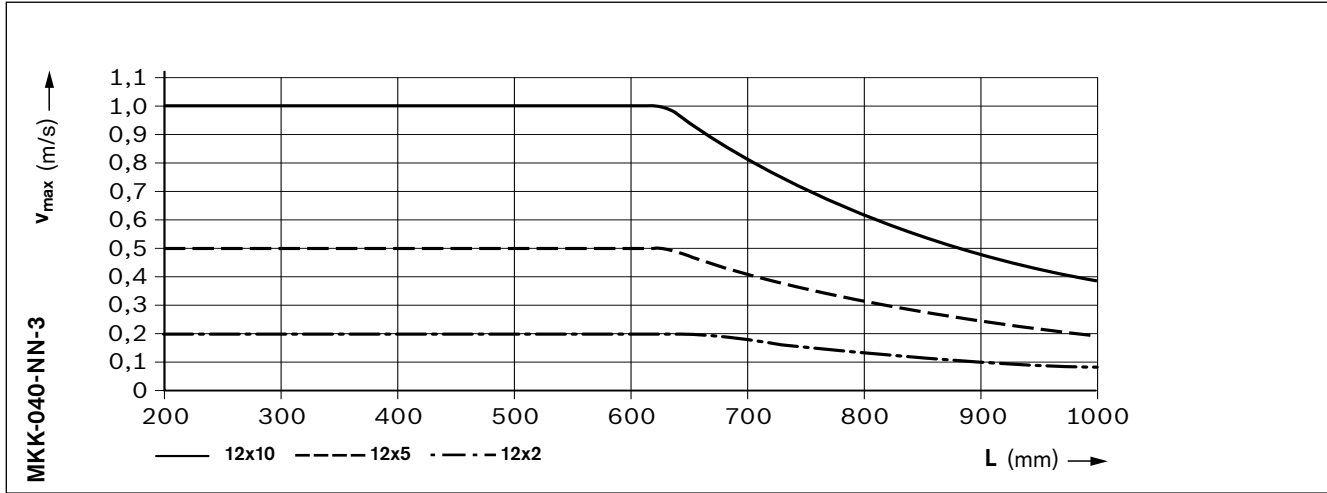

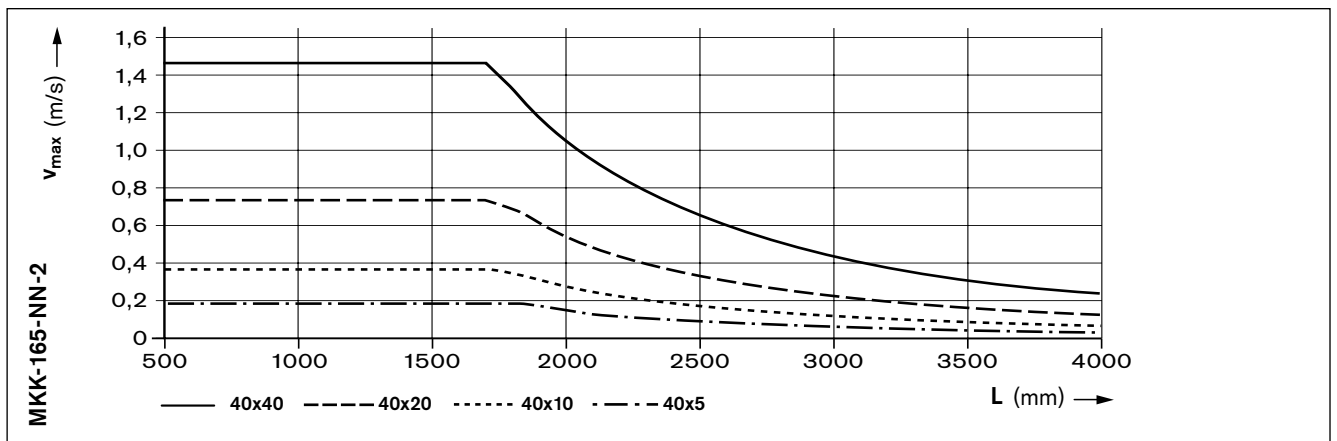
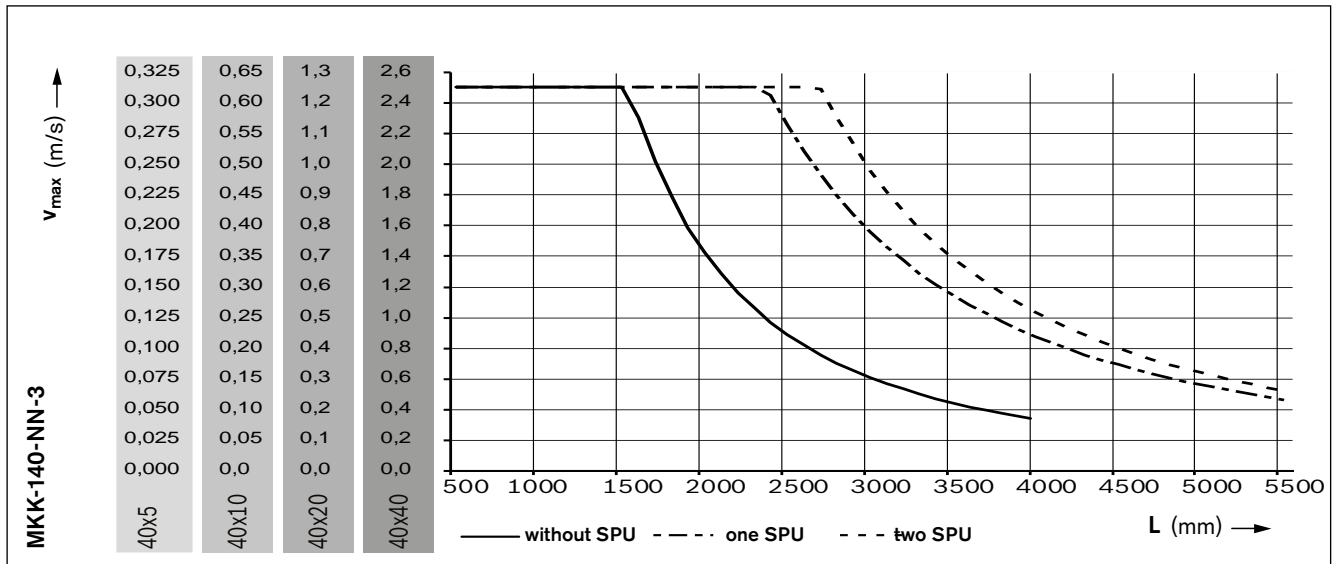
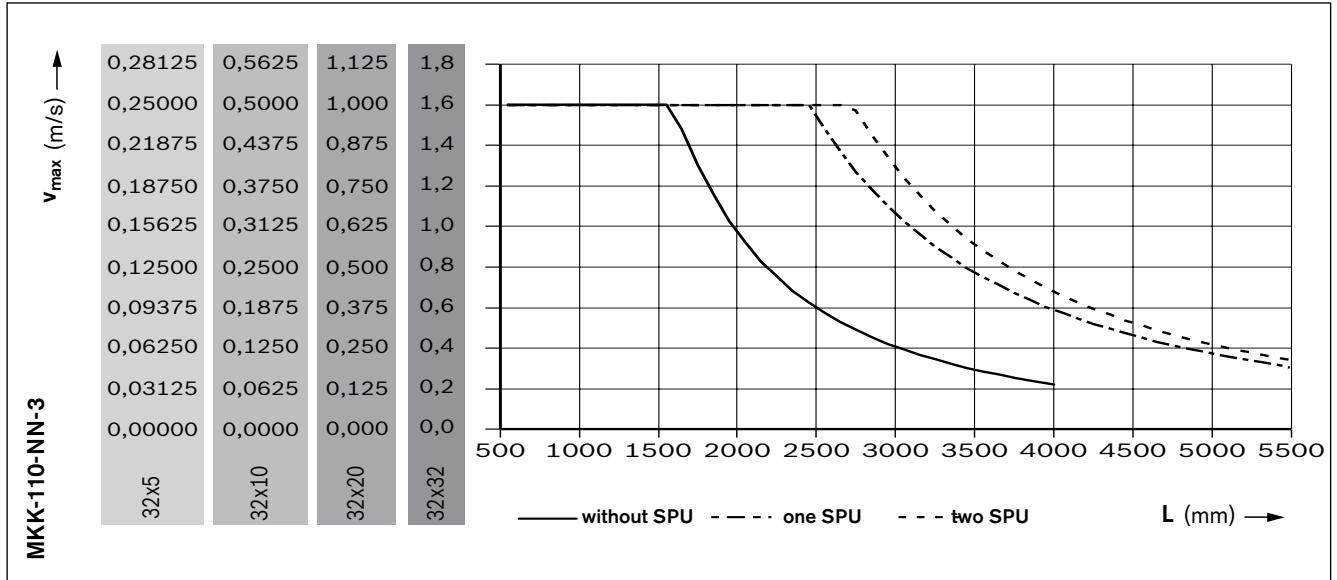

Linear modules MKK

Technical data

Deflection f

Observe the "General technical instructions" chapter

Example:

The graphs apply under the following conditions:

- both ends firmly fixed (200 to 250 mm per side)
- 6 to 8 screws per side fixed substructure
- Observe L_{max} ; see general technical data

Linear module MKK-080: $L = 3000$ mm, $F = 1500$ N

From chart MKK-080: $f = 1.8$ mm $f_{max} = 3.5$ mm

The deflection f lies well below the maximum permissible deflection f_{max} , so no additional supports are required.

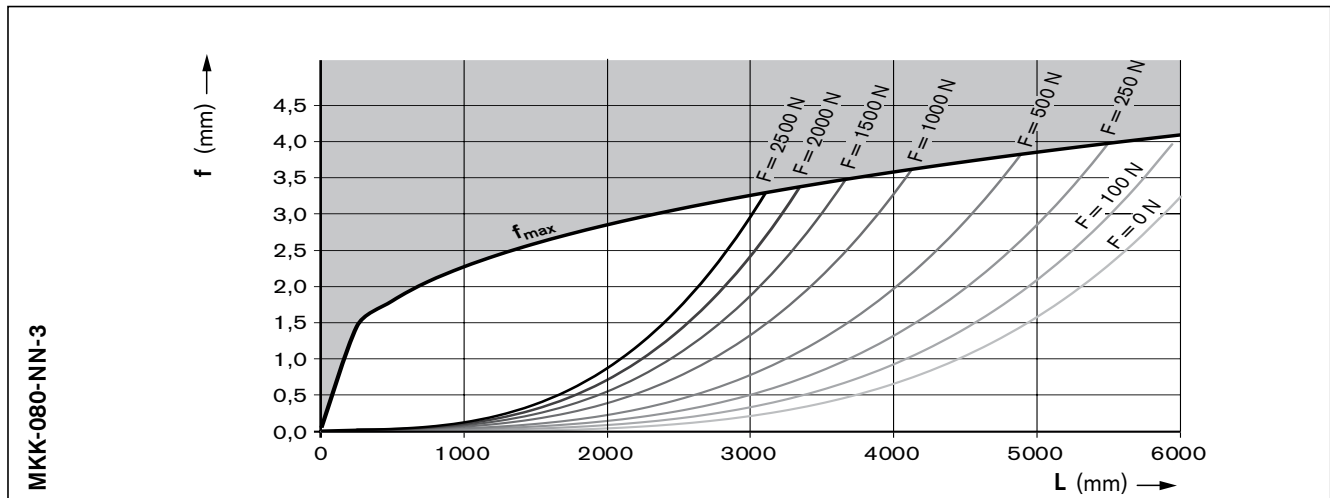
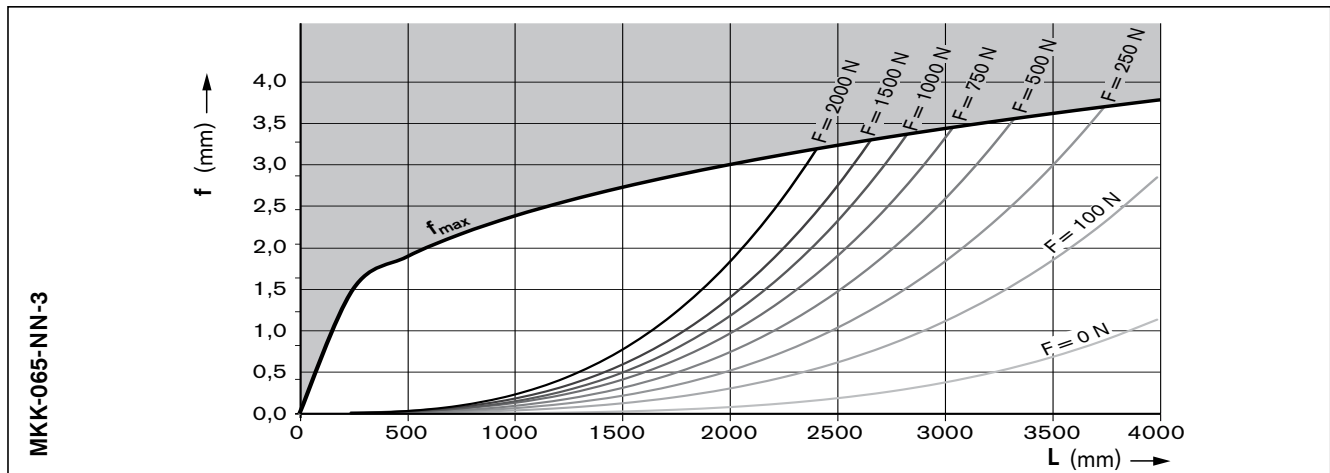
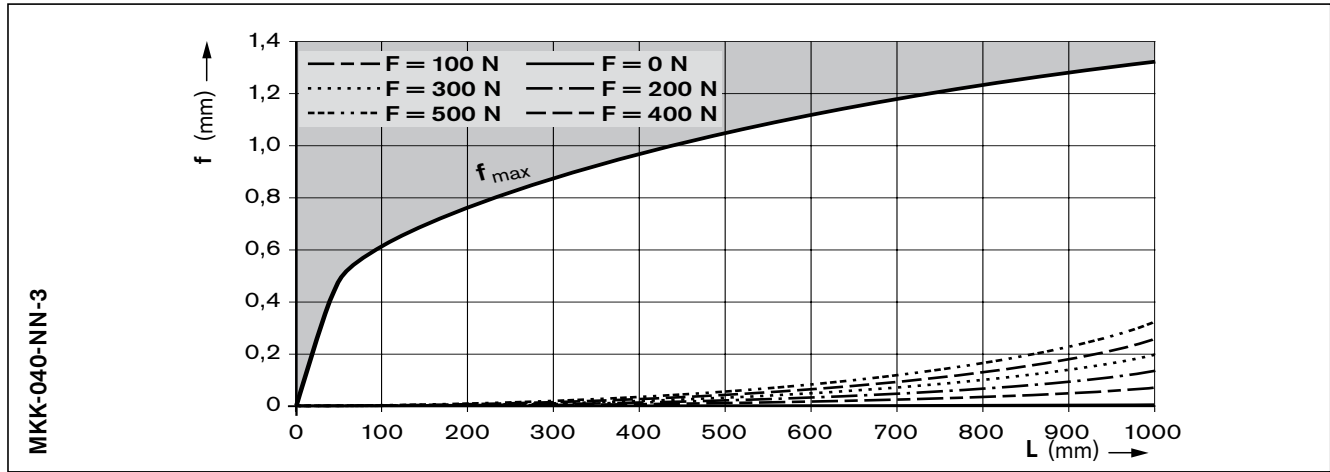

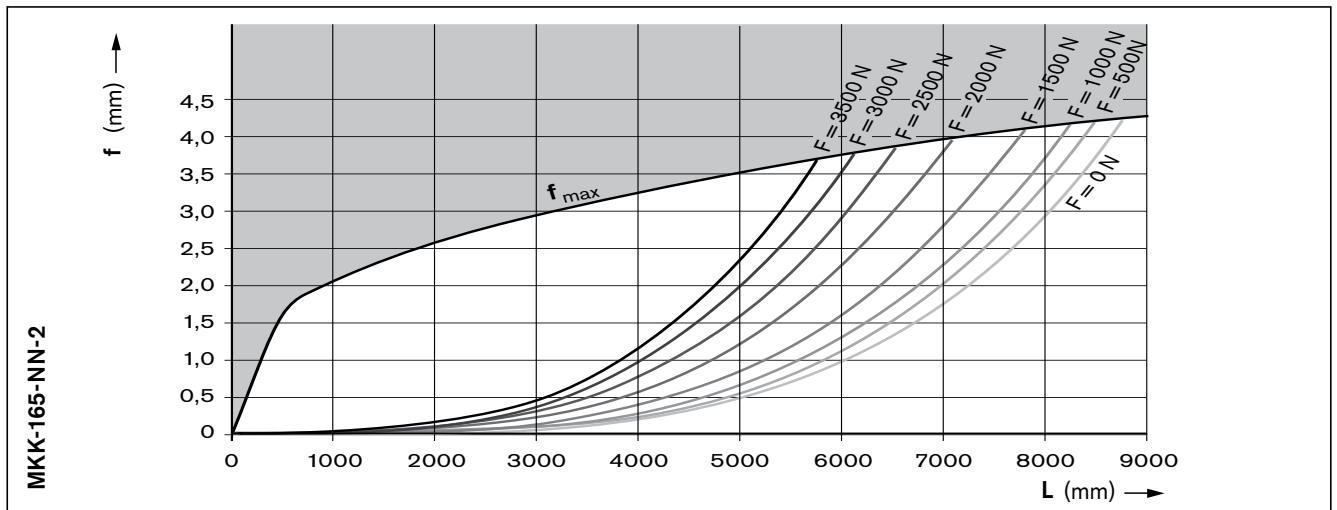
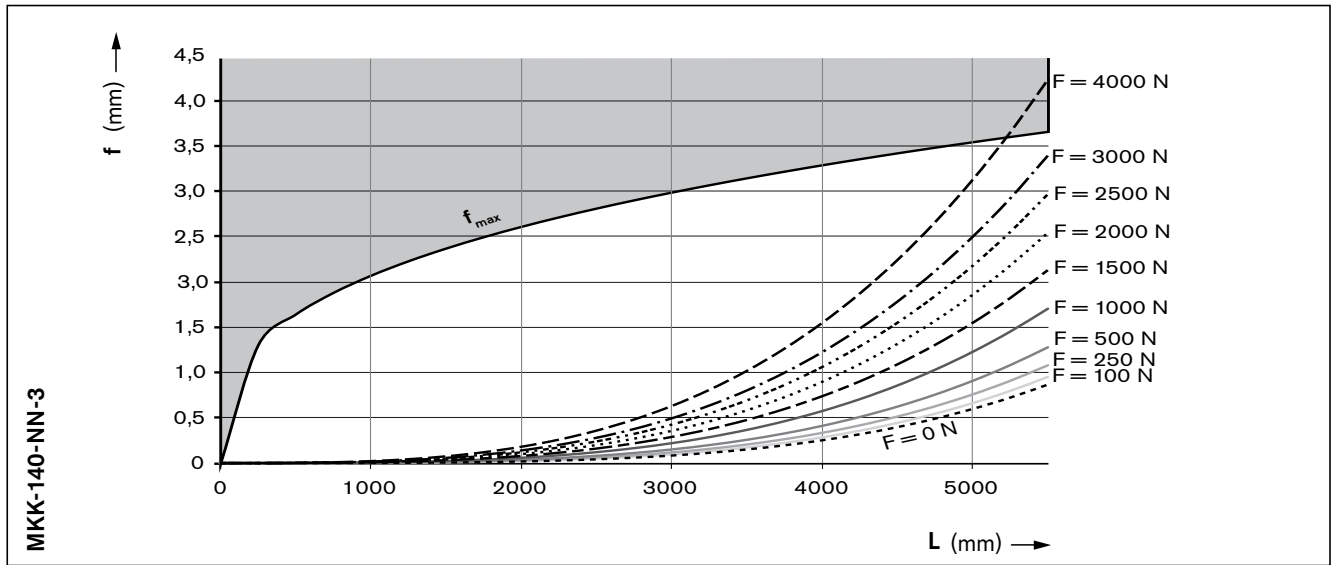
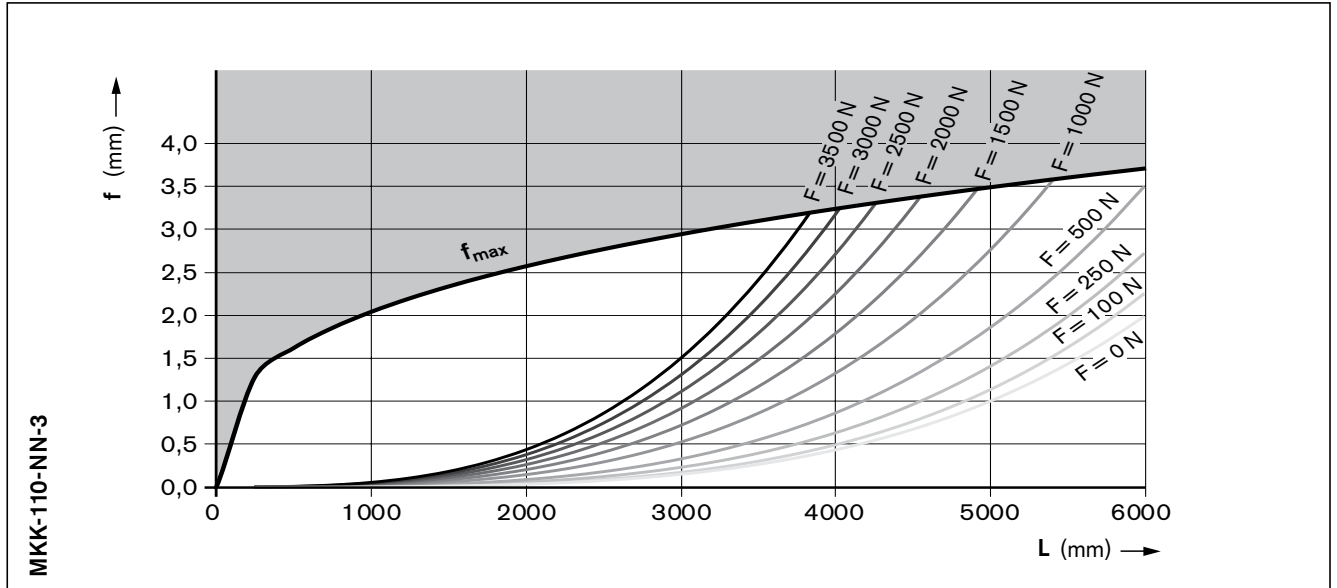



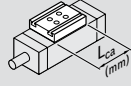

Linear modules MKK

MKK-040-NN-3

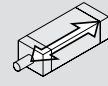
Configuration and ordering

S _{max} ¹⁾ (mm)	Material pairing ²⁾	Lubrication ³⁾ 	Carriage ⁴⁾ 		Guideway 	Drive 	
			Thread (T) L _{ca} = 135 mm	Number TT		Frame with or without center holes	Rexroth ball screw assembly
S _{max} =	ALST (Aluminum/steel)	LSS	T	1	001 without	12x2	T5
		LCF				12x5	T7
		LCO			004 with	12x2	T5
		LPG				12x5	T7
						12x10	
	ALCR (Aluminum/hard chrome plated steel)	LSS	T	1	001 without	12x5	T7
		LCF					
		LCO			004 with	12x10	
LPG							

- 1) Travel distance S_{max} depends on length L and option selection Length calculation \Rightarrow "Project planning/calculation" chapter
- 2) Material pairing \Rightarrow Chapter "Product description MKK-xxx-NN-3".
- 3) Lubrication \Rightarrow see chapter "Additional Information".
- 4) Center holes for simple combination with other linear motion systems and connection elements (see dimensional drawings).
Option 004: with center holes and long hole in the ground area of the frame from travel distance S_{min} \geq 140 mm.
- 5) Attachment kit also available without motor.
Mounting kits according to customer specification \Rightarrow see chapter "Mounting kits for motors according to customer specification".
- 6) Further switch mounting options \Rightarrow see chapter "Switching system".

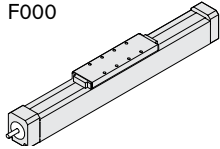
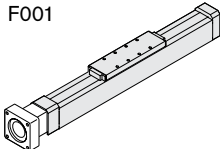
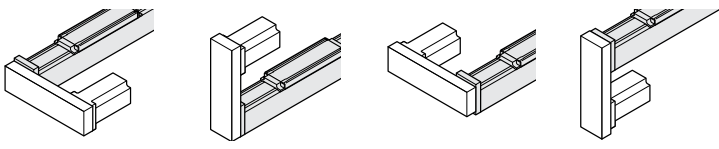
Version	Mounting interface ⁵⁾		Motor						Cover		Sensor system ⁶⁾	Documen- tation
	Gear ratio	Mechanical interface	Motor code	Con- nector		Holding brake		Motor connector position	Cover	Side sealing	Quantity: 1-6	
												
F000 (without flange)	-	-	-	-	-	-	-	-	0 without	0 without		
												
F001 (with flange)	i = 1	MS2N03-B MSM019B MSM031B	MS2N03-B0BYN MSM019B-0300 MSM031B-0300	1 - -	2 2 2		Y	N	000 090 180 270			
												
S000 S090 S180 S270 (with timing belt side drive)	i = 1 i = 1.5	MS2N03-B MSM019B MSM031B MS2N03-B MSM019B MSM031B	MS2N03-B0BYN MSM019B-0300 MSM031B-0300 MS2N03-B0BYN MSM019B-0300 MSM031B-0300	1 - - 1 - -	2 2 2 2 2 2		Y	N	000 090 180 270	2 with	0 without	

Flange	Motor connector position			
	0°	90°	180°	270°
F001	000	090 ★	180	270

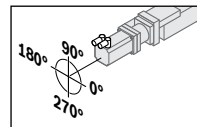

Example:
Flange F001
Motor connector position 90°

Timing belt side drive	Motor connector position			
	0°	90°	180°	270°
S000	-	090	180 ★	270
S090	000	090 ★	180	-
S180	000 ★	090	-	270
S270	000	-	180	270 ★

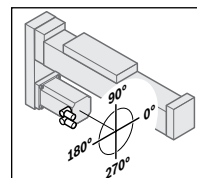

Example:
Timing belt side drive S270
Motor connector position 180°

★ Standard delivery (connector position)

Linear modules MKK

MKK-065-NN-3

Configuration and ordering

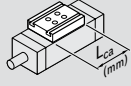
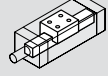
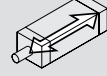
s _{max.} ¹⁾ (mm)	Material pairing ²⁾	Lubrication ³⁾ 	Carriage (TT) 		L _w (mm) (2 TT only)	Guideway 	Drive ⁴⁾ 		
			T-slot (S) Thread (T) L _{ca} = 190 mm	Number TT			Frame with or without center holes	Keyway	Rexroth ball screw assembly
s _{max} =	ALST (Aluminum/steel)	LSS	S	2	L _w =	001 without	0 without	16x5	T5
			T					16x10	
			S	1				16x16	T7
			T					16x5	
		LCF	S	1	-	004 with	1 with	16x5	T7
			T					16x10	
16x16									
ALCR (Aluminum/hard chrome plated steel)	LSS	S	1	-	011 without	0 without	16x5	T7	
							16x10		
		T	16x16						
			014 with						

1) Travel distance s_{max} depends on length L and option selection Length calculation ➡ "Project planning/calculation" chapter
 2) Material pairing ➡ Chapter "Product description MKK-xxx-NN-3".
 3) Lubrication ➡ see chapter "Additional Information".
 4) Drive journal with keyway only available with F000 version!
 5) Attachment kit also available without motor.
 Mounting kits according to customer specification ➡ see chapter "Mounting kits for motors according to customer specification".
 6) Further switch mounting options ➡ see chapter "Switching system".

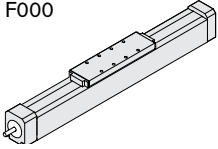
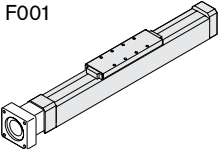
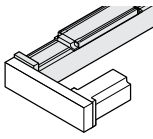
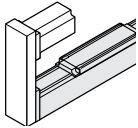
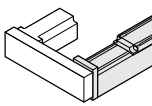
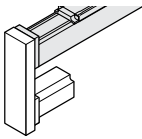
Version	Mounting interface ⁵⁾		Motor	Motor connector				Holding brake	Motor connector position	Cover	Sensor system ⁶⁾		Documentation			
	Gear ratio	Mechanical interface		1 cable	2 cable	with	without				Cover	Side sealing		Quantity: 1-6		
<div style="text-align: center;">  <p>F000</p> </div>																
F000 (without flange)	-	-	-	-	-	-	-	-	0 without	0 without	000 without switch 120 sensor, PNP / normally closed (NC) 121 sensor NPN / normally closed (NC) 122 sensor, M8x1, PNP / normally open (NO) 123 sensor, M8x1, NPN / normally open (NO)					
<div style="text-align: center;">  <p>F001</p> </div>																
F001 (with flange)	i = 1	MS2N04	MS2N04-C0BTN	1	2	Y	N	000	2 with	0 without			001 standard; 002 frictional torque 003 lead deviation; 005 positioning accuracy			
		MSM041	MSM041B-0300	-	2			090								
<div style="display: flex; justify-content: space-around;"> <div style="text-align: center;">  <p>S000</p> </div> <div style="text-align: center;">  <p>S090</p> </div> <div style="text-align: center;">  <p>S180</p> </div> <div style="text-align: center;">  <p>S270</p> </div> </div>																
S000 S090 S180 S270 (with timing belt side drive)	i = 1.5	MS2N04	MS2N04-B0BTN	1	2	Y	N	000			1 with					
		MSM041	MSM041B-0300	-	2			090								
		MS2N04	MS2N04-B0BTN	1	2			180								
		MSM041	MSM041B-0300	-	2			270								

Flange	Motor connector position			
	0°	90°	180°	270°
F001	000	090 ★	180	270

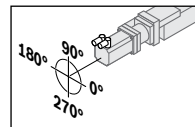

Example:
Flange F001
Motor connector position 90°

Timing belt side drive	Motor connector position			
	0°	90°	180°	270°
S000	-	090	180 ★	270
S090	000	090 ★	180	-
S180	000 ★	090	-	270
S270	000	-	180	270 ★

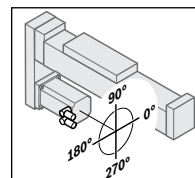





Example:
Timing belt side drive S270
Motor connector position 180°

★ Standard delivery (connector position)

Linear modules MKK

MKK-080-NN-3

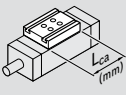
Configuration and ordering

s _{max} ¹⁾ (mm)	Material pairing ²⁾	Lubrication ³⁾ 	Measuring system IMS- A ⁴⁾ 	Carriage ⁵⁾⁶⁾ (TT) 		L _w (mm) (2 TT only)	Guideway 	Drive ⁸⁾⁹⁾ 			SPU ⁹⁾¹⁰⁾		
				T-slot (S) Thread (T) L _{ca} = 260 mm ⁷⁾	Number TT			Frame with or without center holes	Keyway	Rexroth ball screw assembly		Tolerance grade	
s _{max} =	ALST (Aluminum/steel)	LSS	001 (HF)	S	1	-	104 with	0 without	20x5	T5	010 without SPU		
			002 (DQ)	T	1	-			20x10				
			000 without	S	2	L _w =			20x20				
		LCF	S	1	001 without	20x40							
			T	1		T7							
			-	S			1	20x5					
	LCO	-	S	1	-		004 with	1 with	20x10	T7			
		LPG	T	1	20x20								
			-	T	1	20x40							
	ALCR (Aluminum/hard chrome plated steel)	LSS	-	-	S	1	-	011 without	0 without	20x5		T7	002 with SPU (2 pair)
					LCF	S	1	-		20x10			
					LCO	T	1	-		20x20			
LPG					T	1	-	20x40					

- 1) Travel distance s_{max} depends on length L and option selection Length calculation ➡ "Project planning/calculation" chapter
- 2) Material pairing ➡ Chapter "Product description MKK-xxx-NN-3".
- 3) Lubrication ➡ see chapter "Additional Information".
- 4) No SPU available for version with IMS. IMS measuring system not available with Rexroth ball screw assembly 20x40.
- 5) Carriage version "2 TT" optionally available without screw support (SPU).
- 6) Thread (T) carriage version not available with Rexroth ball screw assembly 20x40.
- 7) Carriage with measuring system, L_{ca} = 360 mm
- 8) Drive journal with keyway only available with F000 version!
- 9) SPU only possible for carriage version "1 TT"!
- 10) No screw support is available for Rexroth ball screw assembly 20x40.
- 11) Attachment kit also available without motor.
- ➡ Mounting kits according to customer specification ➡ see chapter "Mounting kits for motors according to customer specification".
- 12) Further switch mounting options ➡ see chapter "Switching system".

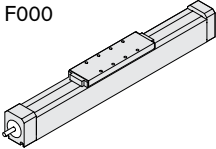
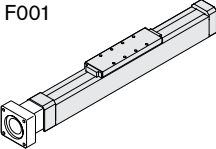
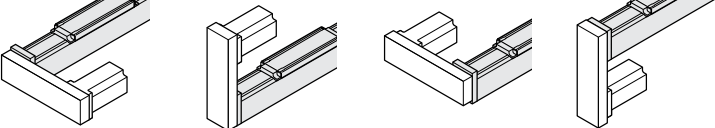
Version	Attachment interface ¹¹⁾		Motor					Cover		Sensor system ¹²⁾	Documen- tation					
	Gear ratio	Mechanical interface	Motor code	Con- nec- tor		Holding brake		Motor connector position	Cover	Side sealing	Quantity: 1-6					
																
F000 (without flange)	-	-	-	-	-	-	-	-	0 without	0 without						
																
F001 (with flange)	i = 1	MS2N04	MS2N04-B0BTN	1	2	Y	N	000 090 180 270	2 with	0 without	000 without sensor 120 sensor (PNP NC); 121 sensor (NPN NC) 122 sensor (PNP NO); 123 sensor (NPN NO)	001 standard; 002 frictional torque 003 lead deviation; 005 positioning accuracy				
			MS2N04-C0BTN													
		MS2N04-D0BQN														
		MSM041	MSM041B-0300	-	2											
			MS2N05	MS2N05-B0BTN	1								2			
MS2N05-C0BTN																
																
S000 S090 S180 S270 (with timing belt side drive)	i = 1	MS2N05	MS2N05-C0BTN	1	2	Y	N	000 090 180 270					2 with	1 with		
			MS2N05-D0BRN													
		MS2N04	MS2N04-C0BTN	1	2											
			MS2N04-D0BQN													
	i = 1.5	MS2N04	MS2N04-B0BTN	1	2											
			MS2N04-C0BTN													
		MSM041	MSM041B-0300	-	2											
			MS2N05	MS2N05-B0BTN	1				2							

Flange	Motor connector position			
	0°	90°	180°	270°
F001	000	090 ★	180	270

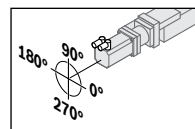

Example:
Flange F001
Motor connector position 90°

Timing belt side drive	Motor connector position			
	0°	90°	180°	270°
S000	-	090	180 ★	270
S090	000	090 ★	180	-
S180	000 ★	090	-	270
S270	000	-	180	270 ★

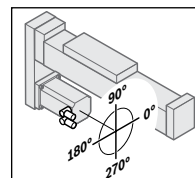





Example:
Timing belt side drive S270
Motor connector position 180°

★ Standard delivery (connector position)

Linear modules MKK

MKK-110-NN-3

Configuration and ordering

s _{max} ¹⁾ (mm)	Material pairing ²⁾	Lubrication ³⁾ 	Measuring system IMS- A ⁴⁾ 	Carriage ⁵⁾ (TT)		L _w (mm)	Guideway 	Drive ⁷⁾ 			SPU ⁸⁾
				T-slot (S) Thread (T) L _{ca} = 305 mm ⁶⁾	Number TT			Frame with or without center holes	Keyway	Rexroth ball screw assembly	
s _{max} =	ALST (Aluminum/steel)	LSS	001 (HF)	S	1	-	104 with	0 without	32x5	T5	010 without screw support
			002 (DQ)	T							
		000 without	S	2	L _w =	001 without	32x10	T7			
			T				32x20				
		LCF	S	1	-	004 with	32x5	T7			
			LCO				-		32x10		
	LPG	T			32x20						
					32x32						
	ALCR (Aluminum/hard chrome plated steel)	LSS	S	1	-	011 without	32x5	0 without	T7		
		LCF					32x10				
		LCO	-			32x20					
		LPG	T			014 with	32x32				
							002 with screw support (2 pair)				

¹⁾ Travel distance s_{max} depends on length L and option selection Length calculation → "Project planning/calculation" chapter

²⁾ Material pairing → Chapter "Product description MKK-xxx-NN-3".

³⁾ Lubrication → see chapter "Additional Information".

⁴⁾ No SPU available for version with IMS

⁵⁾ Carriage version "2 TT" optionally available without screw support (SPU).

⁶⁾ Carriage with measuring system, L_{ca} = 430 mm







































































































































































































































⁷⁾ Drive journal with keyway only available with F000 version!

⁸⁾ SPU only possible for carriage version "1 TT"!

⁹⁾ Attachment kit also available without motor.

Mounting kits according to customer specification → see chapter "Mounting kits for motors according to customer specification".





¹⁰⁾ Further switch mounting options → see chapter "Switching system".

Version	Mounting interface ⁹⁾		Motor						Cover		Sensor system ¹⁰⁾	Documenta- tion
	Gear ratio	Mechanical interface	Motor code	Connector		Holding brake		Motor connector position	Cover	Side sealing	Quantity: 1-6	
				1 cable	2 cable	with	without					
												
												
												
												
												
												
												
												
												
												
												
												
												
												
												
												
												
												
												
												
												
												
												
												
												
												
												
												
												
												
												
												
												
												
												
												
												
												
												
												
												
												
												
												
												
												
												
												
												
												
												
												
												
												
												
												
												
												
												
												
												
												
												
												
												
												
												
												
												
												
												
												
												
												
												
												
												
												
												
												
												
												
												
												
												
												
												
												
												
												
												
												
												
												
												
												
												
												
												
												
												
												
												
												
												
												
												
												
												
												
												
												
												
												
												
												
												
												
												
												
												
												
												
												
												
												
												
												
												
												
												
												
												
												
												
												
												
												
												
												
												
												
												
												
												
												
												
												
												
												
												
												
												
												
												
												
												
												
												
												
												
												
												
												
												
												
												
												
												
												
												
												
												
												
												
												
												
												
												
												
												
												
												
												
												
												
												
												
												
												
												
												
												
												
												
												
												
												
												
												
												
												
												
												
												
												
												
												
												
												
												
												
												
												
												
												
												
												
												
												
												
												
												
												
												
												
												
												
												





Linear modules MKK

MKK-140-NN-3

Configuration and ordering

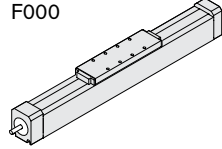
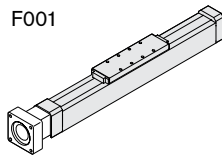
S _{max} ¹⁾ (mm)	Material pairing ²⁾	Lubrication ³⁾ 	Measuring system IMS- A ⁴⁾ 	Carriage ⁵⁾ (TT)		L _w (mm) (2 TT only)	Guideway  Frame with or without center holes	Drive ⁷⁾ 			SPU ⁸⁾								
				T-slot (S) Thread (T) L _{ca} = 370 mm ⁶⁾	Number TT			Keyway	Rexroth ball screw assembly	Tolerance grade									
S _{max} =	ALST (Aluminum/steel)	LSS	001 (HF)	S	1	-	104 with	0 without	40x5	T5	010 without screw support								
			002 (DQ)	T															
			000 without	S	2		L _w =					001 without	40x10						
				T									40x20						
		LCF	S	1	-	004 with	40x40		T7										
			LCO				-			40x5									
			LPG				T			40x10									
			40x20																
	ALCR (Aluminum/hard chrome plated steel)	LSS	-	-	S	1	-	0 without	40x5	T7		002 with screw support (2 pair)							
													LCF	-	-	S	1	-	40x10
																			LCO
													LPG	T	40x40				

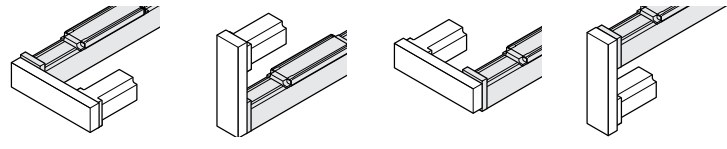
1) Travel distance s_{max} depends on length L and option selection Length calculation ➡ "Project planning/calculation" chapter
 2) Material pairing ➡ Chapter "Product description MKK-xxx-NN-3".
 3) Lubrication ➡ see chapter "Additional Information".
 4) No SPU available for version with IMS
 5) Carriage version "2 TT" optionally available without screw support (SPU).
 6) Carriage with measuring system, L_{ca} = 500 mm
 7) Drive journal with keyway only available with F000 version!
 8) SPU only possible for carriage version "1 TT"!
 9) Attachment kit also available without motor.
 Mounting kits according to customer specification ➡ see chapter "Mounting kits for motors according to customer specification".
 10) Further switch mounting options ➡ see chapter "Switching system".

Version	Mounting interface ⁹⁾		Motor						Cover		Sensor system ¹⁰⁾	Documen- tation
	Gear ratio	Mechanical interface	Motor code	Con- nec- tor		Holding brake		Motor connector position	Cover	Side sealing	Quantity: 1-6	
			<p>F000</p> 									
F000 (without flange)			-	-	-	-	-	-	0 without	0 without		
			<p>F001</p> 									
F001 (with flange)			i = 1	MS2N07	MS2N07-B1BNN	1	2	Y	N		000	000 without sensor 120 sensor (PNP NC); 121 sensor (NPN NC) 122 sensor (PNP NO); 123 sensor (NPN NO)
					MS2N07-C1BRN						090	
					MS2N07-D1BNN						180	
						270						
			 <p>S000 S090 S180 S270</p>						2 with		0 without	
S000 S090 S180 S270 (with timing belt side drive)			i = 1	MS2N07	MS2N07-B1BNN	1	2	Y	N		000	1 with
					MS2N07-C1BRN						090	
					MS2N07-D1BNN						180	
			i = 2	MS2N07	MS2N07-B1BNN						270	
					MS2N07-C1BRN							
					MS2N07-D1BNN							

Flange	Motor connector position			
	0°	90°	180°	270°
F001	000	090 ★	180	270

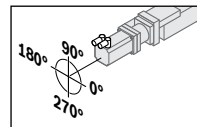

Example:
Flange F001
Motor connector position 90°

Timing belt side drive	Motor connector position			
	0°	90°	180°	270°
S000	-	090	180 ★	270
S090	000	090 ★	180	-
S180	000 ★	090	-	270
S270	000	-	180	270 ★

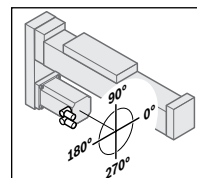

Example:
Timing belt side drive S270
Motor connector position 180°

★ Standard delivery (connector position)

Linear modules MKK

MKK-165-NN-2

Configuration and ordering

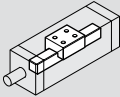
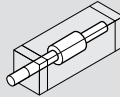
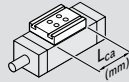
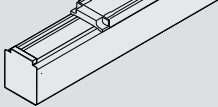
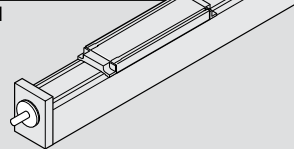
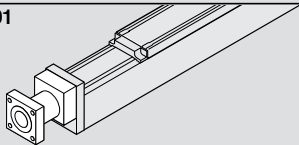
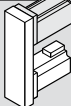
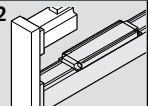
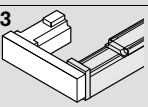
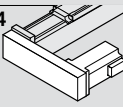
Short product name, length (L) Example: MKK-165-NN-2, (L) mm		Guideway	Drive				Carriage	
Version			Rexroth ball screw assembly size $d_0 \times P$				$L_{ca} = 400 \text{ mm}$ 	
			40x5	40x10	40x20	40x40		
without drive	OA1 	01	00				10	
with Rexroth ball screw assembly, without flange	OF01 	01	$\varnothing 25$	01	02	03	04	01
			$\varnothing 25$ with PF groove	11	12	13	14	
with Rexroth ball screw assembly and flange	MF01 	01	$\varnothing 25$	01	02	03	04	01
with Rexroth ball screw assembly and timing belt side drive	RV01 	01	$\varnothing 25$	01	02	03	04	01
	RV02 							
	RV03 							
	RV04 							

1) Flange and coupling or timing belt side drive for motor type according to customer specification, ➡ see chapter "Mounting kits for motors according to customer specification".

2) Attachment kit also available without motor (when ordering: enter "00" for motor)

Length calculation ➡ "Project planning/calculation" chapter

Gear ratio i =	Attachment kit ²⁾	Motor code	2 cable Brake		1 cable Brake		Motor connector position	Cover		Switches / Mounting channel / Socket-plug	Documentation
			without	with	without	with		Without PU bellows	with		
-	00	-	-	-	-	-	-	00	01	Without switch and mounting channel 00 Switches: - PNP NC 11 - PNP NO 13 - Mechanical 15	001 standard; 002 frictional torque 003 lead deviation; 005 positioning accuracy
-	00	-	-	-	-	-	-	00	01		
1	003	MS2N07-C0BQN	257	258	259	260	000	00	01	Cable channel (loose) 20	
		MS2N07-C1BRN	261	262	263	264					
		MS2N07-D0BRN	265	266	-	-					
		MS2N07-E0BQN	271	272	-	-					
1	025	MS2N07-C1BRN	261	262	263	264	090	00	01	Socket-plug external floating 17	
		MS2N07-D0BRN	265	266	-	-					
		MS2N07-E0BQN	271	272	-	-					
2	026	MS2N07-C0BQN	257	258	259	260	270	00	01	External switching cam 16	
		MS2N07-C1BRN	261	262	263	264					
		MS2N07-D0BRN	265	266	-	-					

Flange	Motor connector position			
	0°	90°	180°	270°
MF01	000	090 ★	180	270

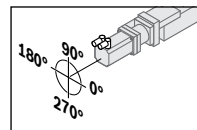

Example:
Flange MF01
Motor connector position 90°

Timing belt side drive	Motor connector position			
	0°	90°	180°	270°
RV01	-	090	180 ★	270
RV02	000	090 ★	180	-
RV03	000 ★	090	-	270
RV04	000	-	180	270 ★

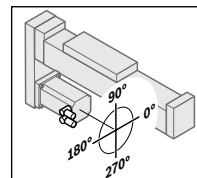

Example:
Timing belt side drive RV01
Motor connector position 180°

★ Standard delivery (connector position)

Dimensional drawings MKK-040/-065/-080/-110/-140/-NN-3 Frame

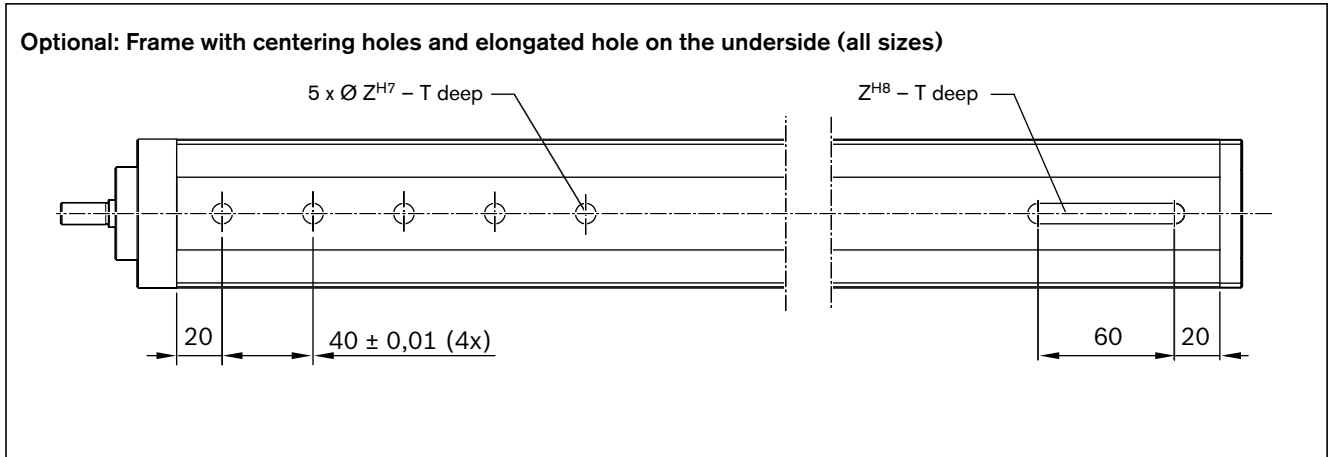
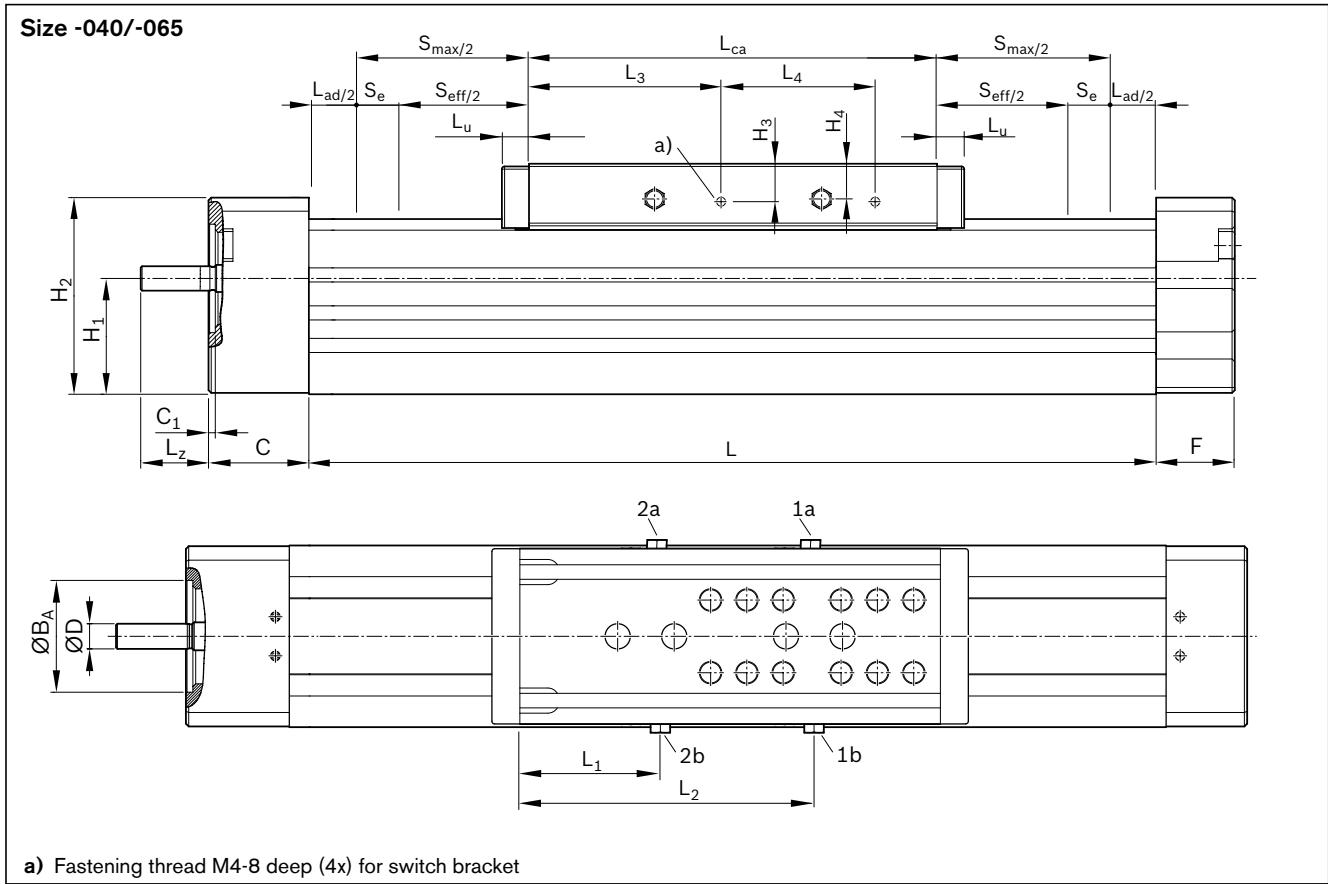

MKK	Dimensions (mm)																			
	B	B _S	$\varnothing B_A$ H7/h7	C	C ₁	$\varnothing D$ h7	E ₁	E ₂	F	H	H ₁	H ₂	H ₃	H ₄	L ₁	L ₂	L ₃	L ₄	L _{ca}	L _u
-040-NN-3	40	-	28	25	2.5	6	23	33	17	52	25.0	48.0	3.7	8.0	75.0	86.85	20.0	27	135	6.5
-065-NN-3	65	-	40	37	2.5	9	28	40	29	85	42.7	72.5	14.0	13.0	59.5	134.25	84.0	70	190	10.0
-080-NN-3	80	-	55	29	13.0	10	50	66	13	100	57.5	100.0	12.0	12.7	76.5 ¹⁾	175.00	88.0	70	260	30.0
-110-NN-3	110	85	68	29	16.0	16	46	90	16	129	78.0	133.0	16.0	16.0	120.5	224.60	137.5	70	305	35.0
-140-NN-3	140	105	80	63	4.0	25	65	100	14	170	98.5	161.0	19.0	23.0	141.0	266.70	35.0	70	370	35.0

L_{ad} = additional length → Chapter "Technical data"

¹⁾ bei BASA 20 x 40: Maß $L_1 = 70$

See following pages for dimension drawings for carriages and motor attachment.

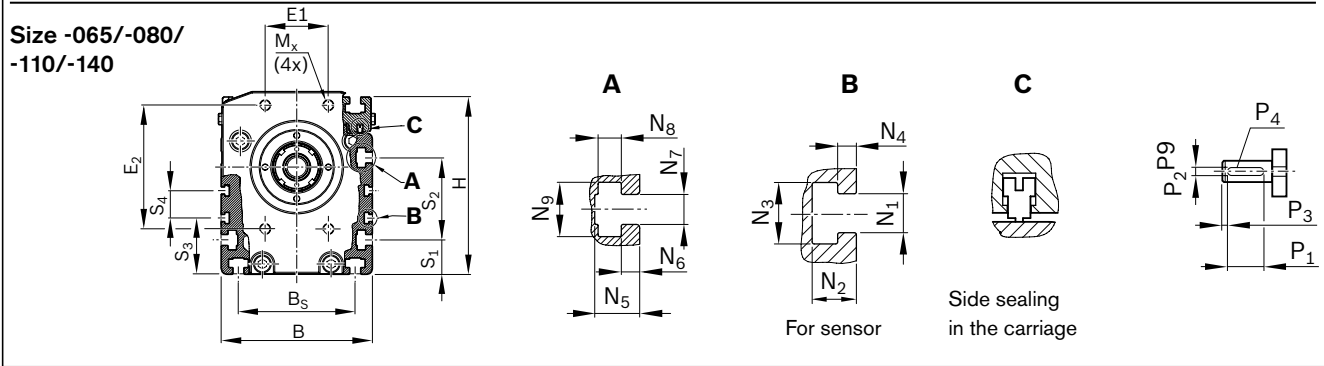
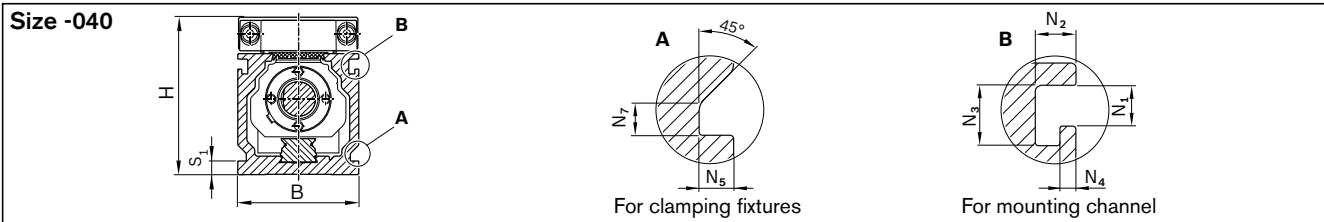
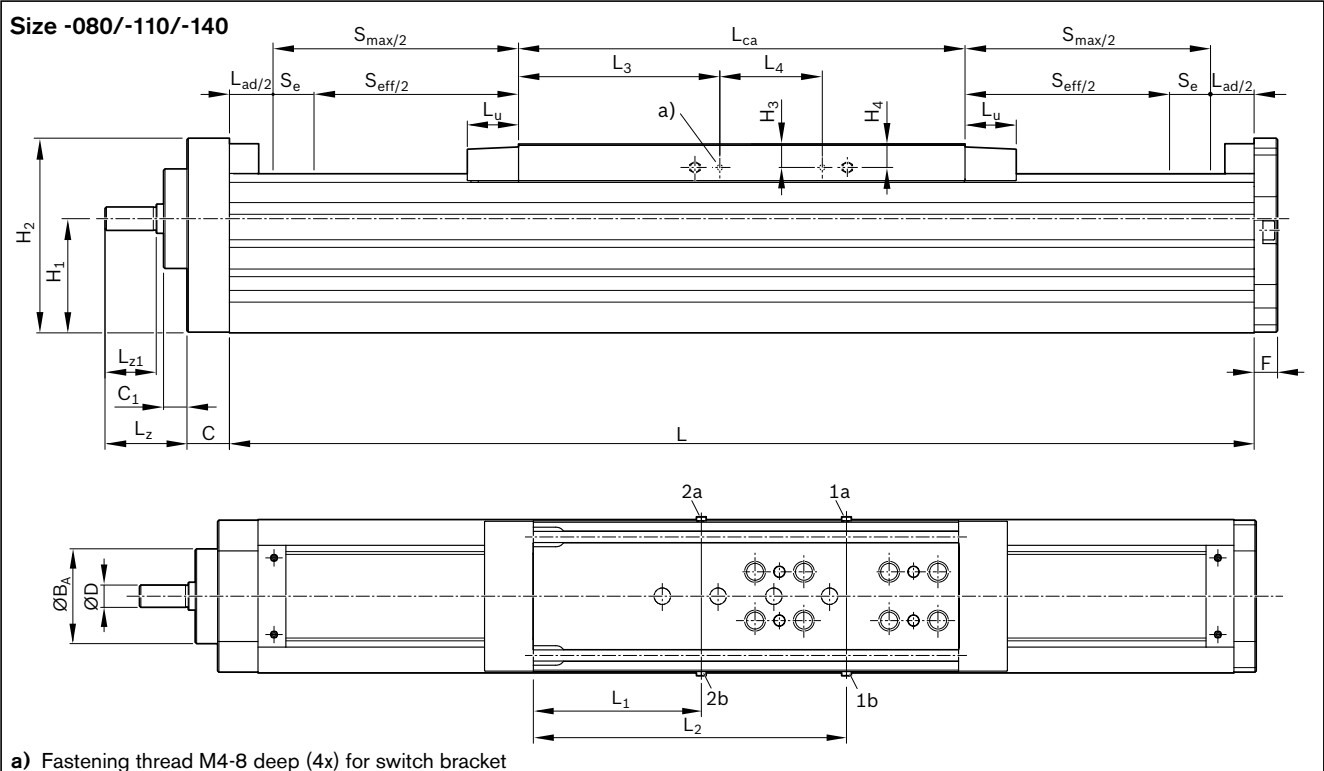

L_z	L_{z1}	M_x	Sliding block	N_1	N_2	N_3	N_4	N_5	N_6	N_7	N_8	N_9	P_1	P_2	P_3	P_4 deep	S_1	S_2	S_3	S_4	T	Z
18	-	M4-8 deep	-	3.3	3.3	4.9	1.3	2.8	-	2.5	-	-	-	-	-	4.5	-	36.5	-	1.6	7	
25	-	M6-14 deep	DIN557-M5	5.2	5.9	8.2	2.5	8.5	2.5	5.2	5.0	9.0	20	3	2.5	1.8	18.0	26	30.0	-	2.1	9
40	27	M8-18 deep	DIN557-M5	5.2	5.9	8.2	2.5	8.5	2.5	5.2	5.0	9.0	20	3	2.5	1.8	18.0	45	31.0	-	2.1	9
56	35	M8-18 deep	DIN508-M6	5.2	5.9	8.2	2.5	12.0	4.9	8.0	6.2	14.5	28	5	3.5	3.0	25.0	60	41.0	20	2.1	12
73	69	M10-20 deep	DIN508-M8	5.2	5.9	8.2	2.5	15.0	7.0	10.0	7.0	17.0	40	8	5.0	4.0	37.5	70	57.0	68	3.1	16

1a / 1b lube connection for ball runner block: lubrication on either of the two connections.
 2a / 2b lube connection for Rexroth ball screw assembly: lubrication on either of the two connections.
 (Lube connection 1a / 1b / 2a / 2b: funnel-type lube nipple DIN 3405-A M6; Size -040: DIN 3405-A M3)
 For further information, see the section titled "Lubrication".

MKK-040/-065/-080/-110/-140/-NN-3 Carriage dimension drawings

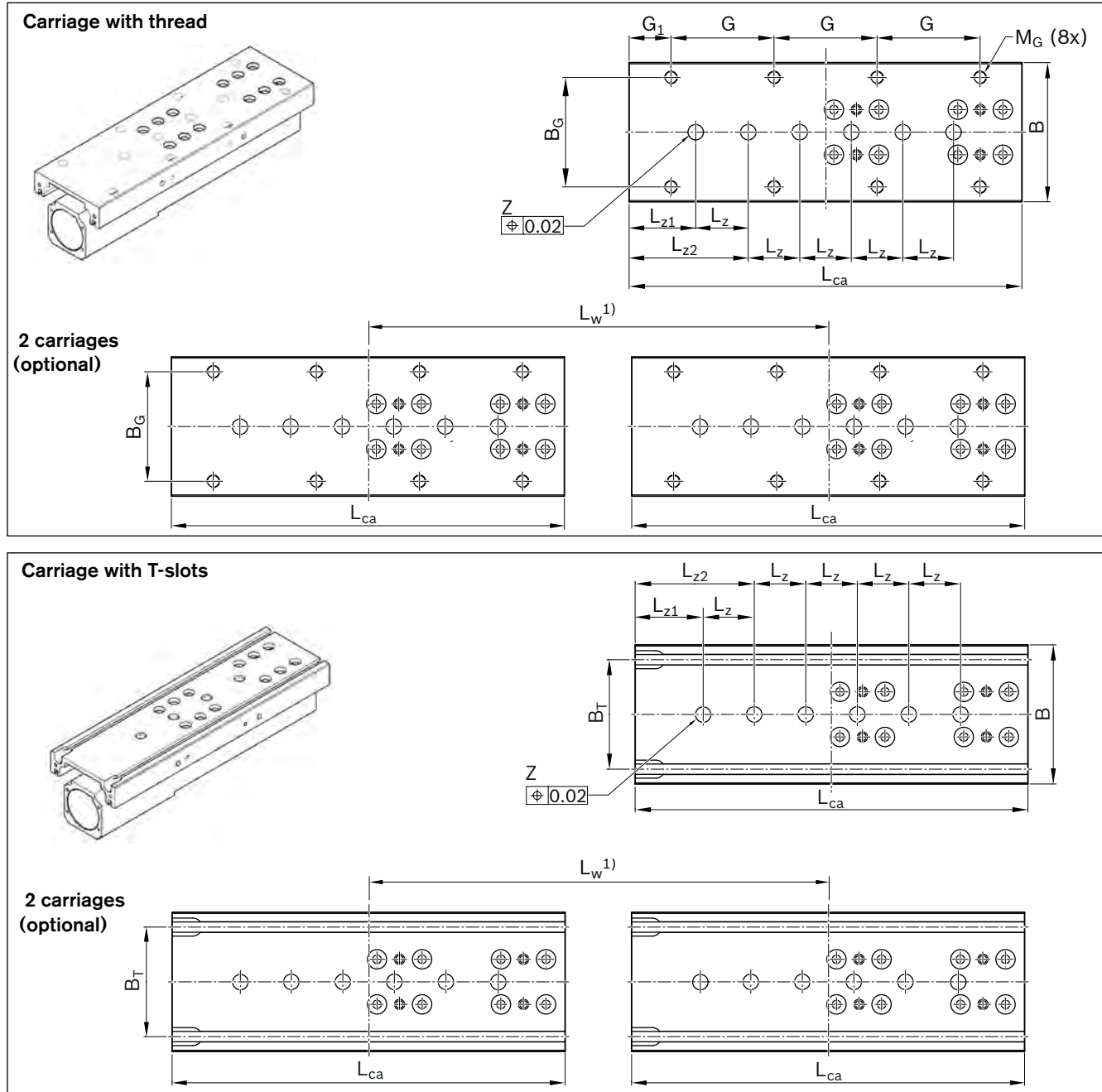

MKK	Dimensions (mm)														
	B	B _G	B _{IMS}	B _T	G	G ₁	H _{IMS}	L _{ca}	L _{ca} IMS ²⁾	L _w min	L _w max	L _z	L _{z1}	L _{z2}	M _G
-040-NN-3	39.5	30	-	-	25	30.0	-	135	-	-	-	20	-	37.5	M4-9 deep
-065-NN-3	63.0	46	-	46	50	20.0	-	190	-	210	750	40	-	35.0	M6-9 deep
-080-NN-3	78.0	60	126	60	70	25.0	6.5	260	360	320	960	40	-	70.0	M8-10 deep
-110-NN-3	108.0	85	156	85	80	32.5	8.0	305	430	375	1095	40	-	92.5	M10-12 deep
-140-NN-3	138.0	105	186	105	105	27.5	11.0	370	500	450	1350	40	85	-	M10-20 deep

¹⁾ Variable centerline-to-centerline distance defined by customer-built mounting base.
 Centerline-to-centerline distance freely selectable between minimum and maximum distance in millimeters steps.
²⁾ Clamping surface corresponds to L_{ca}
³⁾ Non-usable clamping surface

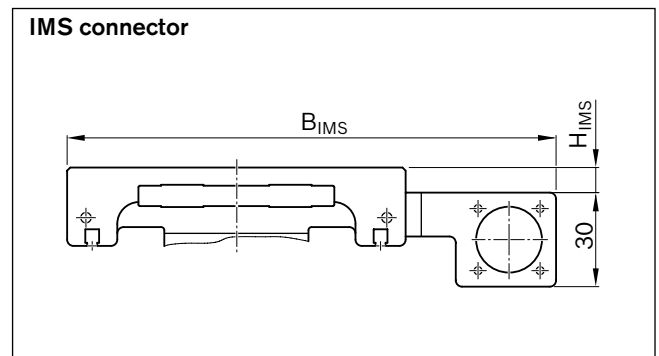
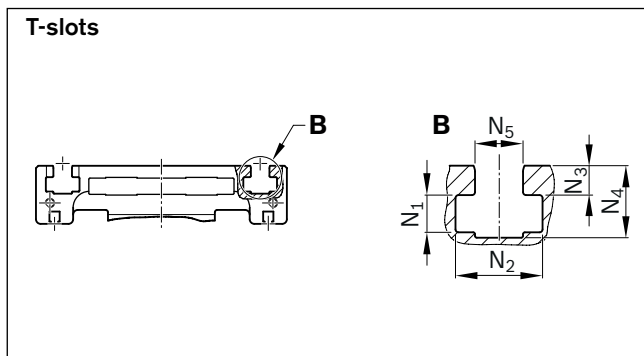
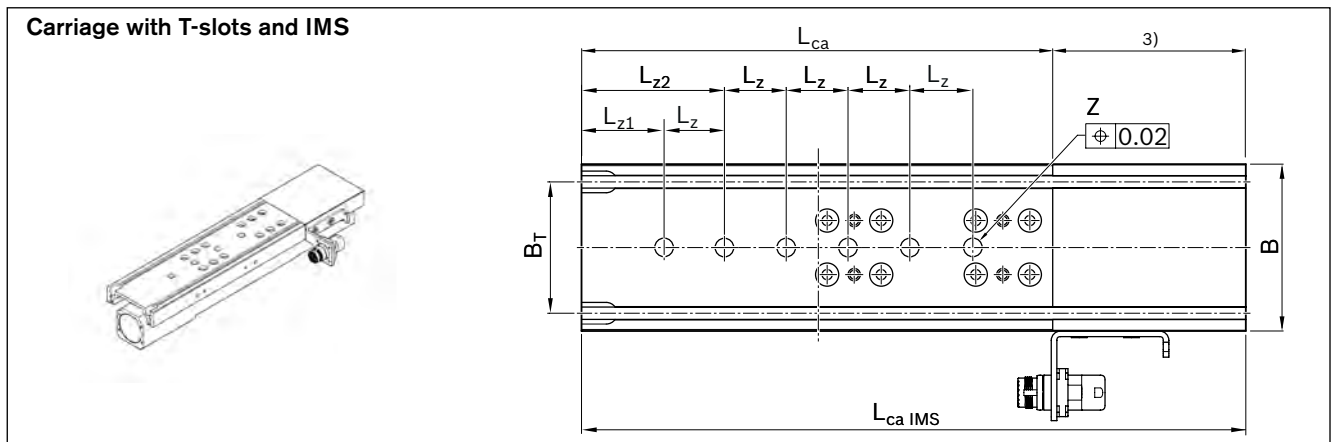
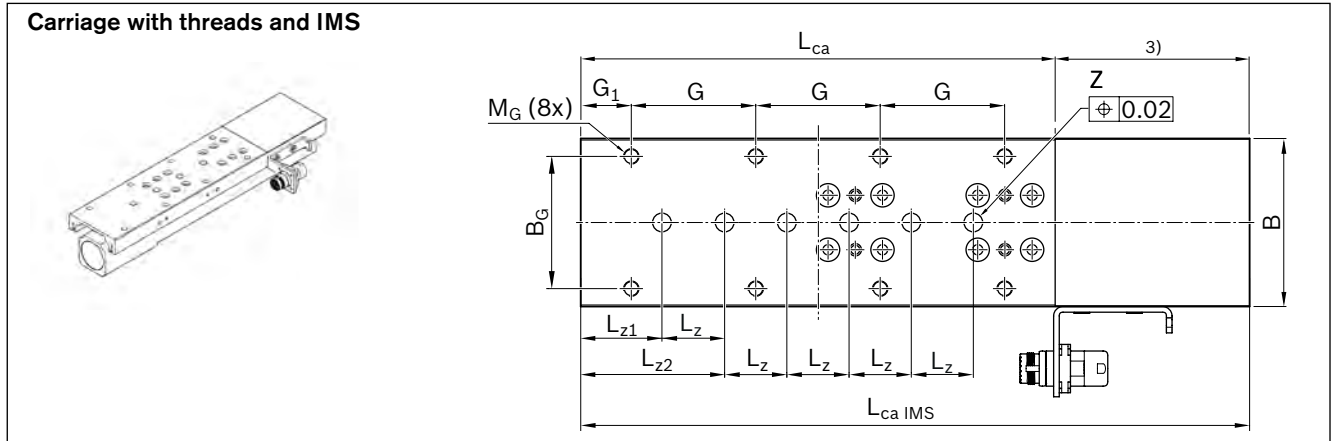

Sliding block	N_1	N_2	N_3	N_4	N_5	Z
-	-	-	-	-	-	4 x \varnothing 7H7-1.6 deep
DIN557-M5	5.0	9.0	2.5	8.5	5.2	4 x \varnothing 9H7-2.1 deep
DIN557-M5	5.0	9.0	2.5	8.5	5.2	4 x \varnothing 9H7-2.1 deep
DIN508-M6	6.2	14.5	4.9	12.0	8.0	4 x \varnothing 12H7-2.1 deep
DIN508-M8	7.0	17.0	7.0	15.0	10.0	6 x \varnothing 16H7-3.1 deep

Linear modules MKK

MKK-040/-065/-080/-110/-140/-NN-3 Motor attachment dimension drawings

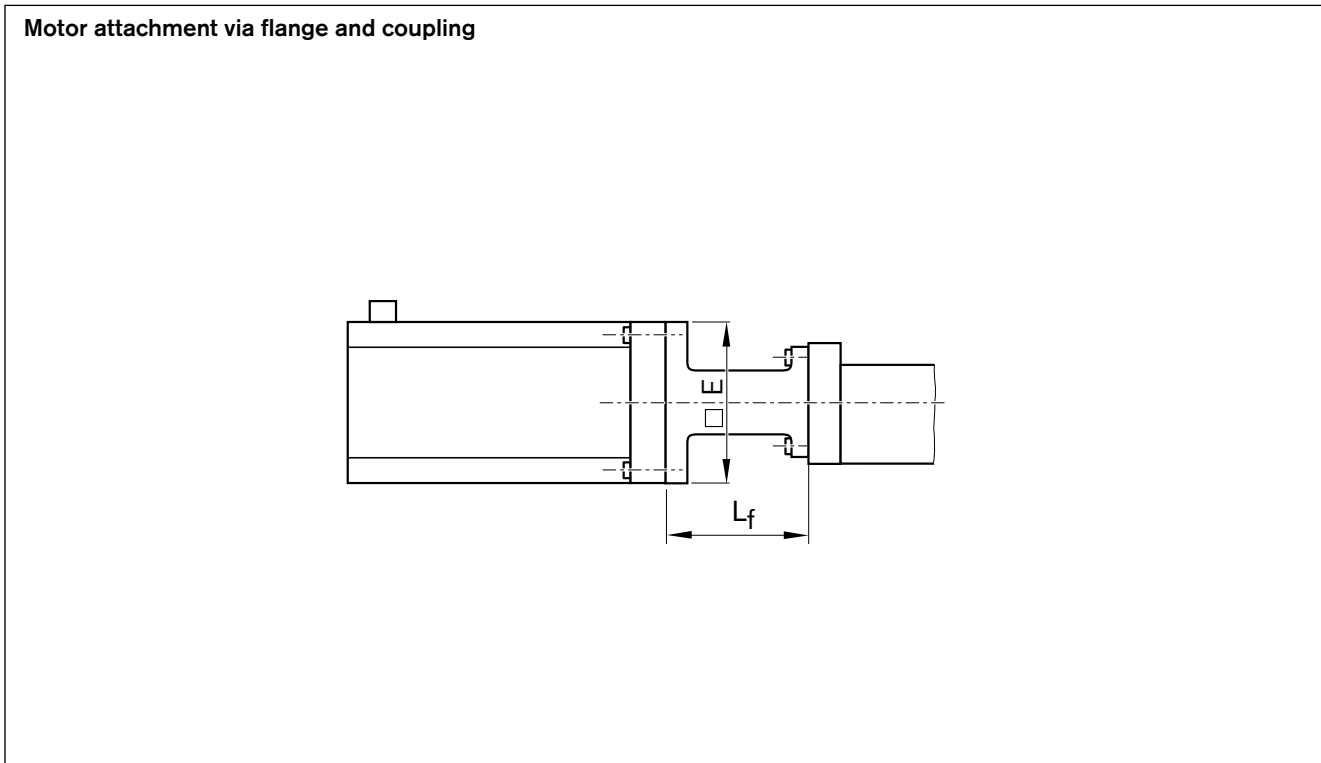

MKK	Motor code	Dimensions (mm)	
		□ E	L _f
-040-NN-3	MS2N03-BOBYN	see dimension □ A ➡ "Motors" chapter	50.0
	MSM019B-0300		45.0
	MSM031B-0300		50.0
-065-NN-3	MSM041B-0300		83.0
	MS2N04-C0BTN		77.5
-080-NN-3	MSM041B-0300		90.0
	MS2N04-B0BTN		95.0
	MS2N04-C0BTN		
	MS2N04-D0BQN		
-110-NN-3	MS2N05-B0BTN		115.0
	MS2N06-B1BNN		125.0
	MS2N06-C0BTN		
	MS2N06-D0BRN		
MS2N06-D1BNN			
-140-NN-3	MS2N07-B1BNN	140.0	
	MS2N07-C1BRN		
	MS2N07-D1BNN		

Further information about motors ➡ "Motors" chapter

Motor attachment via timing belt side drive

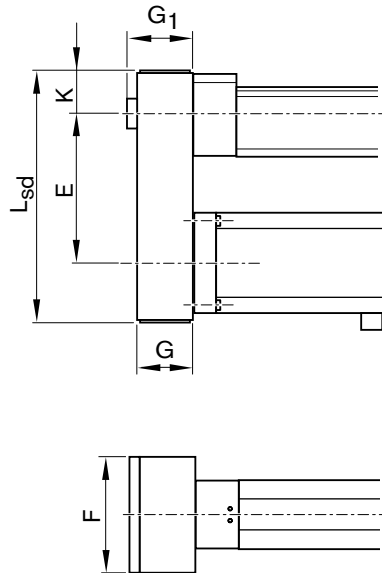

MKK	Motor code	Dimensions (mm)							
		E			F	G	G ₁	K	L _{sd}
		i = 1	i = 1.5	i = 2					
-040-NN-3	MS2N03-B0BYN	78	75	-	64.5	37.0	43.5	33.5	154
	MSM019B-0300	76.5		-	48.0	27.5	29.0	27.5	140
	MSM031B-0300	78	75	-	64.5	37.0	43.5	33.5	157
-065-NN-3	MSM041B-0300	122		-	88.0	51.0	57.0	45.5	231
	MS2N04-B0BTN	122		-	88.0	51.0	-	47.5	231
-080-NN-3	MSM041B-0300	122		-	88.0	51.0	-	47.5	231
	MS2N04-C0BTN	122		-	88.0	51.0	-	47.5	231
	MS2N04-D0BQN	122	-	-	88.0	51.0	-	47.5	231
	MS2N04-B0BTN	-	122	-	88.0	51.0	-	47.5	231
	MS2N05-C0BTN	155	-	-	116.0	66.0	-	56.0	287
	MS2N05-D0BRN	-	-	155	116.0	66.0	-	56.0	287
-110-NN-3	MS2N06-B1BNN	165	-	-	116.0	66.0	-	58.5	300
	MS2N06-D1BNN	165	-	-	116.0	66.0	-	58.5	300
	MS2N06-C0BTN	-	-	162	116.0	66.0	-	58.5	300
-140-NN-3	MS2N07-B1BNN	240	-	238	160.0	90.0	-	77.0	409
	MS2N07-C1BRN	240	-	238	160.0	90.0	-	77.0	409
	MS2N07-D1BNN	240	-	238	160.0	90.0	-	77.0	409

Further information about motors ➔ "Motors" chapter

MKK-165-NN-2

Dimensional drawings

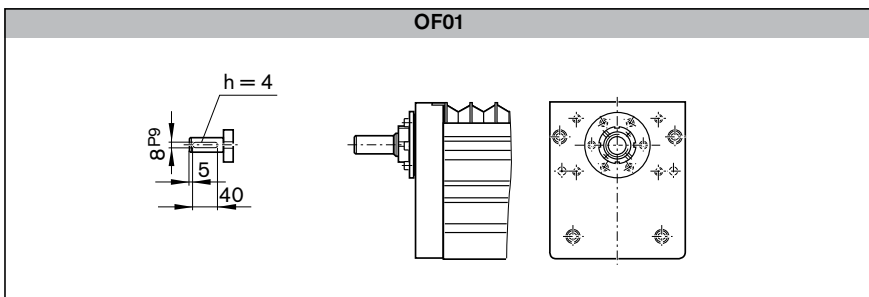
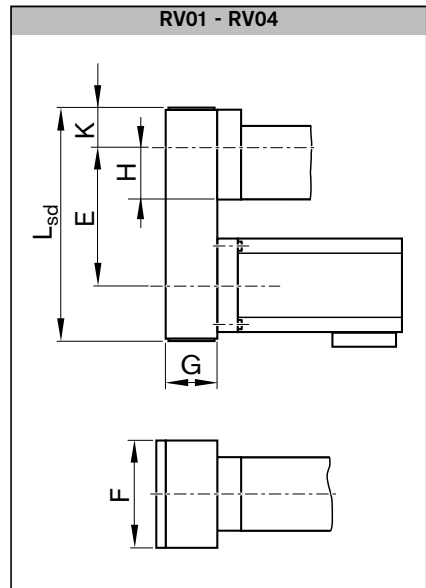
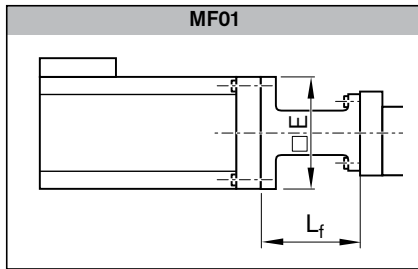
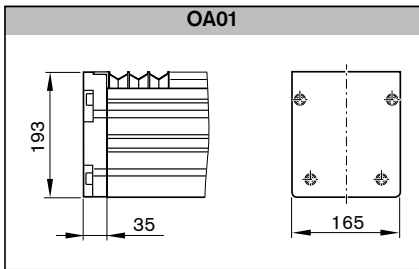
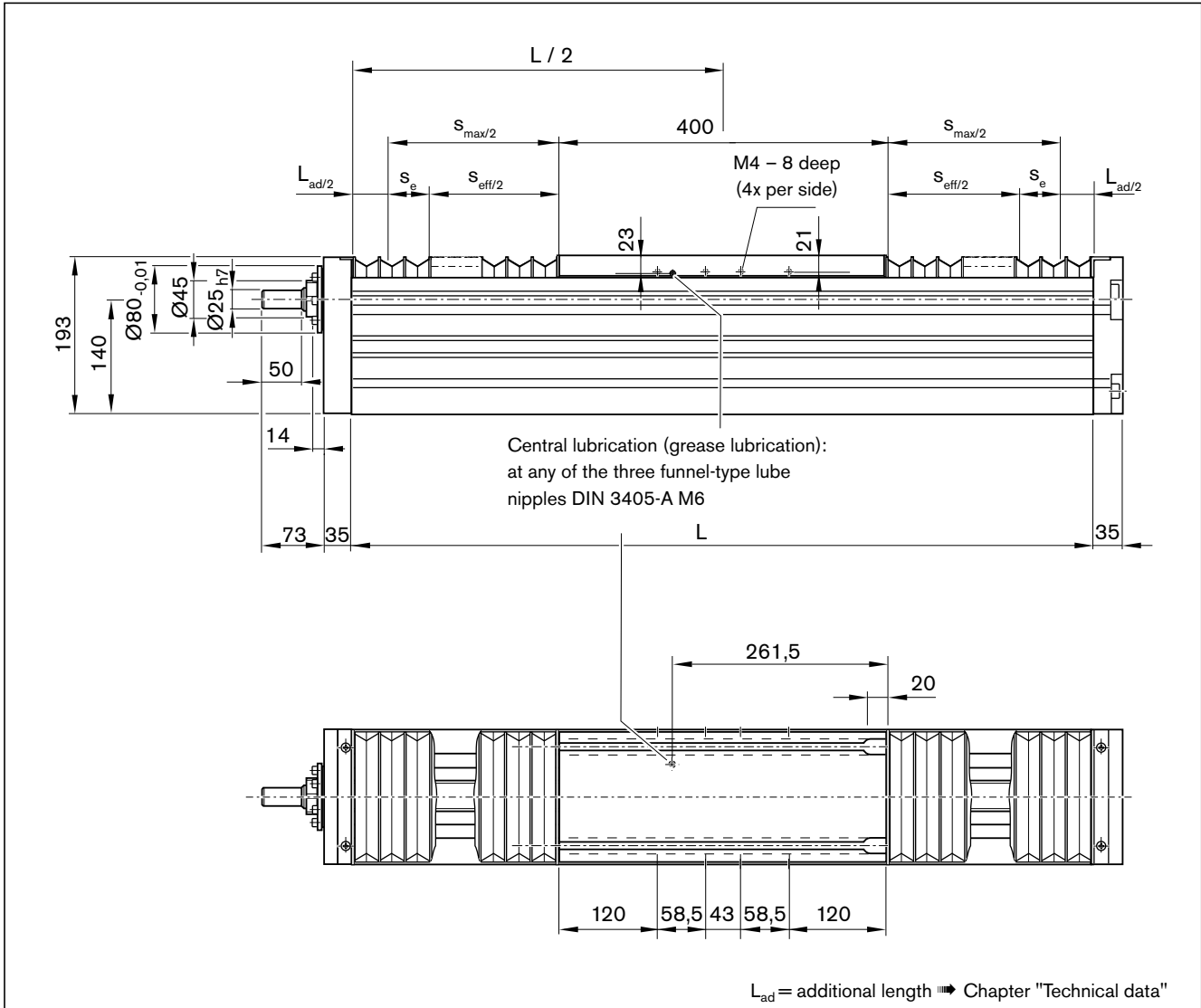

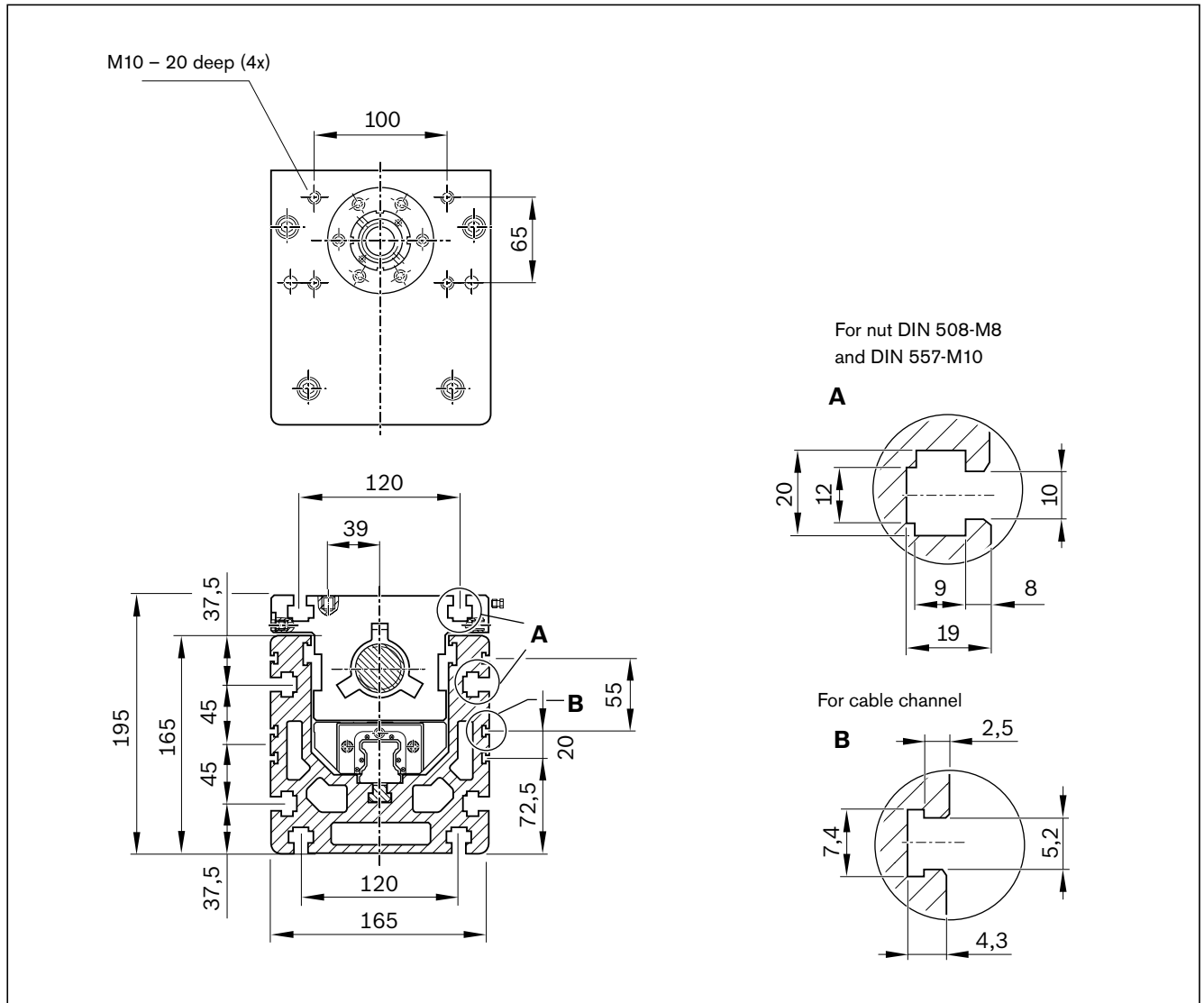

Version	Motor code	Dimensions (mm)									
		i = 1	i = 1.5	i = 2	E	□ E	L _f	F	G	H	K
RV01 - RV04	MS2N07-C0BQN	240	-	238	-	-	160	90	140	77	409
	MS2N07-C1BRN			238							
	MS2N07-D0BRN			238							
	MS2N07-E0BQN			-							
MF01	MS2N07-C0BQN	-	-	-	1) ¹⁾	148	-	-	-	-	-
	MS2N07-C1BRN										
	MS2N07-D0BRN										
	MS2N07-E0BQN										

¹⁾ see dimension □ A ➔ "Motors" chapter

Further information about motors ➔ "Motors" chapter

Linear modules MKR

Product description MKR-xxx-NN-3

Features

- Ready-to-install linear modules in any length up to L_{max}
- Realization of greater lengths of up to 9,800 mm
- Extremely compact aluminum profile with integrated Rexroth ball rail system with moderate preload (preload class C1)
- High travel speed combined with the wear-resistance typical of rolling-element high precision over long lengths
- High-performance toothed belt in the largest possible overall width for high drive torques with simultaneously high rigidity
- Carriages made of aluminum, in two design versions, with T-slots or threaded holes and with centering holes in each case
- Protection of the guide and drive components by sealing strip (plastic strip on MKR-040/-065, corrosion resistant steel strip on MKR-080/-110/-140)
- Economical maintenance thanks to the one-point lubrication feature (grease lubrication or oil lubrication) from both sides via the carriage
- Repeatability of up to ± 0.05 mm

Further highlights

- Available in two material versions, ALST (aluminum/steel version) and ALCR (aluminum/steel hard chrome plated version)
- Center holes also in frame profile for simple combination with other linear motion systems and connection elements
- Absolute length measuring system IMS-A directly integrated into the guide system (MKR-080/-110/-140)
- Standard with integrated solenoid switch for magnetic field sensors
- Extensive accessories for connection and clamping elements and connecting shafts
- Nameplate with parameters for easy start-up
- Special version: Profile frame also interconnectable as multiple parts for lengths $> L_{max}$ (on request)

Attachments

- Planetary gearbox with various gear ratios
- Attachment kits for motor according to customer specification
- Servo motor
- Magnetic field sensors for easy assembly directly on the profile frame
- Switch (proximity or mechanical) cable channel, socket-plug and extension cables in the accessories program

Example variants



One drive journal,
Long carriage with thread

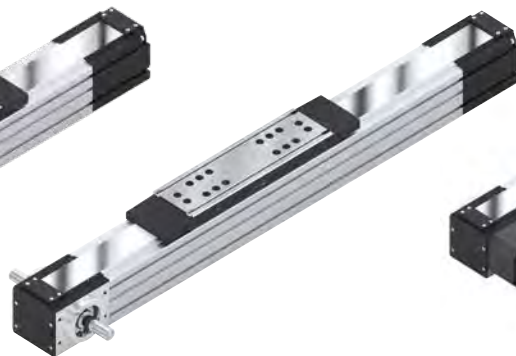

Two drive journals,
Long carriage with T-slots



Planetary gear with motor,
Long carriage with T-slots

Material pairing

ALST:

- Frame, carriage and end enclosures made of anodized aluminum (AL)
- MKR-065/-080/-110/-140/-145: ball guide rail and ball runner block made of rolling bearing steel (ST)
- MKR-040: Ball guide rail and ball runner block of rust and acid resistant material
- Deep-groove ball bearing of the drive mechanism (belt pulleys) made of rolling bearing steel

ALCR:

- Frame, carriage and end enclosures made of anodized aluminum (AL)
- MKR-065/-080/-110/-140/-145: Ball guide rail made of rolling bearing steel with corrosion resistant coating, matte-silver finish, hard chrome plated (Resist CR). ball runner block made of corrosion-resistant steel (Resist NR)
- MKR-040: Ball guide rail and ball runner block of rust and acid resistant material
- Deep-groove ball bearing of the drive mechanism (belt pulleys) made of rolling bearing steel

Lubrication versions

LSS: (Initial lubrication done at the factory)

- Initial standard greasing done at the factory, suitable for normal environmental conditions.
- Simple relubrication via manual grease gun.

MKR-065/-080/-110/-140/-145:

- Grease lubricant Dynalub 510, lithium-based high-performance grease of the NLGI grade 2 according to DIN 51818 (KP2K-20 according to DIN 51825)

MKR-040:

- Grease lubricant Dynalub 520, lithium-based high-performance grease of the NLGI grade 00 according to DIN 51818 (GP00K-20 according to DIN 51826)

LPG: (Corrosion prevention, no initial lubrication)

- Linear module without initial greasing done at the factory.
- Ball rail System, only with corrosion prevention.
- Basic lubrication required

LCF: (prepared for connection to central lubrication systems with liquid grease)

- For liquid grease, NLGI grade 00 lithium-based high-performance grease according to DIN 51818 (GP00K-20 according to DIN 51826)
- Only use liquid grease lubrication with single-line total-loss lubrication systems via piston distributors.
- Basic lubrication required

LCO: (prepared for connection to central lubrication systems with oil)

- Ball runner block with integrated non-return valves
- Only use oil lubrication with single-line total-loss lubrication systems via piston distributors.
- Basic lubrication required

Product description for Integrated Measuring System

The IMS-A measuring system offers the following advantages:

- No additional space required.
- No additional mounting surfaces required for the measuring system.
- No measurement inaccuracies due to parallelism offset between the measuring system and the guide system.
- Full integration of the measuring system components into the guide means no complex mounting or tuning work is needed.
- The runner block, scanner and guide rail with scale can be replaced individually during servicing.
- Interfaces: HIPERFACE (HF) or DRIVE-CLiQ (DQ).
- Connecting cable directly on the side of the carriage.
- For further information, see the "Integrated Measuring System" chapter

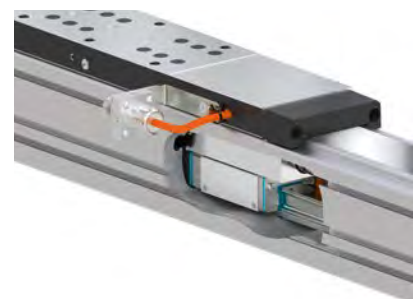

Linear modules MKR

Product description MKR-165-NN-2

Features

Linear modules with ball rail system and belt drive for high speeds and high demands on the guideway. The integrated, backlash-free Rexroth ball rail system makes it possible for large masses to be moved at high speed thanks to high load ratings and optimal travel.

The Linear modules comprise:

- A compact anodized aluminum frame
- The integrated Rexroth ball rail system
- A carriage with T-slots for fixtures, with central lubrication point
- High-performance toothed belt (AT profile)
- A cover provided by the toothed belt
- Mountable switches
- Servo motor
- Gear reducer for motor attachment

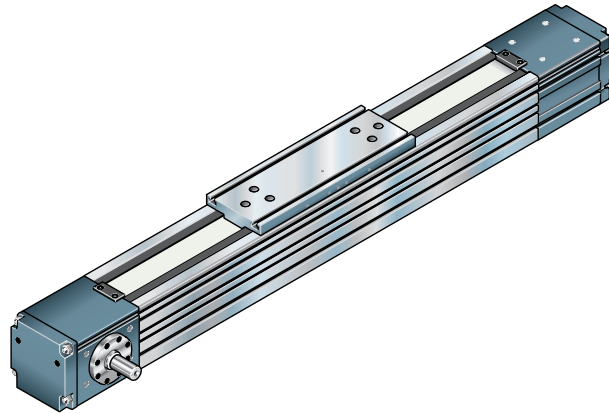

Structural design

Structural design

- 1 Drive end enclosure
- 2 Toothed belt (covered)
- 3 Carriage with runner block
- 4 Sealing strip for MKR-040/-065/-080/-110/-140
- 5 Strip fixing for MKR-040/-065/-080/-110/-140
- 6 Idler end enclosure
- 7 Frame

Attachments:

- 8 Cable channel
- 9 Switching angle
- 10 Proximity switch
- 11 Mechanical switch
- 12 Socket/plug
- 13 Magnetic field sensor

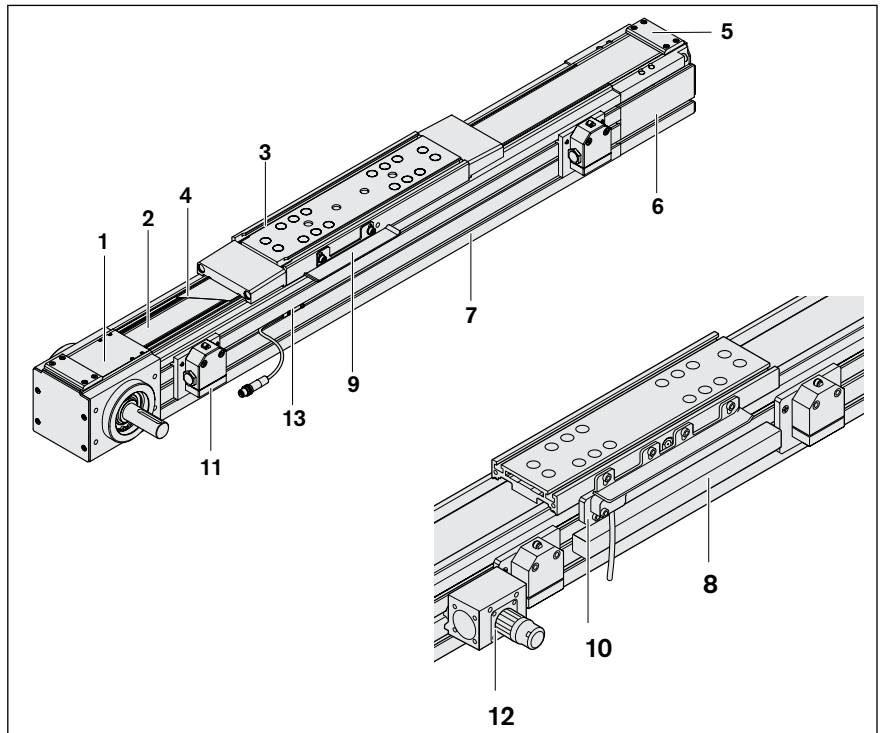

Types

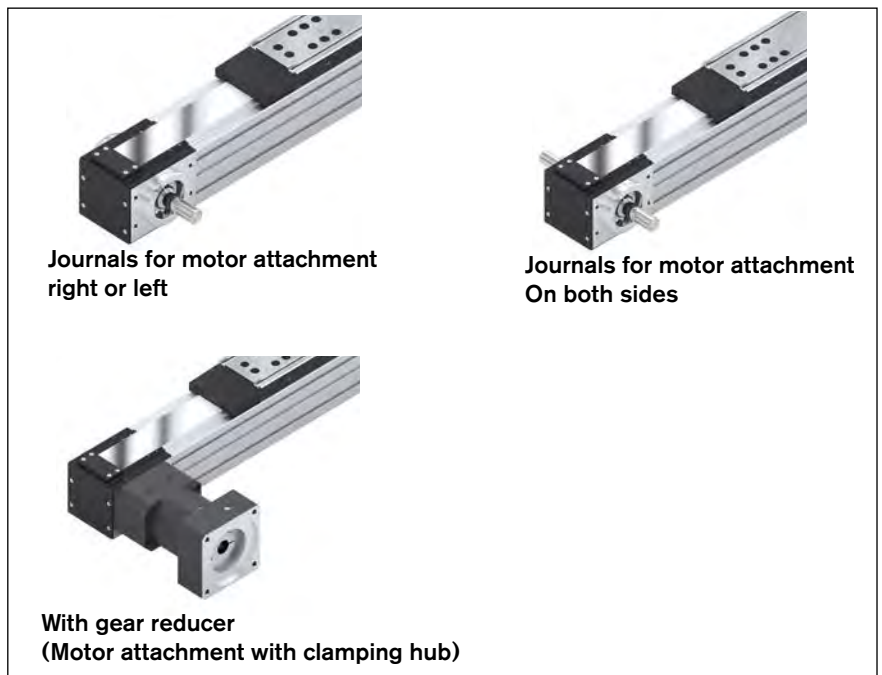

Carriage variants MKR-xxx-NN-3

For further information, see the chapter on "Carriage dimension drawings"

Carriage with T-slots short (S)	long (L)	with threads short (S)	long (L)

Linear modules MKR

Technical data

General technical data

Observe the "Project planning/calculation" chapter!

MKR	Carriage length		Dyn. characteristics			Maximum permissible loads				Moved mass of system m_{ca} (kg)
	L_{ca} (mm)	$L_w^{1)}$ (mm)	Dynamic load capacities C_{gw} (N)	Dynamic load moments M_t (Nm)	$M_L^{2)}$ (Nm)	Max. permissible moments $M_{x\ max}$ (Nm) $M_{y\ max}^{3)}$ (Nm) $M_{z\ max}^{3)}$ (Nm)			Max. permissible forces $F_{y\ max} / F_{z1\ max} / F_{z2\ max}$ (N)	
-040-NN-3	135	–	3 750	22.3	129.5	12	65	65	1 875	0.29
-065-NN-3	190	–	16 000	154	569	62	227	227	6 400	1.1
	2 x 190 (2 TT)	variable min = 234 max = 804	32 000	308	8.0 x L_w	123	3.2 x L_w	3.2 x L_w	12 800	2.2
-080-NN-3	190	–	23 400	300	200	120	80	80	9 360	1.4
	260	–	38 000	487	2 470	192	990	990	15 200	2.6
	2 x 260 (2 TT)	variable min = 404 max = 1004	76 000	974	19 x L_w	384	7.5 x L_w	7.5 x L_w	30 400	5.2
	360 (with IMS)		38 000	487	2 470	192	990	990	15 200	3.5
-110-NN-3	210	–	28 600	410	290	164	116	116	11 440	2.6
	305	–	46 500	666	2 790	264	1 120	1 120	18 600	4.1
	2 x 305 (2 TT)	variable min = 441 max = 1201	93 000	1332	23.2 x L_w	528	9.2 x L_w	9.2 x L_w	37 200	8.2
	410 (with IMS)	–	46 500	666	2 790	264	1 120	1 120	18 600	4.9
-140-NN-3	370	–	59 300	1 023	4 151	409	1 660	1 660	23 700	8.0
	2 x 370 (2 TT)	variable min = 652 max = 2032	118 600	2 046	29.6 x L_w	818	11.8 x L_w	11.8 x L_w	47 400	16.0
	500 (with IMS)		59 300	1 023	4 151	409	1 660	1 660	23 700	9.8
-165-NN-2	400	–	84 100	1 800	5 130	720	2 130	2 130	34 100	11.5

¹⁾ Variable centerline-to-centerline distance defined by customer-built mounting base.

Centerline-to-centerline distance between minimum and maximum distance in 5 mm steps, in 10 mm steps on MKR-110, in 15 mm steps on MKR-140 available.

²⁾ Determine dynamic longitudinal load moment M_t with variable carriage centerline-to-centerline distance according to the selected centerline-to-centerline distance.

³⁾ Determine maximum permissible longitudinal moments $M_{y\ max}$ and $M_{z\ max}$ at variable carriage centerline-to-centerline distance according to the selected centerline-to-centerline distance.

⁴⁾ Minimum required travel distance to ensure a reliable lubrication distribution.

For operating conditions, see the section titled "Additional information". If values are not met, please contact Bosch Rexroth.

⁵⁾ Maximum permissible length L_{max} with measuring system (IMS)

	Version/ gear unit	Constants mass calculation		Additional length L_{ad} (mm)	Min. travel range $s_{min}^{(4)}$ (mm)	Max. length L_{max} (mm)	Application point of the effective force z_1 (mm)	Planar moments of inertia						
		$k_g \text{ fix}$ (kg)	$k_g \text{ var}$ (kg/mm)					I_y (cm ⁴)	I_z (cm ⁴)					
	0000	0.25	0.0025	10	50	2 500	34.5	10.53	14.61					
	F010, F011	0.52	0.0027											
	G010, G011	0.60												
	0000	0.20	0.0066	94	60	5 900	49.0	78.4	92.5					
	F010, F011, F020	2.40	0.0068	32										
	G010, G011	2.70												
	F010, F011, F020	2.40												
	G010, G011	2.70												
	F010, F011, F020	2.40												
	G010, G011	2.70												
	0000	0.25	0.0099	162	60	6 000 4 500 ⁵⁾	59.5	150	212					
	F010, F011, F020	3.40	0.0102	17										
	G010, G011	4.10												
	0000	0.40	0.0102	17										
	F010, F011, F020	3.40												
	G010, G011	4.10												
	F010, F011, F020	3.40												
	G010, G011	4.10												
	F010, F011, F020	3.40												
	G010, G011	4.10												
	G010, G011	4.10												
	0000	0.30	0.0156	160						60	9 400 4 500 ⁵⁾	74.5	495	641
	F010, F011, F020	6.80	0.0162	11										
	G010, G011 (i = 3, i = 5)	7.40												
	G010, G011 (i = 10)	7.60												
	0000	0.40	0.0162	11										
	F010, F011, F020	6.80												
	G010, G011 (i = 3, i = 5)	7.40												
	G010, G011 (i = 10)	7.60												
	F010, F011, F020	6.80												
	G010, G011 (i = 3, i = 5)	7.40												
	G010, G011 (i = 10)	7.60												
	F010, F011, F020	6.80												
	G010, G011 (i = 3, i = 5)	7.40												
	G010, G011 (i = 10)	7.60												
	G010, G011 (i = 10)	7.60												
	0000	0.55			0.0264	220	80	9 800 4 500 ⁵⁾	123.0	1 485	1 904			
	F010, F011, F020	16.65	0.0269	27										
	G010, G011	18.10												
	F010, F011, F020	16.65												
	G010, G011	18.10												
	F010, F011, F020	16.65												
	G010, G011	18.10												
	OA01	29.50	0.0384	40	80	12 000	123.0	2 574	3 527					
	MA01 – MA03	29.50												
	MG01, MG02 (i = 8)	36.00												
	MG01, MG02 (i = 12, i = 16)	36.00												

Length calculation ➡ "Project planning/calculation" chapter
 Short product names ➡ "Abbreviations" chapter

Linear modules MKR

Technical data

Drive data/gear unit data

Observe the "Project planning/calculation" chapter!

MKR	Gear type ¹⁾	Gear ratio i (-)	Max. acceleration torque (at the gear output)	Base frictional torque	Max. drive speed
			$M_{Rs}^{2)}$ (Nm)	M_{Rge} (Nm)	$n_{ge}^{2)}$ (min ⁻¹)
-040-NN-3	PG040	5	14	0.10	18 000
		10	5	0.10	18 000
-065-NN-3	PG060	3	45	0.15	13 000
		5	64	0.10	13 000
		10	24	0.10	13 000
-080-NN-3	PG080	3	136	0.60	7 000
		5	176	0.50	7 000
		10	61	0.45	7 000
-110-NN-3	PG080	3	136	0.60	7 000
		5	176	0.40	
	PG120	3	184	1.20	6 500
		5	312	0.90	
		10	152	0.65	
-140-NN-3	PG120	5	312	0.90	6 500
		12 ³⁾	416	0.80	6 500
				0.95	
		16 ³⁾	416	0.80	6 500
0.95					
-165-NN-2	PG160	8	720	1.20	6 500
		12 ³⁾	1 280	2.10	
		16 ³⁾	1 280	2.20	

¹⁾ Planetary gearbox

²⁾ The limits of the linear motion system must not be exceeded. Further information about the calculation  "Project planning/calculation" chapter

³⁾ Two-stage gear

	Motor	Mass moment of inertia	Weight	
			J_{ge} (kgm ²)	m_{ge} (kg)
	MS2N03-D		0.0000065	0.60
	MSM031B		0.0000065	0.60
	MS2N03-D		0.0000062	0.60
	MSM031B		0.0000062	0.60
	MS2N03-D		0.0000128	0.90
	MS2N04		0.0000135	0.90
	MSM041B		0.0000369	1.20
	MS2N03-D		0.0000080	0.90
	MS2N04		0.0000100	0.90
	MSM031C		0.0000100	0.90
	MSM041B		0.0000347	1.20
	MS2N03-D		0.0000065	0.90
	MS2N04		0.0000085	0.90
	MSM031C		0.0000085	0.90
	MSM041B		0.0000345	1.20
	MS2N06		0.0001521	3.00
	MS2N05		0.0001521	2.80
	MSM041B		0.0001521	2.00
	MS2N06		0.0001290	3.00
	MS2N05		0.0001290	2.80
	MSM041B		0.0001290	2.00
	MS2N06		0.0001246	3.00
	MS2N05		0.0001246	2.80
	MSM041B		0.0001246	2.00
	MS2N06		0.0001520	3.00
	MS2N06		0.0001290	3.00
	MS2N07		0.0004723	7.40
	MS2N07		0.0003995	7.40
	MS2N06		0.0001378	6.20
	MS2N07		0.0003744	7.40
	MS2N07		0.0003995	7.40
	MS2N06		0.0002220	8.20
	MS2N07		0.0004586	9.40
	MS2N06		0.0001740	8.20
	MS2N07		0.0004108	9.40
	MS2N07		0.0004630	18.00
	MS2N07		0.0012400	22.00
	MS2N07		0.0007500	22.00

Linear modules MKR

Technical data

Drive data/gear unit data

Observe the "Project planning/calculation" chapter!

MKR	Gear ratio	Max. drive torque	Feed constant	Max. speed	Carriage
	i (-)	M _p (Nm)	u (mm/rev)	v _{max} (m/s)	L _{ca} (mm)
-040-NN-3	1 ¹⁾	4.50	90.0	3.0	135
	5 ²⁾	0.90	18.0	3.0	135
	10 ²⁾	0.45	9.0	2.7	
-065-NN-3	1 ¹⁾	12.00	125.0	5.0	190
	1 (with keyway) ³⁾			5.0	2 x 190
	3 ²⁾	4.00	41.7	5.0	190
	5 ²⁾	2.40	25.0	5.0	2 x 190
	10 ²⁾	1.20	12.5	2.7	
-080-NN-3	1 ¹⁾	36.00	205.0	5.0	190
	1 (with keyway) ³⁾				5.0
	3 ²⁾	12.00	68.33	5.0	190
	5 ²⁾	7.20	41.0	4.7	260
	10 ²⁾	3.60	20.5	2.4	360 (with IMS)
					2 x 260
-110-NN-3	1 ¹⁾	100.00	290.0	5.0	210
	1 (with keyway) ³⁾				5.0
	3 ²⁾	33.30	96.67	5.0	210
	5 ²⁾	20.00	58.0	5.0	305
	10 ²⁾	10.00	29.0	3.1	410 (with IMS)
					2 x 305
-140-NN-3	1 ¹⁾	300.00	360.0	5.0	370
	1 (with keyway) ³⁾				5.0
	5 ²⁾	60.00	72.0	5.0	370
	12 ²⁾	25.00	30.0	3.2	500 (with IMS)
	16 ²⁾	18.75	22.5	2.4	2 x 370
-165-NN-2	1 ¹⁾	367.00	440.0	5.0	400
	1 (with keyway) ³⁾	200.00			
	8 ²⁾	45.00	55.0	4.0	400
	12 ²⁾	30.00	36.7	3.0	
	16 ²⁾	23.00	27.5	2.0	

¹⁾ Valid for versions: 1 or 2 drive journals

²⁾ Valid for versions: clamping hub or clamping hub with 2nd journal

³⁾ Version with keyway

⁴⁾ Maximum force that can be transmitted via the teeth meshing with the belt pulley.

⁵⁾ The maximum permissible tensile load on the belt cross section (belt elasticity limit) is given here for easier comparability. This value represents the load limit in terms of plastic deformation and may not be used to calculate the maximum permissible drive torque.

	Constants mass moment of inertia			Frictional torque M_{RS} (Nm)	Belt pulley diameter d_3 (mm)	Belt type B_t	Max. belt drive transmission force $F_{bp}^{4)}$ (N)	Belt elasticity limit $F_{tperm}^{5)}$ (N)	Specific spring rate C_{spe} (N)	Max. acceleration a_{max} (m/s ²)																																																																																																														
	k_{Jfix} (kgmm ²)	k_{Jvar} (kgmm)	k_{Jm} (mm ²)																																																																																																																					
	81.8	0.0151	172	0.49	28.65	20AT3	314	760	0.2 x 10 ⁵	50																																																																																																														
	79.0											538.00	0.0832	396	1.20	39.79	32AT5	600	2 240	0.56 x 10 ⁶		973.00	1.80		544.00	1.20		979.00	1.80		2157.00	0.3188	1 065	1.70	65.25	46AT5	1 100	3 200	0.81 x 10 ⁶		3114.00	2.00		4070.00	2.00		5660.00	2.90		2240.00	1.70		3197.00	2.00		4153.00	2.00		5750.00	2.90		7252.00	1.2326	2 125	3.10	92.31	50AT10	2 160	8 500	2.12 x 10 ⁶		10 441.00	3.90		12 140.00	3.90		19 154.00	5.70		7482.00	3.10		10 671.00	3.90		12 370.00	3.90		19 385.00	5.70		32 215.00	3.8113	3 286	9.60	114.59	60AT15	5 233	14 770	3.80 x 10 ⁶		37 886.00	9.60		58 467.00	12.10		32 630.00	9.60		38 301.00	9.60		58 882.00	12.10		70 428.00	7.0600	4 904
	538.00	0.0832	396	1.20	39.79	32AT5	600	2 240	0.56 x 10 ⁶																																																																																																															
	973.00			1.80																																																																																																																				
	544.00			1.20																																																																																																																				
	979.00			1.80																																																																																																																				
	2157.00	0.3188	1 065	1.70	65.25	46AT5	1 100	3 200	0.81 x 10 ⁶																																																																																																															
	3114.00			2.00																																																																																																																				
	4070.00			2.00																																																																																																																				
	5660.00			2.90																																																																																																																				
	2240.00			1.70																																																																																																																				
	3197.00			2.00																																																																																																																				
	4153.00			2.00																																																																																																																				
	5750.00			2.90																																																																																																																				
	7252.00	1.2326	2 125	3.10	92.31	50AT10	2 160	8 500	2.12 x 10 ⁶																																																																																																															
	10 441.00			3.90																																																																																																																				
	12 140.00			3.90																																																																																																																				
	19 154.00			5.70																																																																																																																				
	7482.00			3.10																																																																																																																				
	10 671.00			3.90																																																																																																																				
	12 370.00			3.90																																																																																																																				
	19 385.00	5.70																																																																																																																						
	32 215.00	3.8113	3 286	9.60	114.59	60AT15	5 233	14 770	3.80 x 10 ⁶																																																																																																															
	37 886.00			9.60																																																																																																																				
	58 467.00			12.10																																																																																																																				
	32 630.00			9.60																																																																																																																				
	38 301.00			9.60																																																																																																																				
	58 882.00	12.10																																																																																																																						
	70 428.00	7.0600	4 904	14.50	140.05	75AT20	5 250	18 000	4.2 x 10 ⁶																																																																																																															
	72 485.00																																																																																																																							

Linear modules MKR

Technical data

Deflection

Observe the "Project planning/calculation" chapter!

Example

Linear module MKR-080:
 L = 3000 mm F = 1000 N
 From chart -080:
 f = 1.55 mm $f_{max} = 3.75$ mm

The deflection f lies well below the maximum permissible deflection f_{max} , so no additional supports are required.

The graphs apply under the following conditions:

- both ends firmly fixed (200 to 250 mm per side)
- 6 to 8 screws per side
- solid mounting base
- observe L_{max} ; see general technical data

MKR-040-NN-2

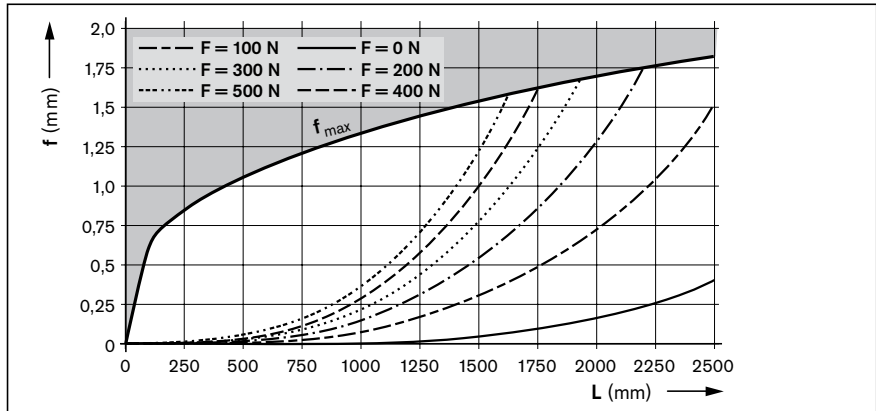

MKR-065-NN-3

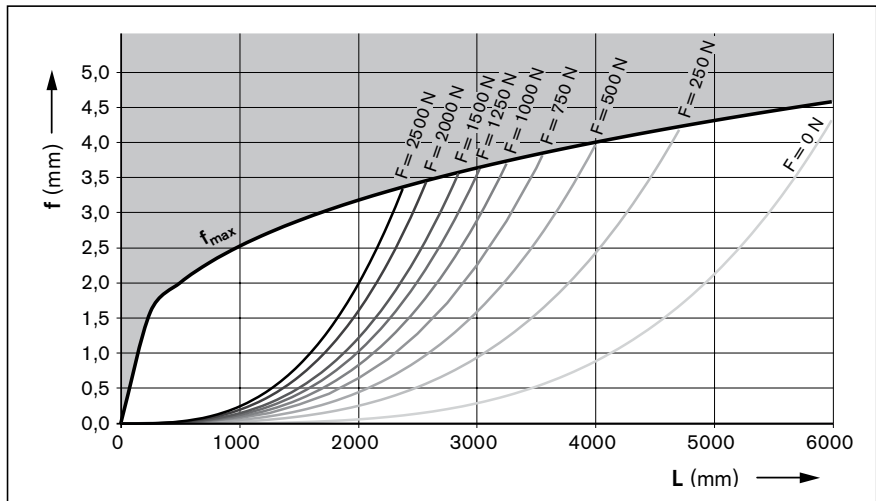

MKR-080-NN-3

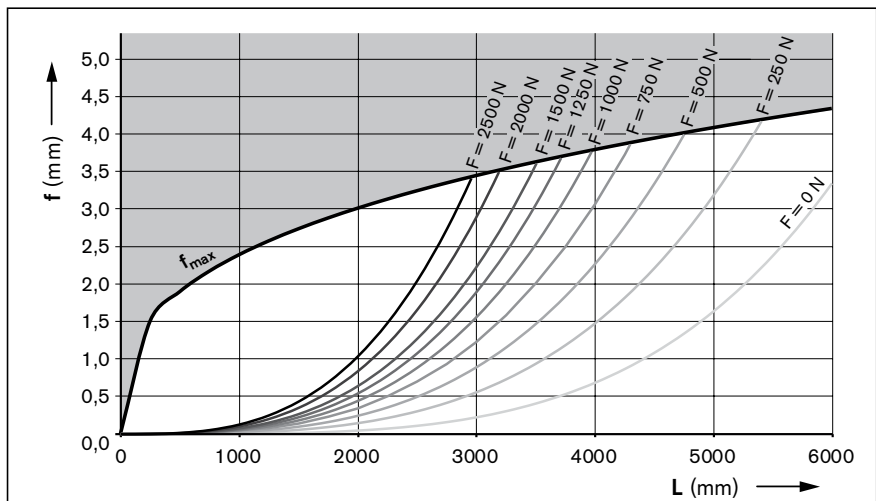

MKR-110-NN-3

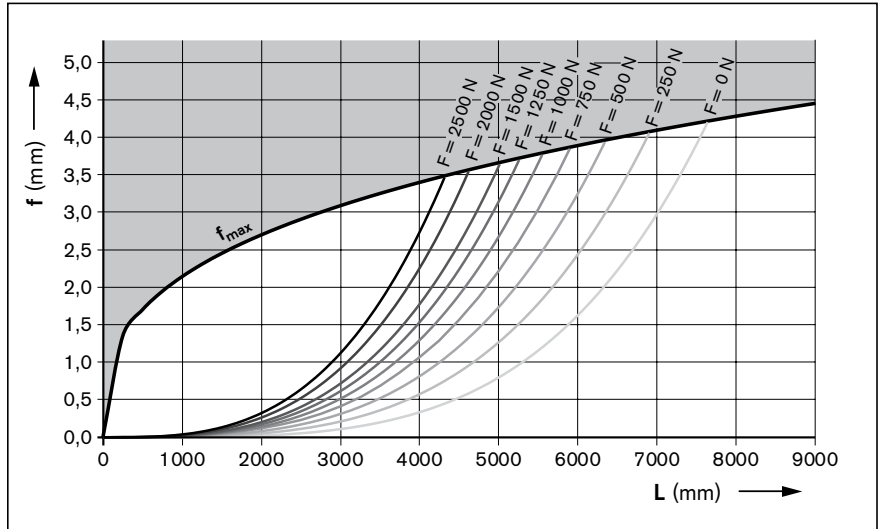

MKR-140-NN-3

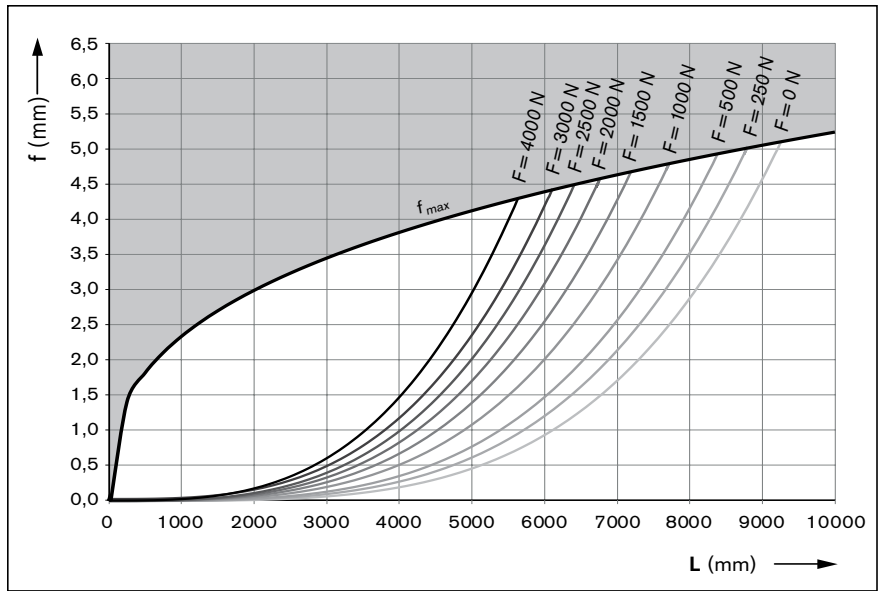

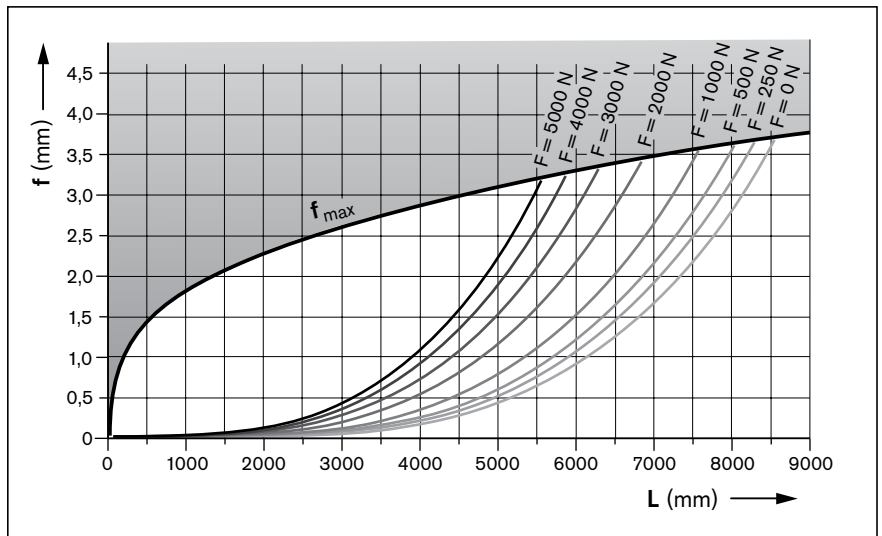

MKR-165-NN-2



Linear modules MKR

MKR-040-NN-3

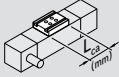
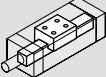
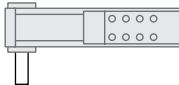
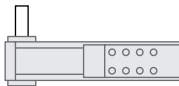
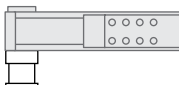
Configuration and ordering





s _{max} ¹⁾ (mm)	Material pairing ²⁾	Lubrication ³⁾ 	Carriage 			Guideway ⁴⁾ 	Version
			Thread (T)	L (L _{ca} = 135 mm)	Number TT	Frame with or without center holes	
s _{max} =	ALST	LSS	T	L	1	001 without	F010 
		LCF					F011 
		LCO				G010 	
		LPG				G011 	

1) Travel distance s_{max} depends on length L and option selection Length calculation ➡ "Project planning/calculation" chapter
 2) Material pairing ➡ Chapter "Product description MKR-xxx-NN-3".
 3) Lubrication ➡ see chapter "Additional Information".
 4) Center holes for simple combination with other linear motion systems and connection elements (see dimensional drawings).
 Option 004: with center holes and long hole in the ground area of the frame from travel distance S_{min} ≥ 155 mm
 5) Mounting kit with gear unit also available without motor.
 6) Further switch mounting options ➡ see chapter "Switching system".

Drive journal

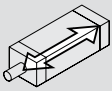
Versions G010 and G011 offer a drive journal, which can be accessed by removing the cover.



	Drive 		Mounting interface ⁵⁾	Gearing		Motor 					Cover 		Sensor system ⁶⁾ Quantity: 1 - 6	Documen- tation 
	Drive journal	Clamping hub		Gear ratio	Mechanical interface	Motor code	1 cable	2 cable	with	without	Motor connector position	Cover		
	001	-	-	-	-	-	-	-	-	-	0 without			
	002	-	-	-	-	-	-	-	-	-	0 without			
		005	000 011	i = 1	-	-	-	-	-	-		0 without		
						MSM031B	MSM031B-0300	-	2		000			
				i = 5				Y	N		090			
				i = 10		MS2N03-D	MS2N03-D0BYN				180			
		006				MS2N03-B	MS2N03-B0BYN	1	2		270			
											2 with			
												000 without sensor; 130 sensor (PNP NC); 131 sensor (NPN NC) 132 sensor (PNP NO); 133 sensor (NPN NO)		
													001 standard; 002 frictional torque; 005 positioning accuracy	

Version	Motor connector position			
	0°	90°	180°	270°
G010/G011	000	090 ★	180	270

★ Standard delivery (connector position)

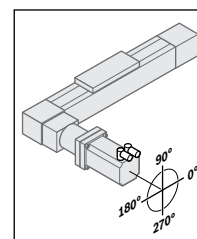

MKR-065-NN-3

Configuration and ordering

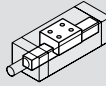
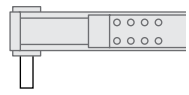
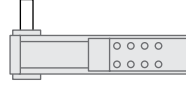
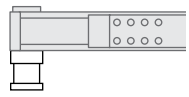
s _{max.} ¹⁾ (mm)	Material pairing ²⁾	Lubrication ³⁾ 	Carriage			L _w (mm) (2 TT only)	Guideway ⁴⁾  Frame with or without center holes	Version				
			T-slot (S) Thread (T)	L (L _{ca} = 190 mm)	Number TT							
s _{max} =	ALST	LSS	S	L	2	L _w =	001 without					
			T	L								
			LCF	S					1	-	004 with	
				LCO								
		LPG		T								
		ALCR	LSS	S	L		1	-	011 without			
											LCF	T
	LCO											
											LPG	

1) Travel distance s_{max} depends on length L and option selection Length calculation → "Project planning/calculation" chapter
 2) Material pairing → Chapter "Product description MKR-xxx-NN-3".
 3) Lubrication → see chapter "Additional Information".
 4) Frame with center holes only possible up to a length of L = 5 500 mm.
 5) Mounting kit with gear unit also available without motor.
 6) Further switch mounting options → see chapter "Switching system".

	Drive			Mounting interface ⁵⁾	Gearing		Motor					Cover		Sensor system ⁶⁾	Documentation
	Without slot	With keyway	Clamping hub		Gear ratio	Mechanical interface	Motor code	Con-connector		Holding brake		Motor connector position	Cover		
							1 cable	2 cable	with	without				Quantity: 1 - 6	
	001	003	-	-	-	-	-	-	-	-	-	0 without	0 without	000 without sensor; 120 sensor (PNP NC); 121 sensor (NPN NC) 122 sensor (PNP NO); 123 sensor (NPN NO)	001 standard; 002 frictional torque; 005 positioning accuracy
	002	004													
	-	-	006	000 011	i = 1	-	-	-	-	-	-	2 with	0 without	000 without sensor; 120 sensor (PNP NC); 121 sensor (NPN NC) 122 sensor (PNP NO); 123 sensor (NPN NO)	
			016 with second journal	011	i = 3 i = 5 i = 10	MS2N03-D	MS2N03-D0BYN	1	2	Y	N		000		
						MS2N04	MS2N04-B0BTN						090		
						MS2N04-D0BQN	180								
			MSM041	MSM041B-0300	-	2	270								
			MSM031C	MSM031C-0300											



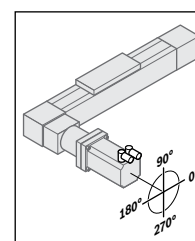

Version	Motor connector position			
	0°	90°	180°	270°
G010/G011	000	090 ★	180	270

★ Standard delivery (connector position)



MKR-080-NN-3

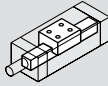
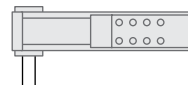

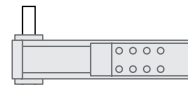
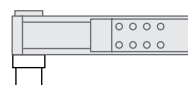
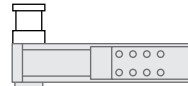





Configuration and ordering

s _{max.} ¹⁾ (mm)	Material pairing ²⁾	Lubrication ³⁾ 	Measuring system IMS- A ⁴⁾ 	Carriage			L _w (mm) (2 TT only)	Guideway ⁶⁾ 	Version	
				T-slot (S) Thread (T)	S (L _{ca} = 190 mm) L (L _{ca} = 260 mm) ⁵⁾	Number TT				
s _{max} ⁼	ALST	LSS	001 HF	S	L	1	-	104 with		
			002 DQ	T	L					
		000 without	S	L	2	L _w =	001 without			
		LCF	S	S						
	LCO	-	T	L	1	-	004 with			
	LPG									
	ALCR	LSS	-	-	S	S	1	-	011 without	
					LCF	S				
LCO		-	T	L	1	-	014 with			
LPG										

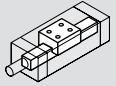
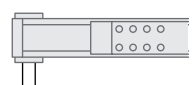
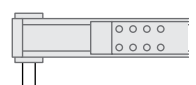
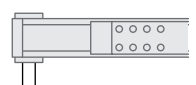
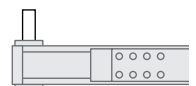
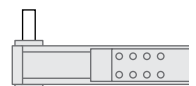
1) Travel distance s_{max} depends on length L and option selection Length calculation ➡ "Project planning/calculation" chapter
 2) Material pairing ➡ Chapter "Product description MKR-xxx-NN-3".
 3) Lubrication ➡ see chapter "Additional Information".
 4) Absolute measuring system, L_{max} = 4 500 mm (HF = HIPERFACE® interface, DQ = DRIVE-CLiQ interface).
 5) Carriage with measuring system, L_{ca} = 360 mm
 6) Frame with center holes only possible up to a length of L = 5 500 mm.
 7) Mounting kit with gear unit also available without motor.
 8) Further switch mounting options ➡ see chapter "Switching system".

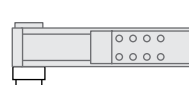
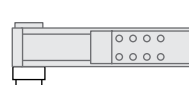
MKR-110-NN-3

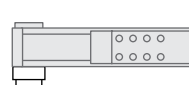
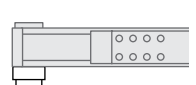
Configuration and ordering

s _{max} ¹⁾ (mm)	Material pairing ²⁾	Lubrication ³⁾ 	Measuring system IMS- A ⁴⁾ 	Carriage			L _w (mm) (2 TT only)	Guideway ⁶⁾  Frame with or without center holes	Version		
				T-slot (S) Thread (T)	S (L _{ca} = 210 mm) L (L _{ca} = 305 mm) ⁵⁾	Number TT					
s _{max} =	ALST	LSS	001 HF	S	L	1	-	104 with	F010 		
			002 DQ	T	L	1	-	104 with	F010 		
			000 without	S	L	2	L _w =	001 without	F010 		
		LCF	S	S	1	-	001 without	F011 			
			LCO	-	T	L	1	-	004 with	F011 	
			LPG	-	T	L	1	-	004 with	F020 	
	ALCR	LSS	-	S	S	1	-	011 without	G010 		
				LCO	-	T	L	1	-	014 with	G010 
				LPG	-	T	L	1	-	014 with	G011 
		LCF	S	S	1	-	011 without	G010 			
			LCO	-	T	L	1	-	014 with	G010 	
			LPG	-	T	L	1	-	014 with	G011 	

¹⁾ Travel distance s_{max} depends on length L and option selection Length calculation ➔ "Project planning/calculation" chapter

²⁾ Material pairing ➔ Chapter "Product description MKR-xxx-NN-3".

³⁾ Lubrication ➔ see chapter "Additional Information".

⁴⁾ Absolute measuring system, L_{max} = 4 500 mm (HF = HIPERFACE® interface, DQ = DRIVE-CLiQ interface).

⁵⁾ Carriage with measuring system, L_{ca} = 410 mm

⁶⁾ Frame with center holes only possible up to a length of L = 5 500 mm.

⁷⁾ Mounting kit with gear unit also available without motor.

⁸⁾ Further switch mounting options ➔ see chapter "Switching system".

	Drive		Mounting interface ⁷⁾	Gearing		Motor					Cover		Sensor system ⁸⁾	Documentation	
	Without slot	with keyway		Gear ratio	Mechanical Interface	Motor code	Con-connector		Holding brake		Motor connector position	Cover			Side sealing
							1 cable	2 cable	with	without			Quantity: 1 - 6		
	001	003	-	-	-	-	-	-	-	-	-	0 without	0 without	000 without sensor; 120 sensor (PNP NC); 121 sensor (NPN NC) 122 sensor (PNP NO); 123 sensor (NPN NO)	001 standard; 002 frictional torque; 005 positioning accuracy
	002	004										0 without			
	-	-	006	000 011	i = 1	-	-	-	-	-	-	2 with	1 with	000 without sensor; 120 sensor (PNP NC); 121 sensor (NPN NC) 122 sensor (PNP NO); 123 sensor (NPN NO)	001 standard; 002 frictional torque; 005 positioning accuracy
			016 With second journal	011	i = 3 i = 5	MS2N06	MS2N06-B1BNN	1	2	Y	N				
							MS2N06-D1BNN					090			
												180			
			008	000 012	i = 1	-	-	-	-	-	-				
							MS2N06-B1BNN	1	2	Y	N	000			
							MS2N06-D1BNN					090			
			018 with second journal	012	i = 3 i = 5 i = 10	MS2N07	MS2N07-B1BNN					180			
							MS2N07-C1BRN					270			
							MS2N07-D1BNN								

Version	Motor connector position			
	0°	90°	180°	270°
G010/G011	000	090 ★	180	270



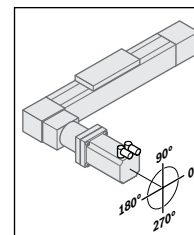

★ Standard delivery (connector position)



Linear modules MKR

MKR-140-NN-3

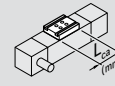
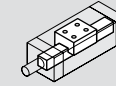
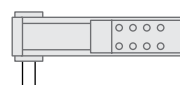
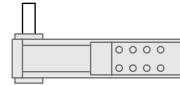
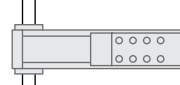
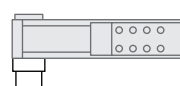
Configuration and ordering

s _{max} ¹⁾ (mm)	Material pairing ²⁾	Lubrication ³⁾ 	Measuring system IMS- A ⁴⁾ 	Carriage 			L _w (mm) (2 TT only)	Guideway ⁶⁾  Frame with or without center holes	Version
				T-slot (S) Thread (T)	L (L _{ca} = 370 mm) ⁵⁾	Number TT			
s _{max} =	ALST	LSS	001 HF	S	L	1	-	104 with	F010 
			002 DQ	T	L	1	-	104 with	F011 
			000 without	S	L	2	L _w =	001 without	F020 
		LCF	S	L	1	-	004 with	G010 	
			LCO	T	L	1	-	014 with	G011 
			LPG	-	-	-	-	-	-
	ALCR	LSS	S	L	1	-	011 without	-	
			LCO	T	L	1	-	014 with	-
			LPG	-	-	-	-	-	-
		LCF	S	L	1	-	011 without	-	
			LCO	T	L	1	-	014 with	-
			LPG	-	-	-	-	-	-

1) Travel distance s_{max} depends on length L and option selection Length calculation ➡ "Project planning/calculation" chapter
 2) Material pairing ➡ Chapter "Product description MKR-xxx-NN-3".
 3) Lubrication ➡ see chapter "Additional Information".
 4) Absolute measuring system, L_{max} = 4 500 mm (HF = HIPERFACE® interface, DQ = DRIVE-CLiQ interface).
 5) Carriage with measuring system, L_{ca} = 500 mm
 6) Frame with center holes only possible up to a length of L = 5 500 mm.
 7) Mounting kit with gear unit also available without motor.
 8) Further switch mounting options ➡ see chapter "Switching system".

Drive			Mounting interface ⁷⁾	Gearing		Motor					Cover		Sensor system ⁸⁾	Documentation
Without slot	with keyway	Clamping hub		Gear ratio	Mechanical interface	Motor code	Con- nector		Holding brake		Motor connector position	Cover		
						1 cable	2 cable	with	without				Quantity: 1 - 6	
001	003	-	-	-	-	-	-	-	-	-	0 without	0 without	000 without sensor; 120 sensor (PNP NC); 121 sensor (NPN NC) 122 sensor (PNP NO); 123 sensor (NPN NO)	001 standard; 002 frictional torque; 005 positioning accuracy
002	004	-	-	-	-	-	-	-	-	-	2 with	0 without		
-	-	008	000 012	i = 1	-	-	-	-	-	-	2 with	0 without		
-	-	018 With second journal	012	i = 12 i = 16	MS2N06	MS2N06-B1BNN	1	2	Y	N	000	1 with		
				i = 5 i = 12 i = 16	MS2N07	MS2N06-D0BRN					090			
						MS2N07-B1BNN					180			
						MS2N07-C1BRN					270			
						MS2N07-D1BNN								

Version	Motor connector position			
	0°	90°	180°	270°
G010/G011	000	090 ★	180	270

★ Standard delivery (connector position)

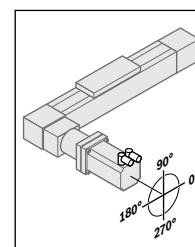

Linear modules MKR

MKR-165-NN-2

Configuration and ordering

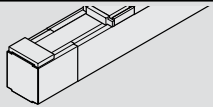
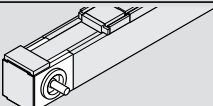
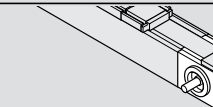
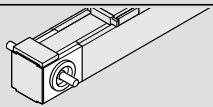
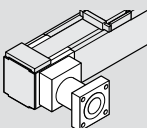
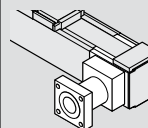



Short product name, length (L) Example: MKR-165-NN-2, (L) mm		Guideway	Drive				Carriage
Version			Drive journal	Gear ratio		with gear reducer	$L_{ca} = 400 \text{ mm}$
				$i = 1^{1)}$	$i = 1^{2)}$		
without drive	OA01 	01		50			05
with drive (MA), without gear unit $i = 1$	MA01 	01	right	01	03	-	
	MA02 	01	left	01	03	-	
	MA03 	01	on both sides	02	04	-	
with gear unit (MG), Gear reducer	MG01 	01	Gear reducer right/left	-	-	30	
	MG02 					31 with second journal	

1) Without keyway

2) With keyway

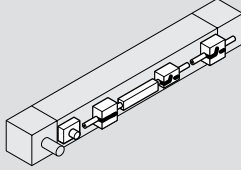
3) Attachment kit also available without motor (when ordering: enter "00" for motor).

Length calculation ➡ Section "General technical instructions"

Motor attachment		Motor						Motor connector position	Switches / Mounting channel / Socket-plug	Documentation
Gear ratio	Attachment kit ³⁾	Motor code	2 cable Brake		1 cable Brake		-			
			without	with	without	with				
-	-	-	-	-	-	-	-	Without switch and mounting channel 00 <hr/> Switches: - PNP NC 11 - PNP NO 13 - Mechanical 15 <hr/> Cable channel (loose) 20 <hr/> External socket-plug (loose) 17 <hr/> Switching cam at one end 16 <hr/> Switching cam at both ends 26		
-	-	-	-	-	-	-				
-	-	-	-	-	-	-				
-	-	-	-	-	-	-				
	i = 8	11	MS2N07-B1BNN	253	254	255	256	000	(Continuation of previous table content)	
			MS2N07-C1BRN	261	262	263	264			
			MS2N07-D1BNN	267	268	269	270			
	i = 12	21	MS2N07-B1BNN	253	254	255	256	090		
			MS2N07-C1BRN	261	262	263	264			
			MS2N07-D1BNN	267	268	269	270			
	i = 16	31	MS2N07-B1BNN	253	254	255	256	180		
			MS2N07-C1BRN	261	262	263	264			
			MS2N07-D1BNN	267	268	269	270			
			MS2N07-B1BNN	253	254	255	256	270		
			MS2N07-C1BRN	261	262	263	264			
			MS2N07-D1BNN	267	268	269	270			

Version	Motor connector position			
	0°	90°	180°	270°
MG01 / MG02	000	090 ★	180	270

★ Standard delivery (connector position)

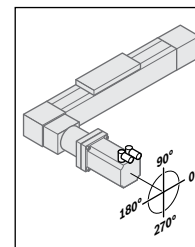

001 standard; 002 frictional torque; 005 positioning accuracy

Dimensional drawings MKR-040/-065/-080/-110/-140/-NN-3 Frame

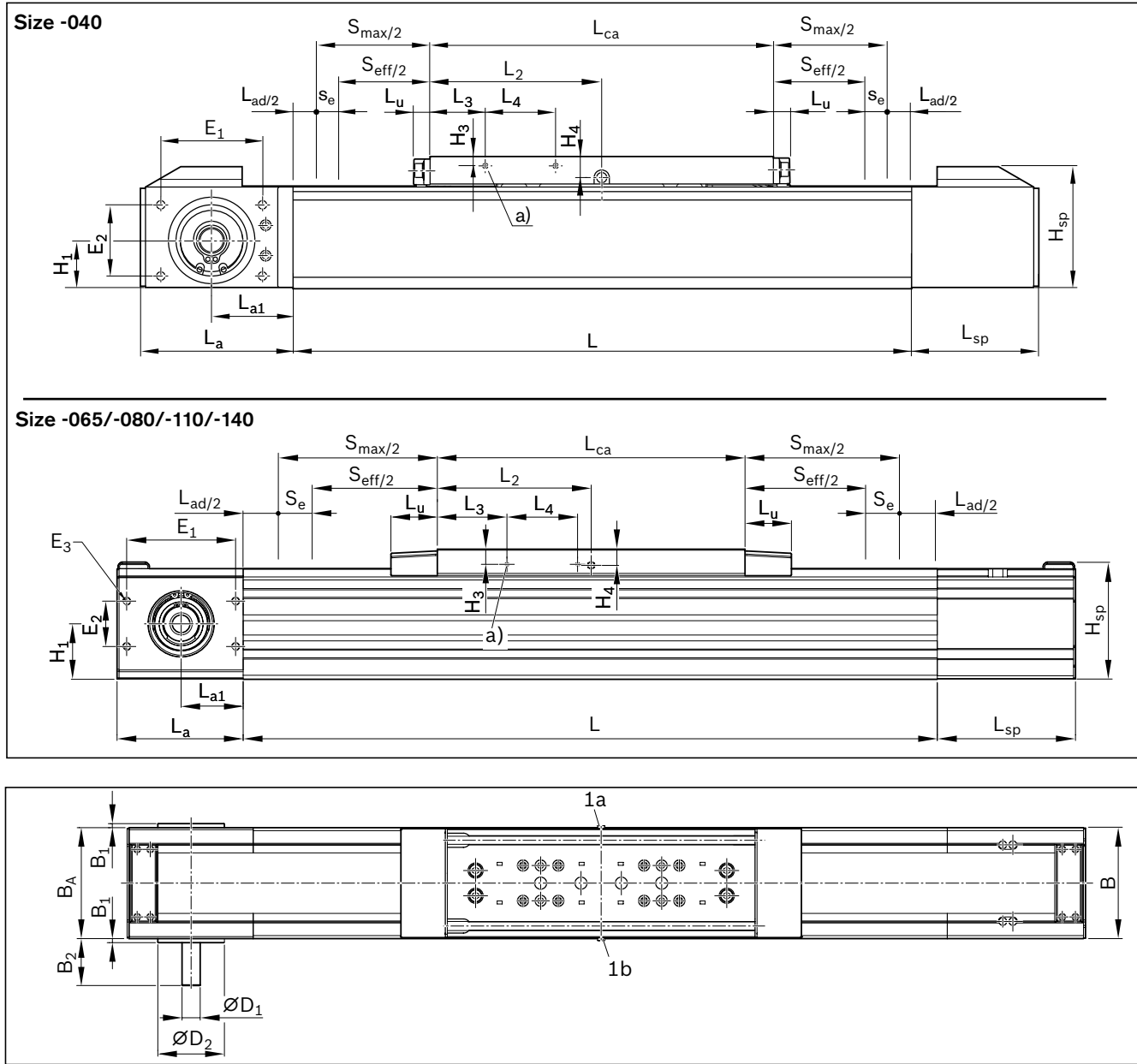

MKR	Dimensions (mm)														L _{ca}	L ₂	L ₃	L ₄		
	B	B _A	B ₁	B ₂	B ₃	B _S	Ø D ₁ h7	Ø D ₂ h7/H7	E ₁	E ₂	E ₃	H	H ₁	H ₃					H ₄	H _{sp}
-040-NN-3	40	52	1.6	20.0	12.5	-	10	34	40	28	M4-8 deep	52	19.0	3.7	8.3	48	135	67.5	20.0	27
-065-NN-3	65	80	5	30.0	30.0	-	16	47	60	49	M5-9 deep	85	30.2	13.5	13.5	75	190	95.0	60.0	70
-080-NN-3	80	80	10	53.0	53.0	-	18	66	84	39	M6-10 deep	100	41.0	11.5	12.5	90	190	140.5	47.5	
-080-NN-3																	260	130.0	47.5	
-110-NN-3	110	110	4	46.5	46.5	85	18	66	108	45	M8-18 deep	129	55.0	15.0	16.0	115	210	153.0	50.0	
-110-NN-3																	305	152.5	69.0	
-140-NN-3	140	140	14	72.0	72.0	105	35	112	120	62	M12-20 deep	170	71.5	19.0	19.0	147	370	185.0	70.0	

L_{ad} = additional length ➡ Chapter "Technical data"

See following pages for dimension drawings for carriages and motor attachment.

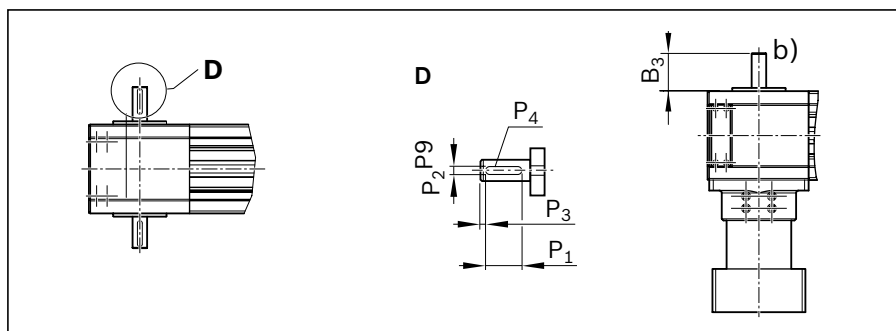
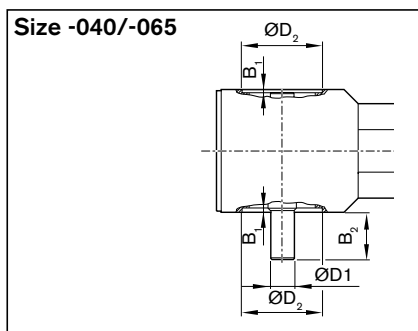
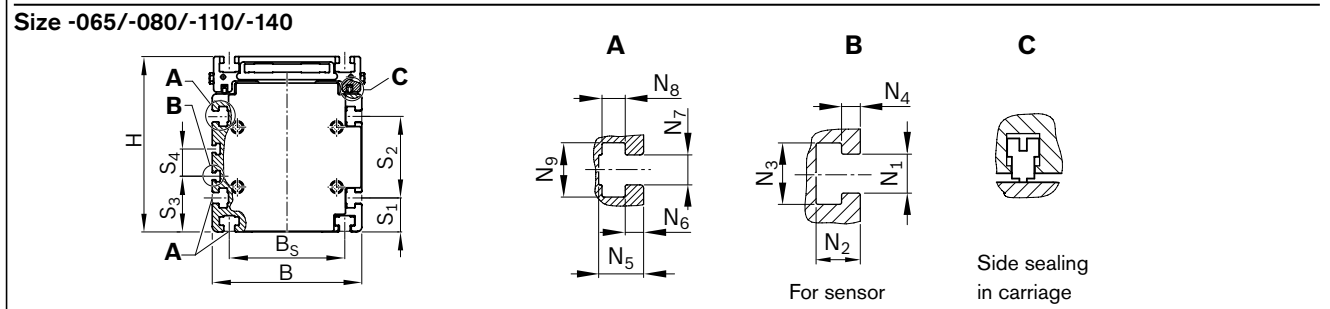
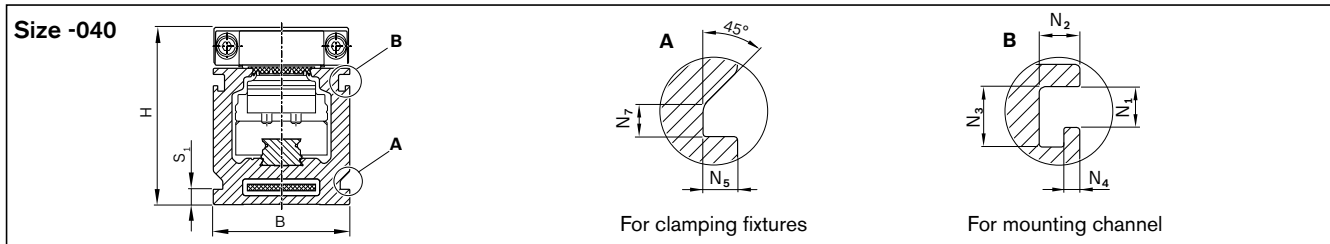
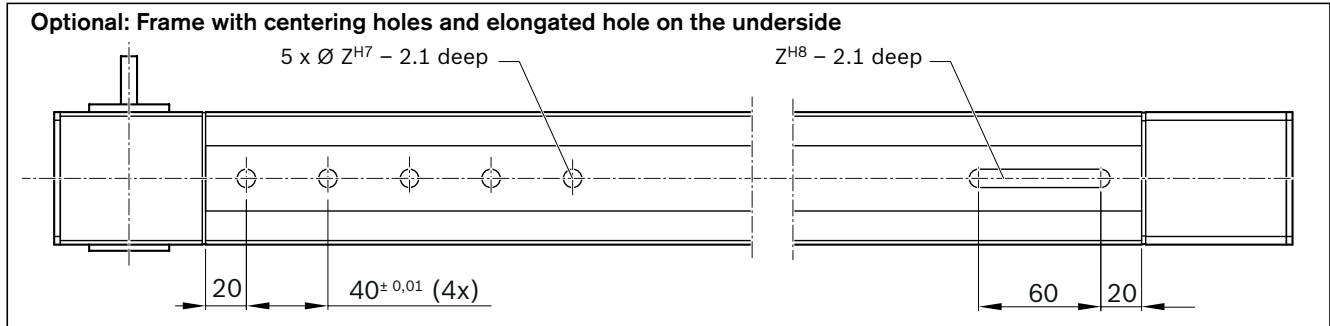

L _a	L _{a1}	L _u	L _{sp}	Sliding block	N ₁	N ₂	N ₃	N ₄	N ₅	N ₆	N ₇	N ₈	N ₉	P ₁	P ₂ P ₉	P ₃	P ₄ deep	S ₁	S ₂	S ₃	S ₄	Z
60	32.0	6.5	50	-	3.3	3.3	4.9	1.3	2.8	-	2.5	-	-	-	-	-	-	4.5	-	36.5	-	7
80	44.0	10	74	DIN557-M5	5.2	5.9	8.2	2.5	8.5	2.5	5.2	5.0	9.0	25	5	3	3.5	18.0	26	30.0	-	9
102	50.0	50	102	DIN557-M5	5.2	5.9	8.2	2.5	8.5	2.5	5.2	5.0	9.0	32	6	2	3.5	18.0	45	42.5	-	9
125	61.5	46	137	DIN508-M6	5.2	5.9	8.2	2.5	12.0	4.9	8.0	6.2	14.5	32	6	2	3.5	25.0	60	41.0	20	12
146	72.0	78	172	DIN508-M8	5.2	5.9	8.2	2.5	15.0	7.0	10.0	7.0	17.0	50	10	5	5.0	37.5	70	80.0	45	16

1a / 1b lube connection for guideway: lubrication on either of the two connections.
(Funnel-type lube nipple DIN 3405-A M6; Size -040: DIN 3405-A M3)

- a) Fastening thread M4-8 deep (4x) for switch bracket
- b) For drive option: Clamping hub with second journal (Ø D₁ x B₃)

MKR-040/-065/-080/-110/-140/-NN-3 Carriage dimension drawings

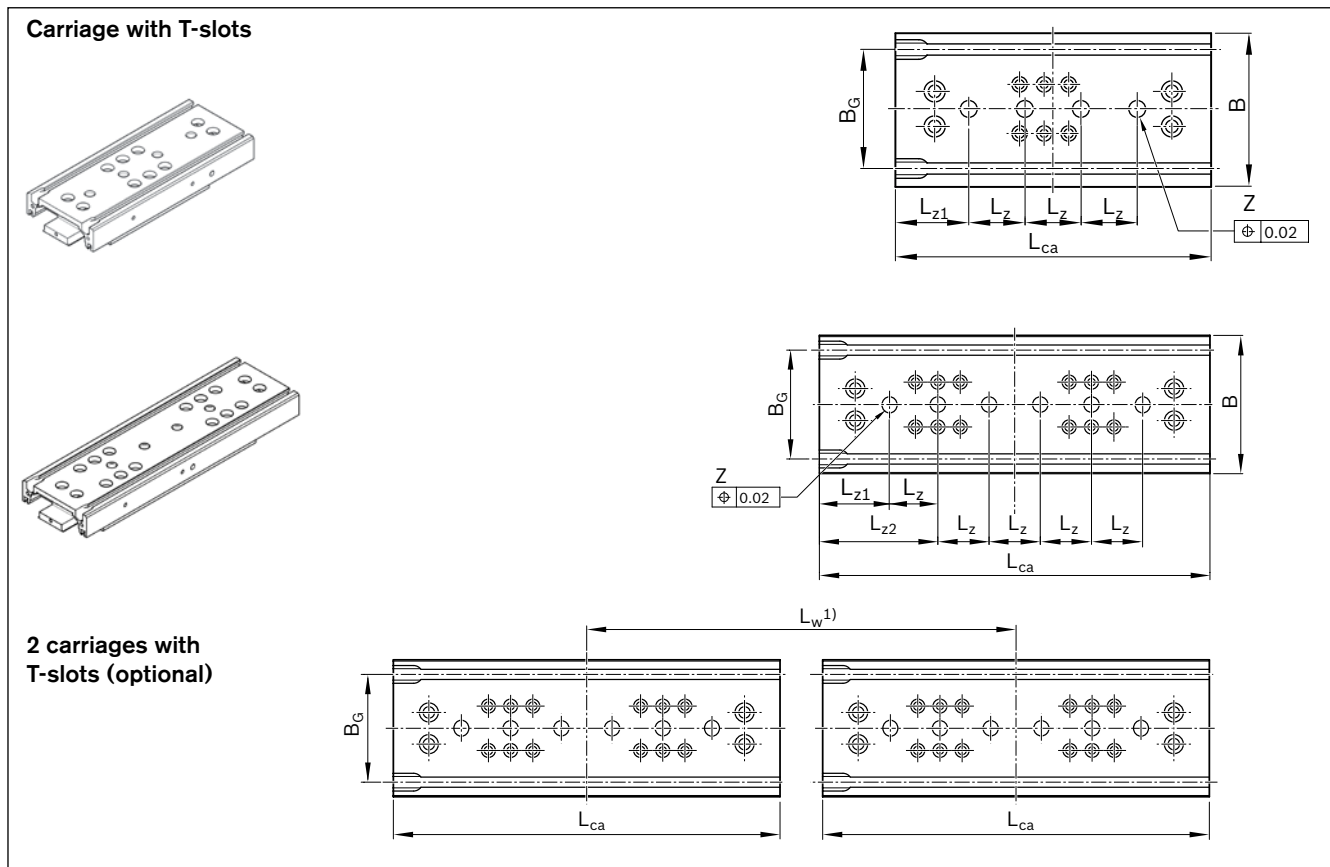
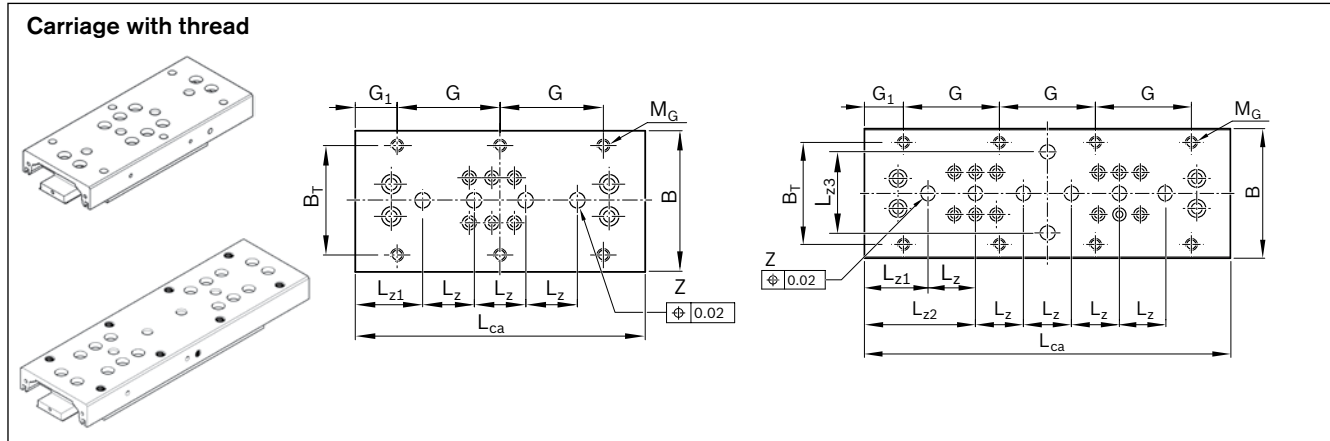

MKR	Dimensions (mm)														
	B	B _G	B _{IMS}	B _T	G	G ₁	H _{IMS}	L _{ca}	L _{ca IM S²⁾}	L _{w min}	L _{w max}	L _z	L _{z1}	L _{z2}	
-040-NN-3 (L _{ca} = 135)	39.5	-	-	30	30	25.0	-	135	-	-	-	20	37.5	-	
-065-NN-3 (L _{ca} = 190)	63.0	46	-	46	50	20.0	-	190	-	234	804	40	35.0	-	
-080-NN-3 (L _{ca} = 190)	78.0	60	-	60	70	25.0	-	190	-	-	-	40	35.0	-	
-080-NN-3 (L _{ca} = 260)	78.0	60	126	60	70	25.0	6.5	260	360	404	1004	40	70.0	-	
-110-NN-3 (L _{ca} = 210)	108.0	85	-	85	80	25.0	-	210	-	-	-	40	45.0	-	
-110-NN-3 (L _{ca} = 305)	108.0	85	156	85	80	32.5	8.0	305	410	441	1201	40	92.5	-	
-140-NN-3 (L _{ca} = 370)	138.0	105	186	105	105	27.5	12.0	370	500	652	2032	40	125.0	85	

¹⁾ Variable centerline-to-centerline distance defined by customer-built mounting base.
 Centerline-to-centerline distance between minimum and maximum distance in 5 mm steps, in 10 mm steps on MKR-110, in 15 mm steps on MKR-140 available.
²⁾ Clamping surface corresponds to L_{ca}
³⁾ Non-usable clamping surface

Carriage with threads and IMS

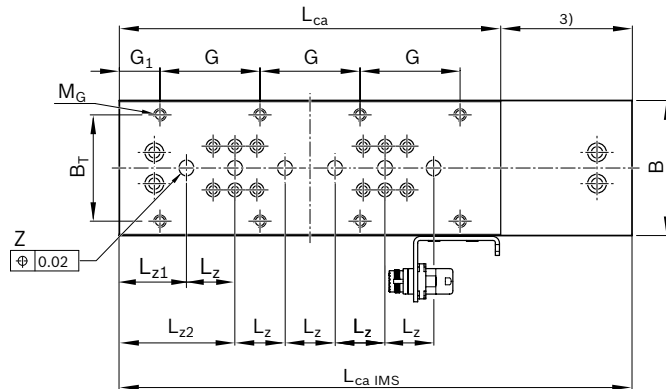
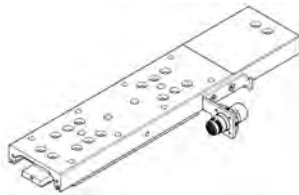

Carriage with T-slots and IMS

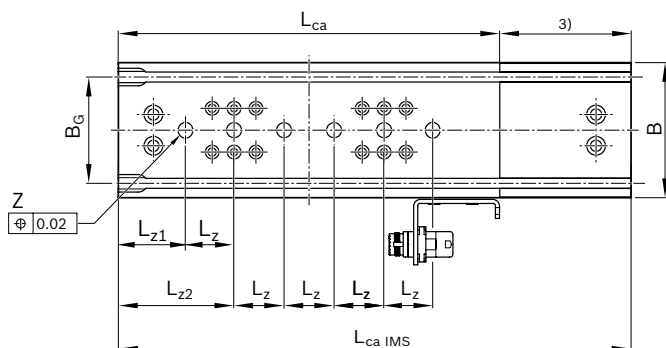
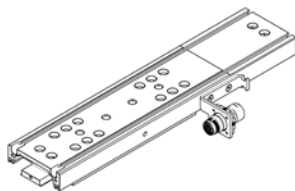

T-slots

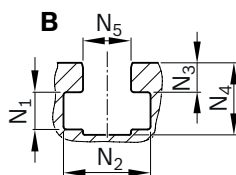
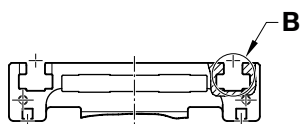

IMS connector

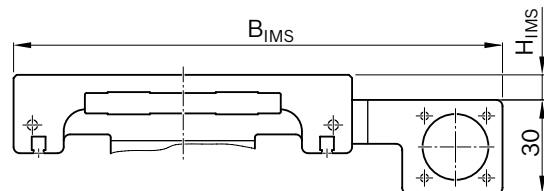

M _G	Sliding block	N ₁	N ₂	N ₃	N ₄	N ₅	ØZ
M4-9 deep (8x)	-	-	-	-	-	-	6 x Ø 7H7-1.6 deep
M6-9 deep (8x)	DIN557-M5	5.0	9.0	2.5	8.5	5.2	4 x Ø 9H7-2.1 deep
M8-10 deep (6x)	DIN557-M5	5.0	9.0	2.5	8.5	5.2	4 x Ø 9H7-2.1 deep
M8-10 deep (8x)	DIN557-M5	5.0	9.0	2.5	8.5	5.2	4 x Ø 9H7-2.1 deep
M10-12 deep (6x)	DIN508-M6	6.2	14.5	4.9	12.0	8.0	4 x Ø 12H7-2.1 deep
M10-12 deep (8x)	DIN508-M6	6.2	14.5	4.9	12.0	8.0	4 x Ø 12H7-2.1 deep
M10-18 deep (8x)	DIN508-M8	7.0	17.0	7.0	14.5	10.0	6 x Ø 16H7-3.1 deep

Linear modules MKR

MKR-040/-065/-080/-110/-140/-NN-3 Motor attachment dimension drawings

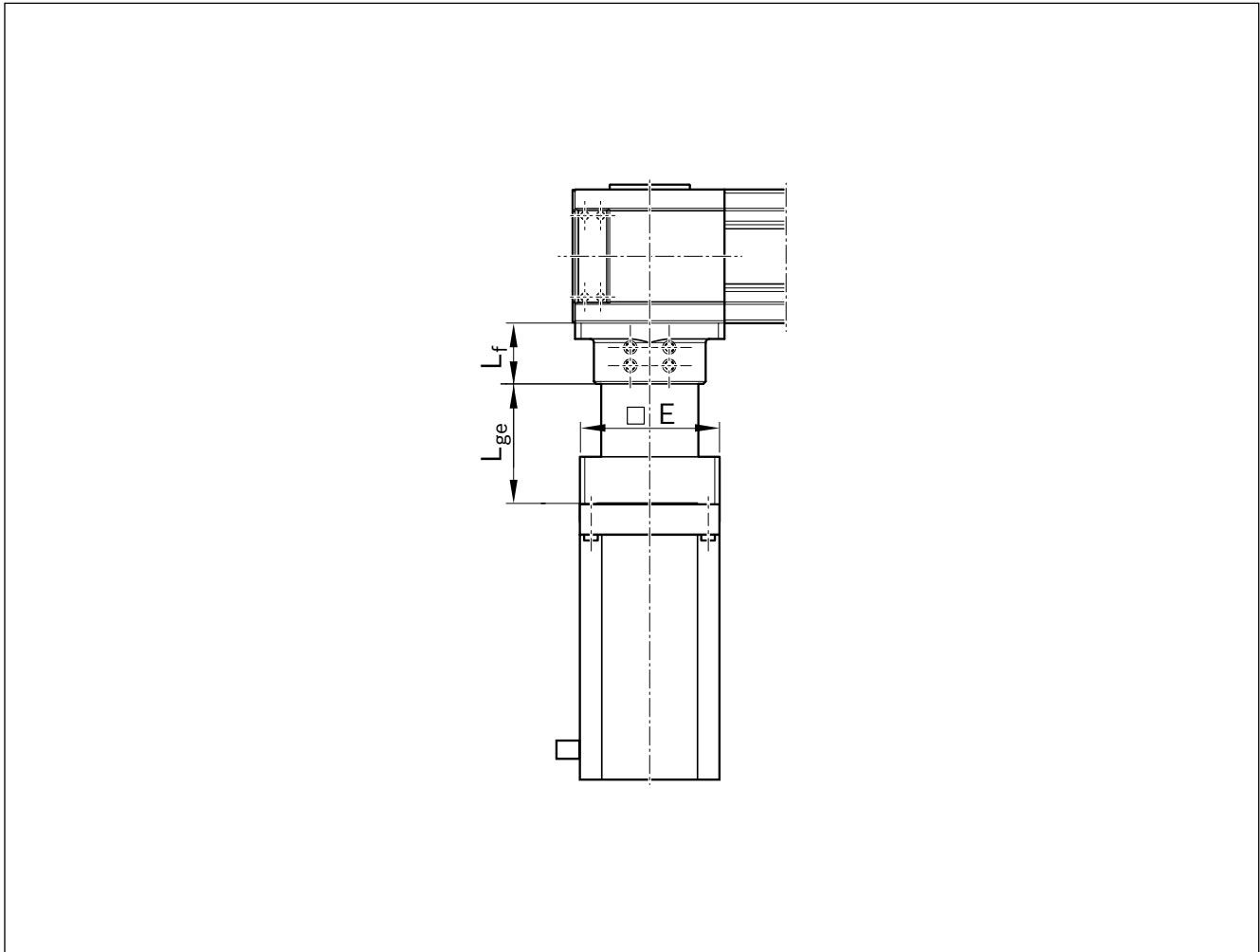

MKR	Gear ratio i	Motor code	Dimensions (mm)		
			E	L _f	L _{ge}
-040-NN-3	5 / 10	MS2N03-B0BYN	60	31.0	67.5
		MS2N03-D0BYN			
		MSM031B-0300			
-065-NN-3	3/5/10	MS2N03-D0BYN	60	36.5	71.0
		MS2N04-B0BTN	80		78.0
		MS2N04-C0BTN			
		MS2N04-D0BQN			
		MSM031C-0300	60		78.5
		MSM041B-0300	80		85.5
-080-NN-3	3/5/10	MSM041B-0300	80	54.0	98.5
		MS2N05-B0BTN	100		101.5
		MS2N05-C0BTN			
		MS2N05-D0BRN			
		MS2N06-B1BNN	115		113.5
		MS2N06-D1BNN			
-110-NN-3	3 / 5	MS2N06-B1BNN	115	50.0	113.5
		MS2N06-D1BNN			
	10	MS2N06-B1BNN	140	62.0	131.5
		MS2N06-D1BNN			
	3/5/10	MS2N07-B1BNN	140	62.0	147.0
		MS2N07-C1BRN			
MS2N07-D1BNN					
-140-NN-3	12 / 16	MS2N06-B1BNN	115	80.0	159.0
		MS2N06-C0BTN			
		MS2N06-D0BRN			
		MS2N06-D1BNN			
	5	MS2N07-B1BNN	140	80.0	147.0
		MS2N07-C1BRN			
		MS2N07-D1BNN			
	12 / 16	MS2N07-B1BNN	140	80.0	174.5
		MS2N07-C1BRN			
MS2N07-D1BNN					

Further information about motors → "Motors" chapter

MKR-165-NN-2

Dimensional drawings

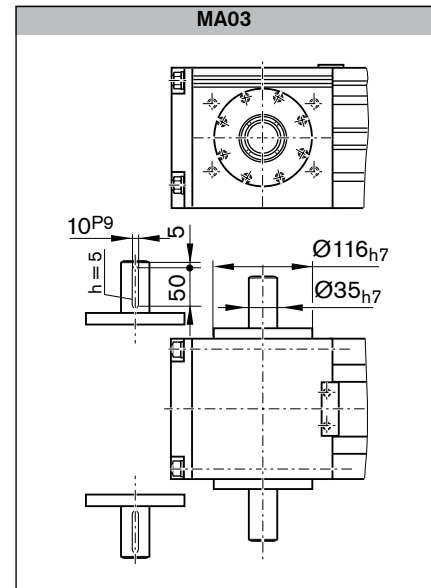
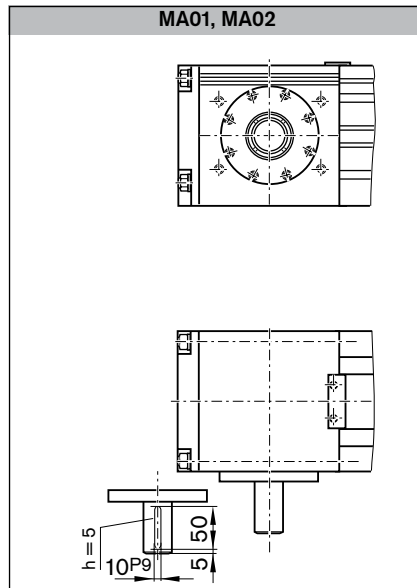
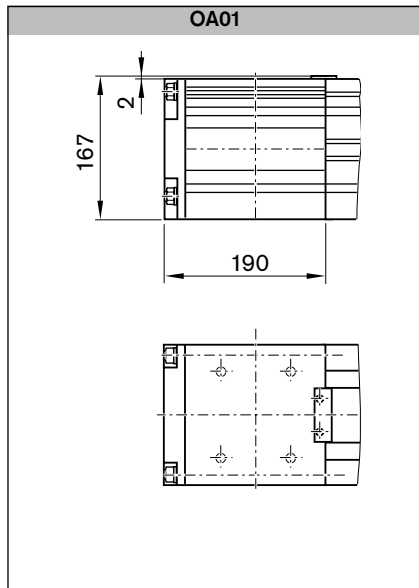
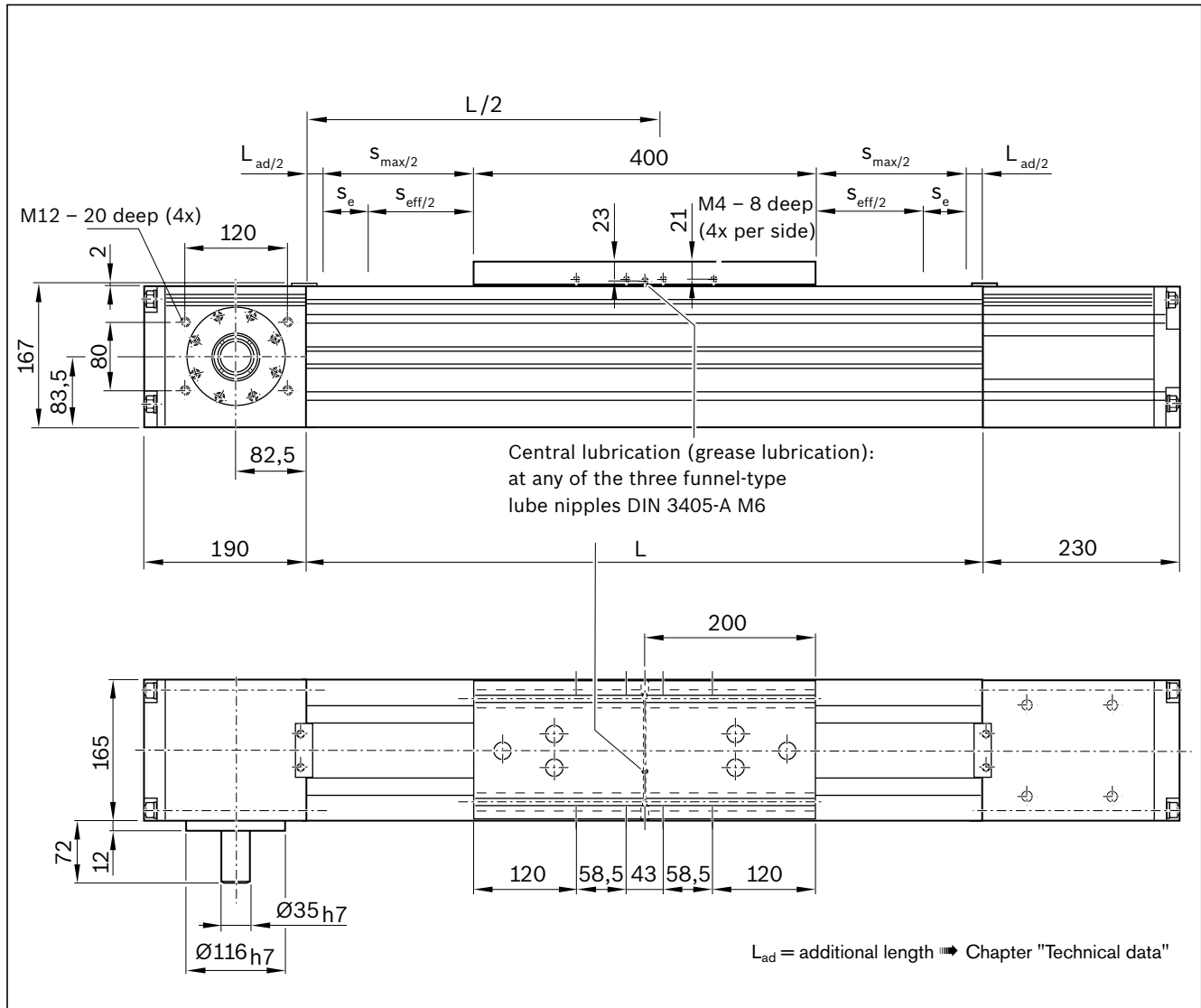

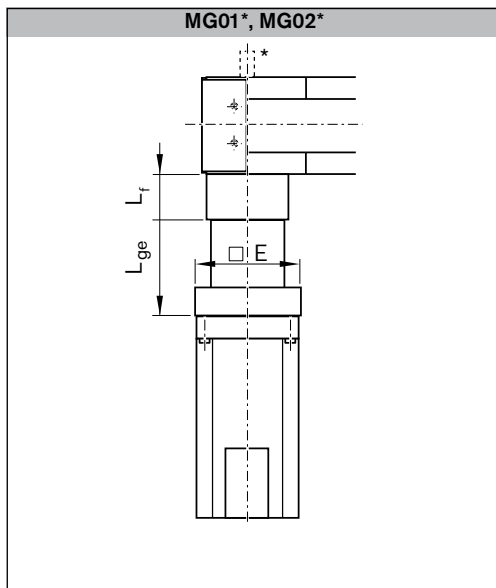
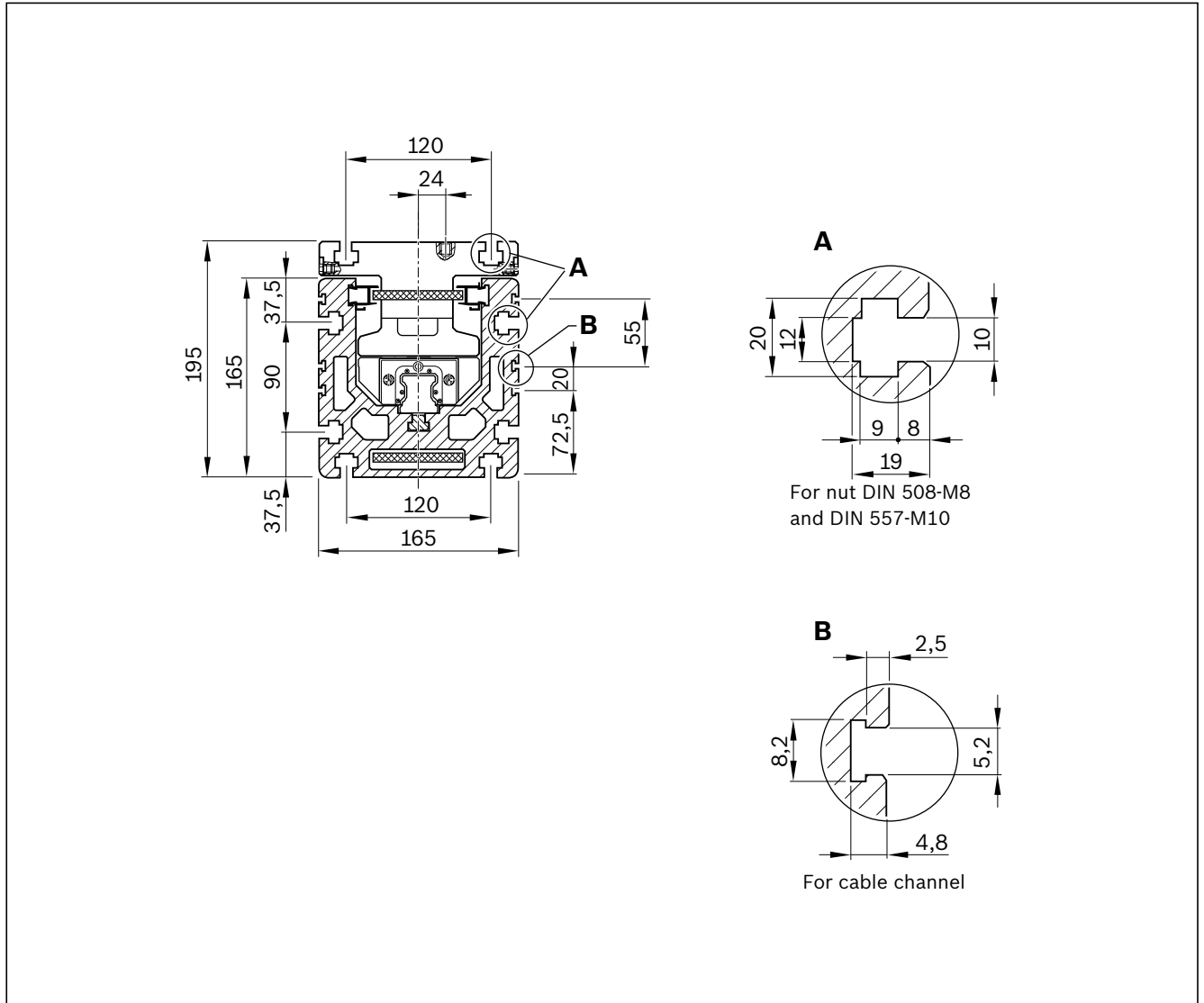

Motor code	Dimensions (mm)				
	□ E	L _r	i = 8	i = 12 ¹⁾	L _{ge} i = 16 ¹⁾
MS2N07-B1BNN	140.0	96.0	168.5	218.0	218.0
MS2N07-C1BRN					
MS2N07-D1BNN					

¹⁾ Two-stage gear

* For drive Option 31: second journal Ø 35 x 72 mm

Further information about motors ➔ "Motors" chapter

Linear modules MKR-xxx-NN-3 without drive / support axle

Product description MKR-xxx-NN-3 without drive / support axle

Features

- Ready-to-install linear modules in any length up to L_{max}
- Realization of greater lengths of up to 9,800 mm
- Extremely compact aluminum profile with integrated Rexroth ball rail system with moderate preload (preload class C1)
- Carriages made of aluminum, in two design versions, with T-slots or threaded holes and with centering holes in each case
- Protection of the guideway components by sealing strip (plastic strip on MKR-040/-065, corrosion resistant steel strip on MKR-080/-110/-140)

Further highlights

- Available in two material versions, ALST (aluminum/steel version) and ALCR (aluminum/steel hard chrome plated version)
- Center holes also in frame profile for simple combination with other linear motion systems and connection elements
- Standard with integrated solenoid switch for magnetic field sensors

Attachments

- Magnetic field sensors for easy assembly directly on the profile frame
- Switch (proximity or mechanical) cable channel, socket-plug and extension cables in the accessories program

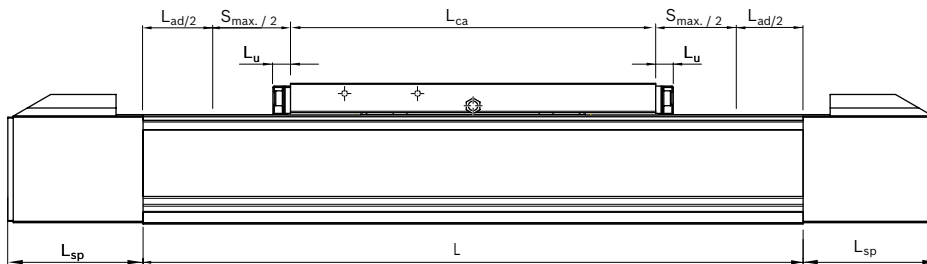
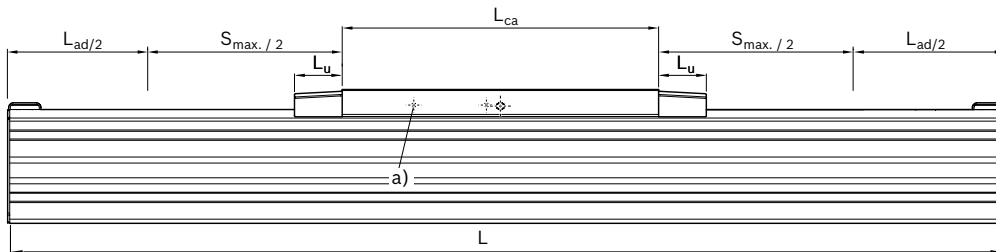

Size -040

MKR	Dimensions (mm)	
	L_{ca}	
-040-NN-3 / TT long (L)	135	
-065-NN-3 / TT long (L)	190	
-080-NN-3 / TT short (S)	190	
-080-NN-3 / TT long (L)	260	
-110-NN-3 / TT short (S)	210	
-110-NN-3 / TT long (L)	305	
-140-NN-3 / TT long (L)	370	

For further information, please refer to chapter "Linear modules MKR", dimensional drawings.

Configuration and ordering

Size -040

$s_{max.}^{1)}$ (mm)	Material pairing ²⁾	Lubrication ³⁾	Carriage			Guideway ⁴⁾		Version	Drive (without)	Cover		Documentation		
			Thread (T)	Long (L)	Number TT	Frame with or without center holes	Side sealing							
$s_{max} =$	ALST	LSS	T	L	1	021	without	0000	000	0	without	0	without	001 Standard
						024*	with			2	with			

Size -065

$s_{max.}^{1)}$ (mm)	Material pairing ²⁾	Lubrication ³⁾	Carriage			Guideway ⁴⁾		Version	Drive (without)	Cover		Documentation		
			T-slot Thread (T)	Long (L)	Number TT	Frame with or without center holes	Side sealing							
$s_{max} =$	ALST	LSS	S	L	1	021	without	0000	000	0	without	0	without	001 Standard
	ALCR					024	with			2	with	0	without	
						031	without					1	with	
						034	with							

Size -80 /-110 /-140

$s_{max.}^{1)}$ (mm)	Material pairing ²⁾	Lubrication ³⁾	Carriage			Guideway ⁶⁾		Version	Drive (without)	Cover		Documentation		
			T-slot Thread (T)	Short (S) Long (L)	Number TT	Frame with or without center holes	Side sealing							
$s_{max} =$	ALST	LSS	S	S	1	021	without	0000	000	0	without	0	without	001 Standard
	ALCR					024	with			2	with	0	without	
						031	without					1	with	
						034	with							

Index see table "Configuration and ordering data" of the corresponding MKR size

Size- 040: *Option 024: with center holes and long hole in the ground area of the frame from travel distance $s_{min} \geq 155$ mm

Linear modules MLR

Product description MLR-xxx-NN-3

Characteristic features

MLR ... : Linear modules with cam roller guide and belt drive for high-speed applications (up to 10 m/s)

⚠ Linear modules with cam roller guide to be lubricated with oil only!

Features

- Ready-to-install linear modules in any length up to L_{\max}
- Realization of greater lengths of up to 10,000 mm
- Extremely compact aluminum profile with integrated Rexroth cam roller guide with inserted cam rollers (cam rollers, set to zero-clearance via eccentric shafts)
- Aluminum carriages with T-slots and centering holes and central lubrication point (oil lubrication!)
- High-performance toothed belt (AT profile) for high drive torques with simultaneously high rigidity
- Protection of the guide components by toothed belt
- Version available without drive (support axle)

Further highlights

- Center holes also in frame profile for simple combination with other linear motion systems and connection elements
- Standard with integrated solenoid switch for magnetic field sensors
- Extensive accessories for connection and clamping elements and connecting shafts
- Nameplate with parameters for easy start-up

Attachments

- Planetary gearbox with various gear ratios
- Attachment kits for motor according to customer specification
- Servo motor
- Magnetic field sensors for easy assembly directly on the profile frame
- Switch (proximity or mechanical) cable channel, socket-plug and extension cables in the range of accessory products

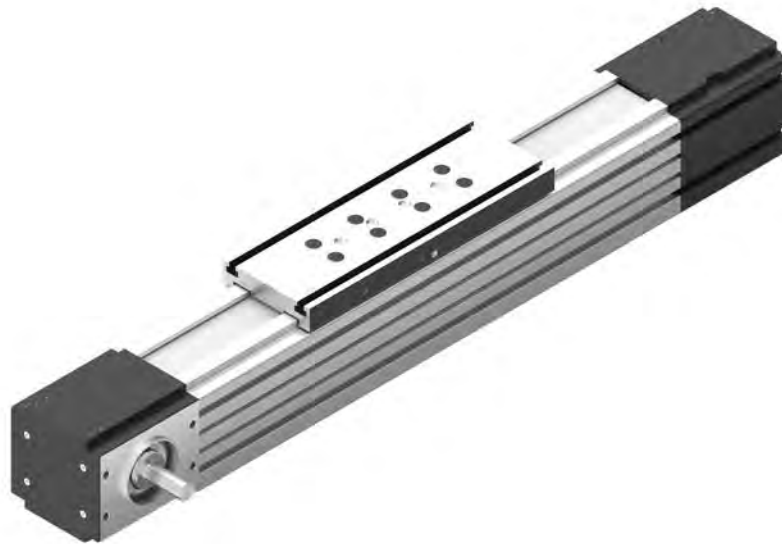

Structural design

Structural design

- 1 Drive end enclosure
- 2 Toothed belt
- 3 Carriage
- 4 Idler end enclosure
- 5 Frame

Attachments:

- 6 Mechanical switch
- 7 Cable channel
- 8 Magnetic field sensor
- 9 Switching angle
- 10 Proximity switch
- 11 Socket/plug

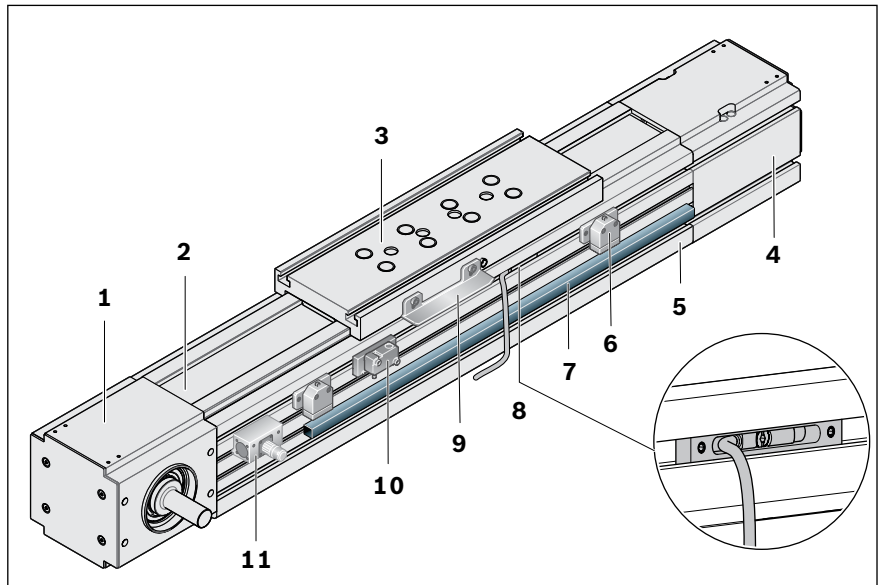

Types

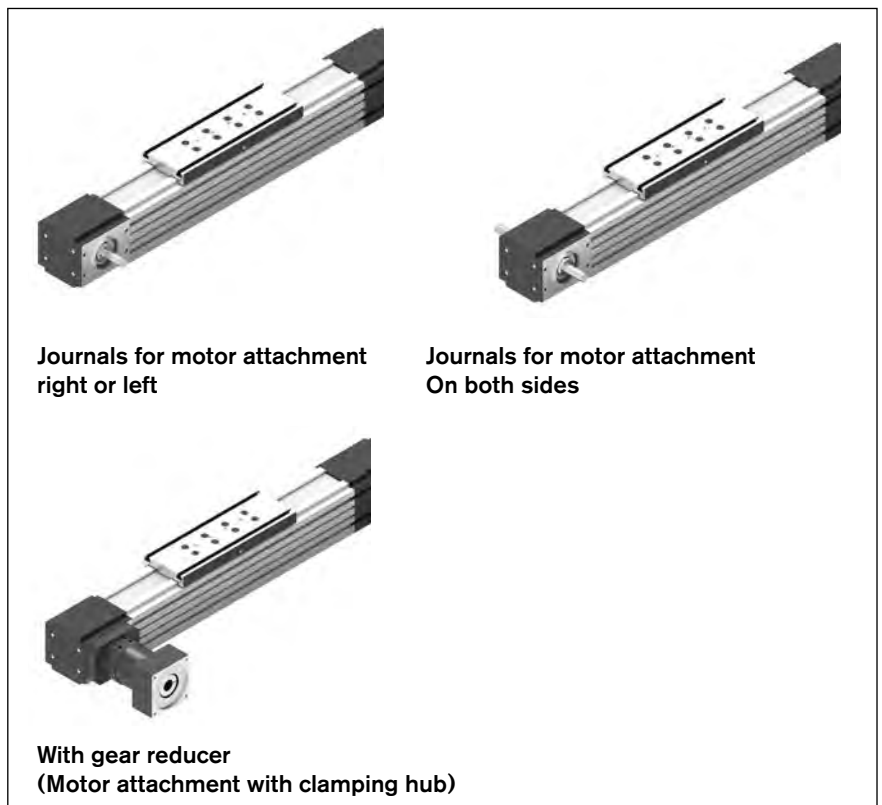

Carriage variants

Carriage (TT) with T-slots

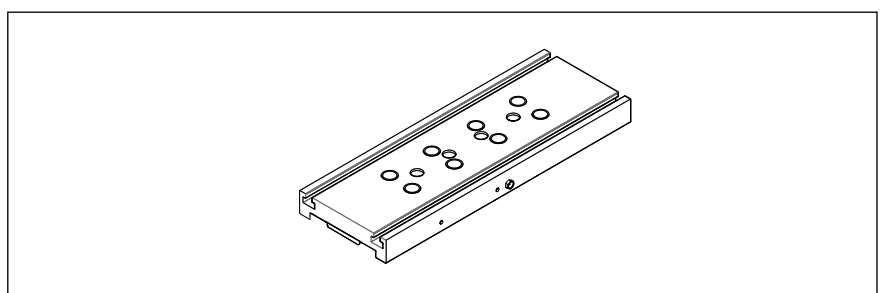

Linear modules MLR

Technical data

General technical data

Observe the "Project planning/calculation" chapter!

MLR	Carriage length L_{ca} (mm)	Dyn. characteristics				Maximum permissible loads						Moved mass of system m_{ca} (kg)
		Dynamic load capacities		Dynamic load moments		Max. permissible moments			Max. permissible forces			
		C_y (N)	C_z (N)	M_t (Nm)	M_L (Nm)	$M_{x\ max}$ (Nm)	$M_{y\ max}$ (Nm)	$M_{z\ max}$ (Nm)	$F_{y\ max}$ (N)	$F_{z1\ max}$ (N)	$F_{z2\ max}$ (N)	
-080-NN-3	190	17 150	10 050	226	316	35	158	158	2 500	1 500	1 500	1.70
-110-NN-3	305	31 000	18 200	629	1 121	49	302	302	8 000	4 800	4 800	3.50

Drive data/gear unit data

MLR	Gear type ²⁾	Gear ratio i (-)	Max. acceleration torque (at the gear output) $M_{ge}^{3)}$ (Nm)	Base frictional torque M_{Rge} (Nm)
		5	176	0.50
		10	61	0.45
-110-NN-3	PG080	3	136	0.60
		5	176	0.40
	PG120	3	184	1.20
		5	312	0.90
		10	152	0.65

MLR	Gear ratio i (-)	Max. drive torque M_P (Nm)	Feed constant u (mm/rev)	Max. speed v_{max} (m/s)	Constants mass moment of inertia				
					$k_{J\ fix}$ (kgmm ²)	$k_{J\ var}$ (kgmm)	$k_{J\ m}$ (mm ²)		
-080-NN-3	1 ⁴⁾	36.0	205.00	10.0	2 235,0	0.3187	1 064		
	1 (with keyway ⁶⁾)	36.0							
	3 ⁵⁾	12.0						68.33	5.0
	5 ⁵⁾	7.2						41.00	4.7
	10 ⁵⁾	3.6						20.50	2.4
-110-NN-3	1 ⁴⁾	100.0	290.00	10.0	8 740,0	1.2326	2 125		
	1 (with keyway ⁶⁾)	48.0							
	3 ⁵⁾	33.3						96.67	5.0
	5 ⁵⁾	20.0						58.00	5.0
	10 ⁵⁾	10.0						29.00	3.1

¹⁾ Minimum required travel curve to guarantee a reliable lubrication distribution. For operating conditions, see "Additional information".

If values are not met, please contact Bosch Rexroth.

²⁾ Planetary gearbox

³⁾ The limits of the linear motion system must not be exceeded. For more information about calculations, see the section titled "Basis of calculations".

⁴⁾ Valid for versions: 1 or 2 drive journals

⁵⁾ Valid for versions: clamping hub or clamping hub with 2nd journal

⁶⁾ Version with keyway

⁷⁾ Maximum force that can be transmitted via the teeth meshing with the belt pulley.

⁸⁾ The maximum permissible tensile load on the belt cross section (belt elasticity limit) is given here for easier comparability. This value represents the load limit in terms of plastic deformation and may not be used to calculate the maximum permissible drive torque.

Version Gearing	Constants Mass calculation		Additional length L_{ad} (mm)	Min. travel range $s_{min}^{1)}$ (mm)	Max. length L_{max} (mm)	Application point of the effective force z_1 (mm)	Planar moments of inertia	
	$k_g \text{ fix}$ (kg)	$k_g \text{ var}$ (kg/mm)					I_y (cm ⁴)	I_z (cm ⁴)
0000	0.0	0.0075	100	100	10 000	50	156	222
F010, F011, F020	3.4							
G010, G011	4.1							
0000	0.0	0.0134	70	155	10 000	64	490	697
F010, F011, F020	6.8							
G010, G011	7.4 (i=3/5); 7.6 (i=10)							

Max. drive speed $n_{ge}^{3)}$ (min ⁻¹)	Motor	Mass moment of inertia		Weight m_{ge} (kg)
		J_{ge} (kgm ²)		
7 000	MS2N06	0.0001521		3.00
	MS2N05	0.0001521		2.80
	MSM041B	0.0001521		2.00
7 000	MS2N06	0.0001290		3.00
	MS2N05	0.0001290		2.80
	MSM041B	0.0001290		2.00
7 000	MS2N06	0.0001246		3.00
	MS2N05	0.0001246		2.80
	MSM041B	0.0001246		2.00
7 000	MS2N06	0.0001520		3.00
	MS2N06	0.0001290		3.00
6 500	MS2N07	0.0004723		7.40
	MS2N07	0.0003995		7.40
	MS2N06	0.0001378		6.20
	MS2N07	0.0003744		7.40

Frictional torque M_{Rs} (Nm)	Belt pulley diameter d_3 (mm)	Belt type B_t	Max. belt drive transmission force $F_{bp}^{7)}$ (N)	Belt elasticity limit $F_{tperm}^{8)}$ (N)	Specific spring rate C_{spe} (N)	Max. acceleration a_{max} (m/s ²)
2.0	65.25	46 AT5	1 100	3 200	0.81 x 10 ⁶	50
2.9	92.31	50 AT10	2 160	8 500	2.12 x 10 ⁶	

Length calculation ➡ "Project planning/calculation" chapter
 Short product names ➡ "Abbreviations" chapter

Linear modules MLR

Technical data

General technical data

Deflection f

Observe the "General technical instructions" chapter

The graphs apply under the following conditions:

- both ends firmly fixed (200 to 250 mm per end)
- 6 to 8 screws per side
- solid mounting base

Example

Linear module MLR-080:

L = 3000 mm F = 750 N

From chart MLR-080:





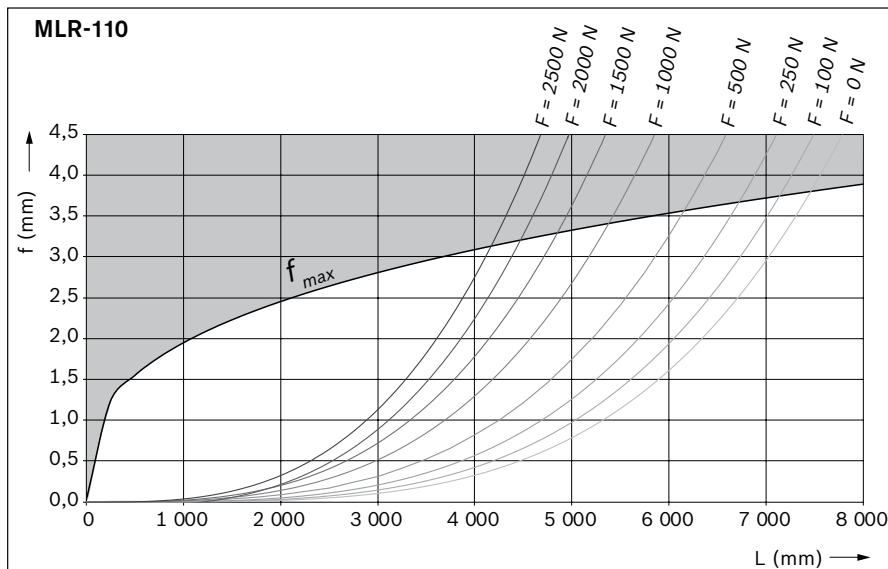
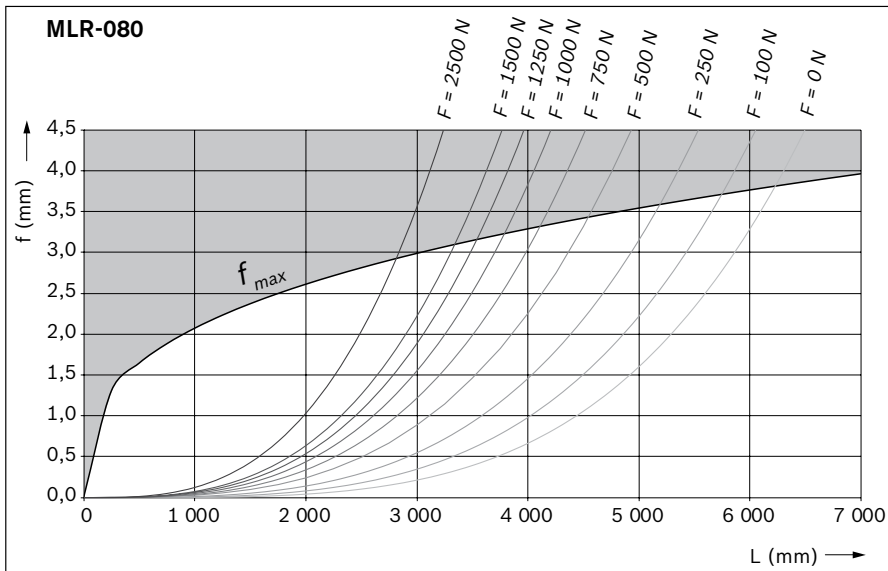

f = 1.2 mm; f_{max} = 3.0 mm

The deflection f lies well below the maximum permissible deflection f_{max}, so no additional supports are required.

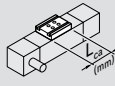
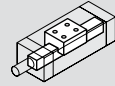
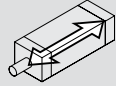

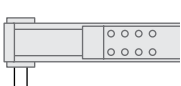
MLR-080-NN-3

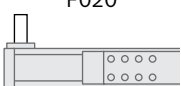
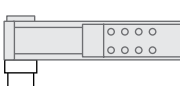
Configuration and ordering

$s_{max.}^{1)}$ (mm)	Carriage 	Guideway ²⁾ 	Version	Drive			
				Without slot	With keyway 	Clamping hub	
$s_{max} =$	001	021 without	0000				
		024 with			000		
		001 without	F010		001	003	-
			F011				
			F020		002	004	
		004 with	G010		-	-	006
			G011				016 with second journal

¹⁾ Travel distance s_{max} depends on length L and option selection Length calculation \Rightarrow "Project planning/calculation" chapter

²⁾ Frame with center holes only possible up to a length of L = 5 500 mm.

³⁾ Mounting kit with gear unit also available without motor.

⁴⁾ Further switch mounting options \Rightarrow see chapter "Switching system".

	Mounting interface ³⁾	Gearing		Motor					Sensor system ⁴⁾	Documentation
		Gear ratio	Mechanical interface	Motor code	Connector		Holding brake			
					1 cable	2 cable	with	without		
	-	-	-	-	-	-	-	-	-	
	-	-	-	-	-	-	-	-	-	000 Without sensor 140 Sensor (PNP NC) 141 Sensor (NPN NC) 142 Sensor (PNP NO) 143 Sensor (NPN NO)
	000 011	i = 1	-	-	-	-	-	-	-	
	011	i = 3 i = 5 i = 10	MSM041	MSM041B-0300	-	2				000 090 180 270
			MS2N05	MS2N05-B0BTN						
				MS2N05-C0BTN						
				MS2N05-D0BRN	1	2	Y	N		
			MS2N06	MS2N06-B1BNN						
				MS2N06-D1BNN						

Version	Motor connector position			
	0°	90°	180°	270°
G010/G011	000	090 ★	180	270

★ Standard delivery (connector position)

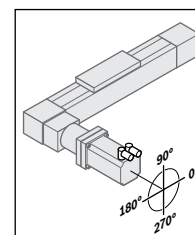





001 standard; 002 frictional torque; 005 positioning accuracy

Linear modules MKR

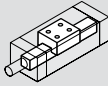
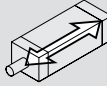
MLR-110-NN-3

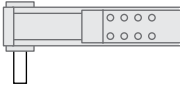
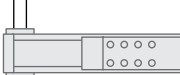
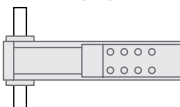
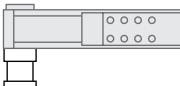
Configuration and ordering

s _{max.} ¹⁾ (mm)	Carriage  T-slot L _{ca} = 305 (mm)	Guideway ²⁾  Frame with or without center holes	Version	Drive		
				Without slot	With keyway 	Clamping hub
s _{max} =	001	021 without	0000 	000		
		024 with				
		001 without	F010 	001	003	
			F011 			
			F020 	002	004	
		004 with	G010 			006
						016 with second journal
			G011 		008	
						018 with second journal

1) Travel distance s_{max} depends on length L and option selection. Length calculation ➡ "Project planning/calculation" chapter

2) Frame with center holes only possible up to a length of L = 5 500 mm.

3) Mounting kit with gear unit also available without motor.

4) Further switch mounting options ➡ see chapter "Switching system".

	Mounting interface ³⁾	Gearing		Motor					Sensor system ⁴⁾	Documentation	
		Gear ratio	Mechanical interface	Motor code	Con- nector		Holding brake				Motor connector position
					1 cable	2 cable	with	without			
	-	-	-	-	-	-	-	-	-	Quantity: 1 - 6	
	-	-	-	-	-	-	-	-	-		
	000 011	i = 1	-	-	-	-	-	-	-		
	011	i = 3 i = 5	MS2N06	MS2N06-B1BNN MS2N06-D1BNN	1	2	Y	N	000 090 180 270		
	000 012	i = 1	-	-	-	-	-	-	-		
	012	i = 10 i = 3 i = 5 i = 10	MS2N06 MS2N07	MS2N06-B1BNN MS2N06-D1BNN MS2N07-B1BNN MS2N07-C1BRN MS2N07-D1BNN	1	2	Y	N	000 090 180 270		

000 Without sensor
 144 Sensor (PNP NC)
 145 Sensor (NPN NC)
 146 Sensor (PNP NO)
 147 Sensor (NPN NO)

001 standard; 002 frictional torque; 005 positioning accuracy

Version	Motor connector position			
	0°	90°	180°	270°
G010/G011	000	090 ★	180	270

★ Standard delivery (connector position)

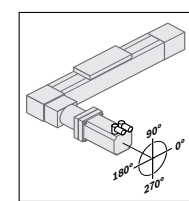

Dimensional drawings MLR-080/-110/-NN-3

Frame

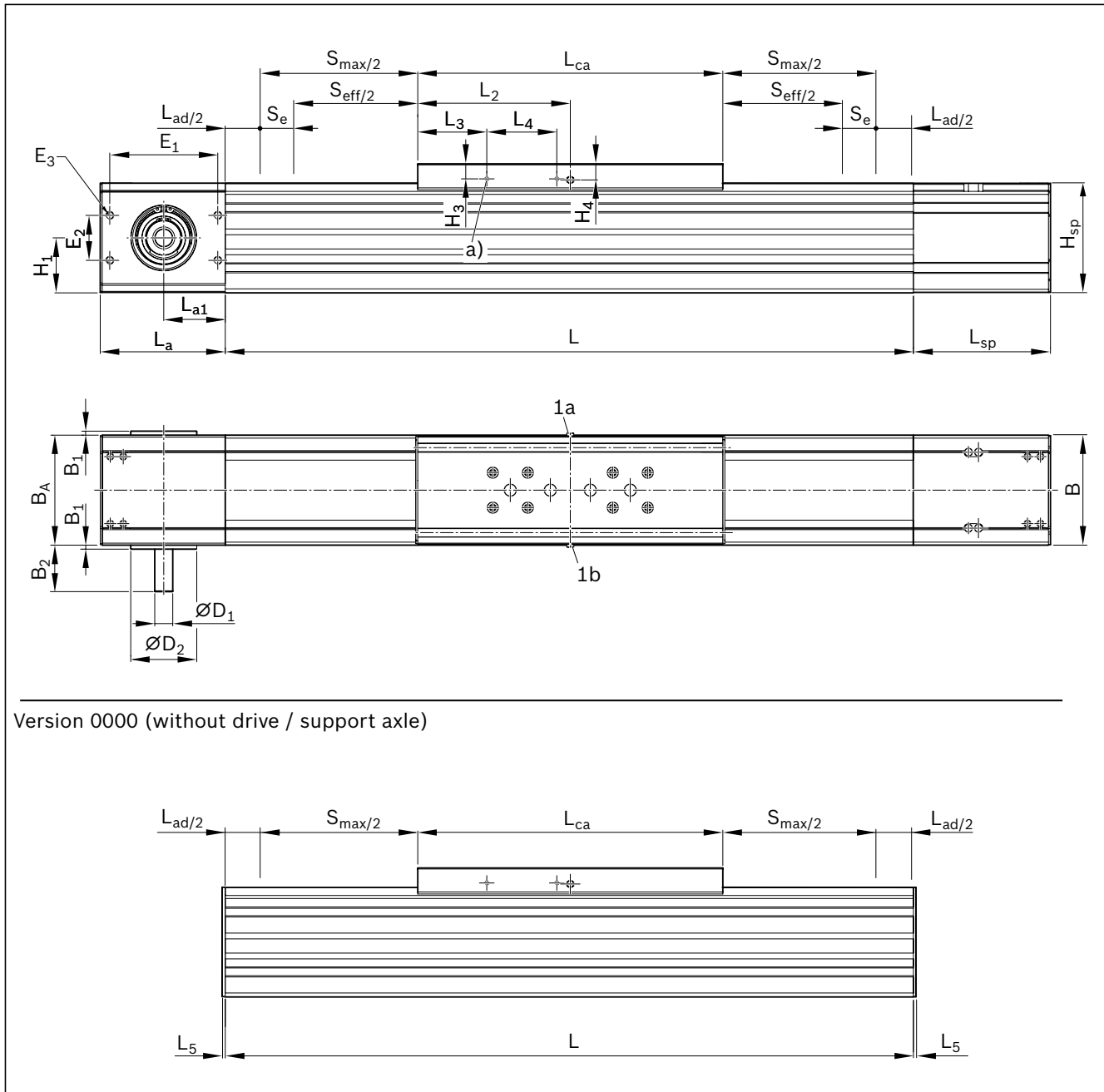

Version 0000 (without drive / support axle)

MLR	Dimensions (mm)																					
	B	BA	B1	B2	B3	BS	Ø D1 h7	Ø D2 h7/H7	E1	E2	E3	H	H1	H3	H4	Hsp	Lca	L2	L3	L4	L5	
-080-NN-3	80	80	10	53.0	53.0	-	18	66	84	39	M6-10 deep	100	41.0	11.5	12.5	90	190	145.0	15			
-110-NN-3	110	110	4	46.5	46.5	85	18	66	108	45	M8-18 deep	129	55.0	15.0	15.0	115	305	152.5	69	70	2	

L_{ad} = additional length → Chapter "Technical data"

See following pages for dimension drawings for carriages and motor attachment.

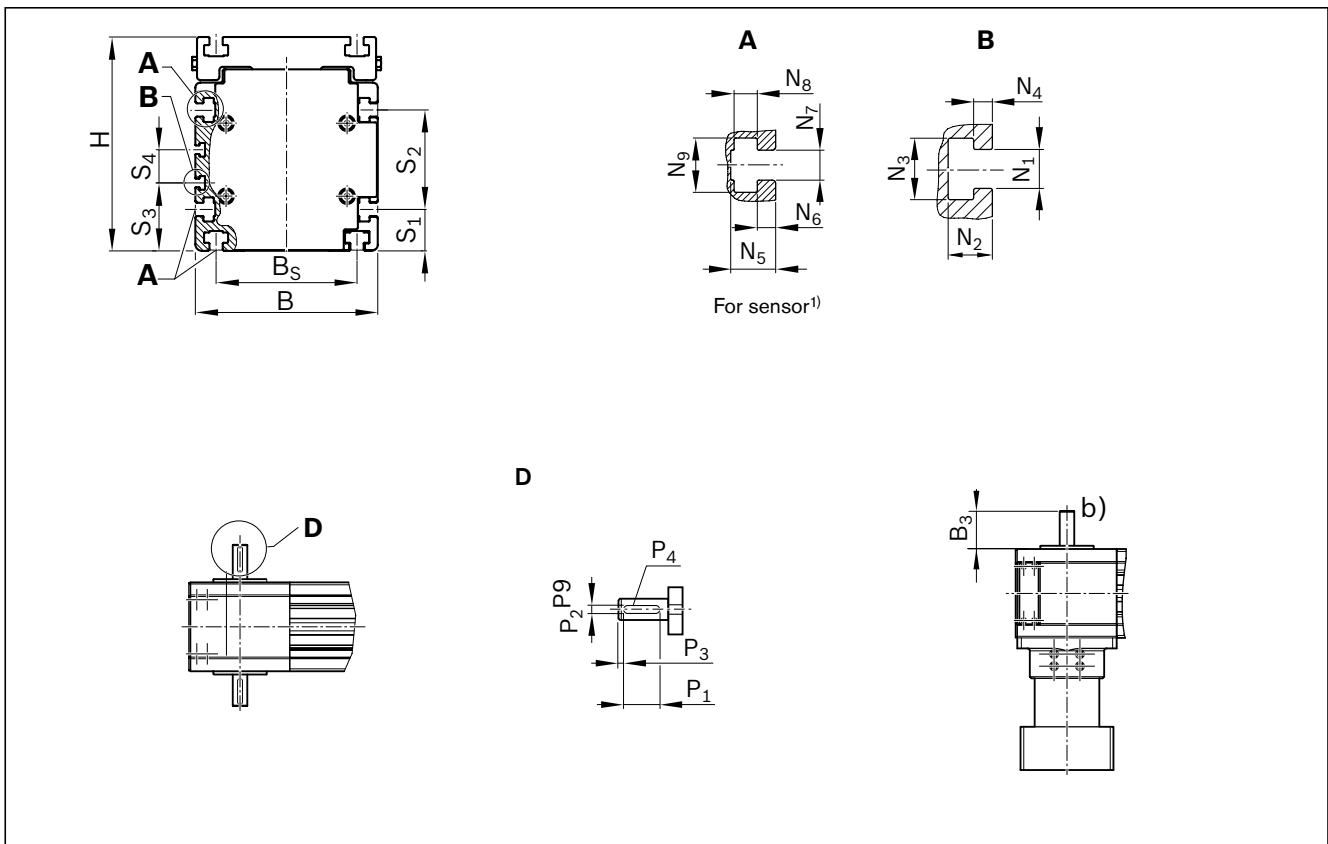
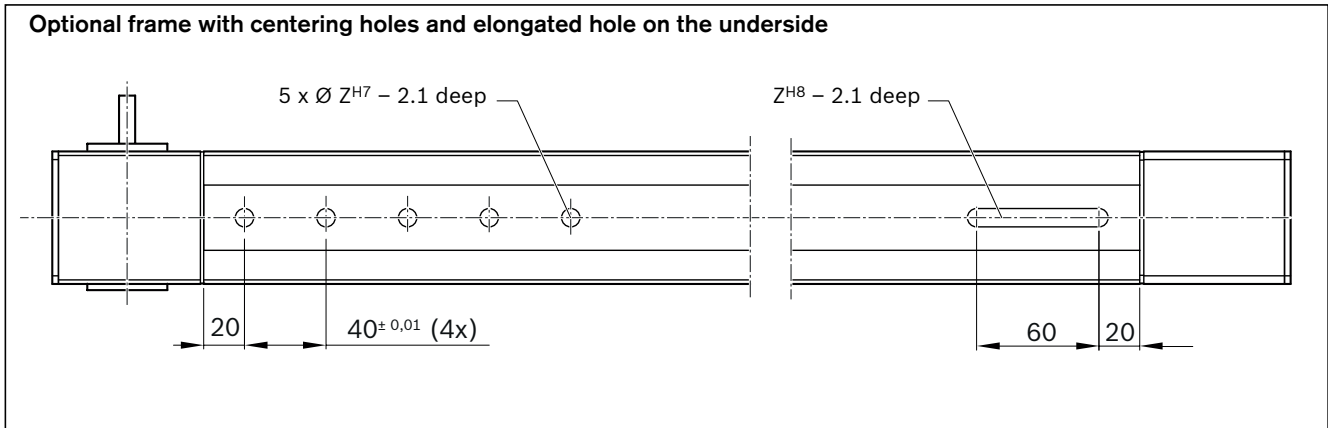

L_a	L_{a1}	L_{sp}	Sliding block	N_1	N_2	N_3	N_4	N_5	N_6	N_7	N_8	N_9	P_1	P_2 P_9	P_3	P_4 deep	S_1	S_2	S_3	S_4	Z
102	50.0	102	DIN557-M5	5.2	5.9	8.2	2.5	8.5	2.5	5.2	5.0	9.0	32	6	2	3.5	18	45	42.5	-	9
125	61.5	137	DIN508-M6	5.2	5.9	8.2	2.5	12.0	4.9	8.0	6.2	14.5	32	6	2	3.5	25	60	41.0	20	12

¹⁾ deviating from MKR; see sensor mounting

1a / 1b lube connection for guideway: lubrication on either of the two connections.
(Funnel-type lube nipple DIN 3405-A M6)

- a) Fastening thread M4-8 deep (4x) for switch bracket
- b) for drive option: Clamping hub with second journal ($\varnothing D_1 \times B_3$)

MLR-080/-110/-NN-3

Carriage dimension drawings

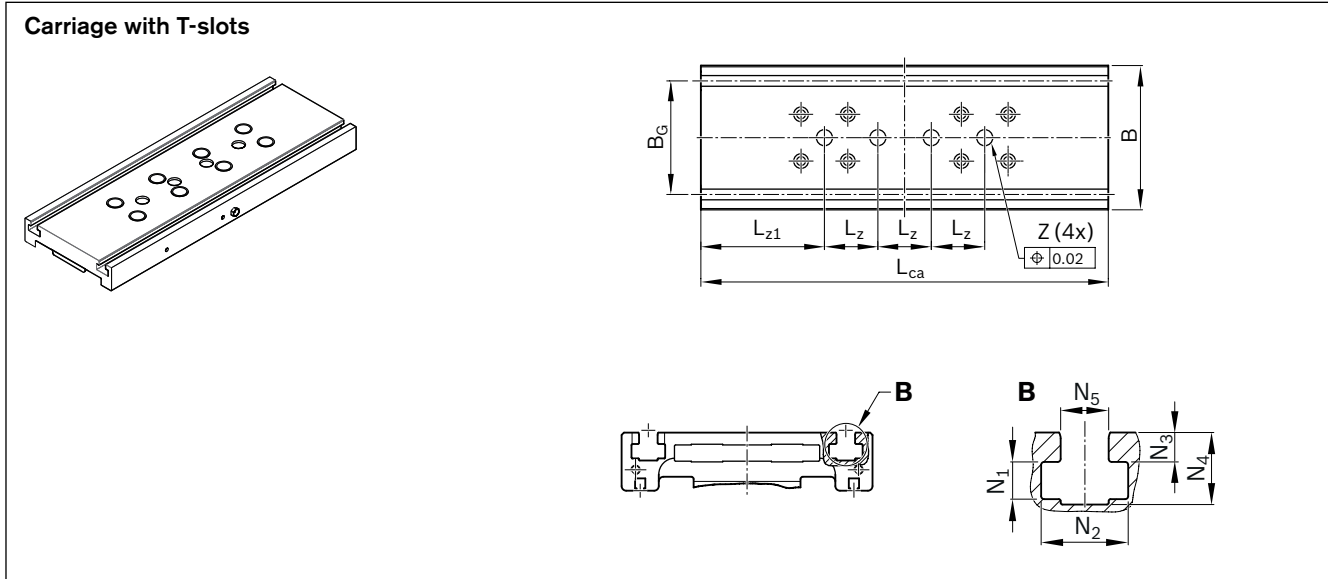

MKR	Dimensions (mm)					Sliding block	N ₁	N ₂	N ₃	N ₄	N ₅	ØZ
	B	B _G	L _{ca}	L _z	L _{z1}							
-080-NN-3	78	60	190	40	35.0	DIN557-M5	5.0	9.0	2.5	8.5	5.2	9H7-2.1 deep
-110-NN-3	108	85	305	40	92.5	DIN508-M6	6.2	14.5	4.9	12.0	8.0	12H7-2.1 deep

Motor attachment dimension drawings

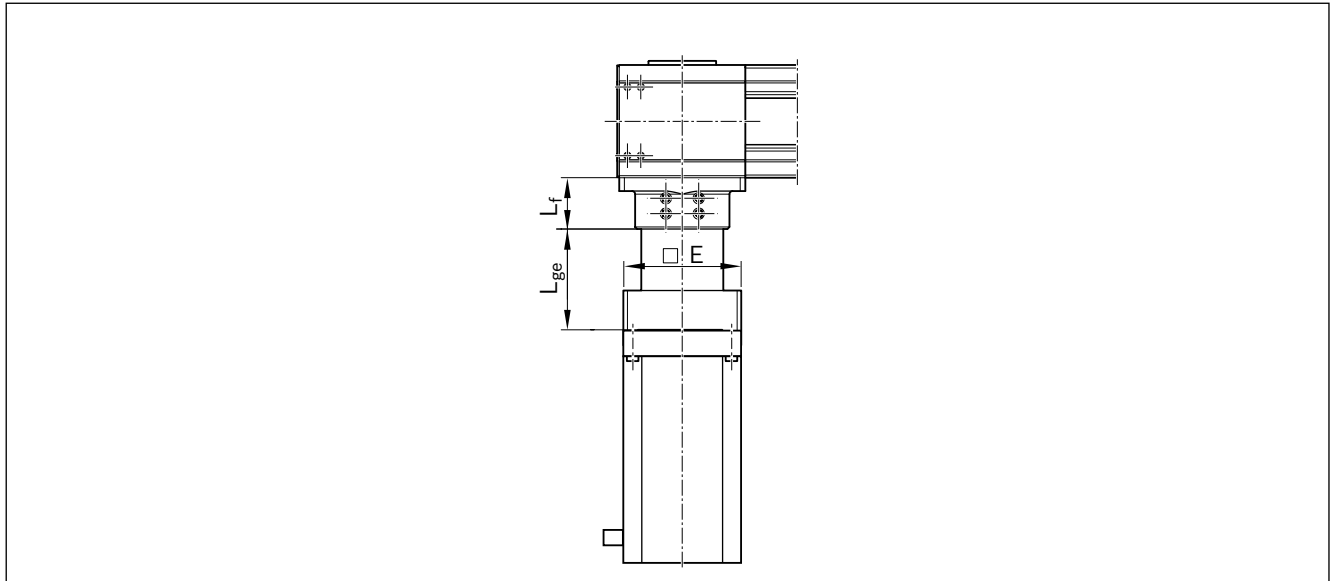

MKR	Gear ratio i	Motor code	Dimensions (mm)		
			E	L_f	L_{ge}
-080-NN-3	3/5/10	MSM041B-0300	80	54.0	98.5
		MS2N05-BOBTN	100		101.5
		MS2N05-COBTN			113.5
		MS2N05-DOBRN			
		MS2N06-B1BNN	115		113.5
MS2N06-D1BNN					
-110-NN-3	3 / 5	MS2N06-B1BNN	115	50.0	113.5
		MS2N06-D1BNN			
	10	MS2N06-B1BNN	115	62.0	131.5
		MS2N06-D1BNN			
	3/5/10	MS2N07-B1BNN	140	62.0	147.0
		MS2N07-C1BRN			
	MS2N07-D1BNN				

Further information about motors ➔ "Motors" chapter

Linear modules MKR-145

Product description MKR-145-NN-3

Features

- Ready-to-install linear modules in any length up to L_{max}
- Realization of greater lengths of up to 6,000 mm
- Rigid aluminum profile frame with Rexroth ball rail system with cover strip
- Ball runner block with moderate preload (preload class C1)
- Aluminum carriages with T-slots and centering holes
- Economical maintenance thanks to the one-point lubrication feature (grease lubrication or oil lubrication) from both sides via the carriage
- High-performance toothed belt (AT profile) for high drive torques with simultaneously high rigidity

Further highlights

- Center holes also in frame profile for simple combination with other linear motion systems and connection elements
- Standard with integrated solenoid switch for magnetic field sensors
- Extensive accessories for connection and clamping elements and connecting shafts
- Nameplate with parameters for easy start-up

Attachments

- Planetary gearbox with various gear ratios
- Attachment kits for motor according to customer specification
- Servo motor
- Magnetic field sensors for easy assembly
- Switch (proximity or mechanical) cable channel, socket-plug and extension cables in the accessories program



Structural design

Structural design

- 1 Drive end enclosure
- 2 ball rail systems
- 3 Toothed belt
- 4 Carriage
- 5 Idler end enclosure
- 6 Frame

Attachments:

- 7 Magnetic sensor
- 8 Cable channel
- 9 Switching angle
- 10 Proximity switch
- 11 Mechanical switch
- 12 Socket/plug

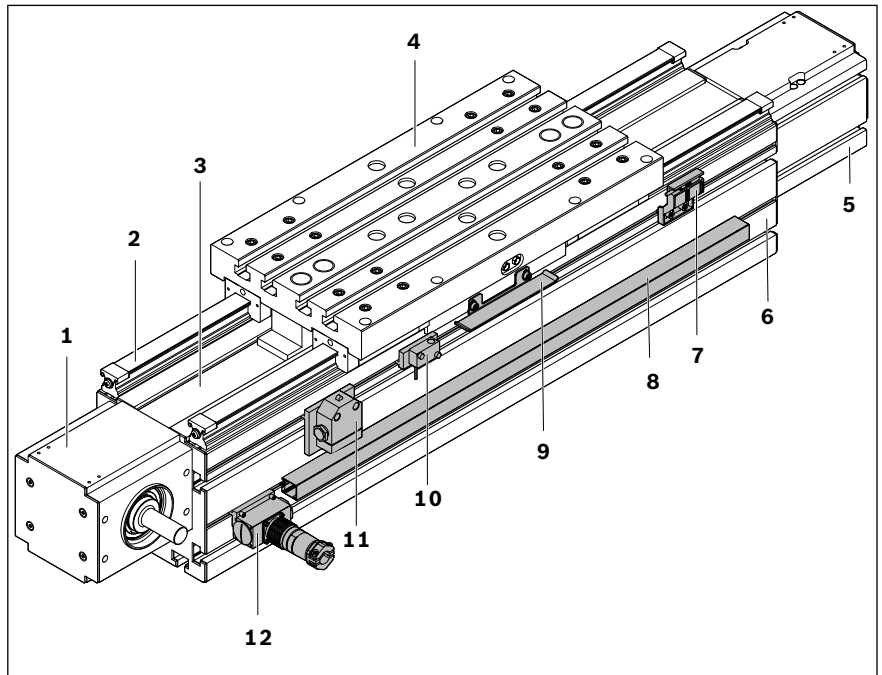

Types

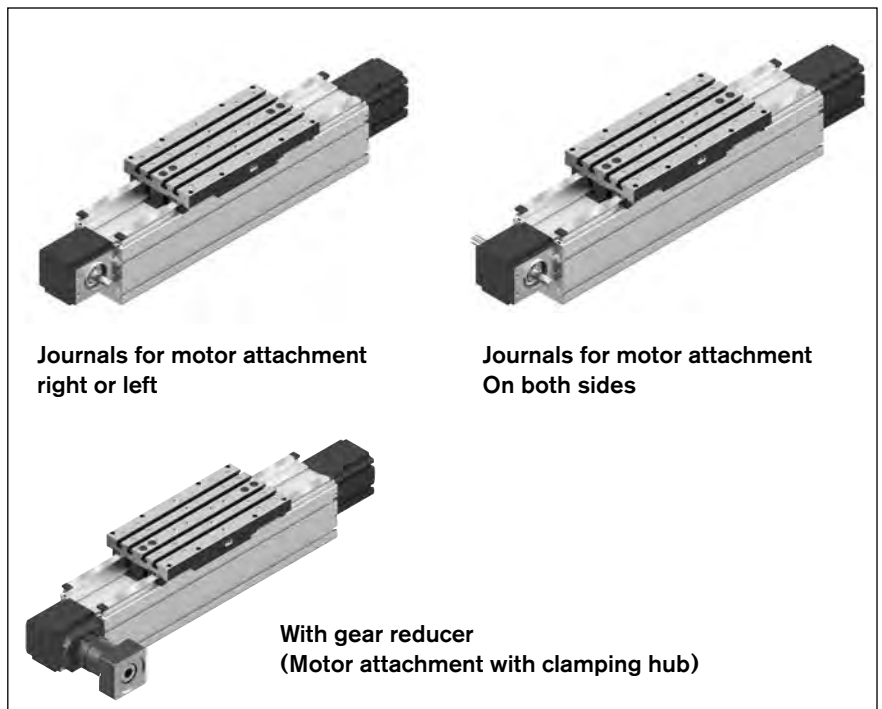

Carriage variants

Carriage (TT) with T-slots

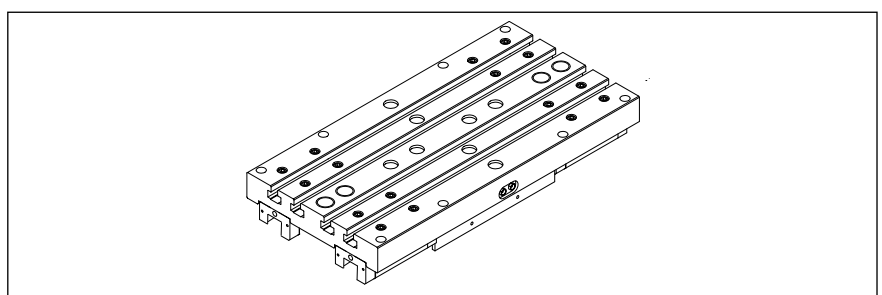

Technical data

General technical data

Read the sections titled "Calculation" and "General technical instructions".

MKR	Carriage length L_{ca} (mm)	Dyn. characteristics			Maximum permissible loads						Moved mass of system m_{ca} (kg)
		Dynamic load capacities C_{gw} (N)	Dynamic load moments M_t (Nm) M_L (Nm)		Max. permissible moments $M_{x\ max}$ (Nm) $M_{y\ max}$ (Nm) $M_{z\ max}$ (Nm)			Max. permissible forces $F_{y\ max}$ (N) $F_{z1\ max}$ (N) $F_{z2\ max}$ (N)			
MKR-145-NN-3	400	121 190	7 030	17 630	2 500	6 300	7 200	49 400	49 400	43 200	9.80

Gear data

Gear type ²⁾	Gear ratio i (-)	Max. acceleration torque (at the gear output) M_{ge} ³⁾ (Nm)	Base frictional torque M_{Rge} (Nm)	Max. drive speed n_{ge} ³⁾ (min ⁻¹)	Motor type	Mass moment of inertia J_{ge} (kgm ²)	Weight m_{ge} (kg)
PG080	3	136	0.60	7 000	MS2N06	0.0001520	3.00
	5	176	0.40		MS2N06	0.0001290	3.00
PG120	3	184	1.20	6 500	MS2N07	0.0004723	7.40
	5	312	0.90		MS2N07	0.0003995	7.40
	10	152	0.65		MS2N06	0.0001378	6.20
					MS2N07	0.0003744	7.40

¹⁾ Minimum required travel curve to guarantee a reliable lubrication distribution. For operating conditions, see the "Additional information" chapter. If values are not met, please contact Bosch Rexroth.

²⁾ Planetary gearbox

³⁾ The limits of the linear motion system must not be exceeded. For more information about calculations, see the section titled "Basis of calculations".

⁴⁾ Valid for versions: 1 or 2 drive journals

⁵⁾ Valid for versions: clamping hub or clamping hub with 2nd journal

⁶⁾ Version with keyway

⁷⁾ Maximum force that can be transmitted via the teeth meshing with the belt pulley.

⁸⁾ The maximum permissible tensile load on the belt cross section (belt elasticity limit) is given here for easier comparability. This value represents the load limit in terms of plastic deformation and may not be used to calculate the maximum permissible drive torque.

Version gear unit	Constants mass calculation		Additional length L_{ad} (mm)	Min. travel range $s_{min}^{1)}$ (mm)	Max. length L_{max} (mm)	Application point of the effective force z_1 (mm)	Planar moments of inertia	
	$k_g \text{ fix}$ (kg)	$k_g \text{ var}$ (kg/mm)					I_y (cm ⁴)	I_z (cm ⁴)
F010, F011, F020	11.5	0.0357	40	80	6 000	50.5	3 055	1 965
G010, G011	11.8							

Drive data

Gear ratio i (-)	Max. drive torque M_P (Nm)	Feed constant u (mm/rev)	Max. speed v_{max} (m/s)	Constants - mass moment of inertia			Frictional torque M_{Rs} (Nm)	Belt pulley diameter d_3 (mm)	Belt type B_t	Max. belt drive transmission force $F_{bp}^{7)}$ (N)	Elasticity limit $F_{tperm}^{8)}$ (N)	Specific spring rate c_{spe} (N)	Max. acceleration a_{max} (m/s ²)
				$k_{J \text{ fix}}$ (kgmm ²)	$k_{J \text{ var}}$ (kgmm)	$k_{J \text{ m}}$ (mm ²)							
1 ⁴⁾	100.0	290.00	5.0	22 554	1.2326	2 125	6.7	92.31	50 AT10	2 160	8 500	2.12×10^6	50
1 with keyway ⁶⁾	48.0												
3 ⁵⁾	33.3												
5 ⁵⁾	20.0												
10 ⁵⁾	10.0												

Length calculation ➡ "Project planning/calculation" chapter
 Short product names ➡ "Abbreviations" chapter

Deflection

The diagram applies to: both ends firmly fixed (approx. 350 mm per side), 6 to 8 screws per side, fixed substructure

Example

Linear module MKR-145: $L = 4,000 \text{ mm}$; $F = 2,000 \text{ N}$; From diagram: $f = 0.43 \text{ mm}$; $f_{max} = 3.1 \text{ mm}$
 The deflection f lies well below the maximum permissible deflection f_{max} , so no additional supports are required.

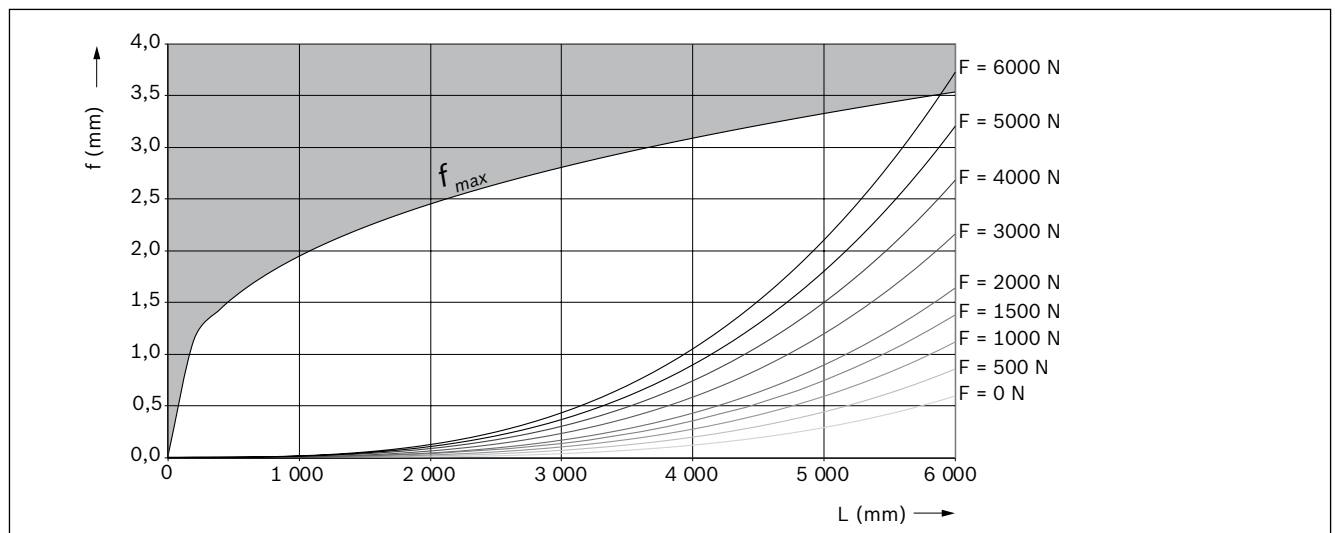

MKR-145-NN-3

Configuration and ordering

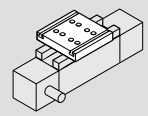
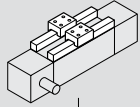
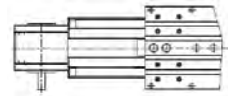
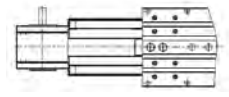
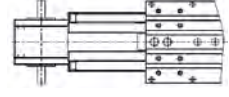
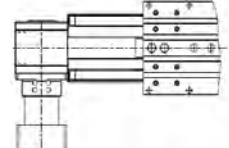
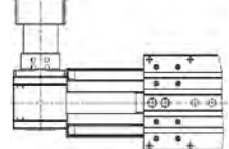
$s_{max.}^{1)}$ (mm)	Material pairing ²⁾	Lubrication ³⁾ 	Carriage  $L_{ca} = 400 \text{ mm}$	Guideway ⁴⁾ 		Version
				Frame without center holes	Frame with center holes	
$s_{max} =$	ALST	LSS	011	001	004	F010 
		LCF	021			F011 
		LCO	031			F020 
		LPG	041			G010 
	ALCR	LSS	016	011	014	G011 
		LCF	026			
		LCO	036			
		LPG	046			

¹⁾ Travel distance s_{max} depends on length L and option selection Length calculation \Rightarrow "Project planning/calculation" chapter

²⁾ Material pairing \Rightarrow see chapter "Product description MKR-xxx-NN-3".

³⁾ Lubrication \Rightarrow see chapter "Additional Information".

⁴⁾ Frame with center holes only possible up to a length of L = 5 500 mm.

⁵⁾ Mounting kit with gear unit also available without motor.

⁶⁾ Further switch mounting options \Rightarrow see chapter "Switching system".

	Drive			Mounting interface ⁵⁾	Gearing		Motor					Cover		Sensor system ⁶⁾	Documentation
	Without slot	with keyway	Clamping hub		Gear ratio	Mechanical interface	Motor code	1 cable	2 cable	with	without	Motor connector position	Cover		
	001	003	-	-	-	-	-	-	-	-	-	0 without	0 without	000 Without sensor 125 sensor (PNP NC); 126 sensor (NPN NC) 127 sensor (PNP NO); 128 sensor (NPN NO)	001 standard; 002 frictional torque; 005 positioning accuracy
	002	004	-	-	-	-	-	-	-	-	-	2 with	0 without		
	-	-	006	000 011	i = 1	-	-	-	-	-	-	2 with	0 without		
			016 With second journal	011	i = 3 i = 5	MS2N06	MS2N06-B1BNN	1	2	Y	N				
	-	-	008	000 012	i = 1	-	-	-	-	-	-	1 with	1 with		
			018 With second journal	012	i = 3 i = 5 i = 10	MS2N07	MS2N06-B1BNN	1	2	Y	N			000 090 180 270	
							MS2N07-B1BNN								

Version	Motor connector position			
	0°	90°	180°	270°
G010/G011	000	090 ★	180	270

★ Standard delivery (connector position)

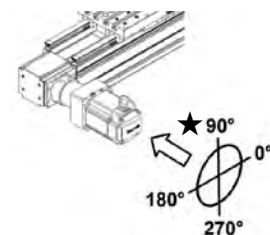

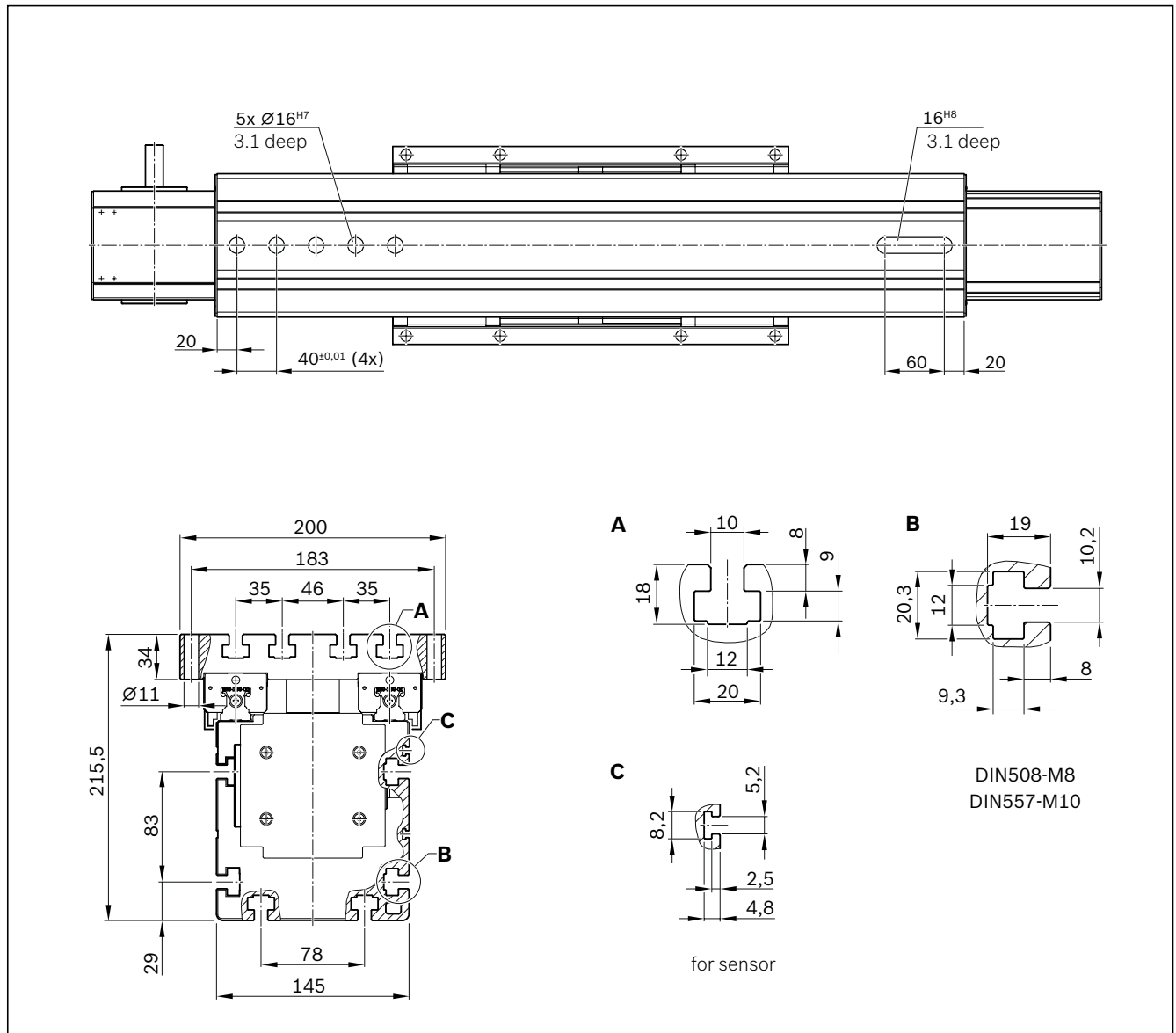

MKR	Gear ratio i	Motor	Motor code	Dimensions (mm)			
				□ E	L _F	L _G	
-145-NN-3	3 / 5	MS2N06	MS2N06-B1BNN	115	50.0	113.5	
			MS2N06-D1BNN				
	10	MS2N06	MS2N06-B1BNN			62.0	131.5
			MS2N06-D1BNN				
	3/5/10	MS2N07	MS2N07-B1BNN		140	147.0	
			MS2N07-C1BRN				
MS2N07-D1BNN							

Further information about motors ➔ "Motors" chapter

Attachments and accessories

Fastener

General notes

The linear modules are mounted using various fastening elements:

- Clamping fixtures
- Sliding blocks for size -110 and up
- Square nuts
- Spring nuts
- Screws for T-slots as per DIN 787 (without figure).

Length depends on base.

When mounting linear modules, please note the maximum tightening torques listed in the table.

Size	A (mm)	B (mm)	C (mm)
-040	52.2	65.5	-
-065	81.0	95.0	-
-080	96.0	110.0	-
-110	132.0	150.0	85.0
-140	167.0	193.0	105.0
-145	172.0	198.0	78.0
-165	192.0	218.0	120.0

See "Robotic Erector System for linear module" for additional mounting accessories for connecting linear modules.

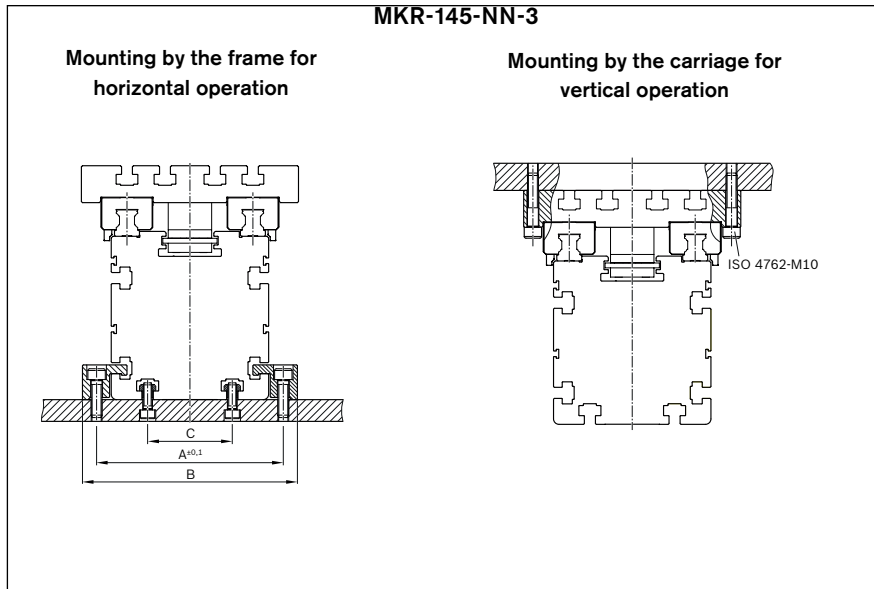
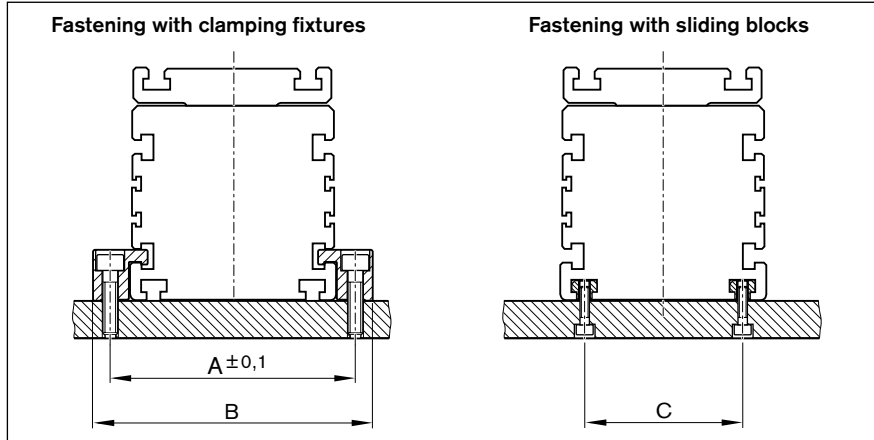

**⚠ Do not mount or support the linear module by the end block, end enclosure or end plate!
The frame is the load-bearing part!**

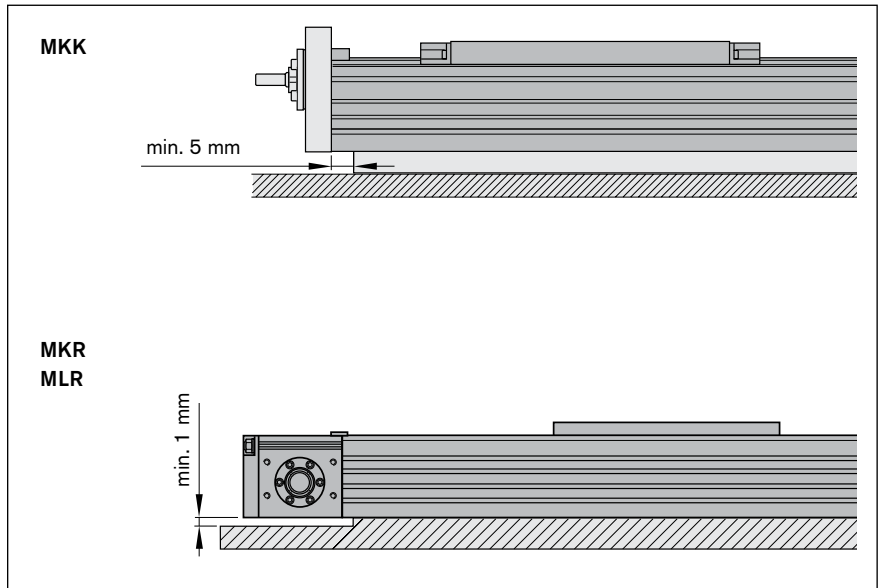

Clamping fixtures

Recommended number of clamping fixtures for linear modules -040:

- Type 1: 6 pieces per side/m
- Type 2: 4 pieces per side/m
- Type 3: 3 pieces per side/m

Recommended number of clamping fixtures for linear modules -065 and up:

- Type 2: 3 per meter and side

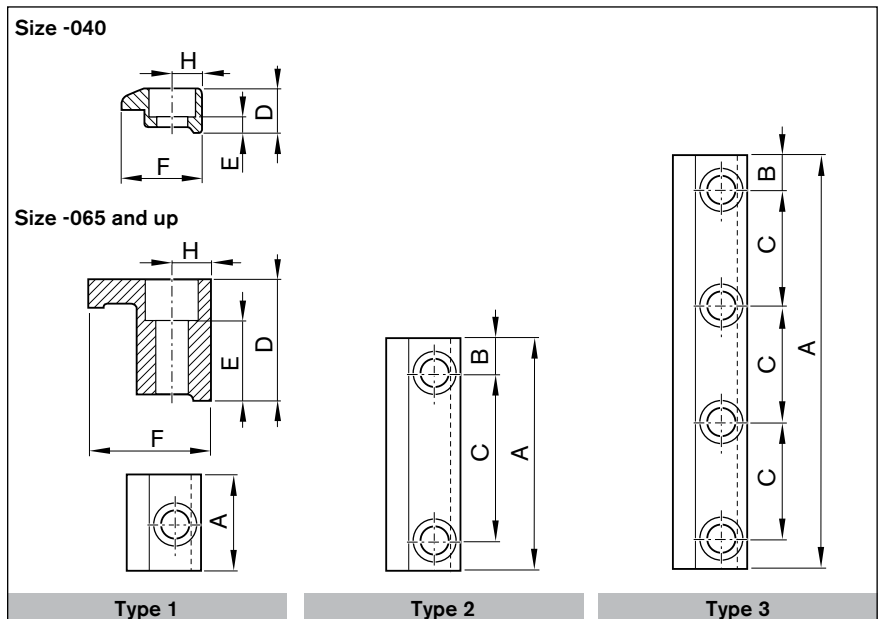

Size	Countersink ISO 4762 for	Type	Quantity holes N	Dimensions (mm)							Material number
				A	B	C	D	E	F	H	
-040	M5	1	1	22	-	-	10.0	4.8	15	6.5	R141901001
			2	57	8.5	40					R141901043
			3	77	8.5	20					R141901044
-065	M6	2	2	78	14.0	50	20.0	11.5	20	7.0	R117519024
-080	M6			78	14.0	50	20.0	11.5	20	7.0	R117519024
-110	M8			108	19.0	70	27.5	16.5	29	9.0	R117529026
-140	M10			163	29.0	105	40.5	27.0	41	13.0	R117539014
-165	M10			163	29.0	105	40.5	27.0	41	13.0	R117539014
-145	M10			163	29.0	105	32.0	18.5	41	13.0	R117529044

Mounting and fastening elements

Centering rings

The centering ring serves as a positioning aid and for positive locking when mounting customer attachments to the carriage and the frame. It creates a positive-locking connection with good reproducibility.
Material: Steel

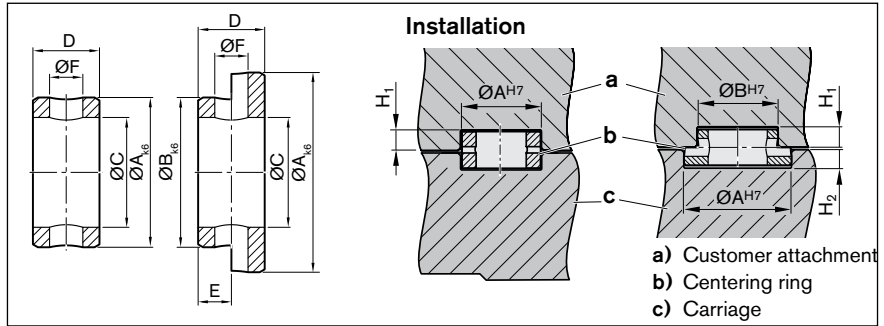

Ø Size (mm)	Dimensions (mm)								Material number
	A	B	C ±0.1	D -0.2	E +0.2	ØF	H ₁ +0.2	H ₂ +0.2	
5	5	-	3.4	3.0	-	1.6	1.6	-	R039660542
7	7	-	5.5	3.0	-	1.6	1.6	-	R039660543
9	9	-	6.6	4.0	-	2.0	2.1	-	R039660544
12	12	-	9.0	4.0	-	2.0	2.1	-	R039660545
16	16	-	11.0	6.0	-	3.0	3.1	-	R039660546
7 - 5	7	5	3.4	3.0	1.5	1.6	1.6	1.6	R039660547
9 - 5	9	5	3.4	3.5	1.5	1.6	2.1	1.6	R039660548
9 - 7	9	7	5.5	3.5	1.5	1.6	2.1	1.6	R039660549
12 - 9	12	9	6.6	4.0	2.0	2.0	2.1	2.1	R039660550
16 - 12	16	12	9.0	5.0	2.0	2.0	2.1	3.1	R039660551

Sliding blocks

Size	Dimensions (mm)							Material number
	A	B	C	D	E	F	G	
-110	13	6.0	10	8	-	13	M6 (1x)	R344700101 ^{*)}
						9	M6 (2x)	R039175003 ^{*)}
-140 / -145 -165	15	6.0	12	10	-	15	M6 (1x)	M6: R344700301 ^{*)}
							M8 (1x)	M8: R344700201 ^{*)}
						15	M8 (2x)	R039175004 ^{*)}
	19	8.8	12	10	-	19	M10 (1x)	R344700601

^{*)} Profile as per DIN 508

Square nuts

Size	Dimensions (mm)			Material number
	A	B	C	
-065 / -080	8	4	M5	R913001655 per DIN 557
-110	13	4	M8	R344200301 per DIN 562
-140 / -145 / -165	16	8	M10	R344200200 per DIN 557

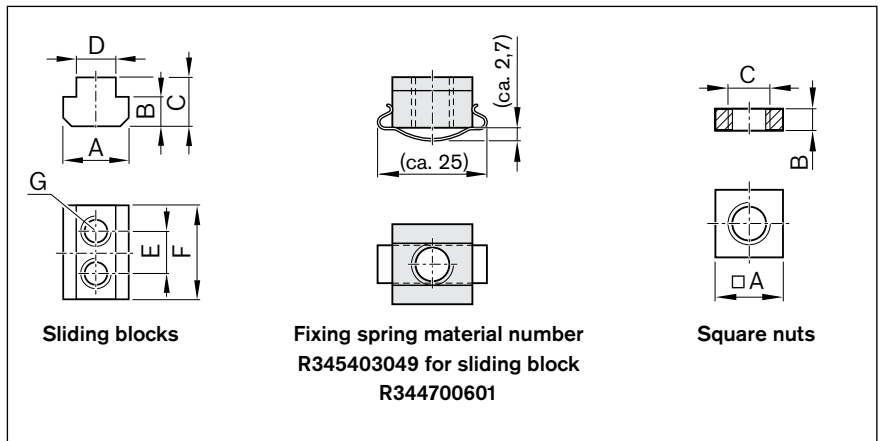

Threaded anchor strips

Steel, black finished

All anchor strips can be fixed in place for vertical installation.

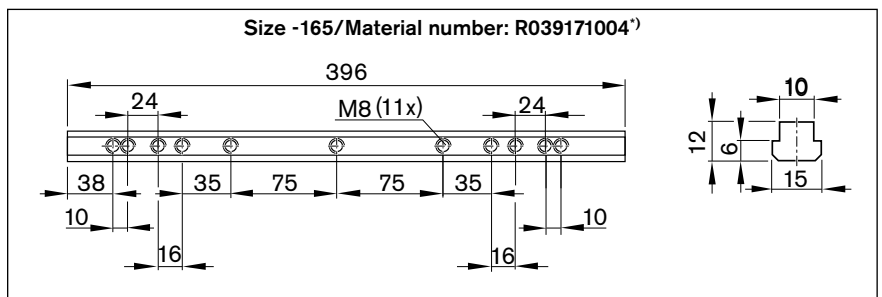
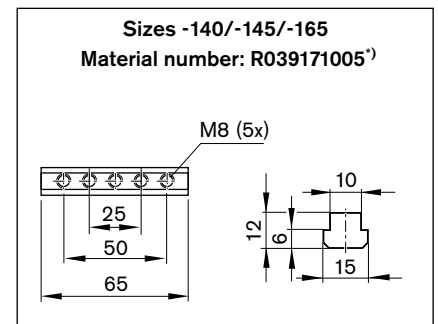
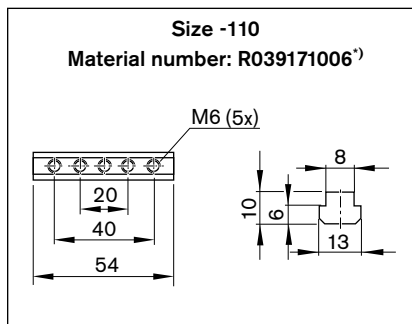
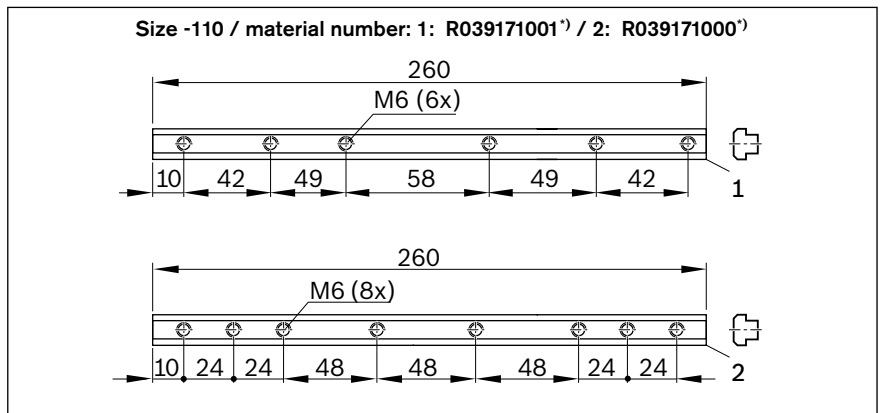
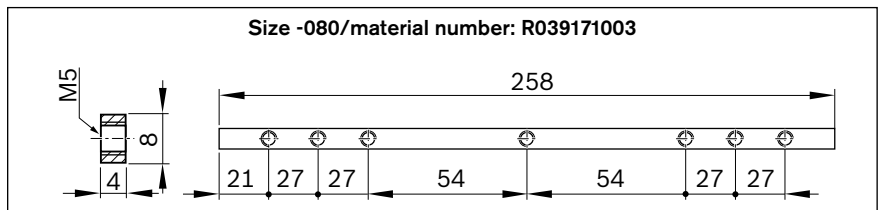

^{*)} Profile as per DIN 50

Attachments and accessories

Connecting shafts

Steel connecting shafts with disk-pack coupling

(shaft 1, 2)

- Compensation of misalignments
- Backlash-free and torsionally stiff
- Bridge large distances between axes
- Dynamically balanced as per VDI 2060

Connecting shafts with flexible membrane coupling

(shaft 3 - 6)

- Compensation of misalignments
- Backlash-free and torsionally stiff
- Bridge large distances between axes
- Clamping hub (mounting and removal without shifting aligned axes)
- Dynamically balanced as per VDI 2060

Order

Please state the material number and length L_{cs} when ordering. Subject to alternative version with unchanged technical data.

Notes on horizontal mounting orientation (version for vertical mounting orientation on request)

Alternative design subject to same technical data.



Install guards to protect against contact with rotating parts during operation!

Comply with the equipment safety rules and machinery safety regulations at all times!

Calculation of length L_{cs} for $i = 1$:

Shaft	Size	Length L_{cs} (mm)
1	-165	$L_M - 220$ mm
	-140	$L_M - 195$ mm
2	-110 / -145	$L_M - 140$ mm
	-080	$L_M - 120$ mm
3	-110 / -145	$L_M - 155$ mm
4	-080	$L_M - 144$ mm
5	-065	$L_M - 105$ mm
6	-040	$L_M - 55$ mm

L_{cs} = Overall length of the connecting shaft (mm)

L_M = Centerline-to-centerline distance of the linear module (mm)

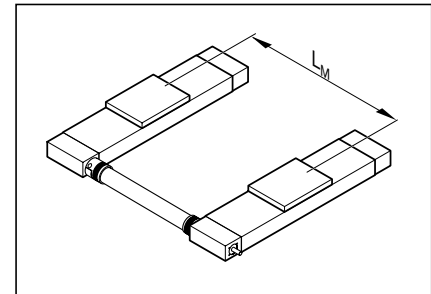

Critical speed as a function of overall length

n = Rpm (min⁻¹)
 L_{cs} = Overall length of the Connecting shaft (mm)

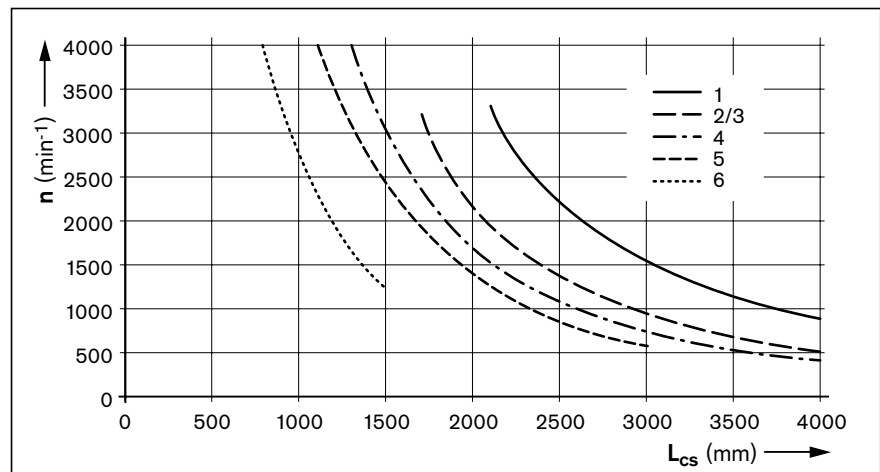

Dimensional drawings

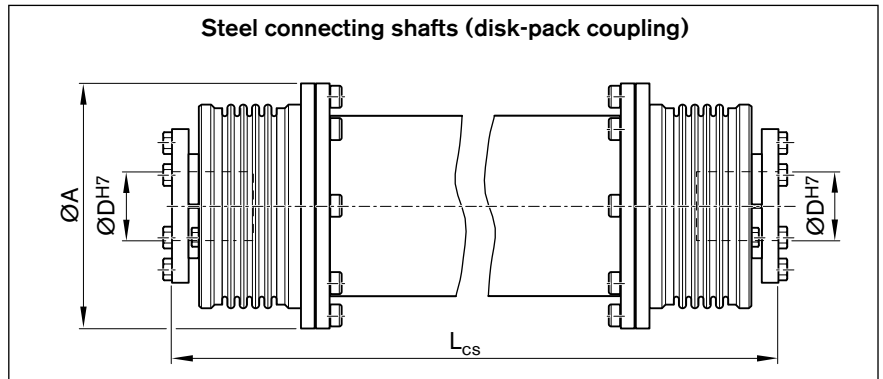

Material numbers and dimensions

Shaft	Size	Material number	Dimensions				Torque (Nm)	Weight (kg)	Flexibility		Mass moment of inertia (10^{-6} kgm ²)
			A (mm)	D (mm)	L _{CS} min (mm)	L _{CS} max (mm)			Δk_a (mm)	Δk_w (°)	
1	-140/-165	R039151011	149	35	280	4 000	400	$12.8 + 0.0115 \cdot (L_{CS} - 180)$	2.6	1	$32\,320 + 38.5 \cdot (L_{CS} - 180)$
2	-080/-110/-145	R039151012	110	18	250	4 000	100	$4.2 + 0.008 \cdot (L_{CS} - 160)$	1.8	1	$6,480 + 8.5 \cdot (L_{CS} - 160)$

Δk_a = axial flexibility (mm)

Δk_w = angled flexibility (°)

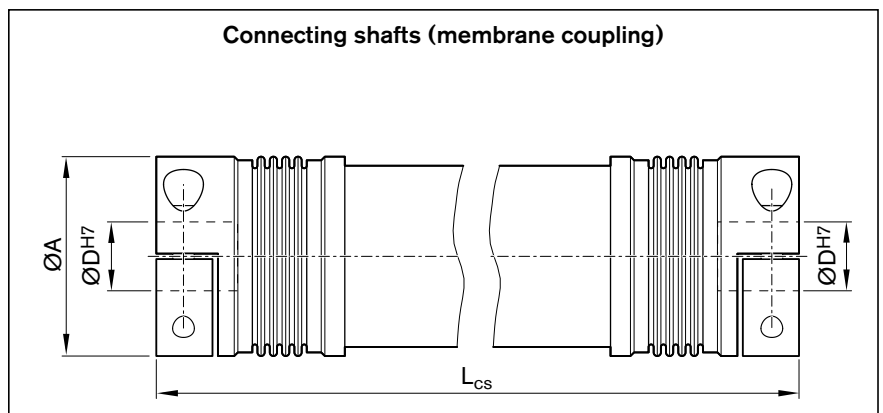

Material numbers and dimensions

Shaft	Size	Material number	Dimensions				Torque (Nm)	Weight (kg)	Mass moment of inertia (10^{-6} kgm ²)
			A (mm)	D (mm)	L _{CS} min (mm)	L _{CS} max (mm)			
3	-110/-145	R039151013	81	18	200	4 000	150.0	$2.00 + 0.00318 \cdot (L_{CS} - 160)$	$2,000 + 4.5 \cdot (L_{CS} - 160)$
4	-080	R039151014	66	18	171	4 000	60.0	$0.85 + 0.00145 \cdot (L_{CS} - 120)$	$510 + 1.18 \cdot (L_{CS} - 120)$
5	-065	R039151015	55	16	148	3 000	25.0	$0.62 + 0.0012 \cdot (L_{CS} - 120)$	$245 + 0.663 \cdot (L_{CS} - 120)$
6	-040	R039151021	32	10	101	1 500	12.5	$0.12 + 0.00054 \cdot (L_{CS} - 80)$	$30 + 0.09 \cdot (L_{CS} - 80)$

Attachments and accessories

Nozzle pipe

For manual grease guns. For the lubrication of funnel-type and ball-type lube nipples.

Scope of delivery:

Nozzle pipe, interchangeable insert A for funnel-type lube nipple, interchangeable insert B for ball-type lube nipple.

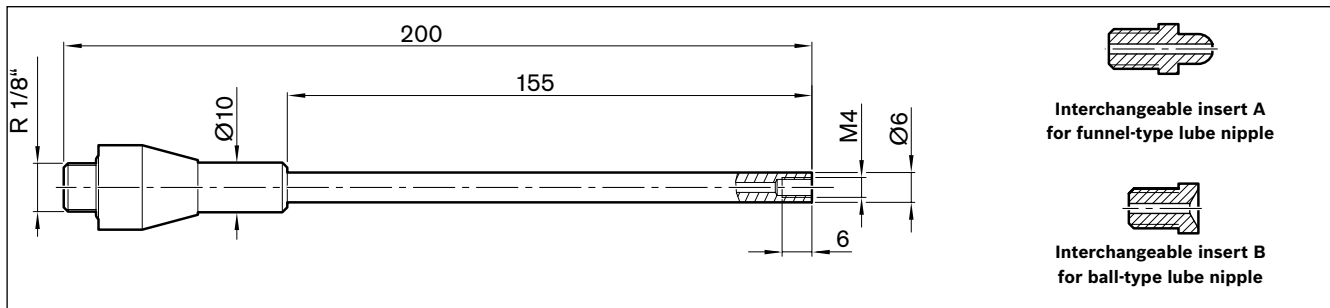

Material number	Mass (g)
R345503106	158

Frequency meter

for checking the toothed belt pretension on linear axes with a toothed belt drive, as well as the setting of the toothed belt pretension with a drive over the belt side drive.

Scope of delivery:

Frequency meter TECO-S MINI, plug-in scanner, extension cable, leather belt pouch.



Material number
R913057897

Connection technology for linear motion systems

Product description

In the past, machine manufacturers themselves have had to devise, design and manufacture systems for installing or mounting linear modules and for connecting linear modules with ball screw drives or belt drives.

The Robotic Erector System for linear modules facilitates these tasks and therefore leads to savings for the user, since the system comprises mass-produced, standardized components.

The result: users can respond flexibly to the varied requirements and uses of linear motion technology.

The system provides various possibilities for constructing two or three axes from linear modules and connection elements.

The basic elements (plates and brackets) have been designed to allow linear modules to be connected to other ones of the same size or one size larger or smaller.

The range also includes purpose-designed mounting accessories.

The linear modules and the connecting elements combine to form the Robotic Erector System for linear modules.

See the catalog for further information about the connection system "Connection system for linear systems".



Connection options

2 axes



Connection elements:
2 connection plates

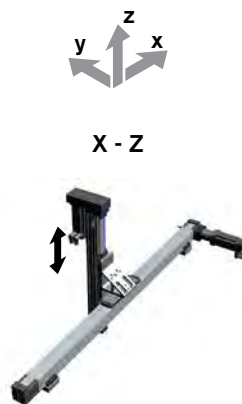

Linear module traverses in the Z-axis.

Connection elements:
1 connection bracket



Carriage traverses in the Z-axis

Connection elements:
2 connection plates

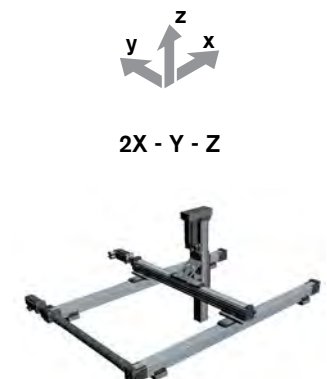

Connection elements:
2 connection plates
1 connection bracket

Motors

Motor attachment kits according to customer specification

The motor attachment for linear motion systems with ball screw assembly consists of either a mounting kit with flange and coupling (MF) or a timing belt side drive (SD).

The available combinations are shown in the "Configuration and ordering" selection tables for each size.

In addition to attachment kits for Rexroth motors, attachment kits for motors according to customer specification are also available. In order to determine the appropriate attachment kit, the connection geometry of the motor is crucial. Characteristics required to clearly determine motor geometry are shown below.

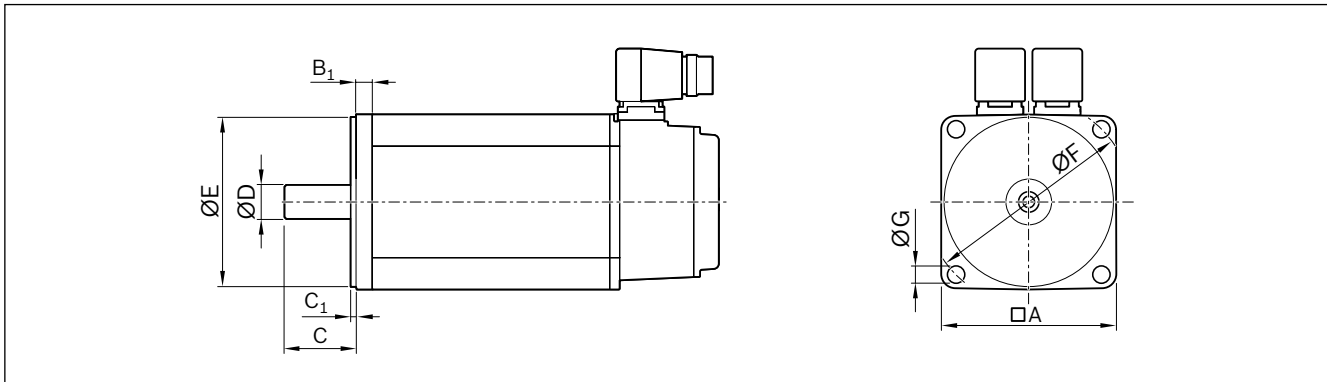

The dimensions queried result in a unique "motor geometry code":

□ □ - □ □ - □ □ □ - □ □ □ - □ □ □ - **M** □ □ - □ □ □ - □ □ □

- ØD = Shaft diameter
- C = Shaft length
- ØE = Centering diameter
- C_1 = Centering depth
- ØF = Pitch diameter
- ØG = Drill hole for mounting screw (specify thread diameter)
- B_1 = Flange thickness
- A = Flange edge dimension

Example illustration of servo motor IndraDyn S Type MS2N04

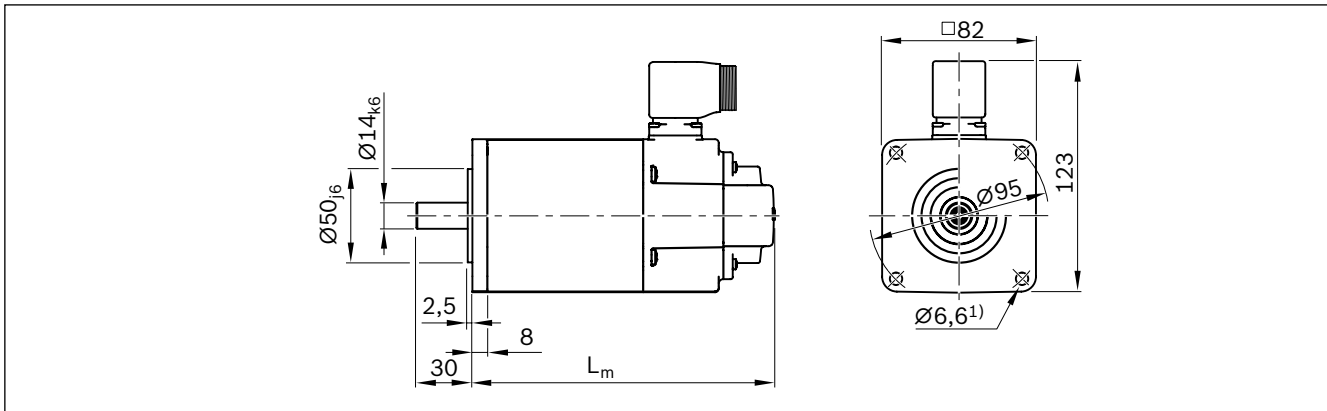

1 4 - 3 0 - 0 5 0 - 2 . 5 - 0 9 5 - M 0 6 - 0 0 8 - 0 8 2

¹⁾ The drill hole $\text{Ø} 6.6$ mm results in the type designation M06 for the geometry motor code (nominal thread diameter mounting screw M6).

Motor attachment kits for motors according to customer specification can be selected using the online configurator in the eShop. To do this, select the "mechanical interface" and "motors according to customer specification" option.

Dimensions customer motor

Motor manufacturer ▼

Motor type ▼

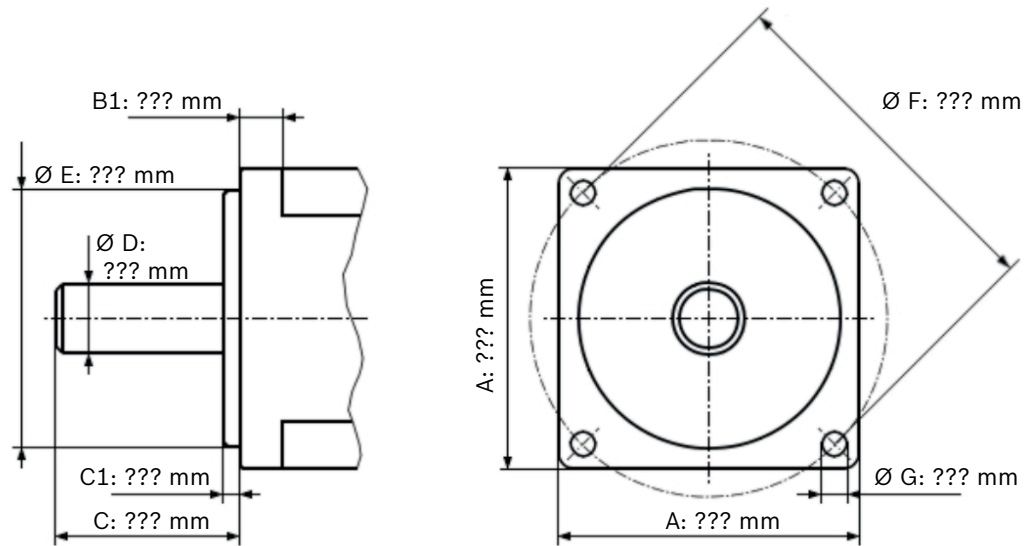

Example

Dimensions customer motor

Motor manufacturer ▼

Motor type ▼

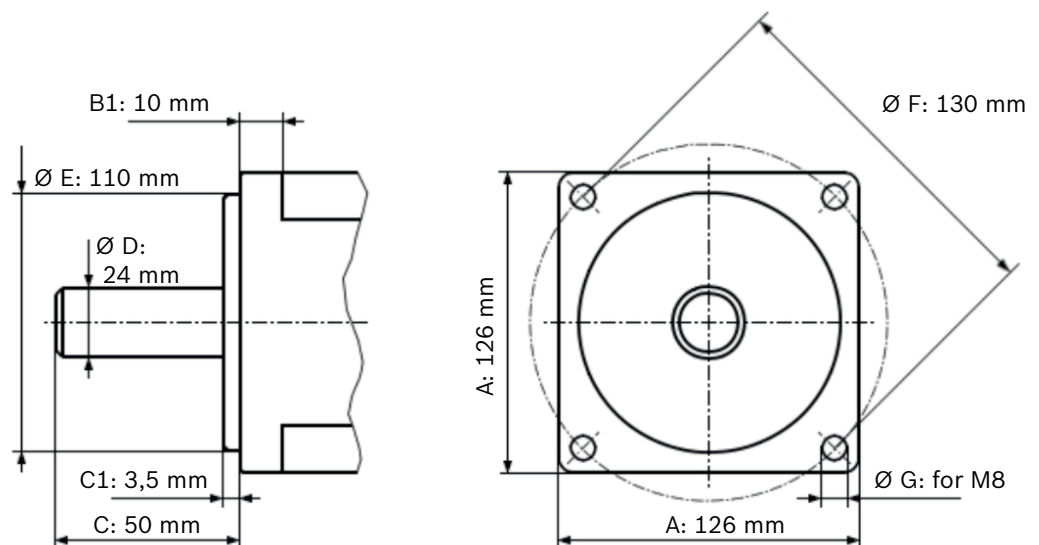

Motors

IndraDyn S - MSM servo motors

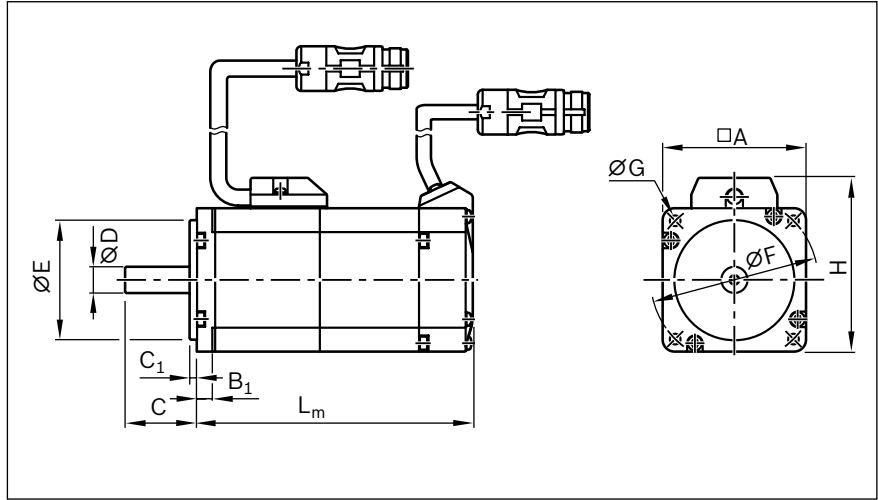

Motor schematic

Motor code	Dimensions (mm)										
	□ A	B ₁	C	C ₁	∅ D	∅ E	∅ F	∅ G	H	L _m	
										Brake without	with
MSM 019B-0300	38	6.0	25	3	8	30	45	3.4	51	92.0	122.0
MSM 031B-0300	60	6.5	30	3	11	50	70	4.5	73	79.0	115.5
MSM 031C-0300	60	6.5	30	3	14	50	70	4.5	73	98.5	135.0
MSM 041B-0300	80	8.0	35	3	19	70	90	6.0	93	112.0	149.0

Version:

- ▶ Plain shaft without shaft seal
- ▶ M5 multi-turn absolute encoder (20-bit, absolute encoder function only available with backup battery)
- ▶ Cooling system: natural convection
- ▶ IP54 rating (shaft: IP40)
- ▶ With or without holding brake
- ▶ M17 metal round connector

Note

Motors are available with control units and controllers. For more information on motors, controllers and control systems, please refer to the following Rexroth catalogs:

- ▶ Drive system Rexroth IndraDrive R999000018
- ▶ Automation Systems and Control Components, R999000026

Motor data									Motor connection	Brake	Type code	Material number
n_{max} (min ⁻¹)	M_0 (Nm)	M_{max} (Nm)	M_{br} (Nm)	J_m (kgm ²)	J_{br} (kgm ²)	m_m (kg)	m_{br} (kg)					
5 000	0.32	0.95	0.29	0.0000051	0.0000002	0.47	0.21	2	N	MSM 019B-0300-NN-M5-MH0	R911344211	
									Y	MSM 019B-0300-NN-M5-MH1	R911344212	
5 000	0.64	1.91	1.27	0.0000140	0.0000018	0.82	0.48	2	N	MSM 031B-0300-NN-M5-MH0	R911344213	
									Y	MSM 031B-0300-NN-M5-MH1	R911344214	
5 000	1.30	3.80	1.27	0.0000260	0.0000018	1.20	0.50	2	N	MSM 031C-0300-NN-M5-MH0	R911344215	
									Y	MSM 031C-0300-NN-M5-MH1	R911344216	
4 500	2.40	7.10	2.45	0.0000870	0.0000075	2.30	0.80	2	N	MSM 041B-0300-NN-M5-MH0	R911344217	
									Y	MSM 041B-0300-NN-M5-MH1	R911344218	

Motor characteristic
(Schematic)

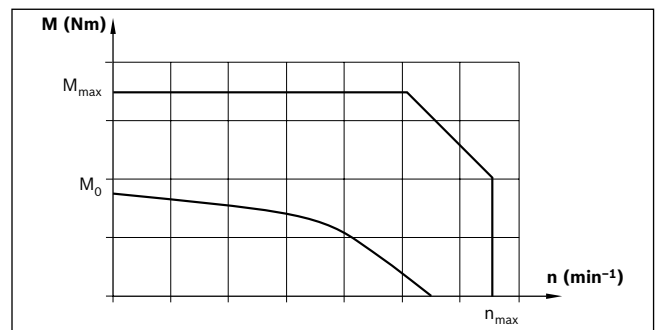

Motors

IndraDyn S - MS2N servo motors

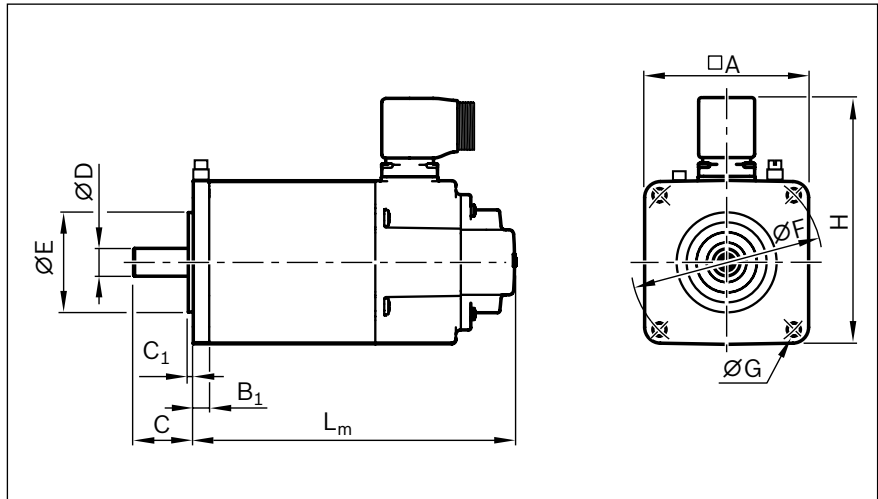

Motor schematic

Dimensions / Motor data

Motor code	Dimensions (mm)												
	□ A	B ₁	C	C ₁	∅ D _{k6}	∅ E ₁₇	∅ F	∅ G	Cable		H	L _m	
									2	1	Brake without	with	
MS2N03-B0BYN	58	7.5	20	2.5	9	40	63	4.5	84	99	163	192	
MS2N03-D0BYN	58	7.5	23	2.5	11	40	63	4.5	84	99	203	232	
MS2N04-B0BTN	82	8	30	2.5	14	50	95	6.6	108	123	162	194.5	
MS2N04-C0BTN	82	8	30	2.5	14	50	95	6.6	108	123	194	226.5	
MS2N04-D0BQN	82	8	30	2.5	14	50	95	6.6	108	123	226	258.5	
MS2N05-B0BTN	98	9	40	3	19	95	115	9	124	139	188	218	
MS2N05-C0BTN	98	9	40	3	19	95	115	9	124	139	224	254	
MS2N05-D0BRN	98	9	40	3	19	95	115	9	124	139	260	290	

Version

- ▶ Plain shaft without shaft seal ring
- ▶ Multi-turn encoder
- ▶ Standard encoder (B) in conjunction with 2-cable connector (HIPERFACE interface)
- ▶ Advanced encoder (B) in conjunction with 1-cable connector (AcuroLink interface)
- ▶ IP64 rating
- ▶ With or without holding brake
- ▶ Special ground connection terminal near motor flange (used as needed)

Notes:

Motors are available with control units and controllers. You can find more information on motors and control systems in the Rexroth catalogs on drive technology at www.boschrexroth.com/mediadirectory.

Motor data									Motor connection	Brake	Type code	Material number
n_{max} (min ⁻¹)	M_0 (Nm)	M_{max} (Nm)	M_{br} (Nm)	J_m (kgm ²)	J_{br} (kgm ²)	m_m (kg)	m_{br} (kg)					
9 000	0.73	3.46	1.8	0.000023	0.000007	1.4	0.4	2	N	MS2N03-B0BYN-BMDH0-NNNNE-NN	R911384765	
								2	Y	MS2N03-B0BYN-BMDH1-NNNNE-NN	R911384766	
								1	N	MS2N03-B0BYN-CMSH0-NNNNE-NN	R911384767	
								1	Y	MS2N03-B0BYN-CMSH1-NNNNE-NN	R911384769	
9 000	1.15	6.8	1.8	0.000037	0.000007	2.0	0.4	2	N	MS2N03-D0BYN-BMDH0-NNNNE-NN	R911384770	
								2	Y	MS2N03-D0BYN-BMDH1-NNNNE-NN	R911384771	
								1	N	MS2N03-D0BYN-CMSH0-NNNNE-NN	R911384772	
								1	Y	MS2N03-D0BYN-CMSH1-NNNNE-NN	R911384773	
6 000	1.75	5.9	5.0	0.000070	0.000040	2.7	0.7	2	N	MS2N04-B0BTN-BMDH0-NNNNE-NN	R911384525	
								2	Y	MS2N04-B0BTN-BMDH1-NNNNE-NN	R911384526	
								1	N	MS2N04-B0BTN-CMSH0-NNNNE-NN	R911384527	
								1	Y	MS2N04-B0BTN-CMSH1-NNNNE-NN	R911384528	
6 000	2.80	12.0	5.0	0.000110	0.000050	3.7	0.7	2	N	MS2N04-C0BTN-BMDH0-NNNNE-NN	R911384529	
								2	Y	MS2N04-C0BTN-BMDH1-NNNNE-NN	R911384530	
								1	N	MS2N04-C0BTN-CMSH0-NNNNE-NN	R911384531	
								1	Y	MS2N04-C0BTN-CMSH1-NNNNE-NN	R911384532	
6 000	3.85	18.1	5.0	0.000160	0.000040	4.7	0.7	2	N	MS2N04-D0BQN-BMDH0-NNNNE-NN	R911384533	
								2	Y	MS2N04-D0BQN-BMDH1-NNNNE-NN	R911384534	
								1	N	MS2N04-D0BQN-CMSH0-NNNNE-NN	R911384535	
								1	Y	MS2N04-D0BQN-CMSH1-NNNNE-NN	R911384536	
6 000	3.75	10.6	10.0	0.000170	0.000110	4.0	1.1	2	N	MS2N05-B0BTN-BMDH0-NNNNE-NN	R911384539	
								2	Y	MS2N05-B0BTN-BMDH1-NNNNE-NN	R911384540	
								1	N	MS2N05-B0BTN-CMSH0-NNNNE-NN	R911384542	
								1	Y	MS2N05-B0BTN-CMSH1-NNNNE-NN	R911384543	
6 000	6.10	20.8	10.0	0.000290	0.000110	5.9	1.1	2	N	MS2N05-C0BTN-BMDH0-NNNNE-NN	R911384544	
								2	Y	MS2N05-C0BTN-BMDH1-NNNNE-NN	R911384545	
								1	N	MS2N05-C0BTN-CMSH0-NNNNE-NN	R911384546	
								1	Y	MS2N05-C0BTN-CMSH1-NNNNE-NN	R911384547	
6 000	7.90	31.3	10.0	0.000400	0.000110	7.3	1.1	2	N	MS2N05-D0BRN-BMDH0-NNNNE-NN	R911384548	
								2	Y	MS2N05-D0BRN-BMDH1-NNNNE-NN	R911384549	
								1	N	MS2N05-D0BRN-CMSH0-NNNNE-NN	R911384550	
								1	Y	MS2N05-D0BRN-CMSH1-NNNNE-NN	R911384551	

Motors

IndraDyn S - MS2N servo motors

Dimensions / Motor data

Motor code	Dimensions (mm)												L _m
	□ A	B ₁	C	C ₁	∅ D	∅ E	∅ F	∅ G	H		Brake		
									Cable 2	1	without	with	
MS2N06-B1BNN	116	14	50	3	24	95	130	9	156	156	164	201	
MS2N06-C0BTN	116	14	50	3	24	95	130	9	156	156	184	202	
MS2N06-D0BRN	116	14	50	3	24	95	130	9	156	156	224	261	
MS2N06-D1BNN	116	14	50	3	24	95	130	9	156	156	224	261	
MS2N07-B1BNN	140	18	58	4	32	130	165	11	180	180	176	230	
MS2N07-C0BQN	140	18	58	4	32	130	165	11	180	180	205	259	
MS2N07-C1BRN	140	18	58	4	32	130	165	11	180	180	205	259	
MS2N07-D0BRN	140	18	58	4	32	130	165	11	180	180	263	317	
MS2N07-D1BNN	140	18	58	4	32	130	165	11	180	180	263	317	
MS2N07-E0BQN	140	18	58	4	32	130	165	11	180	180	321	375	

	Motor data								Motor connection	Brake	Type code	Material number
	n_{\max} (min^{-1})	M_0 (Nm)	M_{\max} (Nm)	M_{br} (Nm)	J_m (kgm^2)	J_{br} (kgm^2)	m_m (kg)	m_{br} (kg)				
6 000	3.25	9.5	10.0	0.000480	0.000110	5.1	1.1	2	N	MS2N06-B1BNN-BMUH0-NNNNE-NN	R911384927	
								2	Y	MS2N06-B1BNN-BMUH1-NNNNE-NN	R911384928	
								1	N	MS2N06-B1BNN-CMSH0-NNNNE-NN	R911384929	
								1	Y	MS2N06-B1BNN-CMSH1-NNNNE-NN	R911384930	
6 000	6.00	16.0	10.0	0.000390	0.000110	6.4	1.0	2	N	MS2N06-C0BTN-BMUH0-NNNNE-NN	R911384931	
								2	Y	MS2N06-C0BTN-BMUH1-NNNNE-NN	R911384932	
								1	N	MS2N06-C0BTN-CMSH0-NNNNE-NN	R911384933	
								1	Y	MS2N06-C0BTN-CMSH1-NNNNE-NN	R911384934	
6 000	9.70	32.0	15.0	0.000650	0.000140	9.0	1.5	2	N	MS2N06-D0BRN-BMUH0-NNNNE-NN	R911384935	
								2	Y	MS2N06-D0BRN-BMUH2-NNNNE-NN	R911384936	
								1	N	MS2N06-D0BRN-CMSH0-NNNNE-NN	R911384937	
								1	Y	MS2N06-D0BRN-CMSH2-NNNNE-NN	R911384938	
6 000	9.00	38.4	15.0	0.001400	0.000140	9.0	1.5	2	N	MS2N06-D1BNN-BMUH0-NNNNE-NN	R911384939	
								2	Y	MS2N06-D1BNN-BMUH2-NNNNE-NN	R911384940	
								1	N	MS2N06-D1BNN-CMSH0-NNNNE-NN	R911384941	
								1	Y	MS2N06-D1BNN-CMSH2-NNNNE-NN	R911384942	
6 000	7.40	21.0	20.0	0.001970	0.000260	9.5	2.0	2	N	MS2N07-B1BNN-BMUH0-NNNNE-NN	R911384949	
								2	Y	MS2N07-B1BNN-BMUH1-NNNNE-NN	R911384950	
								1	N	MS2N07-B1BNN-CMSH0-NNNNE-NN	R911384951	
								1	Y	MS2N07-B1BNN-CMSH1-NNNNE-NN	R911384952	
6 000	12.8	35.7	20.0	0.001200	0.000260	12.0	2.0	2	N	MS2N07-C0BQN-BMUH0-NNNNE-NN	R911384953	
								2	Y	MS2N07-C0BQN-BMUH1-NNNNE-NN	R911384954	
								1	N	MS2N07-C0BQN-CMSH0-NNNNE-NN	R911384955	
								1	Y	MS2N07-C0BQN-CMSH1-NNNNE-NN	R911384956	
6 000	11.50	42.2	20.0	0.003050	0.000260	12.0	2.0	2	N	MS2N07-C1BRN-BMUH0-NNNNE-NN	R911384957	
								2	Y	MS2N07-C1BRN-BMUH1-NNNNE-NN	R911384958	
								1	N	MS2N07-C1BRN-CMSH0-NNNNE-NN	R911384959	
								1	Y	MS2N07-C1BRN-CMSH1-NNNNE-NN	R911384960	
6 000	22.0	73.2	36.0	0.00210	0.000410	17.5	2.5	2	N	MS2N07-D0BRN-BMVH0-NNNNE-NN	R911384961	
								2	Y	MS2N07-D0BRN-BMVH2-NNNNE-NN	R911384962	
6 000	18.90	84.8	36.0	0.005290	0.000410	17.5	2.5	2	N	MS2N07-D1BNN-BMUH0-NNNNE-NN	R911384963	
								2	Y	MS2N07-D1BNN-BMUH2-NNNNE-NN	R911384964	
								1	N	MS2N07-D1BNN-CMSH0-NNNNE-NN	R911384965	
								1	Y	MS2N07-D1BNN-CMSH2-NNNNE-NN	R911384966	
6 000	29.2	109.5	36.0	0.00300	0.0000410	23.0	3.0	2	N	MS2N07-E0BQN-BMVH0-NNNNE-NN	R911384967	
								2	Y	MS2N07-E0BQN-BMVH2-NNNNE-NN	R911384968	

Switching system MKK, MKR, MLR

Overview of switching system

1. Socket and plug
2. Mechanical switch with attachments
3. Proximity sensor
4. Switching angle
5. Mounting channel / cable channel
6. Magnetic field sensor with fixed potted cable
(Reed/Hall sensor (for mounting channel))
7. Assembly magnetic sensor with plug and sensor mount
 - 7a: Magnetic sensor
 - 7b: Sensor mount incl. set screws (loose) and square nut
 - 7c: Cable holder (3 pcs) incl. set screw (loose)
 - 7d: Male connector M8x1, 3-pin
8. Magnetic sensor with M8x1 plug
9. Clamping screw
10. Sliding block

Switch mounting arrangement MKK/MKR-040-NN-3

Magnetic sensor with M8x1 plug, switch mounting plate and cable holder

The switch activator is a magnet (on both sides) that is built into the carriage (no switching cam necessary). The switch activation points can be positioned anywhere along the stroke. For position solenoid switch, see the linear module instructions R320103169.

Instruction for mounting:

The magnetic sensor is inserted into the corresponding slot of the sensor mount and fixed by turning the clamping screw in the sensor mount.

Sensors may only be mounted on one side (left or right) of the linear module and should not be installed until the linear module has been screwed down on its base. For a description of the mounting procedure and determination of the switch activation points, see the mounting instructions for linear modules.

See the section titled "Attachments and accessories" for technical data.

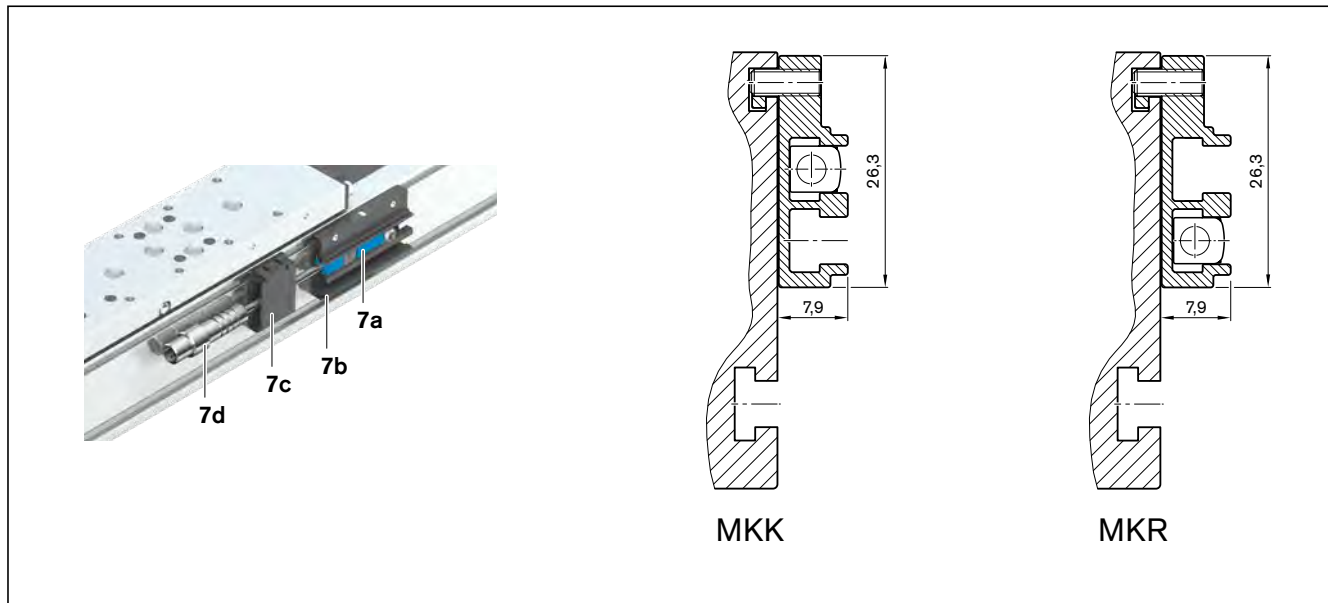

Position	Switching function	Material number	Option number	Position	Material number
7	PNP NC	R117500140	(130)	7a	R913037445
7	NPN/NC	R117500141	(131)	7a	R913037443
7	PNP NO	R117500142	(132)	7a	R913037444
7	NPN/NO	R117500143	(133)	7a	R913037446
				7b	R037530021
				7c	R037530022

Further switch mounting options (MKK/MKR-040-NN-3)

Magnetic field sensor (6) and mounting channel (5)

Instruction for mounting:

A mounting channel is needed to fasten the magnetic field sensors and cable guides.

This is suspended at the side in the upper slot at the linear module MKK / MKR-040 and secured with set screws.

The magnetic field sensors are pushed into the top (MKK) or bottom T-slot (MKR) in the mounting channel and fixed with set screws.

The switch activator is a magnet (on both sides) that is built into the carriage (no switching cam necessary). The switch activation points can be positioned anywhere along the stroke. For position solenoid switch, see the linear module instructions R320103169.

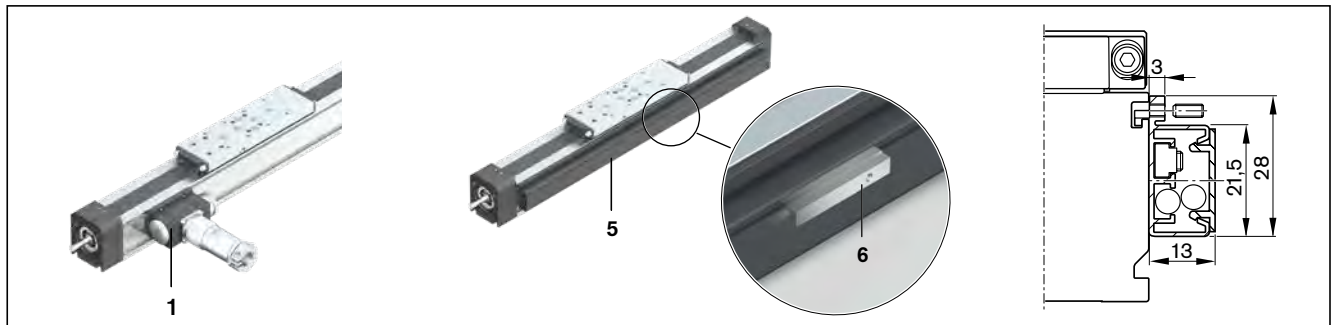

Position	Name	Material number	Name	Material number
1	Socket - plug	R117560102		
5	Mounting channel	R039662018		
6	Reed sensor (cable length 2 m)	R347600903	Reed sensor (cable length 10 m)	R913011323
6	Hall sensor (cable length 2 m)	R347601003	Hall sensor (cable length 10 m)	R913011324

Proximity sensors and mechanical switches

Instruction for mounting:

The mechanical switches, the proximity sensors and the box with connector and cable channel are fastened with attachments in T-slots of the frame. Switch activation is carried out by a switch bracket on the carriage.

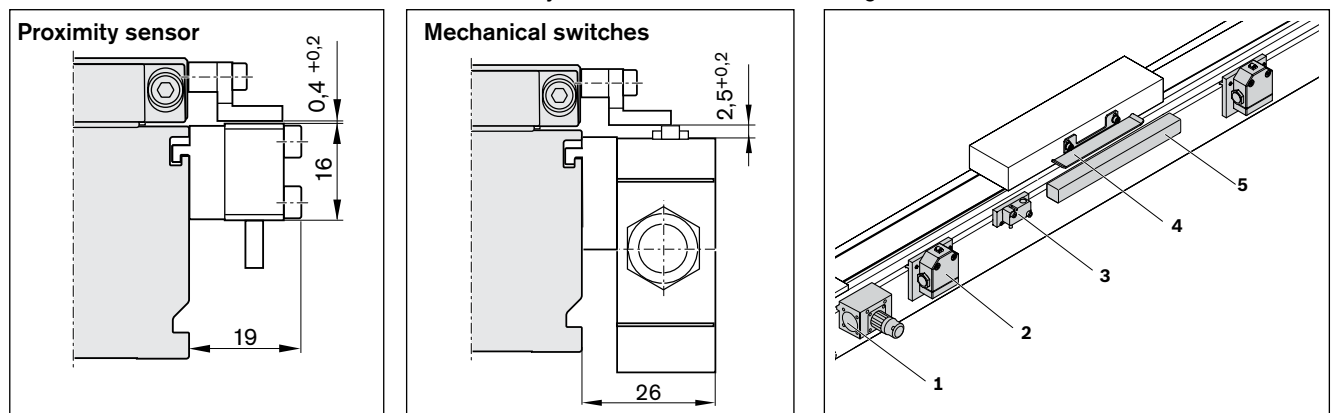

Further dimensions, see chapter "Inductive sensors, mechanical switches and accessories" on the following pages

Position	Name	Material number
1	Socket - plug	R117560102
2	Mechanical switch	See the chapter on sensors and accessories
	Mechanical switch with attachments	R039980087
3	Proximity sensor	See the chapter on sensors and accessories
	Attachment parts without sensor	R117560103
	Proximity sensor with attachments	R039980088 (PNP - NC) R039980095 (PNP - NO)
4	Switching angle	R039980104
5	Mounting channel	R039662018

These switching versions can only be ordered with these material numbers

Switch mounting MKK/MKR -065/-080/-110/-140-NN-3

Magnetic sensor with M8x1 plug

The switch activator is a magnet (on both sides) that is built into the carriage (no switching cam necessary). The switch activation points can be positioned anywhere along the stroke. For position solenoid switch, see the linear module instructions R320103169.

Instruction for mounting:

The magnetic sensor is positioned in the corresponding sensor slot (S) and fixed by turning the clamping screw. The sliding block (10) is not necessarily required for mounting, it is only required for repeatable mounting of the sensor.

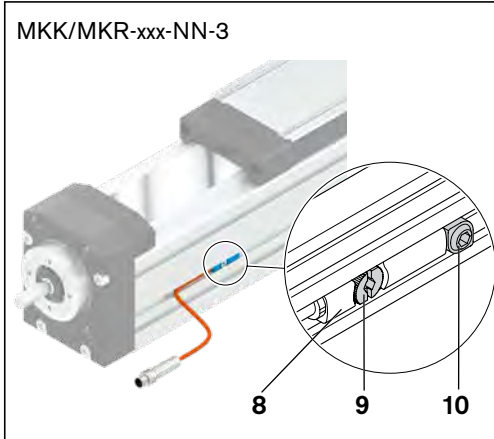

Position	Switching function	Material number	Option number
8	PNP NC	R913037445	(120)
8	NPN/NC	R913037443	(121)
8	PNP NO	R913037444	(122)
8	NPN/NO	R913037446	(123)
10	Sliding block	R117509008	---

Further sensors/switches, see chapter "Inductive sensors, mechanical switches and accessories" on the following pages

Switch mounting arrangement MLR-080/-110-NN-3

Magnetic sensor with M8x1 plug

The switch activator is a magnet (on both sides) that is built into the carriage (no switching cam necessary). The switch activation points can be positioned anywhere along the stroke. For position solenoid switch, see the linear module instructions R320103169.

Instruction for mounting:

Insert sensor mount (a) into the sensor slot (S), position approximately and fix with two set screws (b). Then, install the magnetic sensor (8) in the sensor mount and fix by turning the clamping screw (9).

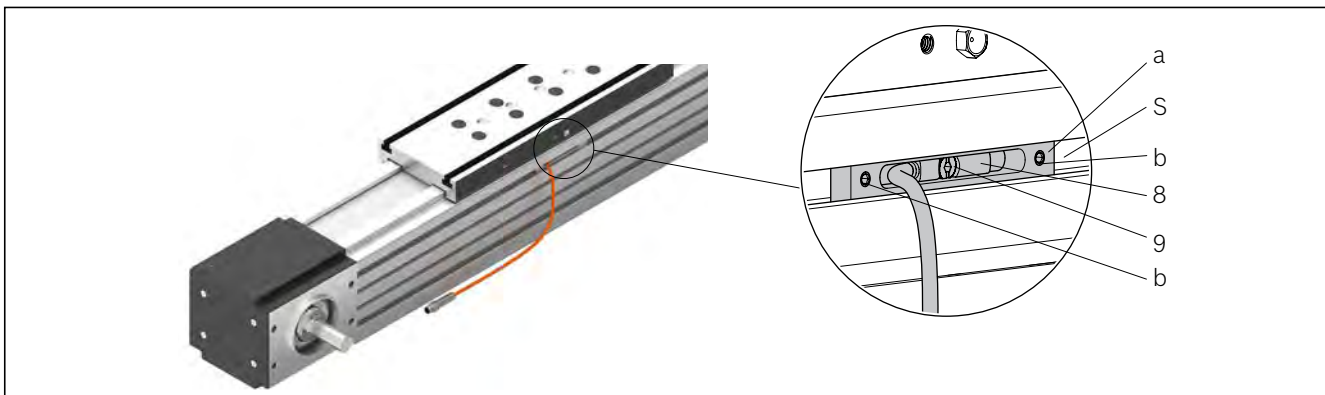

Position	Switching function	MLR-080-NN-3		MLR-110-NN-3	
		Material number	Option number	Material number	Option number
		Assembly with sensor		Assembly with sensor	
8 + a	PNP NC	R039980210	(140)	R039980214	(144)
8 + a	NPN/NC	R039980211	(141)	R039980215	(145)
8 + a	PNP NO	R039980212	(142)	R039980216	(146)
8 + a	NPN/NO	R039980213	(143)	R039980217	(147)

Assembly magnetic sensor with plug includes magnetic sensor, sensor mount including set screws (loose).

Further sensors/switches, see chapter "Inductive sensors, mechanical switches and accessories" on the following pages

Switch mounting arrangement MKR-145-NN-3

Magnetic sensor with M8x1 plug

The switch activator is a magnet (on both sides) that is built into the carriage (no switching cam necessary). The switch activation points can be positioned anywhere along the stroke. For position solenoid switch, see the linear module instructions R320103169.

Instruction for mounting:

Insert sensor mount (a) into the sensor slot (S), position approximately and fix with two set screws (b). Then, install the magnetic sensor (8) in the sensor mount and fix by turning the clamping screw (9).

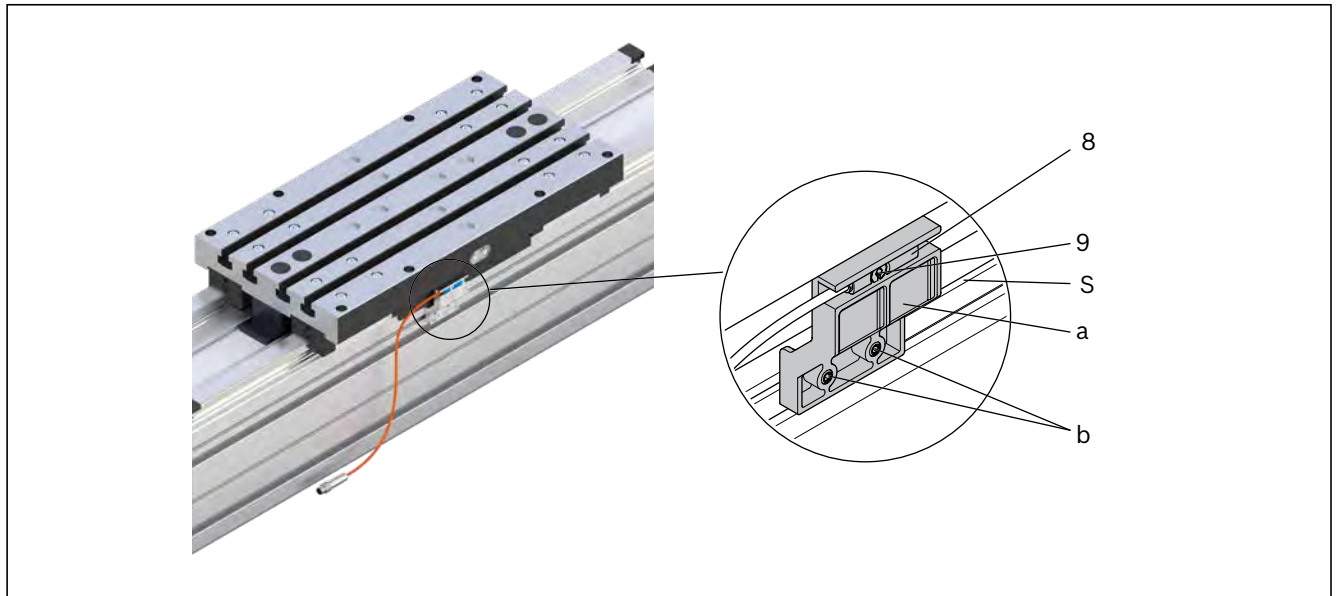

Item	Switching function	Material number	Option number
		Assembly with sensor	
8 + a	PNP NC	R039980140	(125)
8 + a	NPN/NC	R039980142	(126)
8 + a	PNP NO	R039980141	(127)
8 + a	NPN/NO	R039980143	(128)

Assembly magnetic sensor with plug includes magnetic sensor, sensor mount including set screws (loose).

Further sensors/switches, see chapter "Inductive sensors, mechanical switches and accessories" on the following pages

Inductive sensors, mechanical switches and accessories (MKK/MKR/MLR)

Instruction for mounting:

The mechanical switches, the proximity sensors and the box with connector and cable channel are fastened with attachments in T-slots of the frame. Switch activation is carried out by a switch bracket on the carriage.

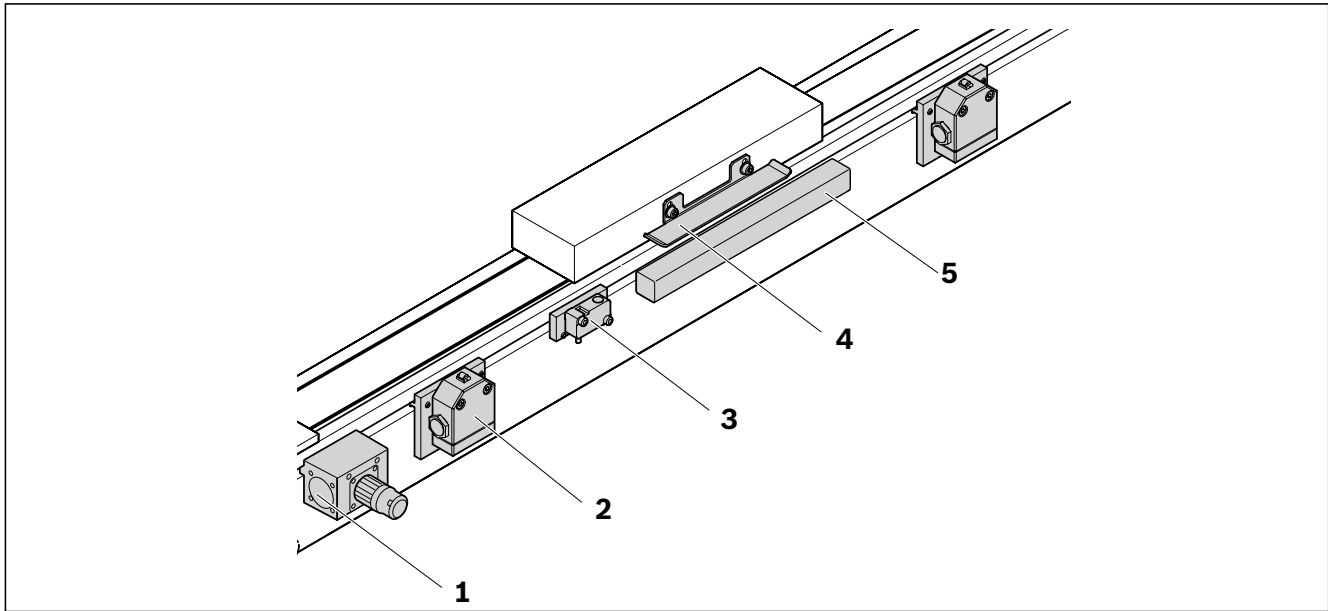

Pos.	Name	Material number		
		Sizes -065 / -080 / -140 /-145-NN-3	-110-NN-3	-165-NN-2
1	Socket-plug	R117500153		
2	Mechanical switch	See the chapter on sensors and accessories		
	Mech. Switch with attachments	R117500151		
	Attachment parts without mech. Switches	R117500165		
3	Proximity sensor	See the chapter on sensors and accessories		
	Attachment parts without sensor	R117500152	R117520152	R117500152
	Proximity sensor with attachments	R039980001 (PNP - NC)	R039980010 (PNP - NC)	R039980001 (PNP - NC)
		R039980002 (NPN - NC)	R039980011 (NPN - NC)	R039980002 (NPN - NC)
		R039980003 (PNP - NO)	R039980012 (PNP - NO)	R039980003 (PNP - NO)
R039980004 (NPN - NO)		R039980013 (NPN - NO)	R039980004 (NPN - NO)	
4	Switching angle	R117500149	R117500150	
5	Cable channel	R039662017		

These switching versions can only be ordered with these material numbers

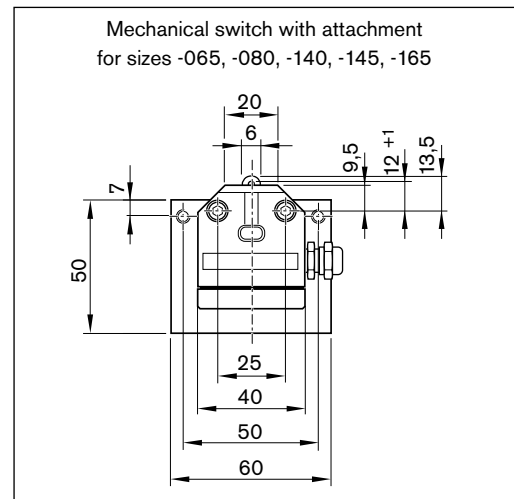
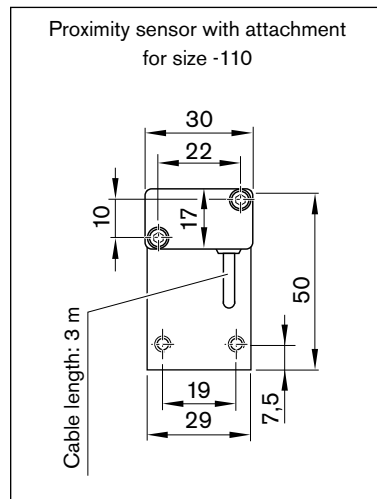
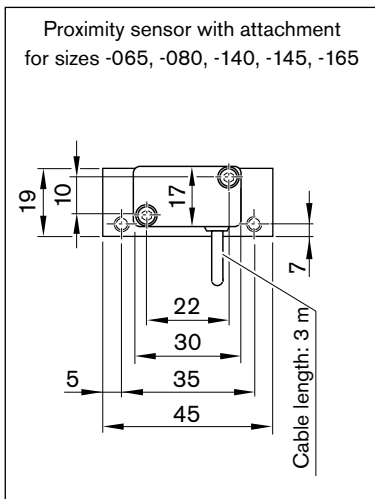

Cable channel

The cable duct is fastened in the T-slots on the side of the frame. Fastening screws widen the profile and ensure that the cable channel is securely mounted. The cable channel will accommodate up to two cables for mechanical switches and three cables for proximity switches. Fastening screws and cable grommets are included.

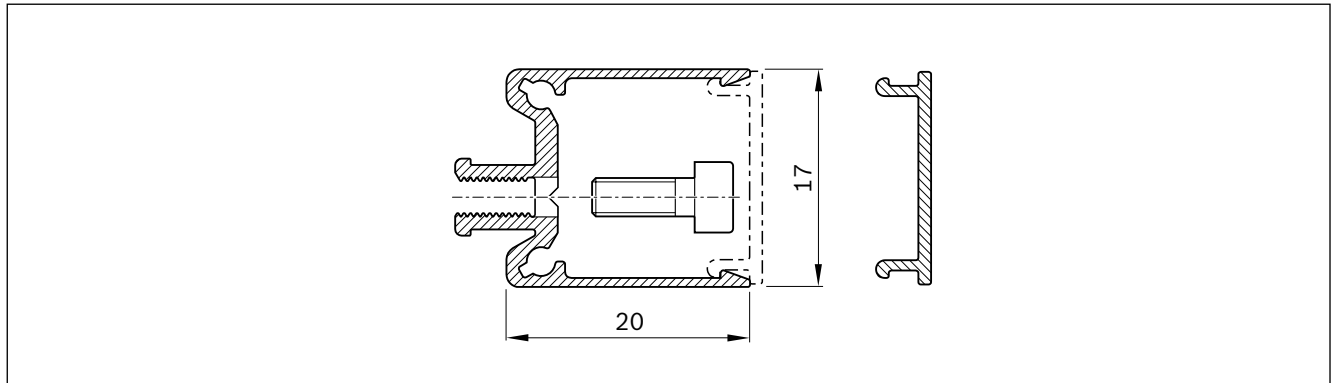

Mounting examples of switches

Determining the switch activation points

Switching distance: The switching distance is the distance between the carriage center (CC) and the zero point (0) when a switch is activated (given in mm). Example for a mechanical limit switch (provided the zero point is at $L/2$):

Maximum switching distance = $0.5 \times (\text{max. travel distance}) - \text{excess travel} = 0.5 \times \text{effective stroke}$

For safe operation of the linear module, the excess travel must be longer than the braking distance.

For MKR... and MLR...: The acceleration travel s_a can be taken as a guideline value for the braking distance.

For MKK...: In most cases the recommended limit for excess travel (braking path) is: $\text{Excess travel} = 2 \times \text{screw lead } P$.

Take note of the minimum switching distance (determined by the attachments):

mechanical-mechanical = 60 mm; mechanical-proximity = 45 mm; proximity-proximity = 28 mm.

For MKR-145: mechanical-mechanical = 62 mm; mechanical-proximity = 49 mm; proximity-proximity = 35 mm

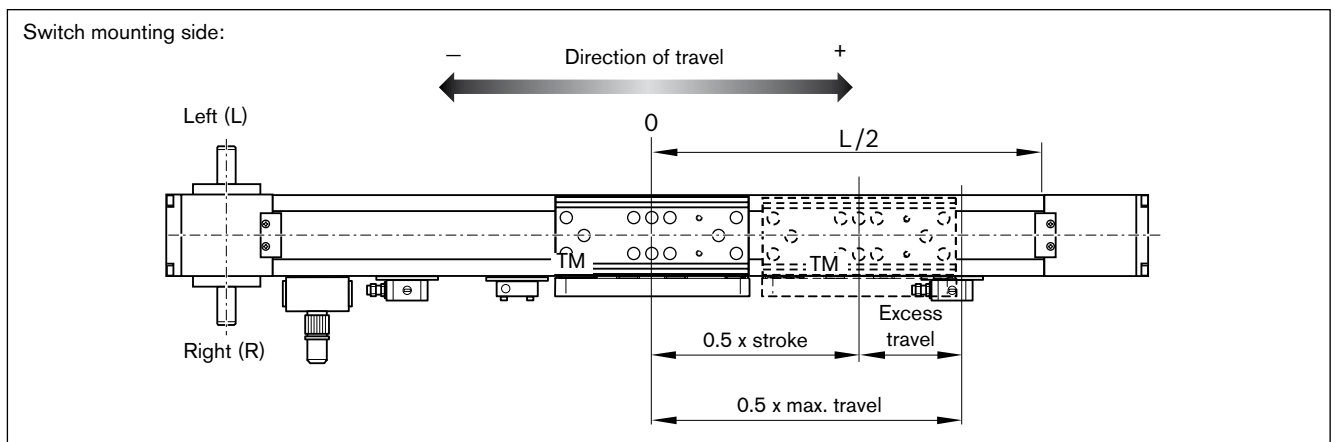

Switch mounting

MKK/MKR-065/-080/-110/-140-NN-3; MKK/MKR-165-NN-2

Magnetic sensor, mechanical switch / proximity sensors

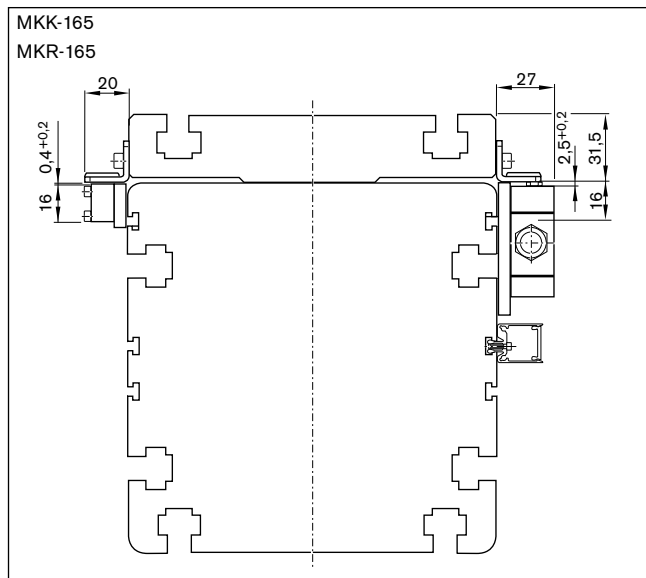
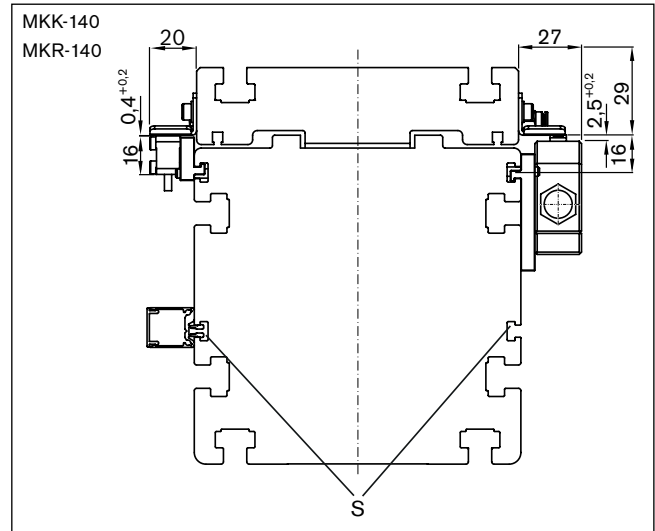
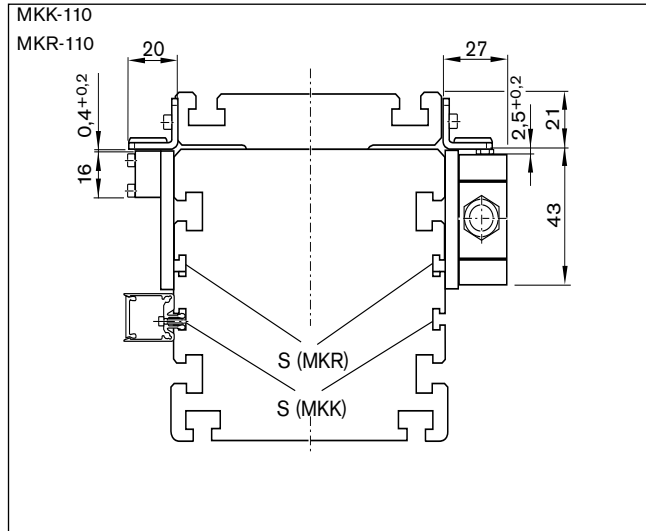
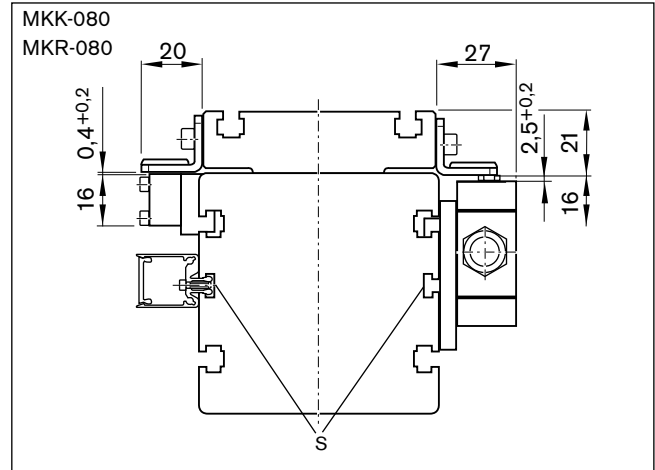
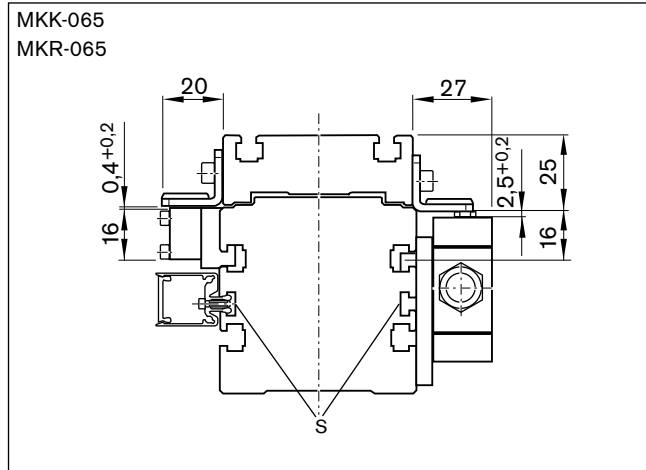

S = Sensor slot for magnetic sensor MKK/MKR-xxx-NN-3

Switch mounting

MLR-080 / -110-NN-3

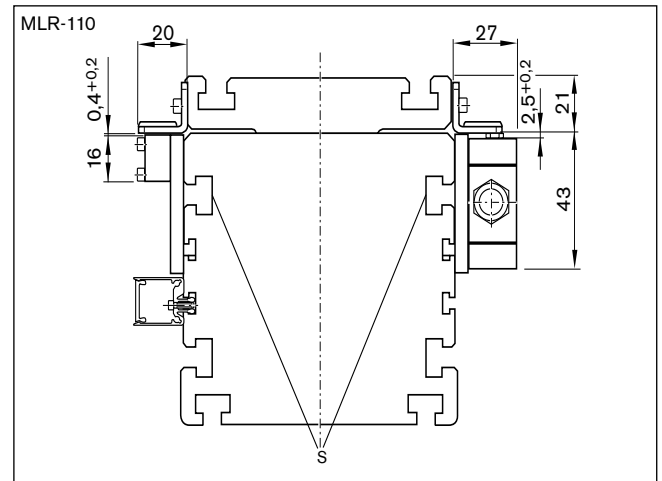
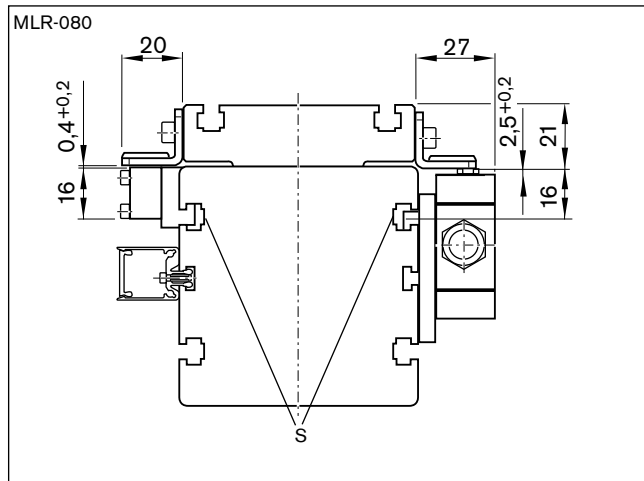

S = Slot for sensor mount MLR-xxx-NN-3

Switch mounting

MKR-145-NN-3

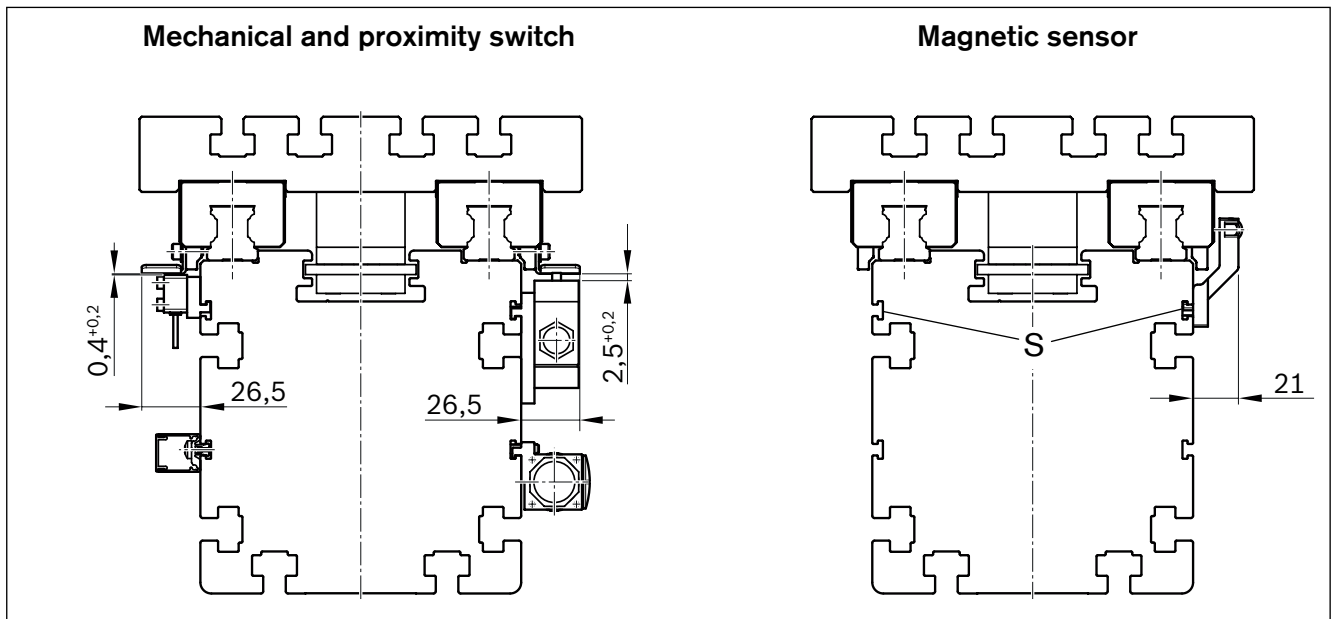

S = Slot for sensor mount MKR-145-NN-3

Switching system MKK, MKR, MLR

Socket and plug, cable channel

Attach the socket to the side with the most switches. The socket and plug are not pre-wired. The variable sliding attachment allows switching positions to be optimized during start-up. The plug can be mounted in three directions.

R117560102

Pin		Color
1	BN	brown
2	WH	white
3	BU	blue
4	BK	black
5	GY	gray

R037540000

16-pin plug

R117500153

16-pin plug

Use	Socket and plug		
Material number	R117560102	R037540000	R117500153
Name	for MKK / MKR -040	for MKK / MKR -040	for MKx -065/-080/-110/-145/-165 for MLR-080/-110
Version	angled, for suspension in the lateral slot of the linear motion system		
Operating current per contact	max. 4 A	max. 8 A	
Operating voltage	10–30 V DC	150V AC/DC	
Connector Type 1	Straight plug, M12x1, 5-pin, spring-cage connection	Straight plug, 16-pin, soldered connection	
2nd Connection type	Coupling / flange socket M12x1, 5-pin, with 0.5 m cable	Coupling / flange socket, 16-pin, soldered connection	
Housing cable bushing	Cable gland M16x1.5 with seal (hole 3x3.5 mm) incl. cap and blind plug	1 seal with hole 2x5.5 mm, 1x3.5 mm seal 1 adaptable seal, max. 14 mm diameter incl. cap and blind plug	
Cable bushing, plug	Gland with pull relief		
Connection cross-section	0.14 ... 0.5 mm	0.14 ... 1 mm	
Cable diameter	4 ... 8 mm	10 ... 14 mm	
Ambient temperature	-25°C to +85°C	-20°C to +125°C	
Protection type	-		
Certifications and licenses	-		

Sensors

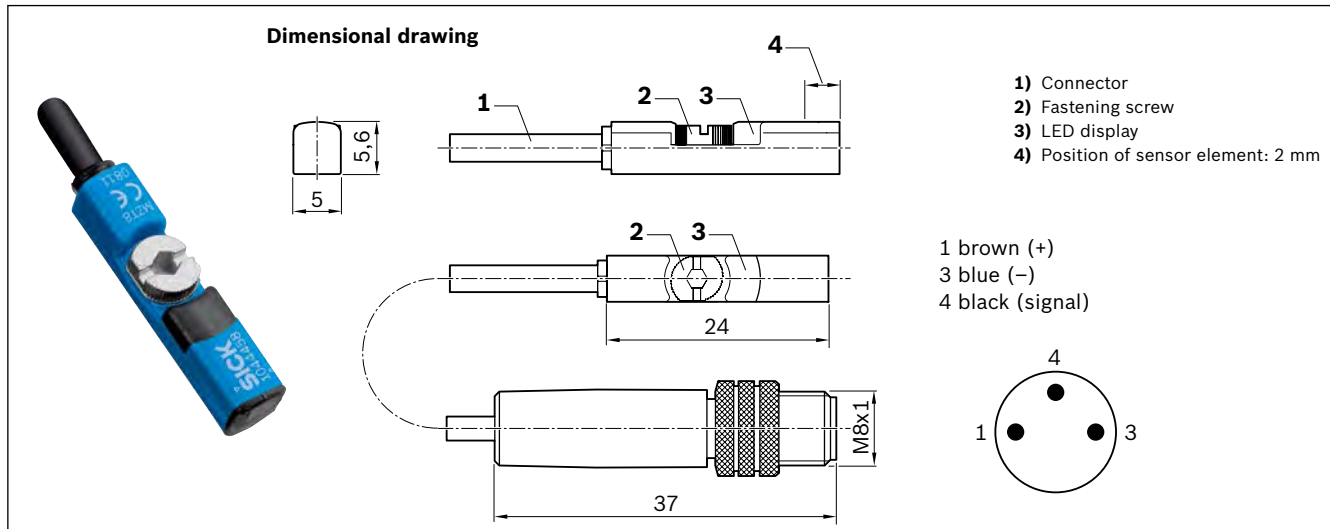

Magnetic sensor

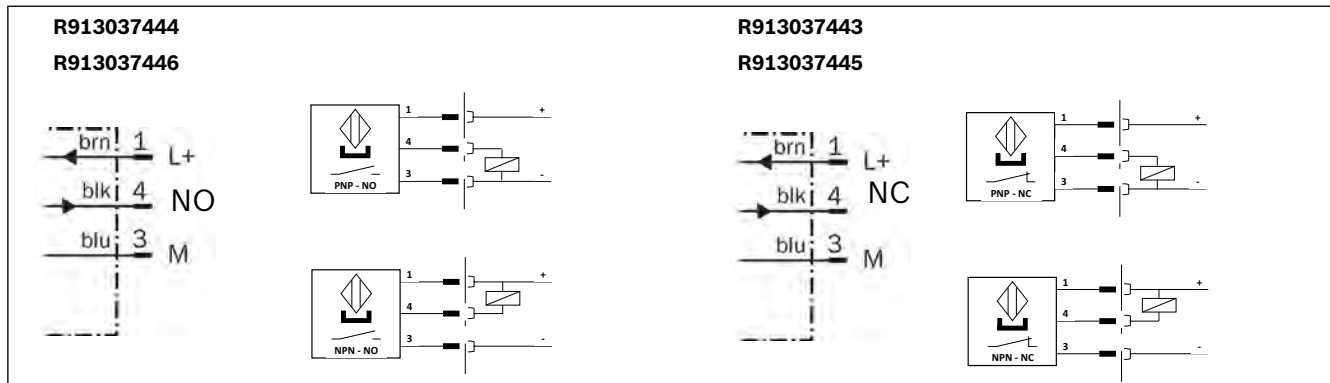

Connection diagram



Material numbers/technical data

Use	Limit switch	Reference switch	Limit switch	Reference switch
Material number	R913037445	R913037444	R913037443	R913037446
Name	MZT8-03VPO-KRDS14	MZT8-03VPS-KRDS13	MZT8-03VNO-KRDS16	MZT8-03VNS-KRDS15
Functional principle	magnetic			
Operating voltage	10 - 30 VDC			
Load current	≤ 200 mA			
Switching function	PNP NC	PNP NO	NPN/NC	NPN/NO
Connection type	0.5 m cable and M8x1 connector, 3-pin with knurled screw connection			
Function indicator	✓			
Short-circuit protection	✓			
Reverse polarity protection	✓			
Switch-on suppression	✓			
Switching frequency	3 kHz			
Pulse elongation (off delay)	20 ms			
Max. permissible starting speed	5 m/s			
Suitable for drag chains*	✓			
Torsion-resistant*	✓			
Welding spark-resistant*	-			
Cable cross-section*	3x0.14 mm ²			
Cable diameter D*	2.9 ±0.15 mm			
Static bending radius*	≥ 5xD			
Dynamic bending radius*	≥ 10xD			
Bending cycles*	> 2 mil.			
Max. permissible travel speed*	5 m/s			
Max. permissible acceleration*	≤ 5 m/s ²			
Ambient temperature	-30°C bis +80°C			
Protection type	IP68			
MTTFd (per EN ISO 13849-1)	MTTFd = 2339.0 years			
Certifications and Licenses**	  			

*) Technical data for connection line (0.5 m) cast on magnetic sensor only. Available extension cables offer even more performance, e.g. for use in a cable drag chain (see below).

**) No  certificate for import to the Chinese market required for these products. Document "CCC sales information" available on request.

Sensors

Magnetic sensor with free cable end

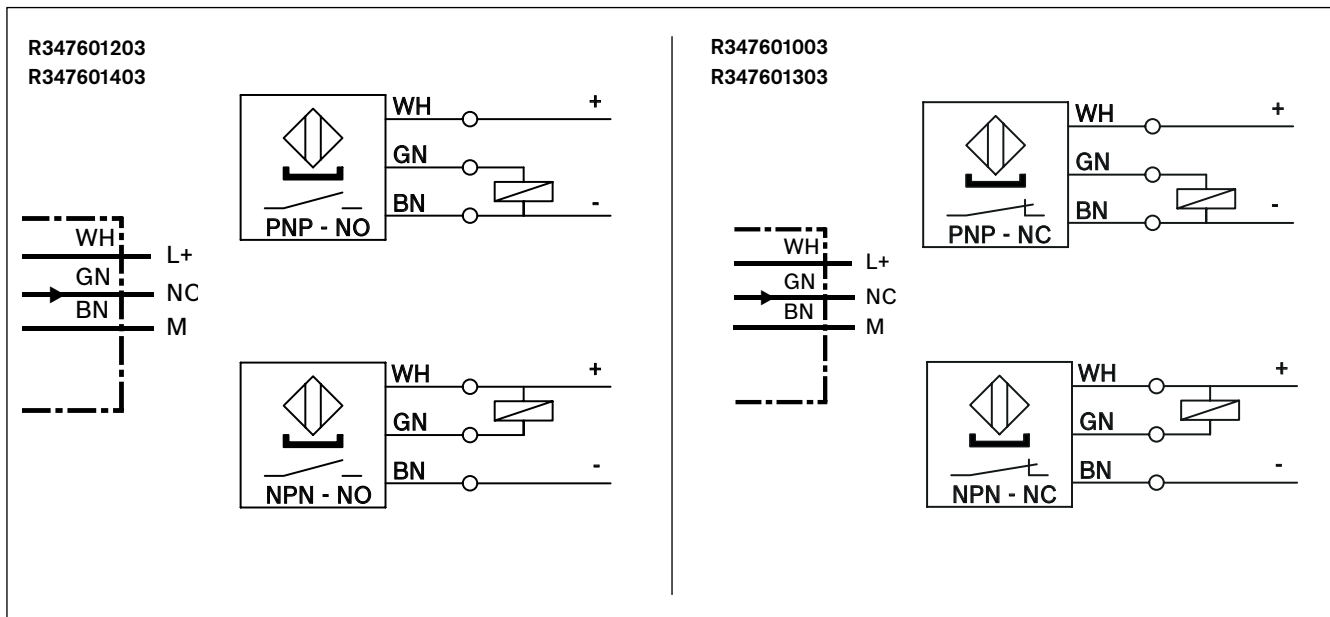
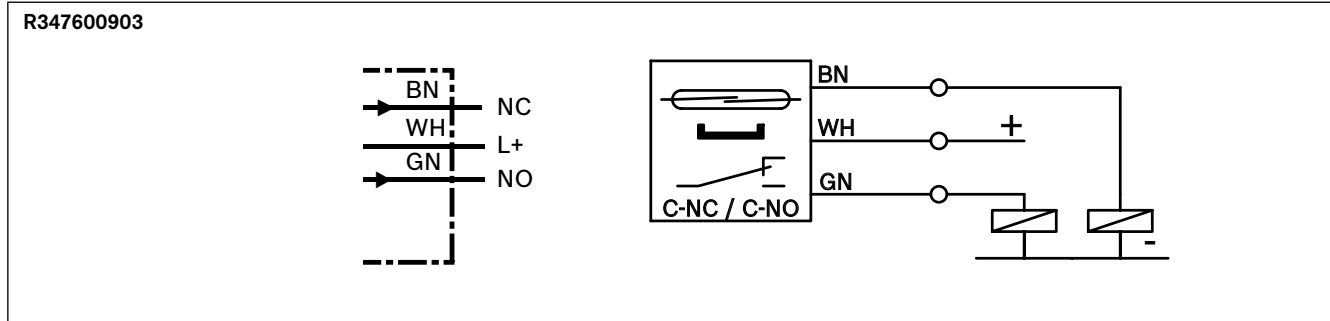
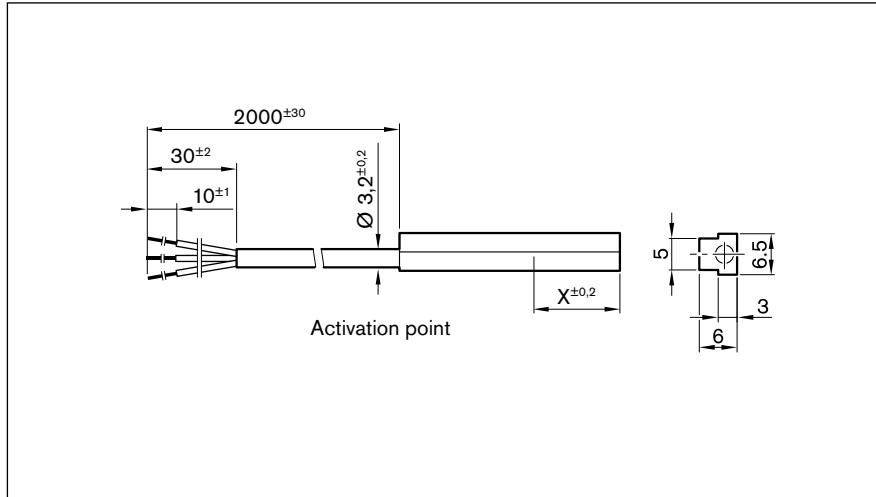
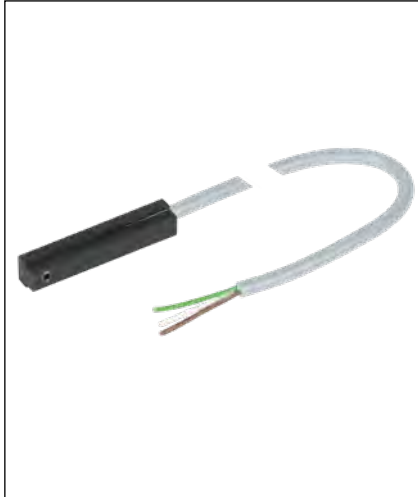

Material number R347600903

Use	Reference, limit switch
Material number	R347600903
Name	R12212
Functional principle	magnetic
Operating voltage	max. 30 V DC
Load current	500 mA
Switching function	REED/changeover contact: (NC: C+NC, NO: C+NO)
Activation point (dimension "X")	9 mm

Material numbers R347601003 / R347601203 / R347601403 / R347601303

Use	Limit switch	Reference switch	Limit switch	Reference switch
Material number	R347601003	R347601203	R347601303	R347601403
Name	H14118	H15637	H15638	H15080
Functional principle	magnetic			
Operating voltage	3.8 - 30 V DC			
Load current	≤ 20 mA			
Switching function	Hall PNP NC	Hall PNP NO	Hall NPN/NC	Hall NPN/NO
Activation point dimension "X"	13.65 mm			

Technical data for R347600903 / R347601003 / R347601203 / R347601403 / R347601303

Connection type	Cable 2.0 m, 3-pin
Galvanized connection ends	✓
Function indicator	–
Short-circuit protection	–
Reverse polarity protection	–
Switch-on suppression	–
Switching frequency	2.5 kHz
Pulse elongation (off delay)	–
Max. permissible starting speed	2 m/s
Suitable for drag chains*	–
Torsion-resistant*	–
Welding spark-resistant*	–
Cable cross-section*	3x0.14 mm ²
Cable diameter D	3.2 ±0.20 mm
Static bending radius*	–
Dynamic bending radius*	–
Bending cycles*	–
Max. permissible travel speed*	–
Max. permissible acceleration*	–
Ambient temperature	–40°C to +85°C
Protection type	IP66
MTTFd (per EN ISO 13849-1)	–
Certifications and Licenses**	–

* Technical data only for built-in sensor connection line.

Even more performance, e.g. extension cables are offered for use in a cable drag chain (refer to the following pages).

**) No  certificate is required to introduce these products to the Chinese market.

Sensors

Magnetic sensor with M8x1 plug

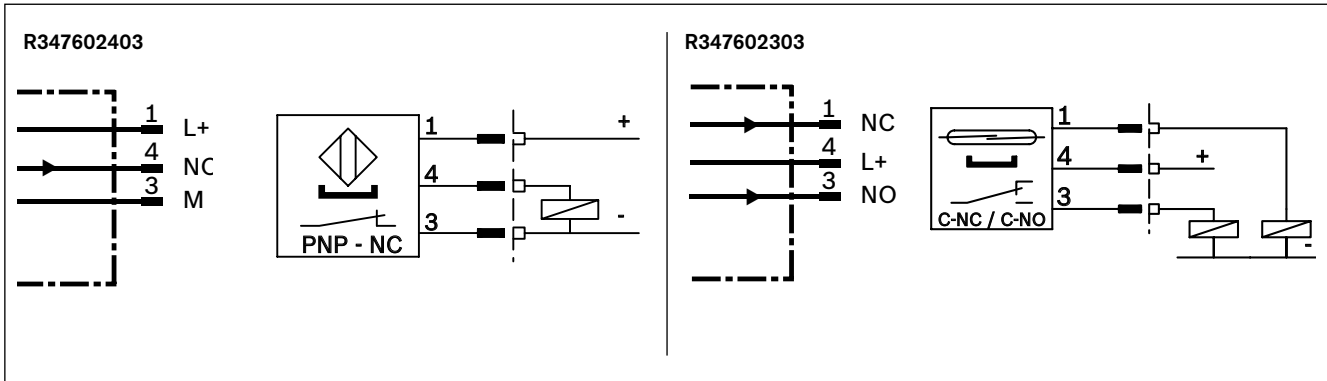
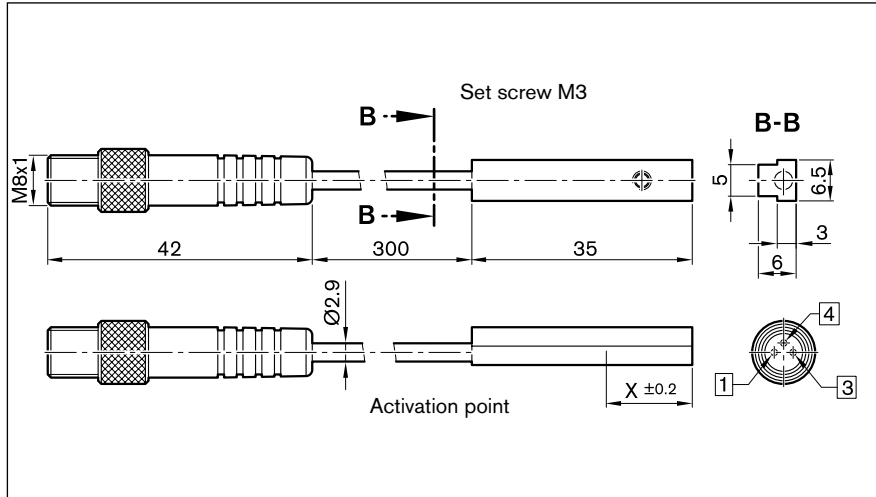





Material numbers/technical data

Use	Reference / limit switch	Limit switch
Material number	R347602403	R347602303
Name	H10706	R10705
Functional principle	magnetic	
Operating voltage	3.8 - 30 V DC	30 V DC
Load current	≤ 20 mA	500 mA
Switching function	Hall PNP NC	REED/single-pole changeover (NC: C+NC, NO: C+NO)
Activation point dimension "X"	13.65 mm	9 mm
Connection type	0.3 m cable and M8x1 connector, 3-pin with knurled screw connection	
Function indicator	-	
Short-circuit protection	-	
Reverse polarity protection	-	
Switch-on suppression	-	
Switching frequency	2.5 kHz	
Pulse elongation (off delay)	-	
Max. permissible starting speed	2 m/s	
Suitable for drag chains*	-	
Torsion-resistant*	-	
Welding spark-resistant*	-	
Cable cross-section*	3x0.14 mm ²	
Cable diameter D*	3.2 ±0.20 mm	
Static bending radius*	-	
Dynamic bending radius*	-	
Bending cycles*	-	
Max. permissible travel speed*	-	
Max. permissible acceleration*	-	
Ambient temperature	-40°C to +85°C	
Protection type	IP66	
MTTFd (per EN ISO 13849-1)	-	
Certifications and Licenses**	-	

*) Technical data for connection line (0.3 m) cast on magnetic sensor only.

The available extension cables offer even better performance, e.g., when using a cable drag chain (see following pages).

***) No  certificate is required to introduce these products to the Chinese market.

Material numbers/technical data				
Use	Limit switch	Reference switch	Limit switch	Reference switch
Material number	R345304001	R345304003	R345304002	R345304004
Name	BES 517-351-NO-C-03	BES 517-398-NO-C-03	BES 517-352-NO-C-03	BES 517-399-NO-C-03
Functional principle	inductive			
Operating voltage	10–30 V DC			
Load current	≤ 200 mA			
Switching function	PNP NC	PNP NO	NPN/NC	NPN/NO
Connection type	Line 3 m, 3-pin, free line end			
Function indicator	✓			
Short-circuit protection	✓			
Reverse polarity protection	✓			
Switching frequency	2.5 kHz			
Max. perm. starting speed	depending on the length of the switching cam			
Suitable for drag chains*	–			
Torsion-resistant*	–			
Welding spark-resistant*	–			
Cable cross-section*	3x0.14 mm ²			
Cable diameter D*	3.5 ±0.15 mm			
Static bending radius*	12 mm			
Dynamic bending radius*	12 mm			
Bending cycles*	–			
Ambient temperature	–40°C to +70°C			
Protection type	IP65			
MTTFd (acc. to EN ISO 13849-1)	MTTFd = 830 years		MTTFd = 585 years	
Certifications and Licenses**	  			

*) Technical data only for the cast-on connection line at the proximity sensor.

Even more performance, e.g. extension cables are offered for use in a cable drag chain (refer to the following pages).



***) No  certificate is required to introduce these products to the Chinese market.

Sensors

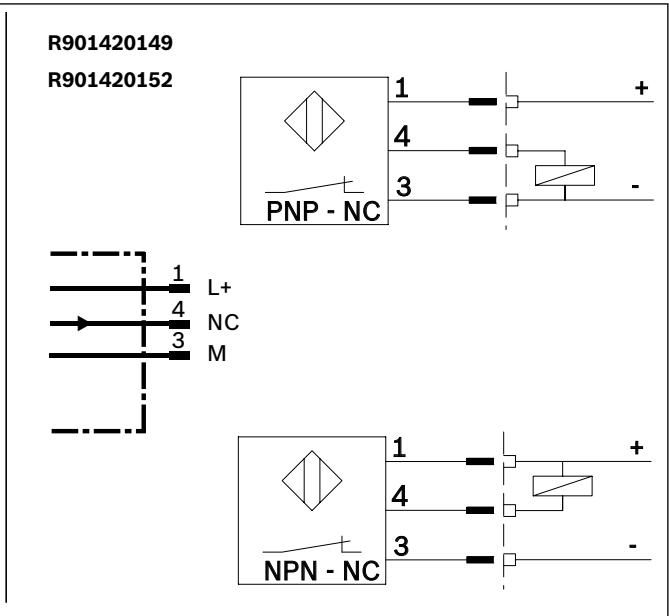
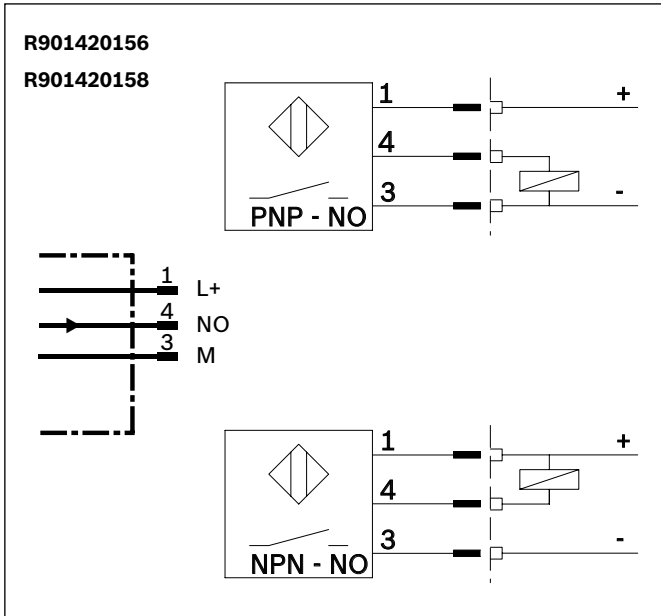
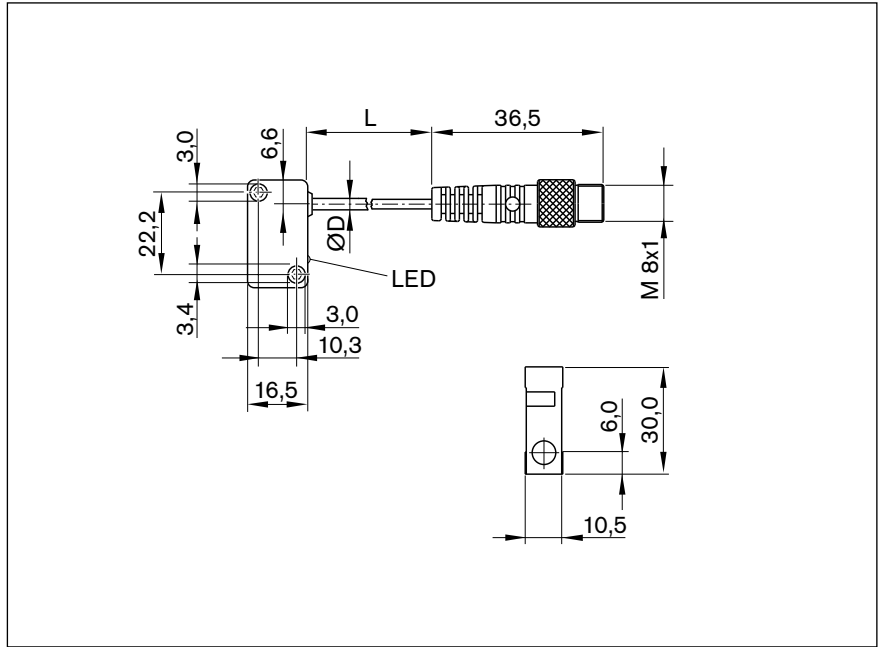
Proximity sensor with M8x1 plug



Material numbers/technical data



Use	Limit switch	Reference switch	Limit switch	Reference switch
Material number	R901420149	R901420156	R901420152	R901420158
Name	BES 517-351-NO-C-S49-00.2	BES 517-398-NO-C-S49-00.2	BES 517-352-NO-C-S49-00.2	BES 517-399-NO-C-S49-00.2
Functional principle	inductive			
Operating voltage	10–30 V DC			
Load current	≤ 200 mA			
Switching function	PNP NC	PNP NO	NPN/NC	NPN/NO
Connection type	Cable 0.2 m and plug M8 x 1, 3-pin with knurled screw			
Function indicator	✓			
Short-circuit protection	✓			
Reverse polarity protection	✓			
Switching frequency	2.5 kHz			
Max. permissible starting speed	depending on the length of the switching cam			
Suitable for drag chains*	–			
Torsion-resistant*	–			
Welding spark-resistant*	–			
Cable cross-section*	3x0.14 mm ²			
Cable diameter D*	3.5 ±0.15 mm			
Static bending radius*	12 mm			
Dynamic bending radius*	12 mm			
Bending cycles*	–			
Ambient temperature	–40°C to +70°C			
Protection type	IP65			
MTTFd (per EN ISO 13849-1)	MTTFd = 830 years		MTTFd = 585 years	
Certifications and Licenses**	  			

*) Technical data only for the cast-on connection line at the proximity sensor.

Even more performance, e.g. extension cables are offered for use in a cable drag chain (refer to the following pages).

***) No  certificate is required to introduce these products to the Chinese market.

Material numbers/technical data



Use	Limit switch	
Material number	R345304016	R347600305
Name	BNS 819-X496-99-R-11	BNS 819-X510-99-R-10
Functional principle	mechanical, roller	
Operating voltage	250 V AC	
Load current	≤ 5 A	
Switching function	single-pole changeover / (NC: C+NC, NO: C+NO)	
Connection type	Screw connection, without line	
Function indicator	-	
Switching frequency	3.3 Hz	
Max. permissible starting speed	1 m/s	
Ambient temperature	-5°C to +85°C	
Protection type	IP67	
B10d value	5x10 ⁶ (wet area); 10x10 ⁶ (dependent on current load (dry area))	
Certifications and licenses Housing		
Certifications and licenses Switching element		

Switches

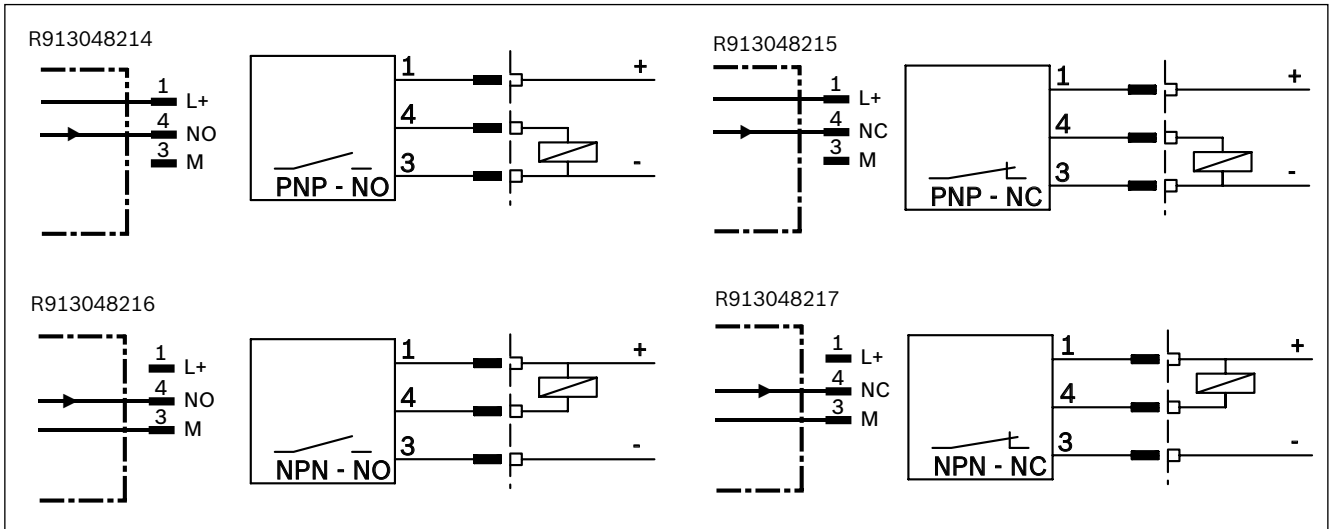
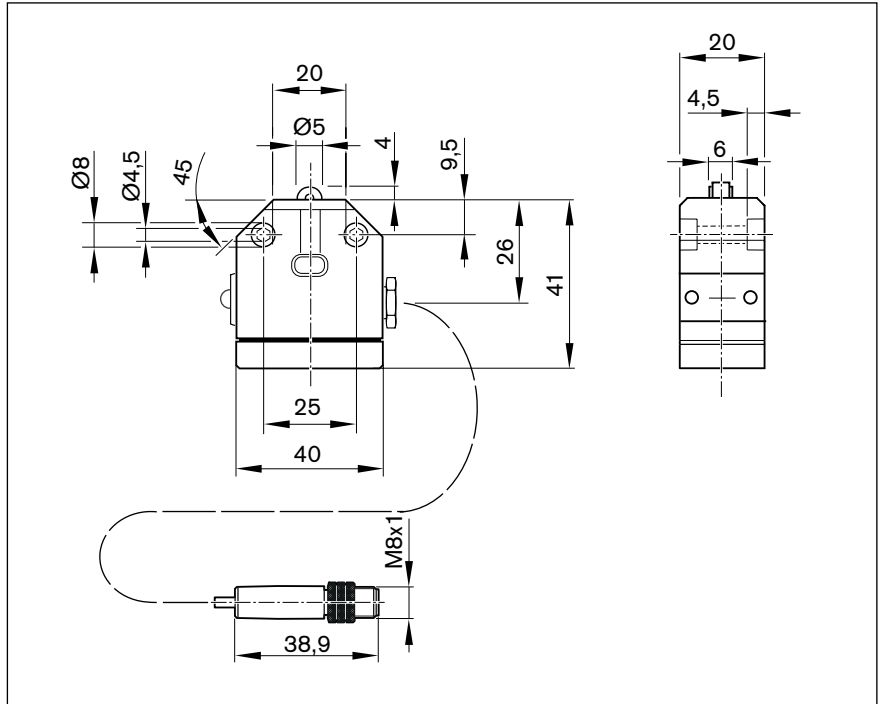
Mechanical switch with M8x1 plug



Material numbers/technical data

Use	Limit switch	Reference switch	Limit switch	Reference switch
Material number	R913048215	R913048214	R913048217	R913048216
Name	BNS 819-X1002-99-R-10	BNS 819-X1001-99-R-10	BNS 819-X1004-99-R-10	BNS 819-X1003-99-R-10
Functional principle	mechanical, roller			
Operating voltage	10 - 30 VDC			
Load current	≤ 200 mA			
Switching function	PNP NC	PNP NO	NPN/NC	NPN/NO
Connection type	Cable 0.2 m and plug M8 x 1, 3-pin with knurled screw			
Function indicator	-			
Short-circuit protection	-			
Reverse polarity protection	-			
Switching frequency	3.3 Hz			
Max. perm. starting speed	1 m/s			
Suitable for drag chains ¹⁾	-			
Torsion-resistant ¹⁾	-			
Weld spark-resistant ¹⁾	-			
Cable cross-section ¹⁾	3x0.14 mm ²			
Cable diameter D ¹⁾	4.3 ±0.2 mm			
Static bending radius ¹⁾	12 mm			
Dynamic bending radius ¹⁾	12 mm			
Bending cycles ¹⁾	-			
Ambient temperature	-5°C to +70°C			
Protection type	IP65			
B10d value	5x10 ⁶ (wet area); 10x10 ⁶ (dependent on current load (dry area))			
Certifications and approvals ²⁾	  			

¹⁾ Technical data only for the cast-on connection line at the mechanical switch.

The available extension cables offer even better performance, e.g., when using a cable drag chain (see following pages).

²⁾ No  certificate is required to introduce these products to the Chinese market.

Extensions

Assembled on one end

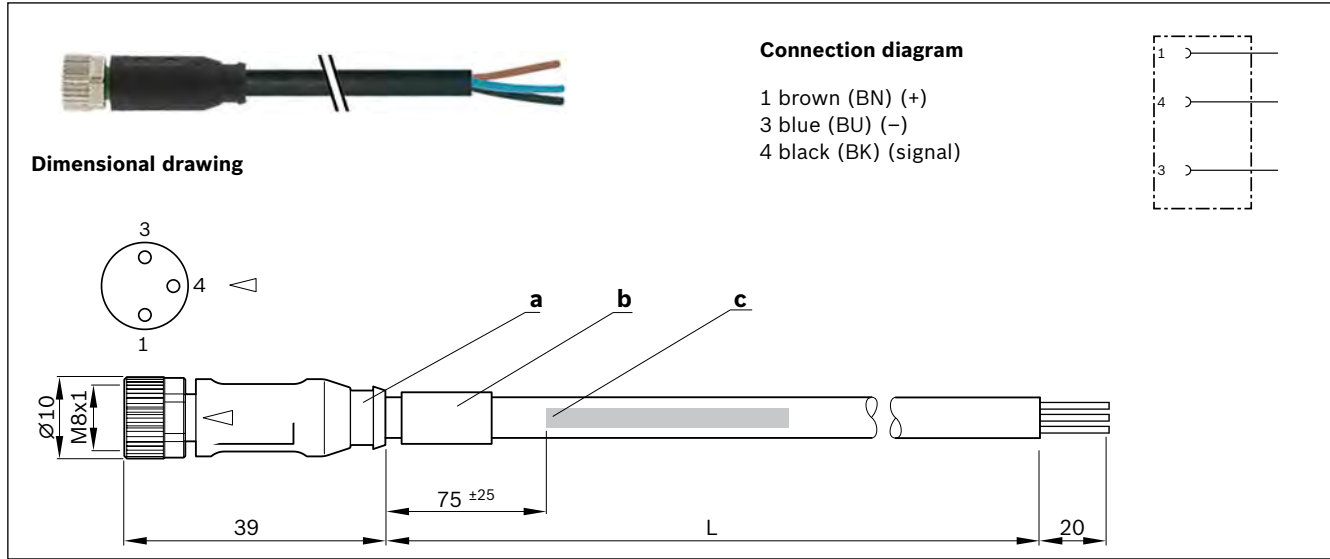

Material numbers

Use	Extension cable		
Material number	R911344602	R911344619	R911344620
Name	7000-08041-6500500	7000-08041-6501000	7000-08041-6501500
Length (L)	5.0 m	10.0 m	15.0 m
Connector Type 1	M8x1 3-pin straight female connector		
2nd Connection type	Unassembled cable end		

- a) Contour for 6.5 mm corrugated tube (inner diameter)
- b) Cable grommet
- c) Cable printing per printing specification

Assembled on both ends

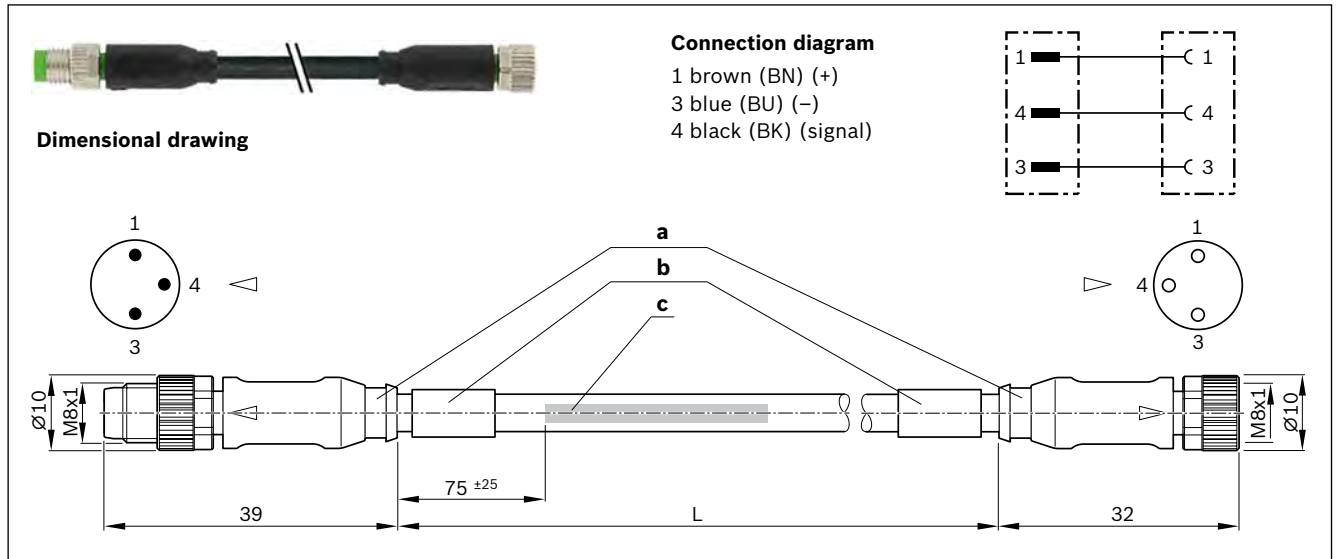

Material numbers



Use	Extension cable				
Material number	R911344621	R911344622	R911344623	R911344624	R911344625
Name	7000-88001-6500050	7000-88001-6500100	7000-88001-6500200	7000-88001-6500500	7000-88001-6501000
Length (L)	0.5 m	1.0 m	2.0 m	5.0 m	10.0 m
Connector Type 1	M8x1 3-pole straight female connector				
2nd Connection type	Straight plug, M8x1, 3-pin				

Technical data for extensions pre-assembled on one or two sides

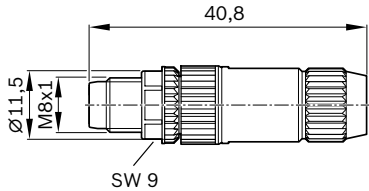
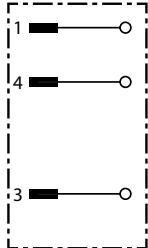
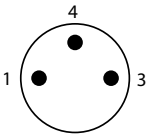

Function indicator	-
Operating voltage indicator	-
Operating voltage	10–30 V DC
Type of cable	PUR black
Suitable for drag chains	✓
Torsion-resistant	✓
Weld spark-resistant	✓
Cable cross-section	3x0.25 mm ²
Cable diameter D	4.1 ± 0.2 mm
Static bending radius	≥ 5xD
Dynamic bending radius	≥ 10xD
Bending cycles	> 10 mil.
Max. permissible travel velocity	3.3 m/s for 5 m travel distance (typ.), up to 5 m/s for 0.9 m travel distance
Max. permissible acceleration	≤ 30 m/s ²
Ambient temperature fixed ext.	-40°C to +85°C
Ambient temperature flexible ext.	-25°C to +85°C
Protection type	IP68
Certifications and Licenses	

- a) Contour for 6.5 mm corrugated tube (inner diameter)
- b) Cable grommet
- c) Cable printing per printing specification

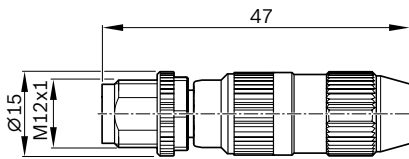
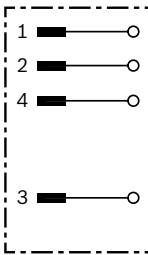
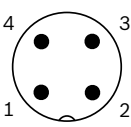
Connectors

	Dimensional drawing	Connection diagram	Connector side view
 R901388333			
 R901388352			

Material numbers/technical data

Use	Male connector, single	
Material number	R901388333	R901388352
Name	7000-08331-0000000	7000-12491-0000000
Version	straight	
Operating current per contact	max. 4 A	
Operating voltage	max. 32 V AC/DC	
Connection type	Straight plug, M8x1, 3-pin, IDC, self-locking screw	Straight plug, M12x1, 4-pin, IDC, self-locking screw
Function indicator	-	
Operating voltage indicator	-	
Connection cross-section	0.14 ... 0.34 mm ²	
Ambient temperature	-25°C to +85°C	
Protection type	IP67 (inserted and locked)	
Certifications and Licenses	  	

Adapters



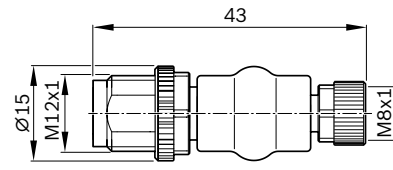

R911344591

Dimensional drawing

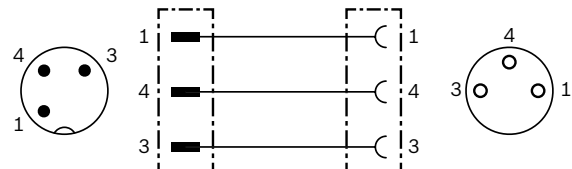

Connection diagram





R911344592

Dimensional drawing

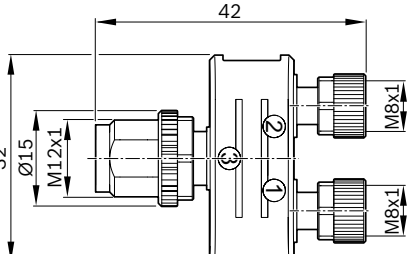



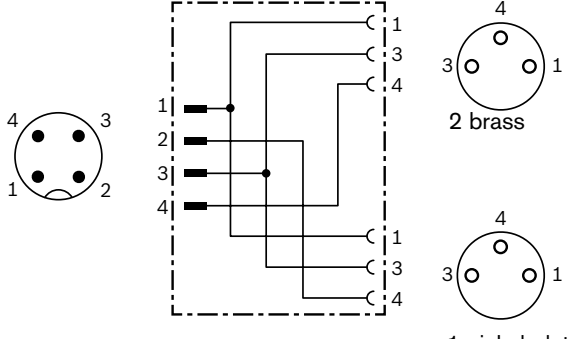

Connection diagram



2 brass

1 nickel-plated

Material numbers/technical data

Use	Adapters	Adapter or distributor
Material number	R911344591	R911344592
Name	7000-42201-0000000	7000-41211-0000000
Version	straight for 1 sensor	straight, for 1 - 2 sensors
Operating current per contact	max. 4 A	
Operating voltage	max. 32 V AC/DC	
Connector Type 1	Straight female connector, M8x1, 3-pin, self-locking screw thread	2 X straight female connectors, M8x1, 3-pin, self-locking screw thread
2nd Connection type	Male connector, straight, M12x1, 3-pin Self-locking screw thread	Straight plug, M12x1, 4-pin, IDC, self-locking screw thread
Function indicator	-	
Operating voltage indicator	-	
Connection cross-section	-	
Ambient temperature	-25°C to +85°C	
Protection type	IP67 (inserted and locked)	
Certifications and Licenses		  

Passive distributor

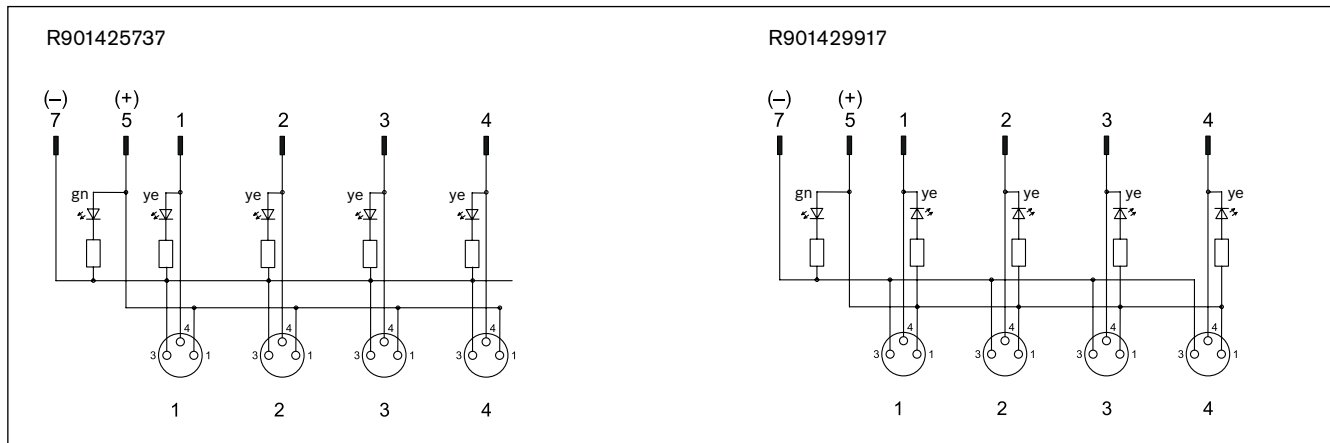
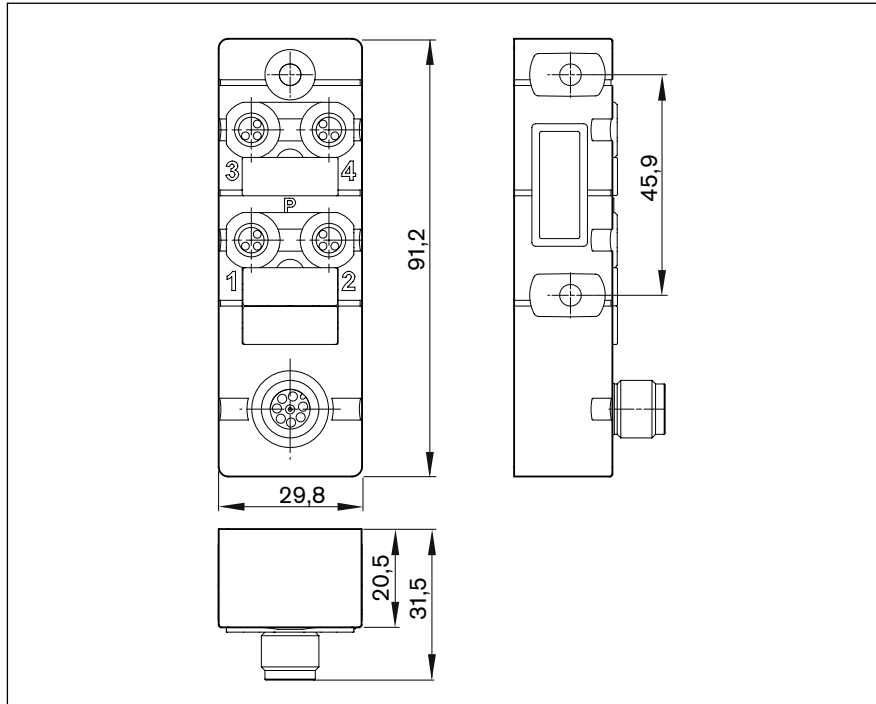

Material numbers/technical data

Use	Passive distributor		
Material number	R901425737	R901429917	R911344592
Name	8000-84070-0000000	8000-84071-0000000	
Version	straight, for 1 - 4 sensors		
Operating current per contact	max. 2 A		
Operating voltage	24 V DC		
Switching logic	PNP	NPN	
Connector Type 1	4x female connector, straight, M8x1, 3-pin Self-locking screw thread		
Connector type 2	Straight plug, M12x1, 8-pin, IDC, self-locking screw thread		
Function indicator	✓		
Operating voltage indicator	✓		
Connection cross-section	-		
Ambient temperature	-20°C bis +70°C		
Protection type	IP67 (inserted and locked)		
Certifications and licenses			

For technical data and dimensional drawings, see adapter

Accessories for passive distributors

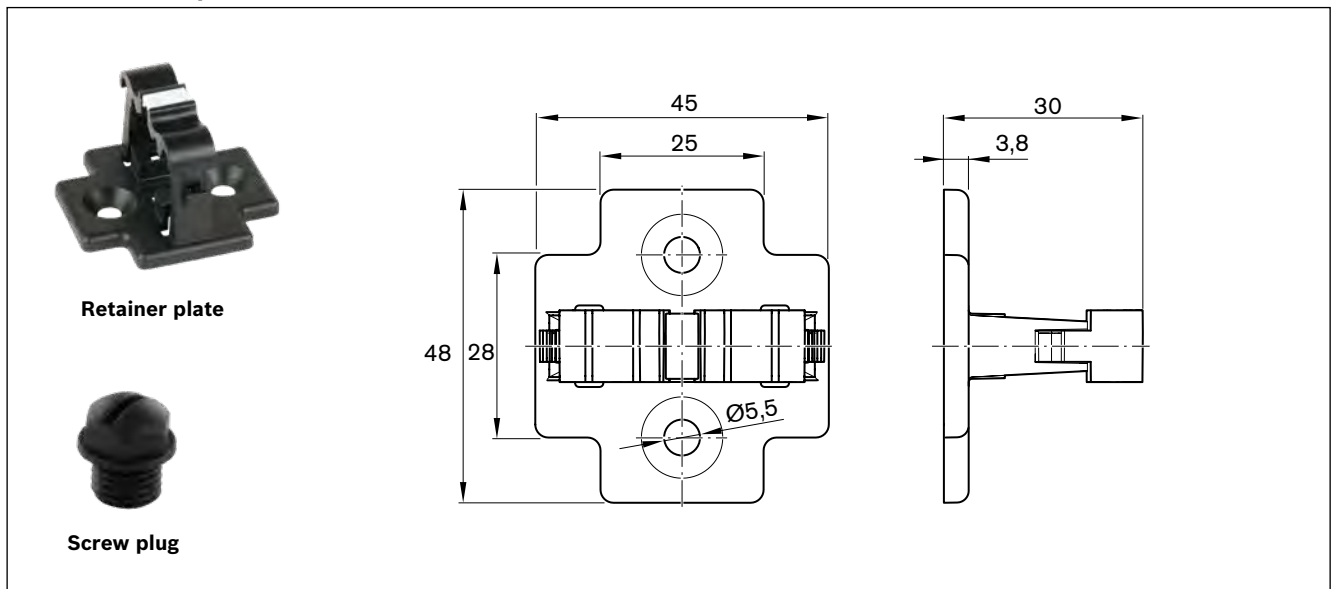

Material numbers/technical data



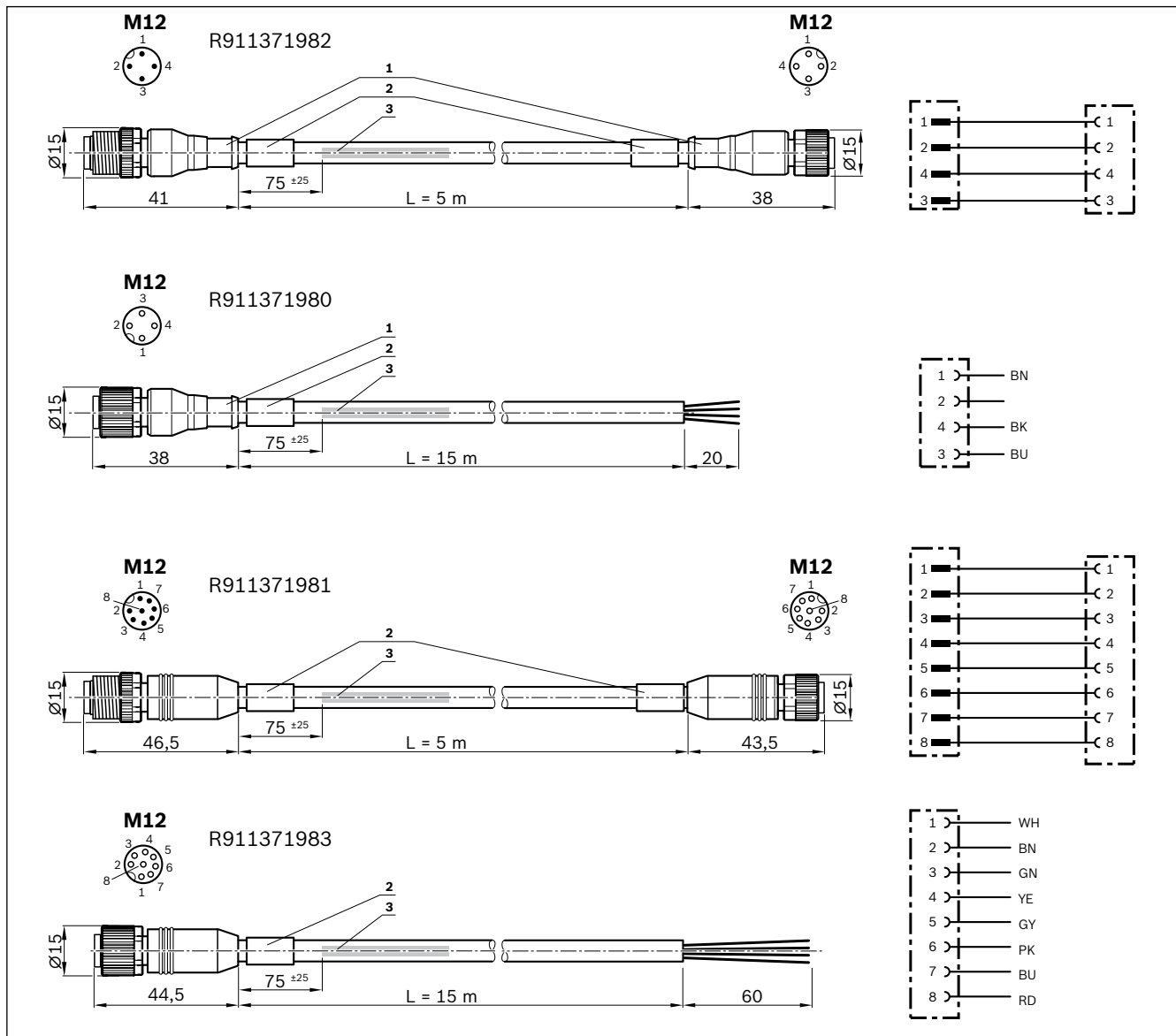
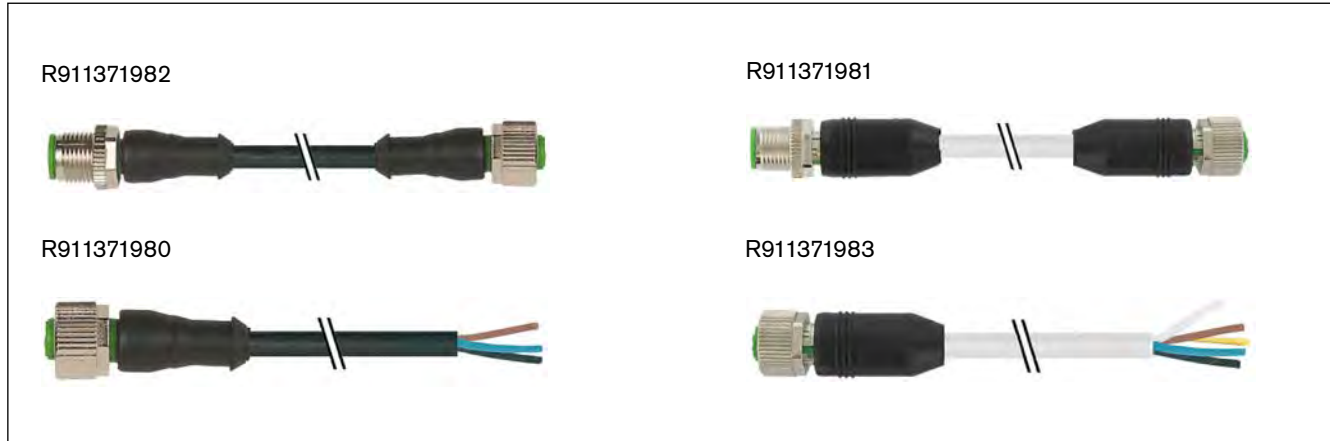

Use	For passive distributor R911344592	For passive distributors R901425737/ R901429917
Retainer plate	R913047341	-
Name	7000-99061-0000000	-
Set	1 unit	-
Screw plug	-	R913047322
Name	-	3858627
Set	-	10 units

Extensions for Passive Distributors



1) Contour for conduit pipe with inner diameter of 10
 2) Cable grommet
 3) Cable print per ordering specification 7000-08001

Material numbers/technical data

Use	Extension cable for passive distributor R911344592		Extension cable for passive distributors R901425737 / R901429917	
Material number	R911371982	R911371980	R911371981	R911371983
Name	7000-40021-6540500	7000-12221-6541500	7000-48001-3770500	7000-17041-3771500
Length	5.0 m	15.0 m	5.0 m	15.0 m
Connector Type 1	Female connector, straight, M12x1, 4-pin		Female connector, straight, M12x1, 8-pin	
Connector type 2	Straight plug, M12x1, 4-pin	Unassembled cable end	Straight plug, M12x1, 8-pin	Unassembled cable end
Function indicator	-			
Operating voltage indicator	-			
Type of cable	PUR black		PUR gray	
Operating voltage	30 V AC/DC			
Operating current per contact	max. 4 A per contact		max. 2 A per contact	
Suitable for drag chains	✓			
Torsion-resistant	✓			
Weld spark-resistant	✓			
Cable cross-section	4x0.34 mm ²		8x0.34 mm ²	
Cable diameter D	4.7 +/- 0.2 mm		6.2 +/- 0.3 mm	
Static bending radius	≥ 5 x D			
Dynamic bending radius	≥ 10 x D			
Bending cycles	> 10 mil.			
Max. permissible travel velocity	3.3 m/s for 5 m travel distance (typ.), up to 5 m/s for 0.9 m travel distance			
Max. permissible acceleration	≤ 30 m/s ²			
Ambient temperature fixed ext.	-40°C to +80°C (90°C max. 10,000 h)			
Ambient temperature flexible ext.	-25°C to +80°C (90°C max. 10,000 h)			
Protection type	IP67 (inserted and locked)			
Certifications and licenses	    			

Combination examples

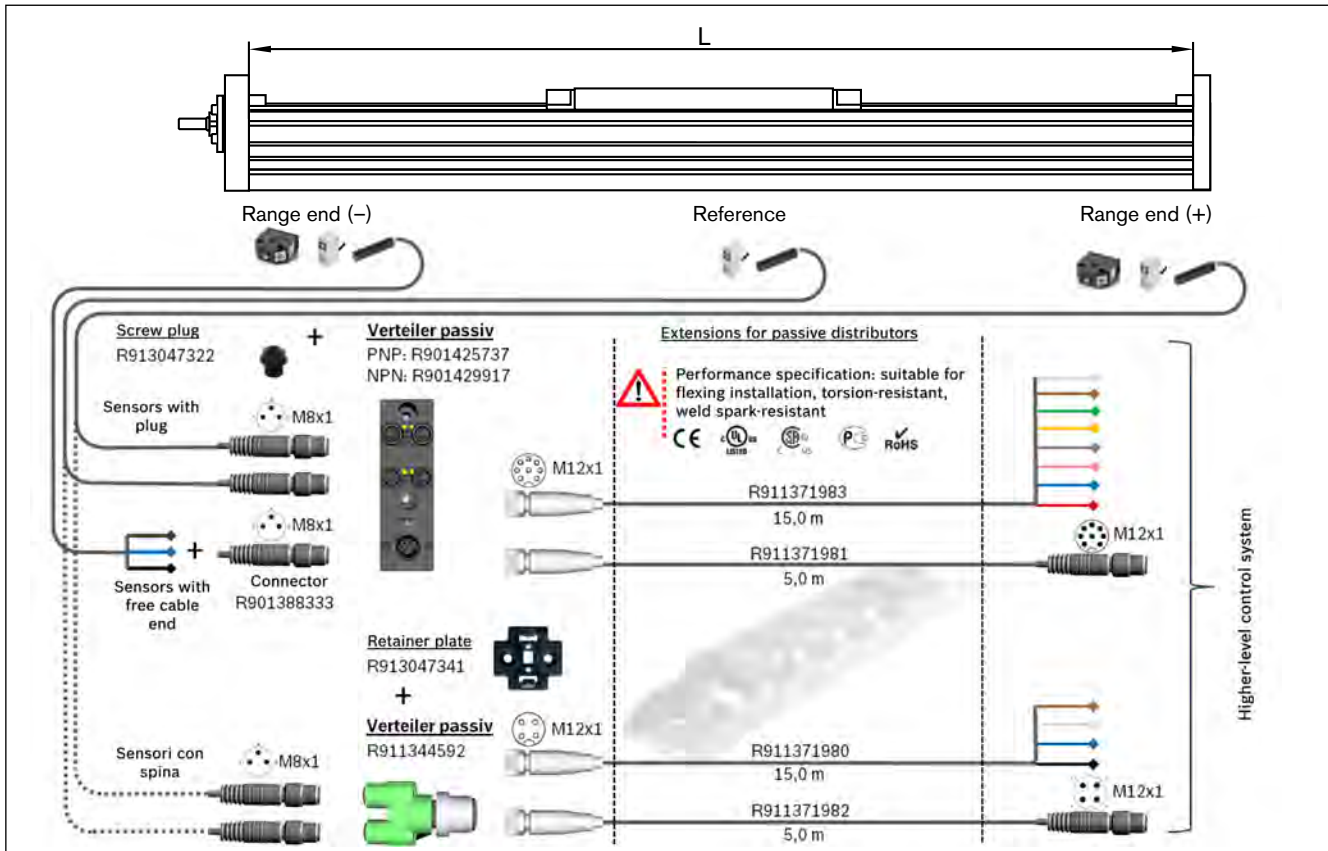
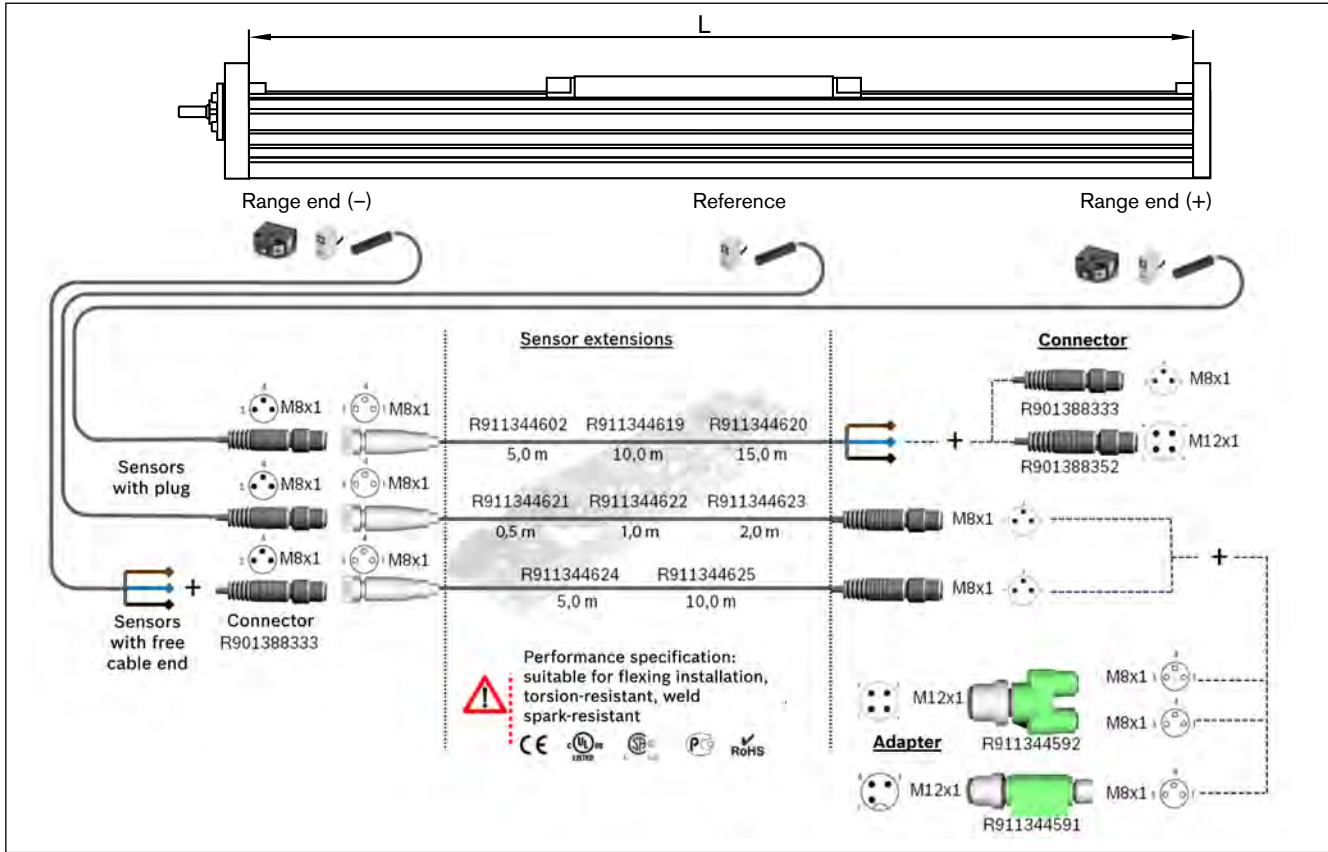

Attachments and accessories

Integrated measuring system IMS-A

The IMS-A measuring system offers the following advantages:

- ▶ No additional space required.
- ▶ No additional mounting surfaces required for the measuring system.
- ▶ No measurement inaccuracies due to parallelism offset between the measuring system and the guide system.
- ▶ Full integration of the measuring system components into the guide means no complex mounting or tuning work is needed.
- ▶ The runner block, scanner and guide rail with scale can be replaced individually during servicing.
- ▶ Interfaces: HIPERFACHE or DRICE-CLiQ.
- ▶ Connecting cable on the side of the carriage.

Inductive Measuring Principle

- ▶ Contact-free scanning ensures zero maintenance
- ▶ Resistant to water, oil, dust, shavings, etc.
- ▶ Insusceptible to magnetic fields

Absolute Measuring Principle

- ▶ Precise, absolute position detection thanks to an additional absolute code band
- ▶ No battery necessary for buffering the absolute information

Scale

- ▶ The scales (**8/9**) are integrated in the guide rail.
- ▶ These consist of a steel mesh band (division period = 1,000 μm)
- ▶ An absolute code band is integrated for absolute position detection.
- ▶ The cover (**10**) (stainless-steel band) protects the scale (**8/9**) from contamination.

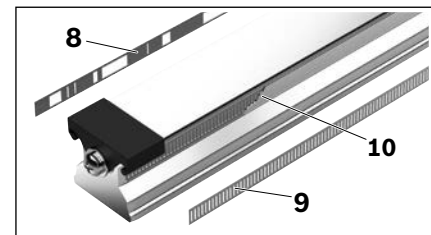

Delivery form MKx-xxx-NN-3

- ▶ IMS-A connector is always on the right (note the direction of vision)



Direction of vision

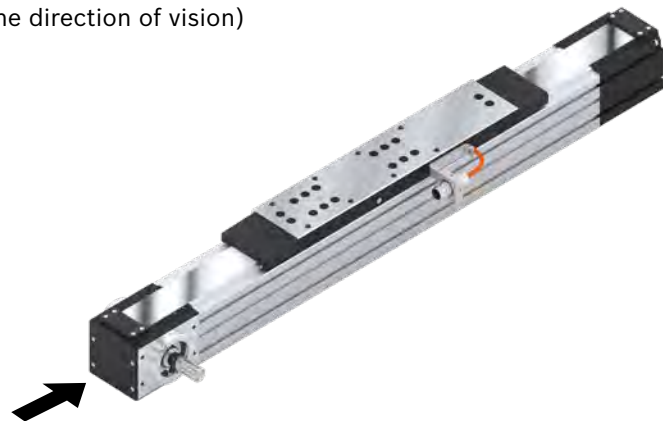

Direction of vision

Structural design

- 1 Guide rail with scale, reference marks or absolute code band
- 2 Front seal
- 3 Support plate
- 4 Scanner
- 5 Adapter plate (fixed to the runner block)
- 6 Runner block
- 7 Cables and connectors

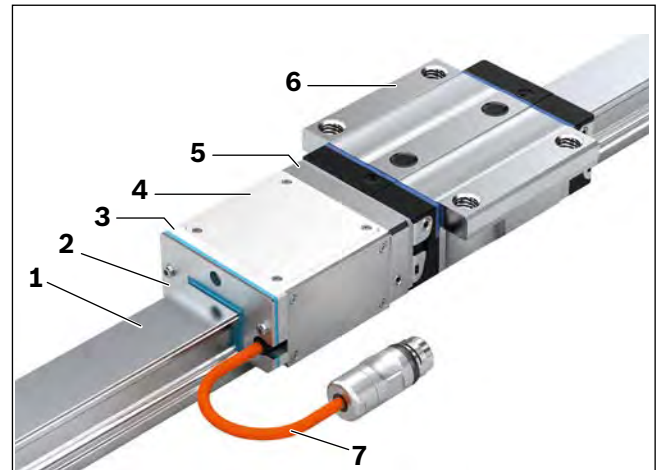

Technical data

System accuracy

Scale	Scanner	
	Interpolation accuracy (μm)	Repeatability (μm)
Accuracy class $\pm 5 \mu\text{m}/\text{m}$	± 0.75	± 0.25

The precise accuracy of the scale is provided in the included measurement report.

To determine the accuracy of the system, the accuracy classes of the scale, the interpolation accuracy and repeatability are to be added together.

IMS-A		
Interface (signal)	HF	DQ
Resolution of the digital interface (μm)	1.250	0.025
Dissolvability of the 1 V _{pp} / 40 μm signal (μm)	0.025	-

Technical data

	Ball rail system	Comment
Maximum travel speed	5 m/s	
Acceleration a_{max}	500 m/s ²	
EMC	Interference immunity: EN 61326-1: 2006 Emitted interference: EN 61000-6-2, Class B	CE-marking
RoHS compliant	yes	
UL compliant	yes	

For further information, see the "Integrated Measuring System IMS" catalog

Additional information

Operating conditions

Normal operating conditions

Ambient temperature with Rexroth servo motor	0 °C ... 40 °C, above 40 °C loss of performance
Ambient temperature for mechanical system (no dropping below dew point)	-10 °C ... 50 °C
Travel $s_{\min}^{1)}$	See "Technical data" tables MKK/MKR/MLR
Soiling	Not permissible

¹⁾ Minimum travel to ensure a reliable lubrication distribution.

Required and supplementary documentation

For further instructions and information, please refer to the documentation for this product.

You can find PDF files of these documents on the Internet at www.boschrexroth.com/mediadirectory.

We would also be happy to send you the documents that you want.

If you are unsure about using this product, please contact Bosch Rexroth.

Lubrication-MKx-165-NN-2

Note on lubrication

Linear modules (MKx-165-NN-2) come with initial greasing with Dynalub 510 and are only designed for grease lubrication using a manual grease gun. Maintenance is limited to the maintenance lubrication of the integrated Rexroth ball rail system and the Rexroth ball screw assembly (on MKK) via one of the two funnel-type lube nipples. (DIN 3405-A M6)

⚠ Do not use lubricants with solid particles (e.g. graphite or MoS₂ additives).

⚠ For short stroke lubrication (< s_{min} mm), please consult us.

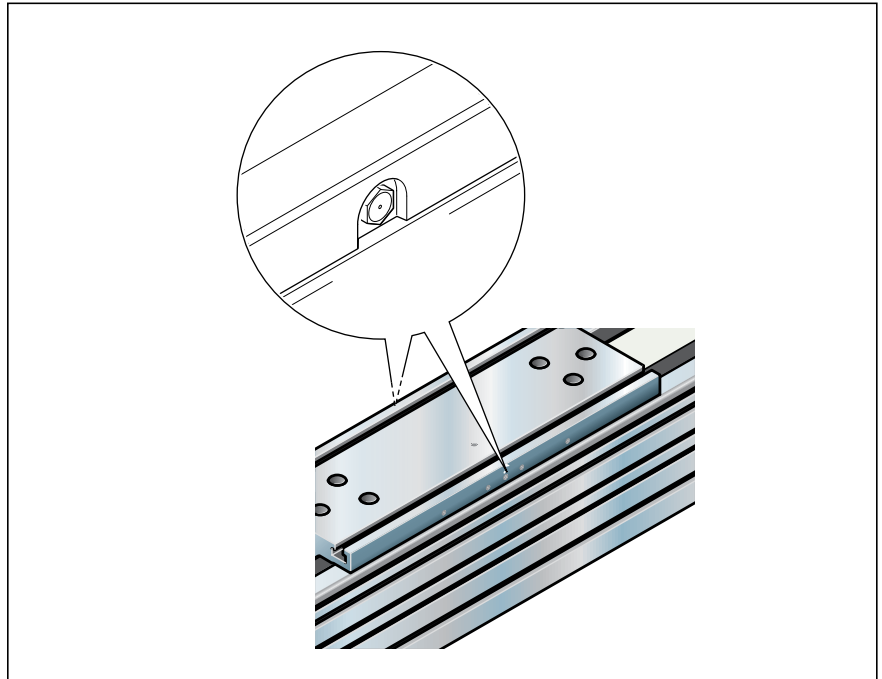

Recommended lubricants

For maintenance lubrication and maintenance lubrication intervals, see the linear module instructions

MKK/MKR	Grease (DIN)	Consistency class DIN 51818	Recommended grease
-165	KP2K-20 (DIN 51825)	NLGI 2	Dynalub 510

Grease

Consistency class NLGI 2 as per DIN 51818

We recommend:

Dynalub 510 (Bosch Rexroth)
 Cartridge (400 g) R341603700
 Container (25 kg) R341603500

Can still be used

Elkalub GLS 135 / N2 (Chemie-Technik)
 Tribol GR 100-2 PD (Castrol)

Lubrication-MLR-xxx-NN-3

Linear modules with cam roller guide (MLR) are designed for oil lubrication. With initial greasing on delivery.

MLR	Lube nipple	Oil
-080	DIN 3405-A M6	ISO VG 1000
-110		

Accessories (nozzle pipe) for manual grease gun, see chapter "Attachments and accessories".

Lubrication MKx-xxx-NN-3

Lubrication version	LSS		LPG	
Size	MKx-065 / -080 / -110 / -140 / -145	MKx-040	MKx-065 / -080 / -110 / -140 / -145	MKx-040
Basic lubrication	Dynalub 510	Dynalub 520	Preserved, basic lubrication required (see instructions)	
Consistency class	NLGI 2 (DIN 51818)	NLGI 00 (DIN 51818)	-	
Identification	KP2K-20 (DIN 51825)	GP00K-20 (DIN 51826)	-	
Lubrication with grease gun	yes	yes	yes	
Prepared for connection to central lubrication systems	-			
Recommended lubricants	Dynalub 510 (Grease lubricant) (NLGI2 DIN 51818)	Dynalub 520 (Liquid grease) (NLGI00 DIN 51818)	Dynalub 510 (Grease lubricant) (NLGI2 DIN 51818)	Dynalub 520 (Liquid grease) (NLGI00 DIN 51818)
Features	<ul style="list-style-type: none"> • Good water resistance • Corrosion protection • Temperature range: -20 °C to +80 °C 			
Material numbers	R3416 037 00 (400 g cartridge)	R3416 043 00 (400 g cartridge)	R3416 037 00 (400 g cartridge)	R3416 043 00 (400 g cartridge)
	R3416 035 00 (25 kg container)	R3416 042 00 (5 kg bucket)	R3416 035 00 (25 kg container)	R3416 042 00 (5 kg bucket)
Alternative lubricants	<ul style="list-style-type: none"> • Tribol GR 100-2 PD • Elkalub GLS 135/N2 	<ul style="list-style-type: none"> • Tribol GR 100-00 PD • Elkalub GLS 135/N00 	<ul style="list-style-type: none"> • Tribol GR 100-2 PD • Elkalub GLS 135/N2 • Tribol GR 100-00 PD • Elkalub GLS 135/N00 • Dynalub 520 • Klüberplex BEM 34-132 	<ul style="list-style-type: none"> • Tribol GR 100-00 PD • Elkalub GLS 135/N00
Alternative lubricants with H1 approval	-		<ul style="list-style-type: none"> • Berulub FG H2 SL • Cassida Grease EPS2 • VP 874 	<ul style="list-style-type: none"> • Berulub FB 34-00 • Elkalub GLS 367/N00

 Notes on lubrication

- ▶ Follow the product instructions.
- ▶ Do not use lubricants with solid particles (e.g. graphite or MoS₂).
- ▶ If using different lubricants than the ones specified, relubrication intervals may be shorter and performance may decrease with short stroke and load ratio; in addition, chemical interactions can take place between the plastics, lubricants and preservative agents. Single-line central lubrication systems also need to be able to pump these lubricants.
- ▶ If using a central lubrication system, make sure all lines and elements are filled with lubricant all the way to the connection to the consumer (carriage) and that there are no air bubbles.
- ▶ Lubricant reservoirs should contain an agitator to ensure the lubricant can flow (avoids hardening in the reservoir).
- ▶ For relubrication, it is not possible to switch from grease to oil lubrication and vice-versa.
- ▶ If environmental factors such as contamination, vibrations, impact loads, etc. are present, we recommend shorter relubrication intervals. Even under normal operating conditions, relubrication is required every two years due to grease aging.
- ▶ Rexroth recommends piston distributors by SKF. These should be installed as close to the carriage lube fittings as possible. Avoid long lines (no longer than 1 m) and narrow line diameters. Install the lines at a gradient.
- ▶ If other consumers are connected to the single-line lubrication system, the weakest link in this chain determines the lubrication cycle.
- ▶ Excess lubricant can accumulate inside of the linear module or flow out and may lead to contamination of the environment.
- ▶ Never put linear modules into operation without basic lubrication.

	LCF	LCO
	MKx -040 / -065 / -080 / -110 / -140 / -145	MKx -040 / -065 / -080 / -110 / -140 / -145
	required, see instructions	required, see instructions
	NLGI 00 (DIN 51818)	-
	GP00K-20 (DIN 51826)	-
	-	-
	<ul style="list-style-type: none"> only via single-line piston distributor system smallest permissible piston distributor size: MKx -040, -065, -080, -145: 0.2 cm³; MKx -110, -140: 0.3 cm³ 	<ul style="list-style-type: none"> only via single-line piston distributor system smallest permissible piston distributor size: MKx -040, -065: 0.2 cm³; MKx -080: 0.4 cm³; MKx -110, -140, -145: 0.6 cm³
	Dynalub 520 (liquid grease) (NLGI00 DIN 51818)	Shell Tonna S3 M220 (lubricant oil)
	<ul style="list-style-type: none"> Good water resistance Corrosion protection Temperature range: -20°C to +80°C 	<ul style="list-style-type: none"> Special demulsifying oil CLP or CGLP as per DIN 51517-3 for machine bed tracks and tool guides A blend of highly refined mineral oils and additives Can be used even when mixed with significant quantities of metalworking fluids
	R3416 043 00 (400 g cartridge)	-
	R3416 042 00 (5 kg bucket)	-
	<ul style="list-style-type: none"> Tribol GR 100-00 PD Elkalub GLS 135/N00 	<ul style="list-style-type: none"> Special demulsifying oil CLP or CGLP as per DIN 51517-3 for machine bed tracks and tool guides
	-	-

⚠ Use of lubricants with H1 approval:

Loss of H1 approval.

H1 lubricants or release agents (preservative agents) only have H1 approval if they are separated and unmixed (including at the lubrication point). A blend of two H1 approval lubricants or separating agents does not have H1 approval.

No approval or authorization for use in the food industry.

Because of the use of H1 lubricants, the linear modules do not have authorization or approval for the food industry.

Components lubricated at the factory.

Components lubricated by the manufacturer at the factory, such as deep-groove ball bearings, do not use H1 lubricants.

⚠ Linear modules with Dynalub 520 (NLGI 00 class) initial greasing must not be pre-lubricated with lubricant of consistency class NLGI 2!

For grease re-lubrication quantity and re-lubrication interval ⇒ Instructions linear modules

Lube connection

Linear module	Lube nipple (with "LSS / LPG lubrication")	Connector (with "LCF / LCO lubrication")
MKK/MKR-040	DIN 3405-A M3	See dimension drawing
MKK/MKR-065 / -080 / -110 / -140 / -145	DIN 3405-A M6	

Straight connectors¹⁾ for plastic tubes and metal pipes

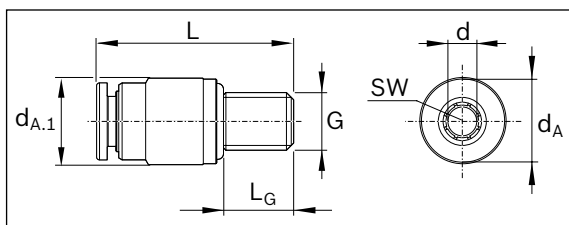

Material number	Dimensions (mm)							Mass (g)
	d_A	$d_{A.1}$	$d_{\pm 0.1}$	G	L	L_G	A/F	
R341707309 ²⁾	6.5	6.5	3	M3	16.0	5	1.5	1.6
R341707509	9	9	4	M6	24.5	8	2.5	4.9

¹⁾ Max. lubrication pressure: 30 bar (exerting slow pressure with manual grease gun)

²⁾ MKK/MKR-040

Additional information

Documentation

Standard report Option 001

The standard report serves to confirm that the checks listed in the report have been carried out and that the measured values lie within the permissible tolerances.

Checks listed in the standard report:

- Functional checks of mechanical components
- Functional checks of electrical components
- Design as per order confirmation

Measurement of frictional torque of complete system

Option 002 (includes Option 001)

The moment of friction is measured over the entire travel range.

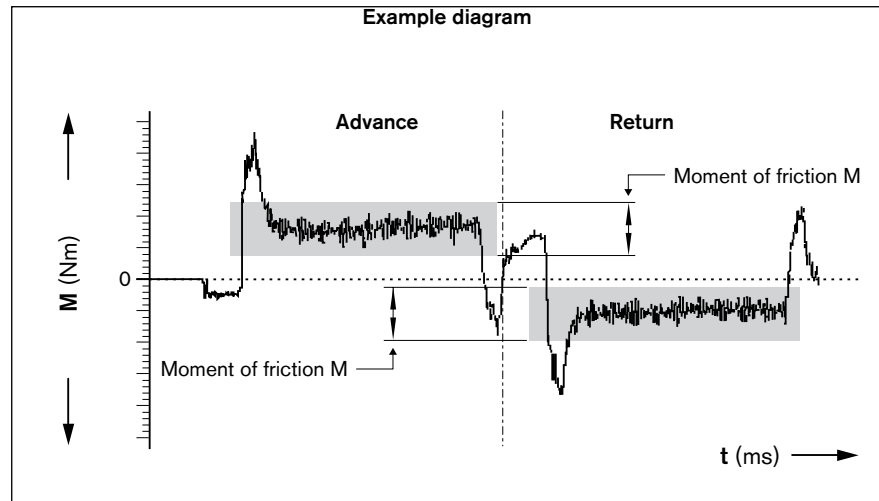

Lead deviation of the ball screw assembly drive for linear modules MKK

Option 003 (includes Option 001)

In addition to graphical representation (see illustration), a measurement report is supplied in table form.

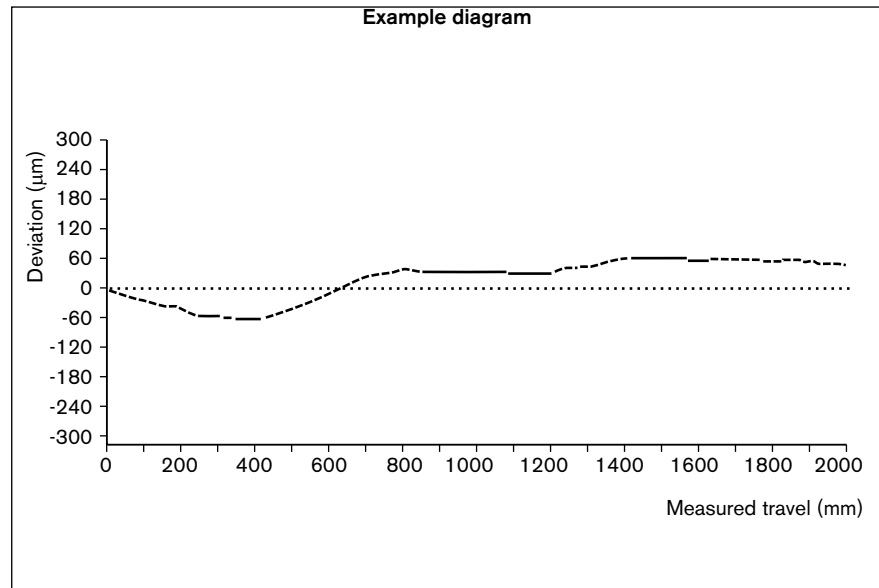

Positioning accuracy

as per VDI/DGQ 3441
option 005 (includes Option 001)

Measurement points are selected at irregular intervals along the travel distance. This enables even periodical deviations to be detected during positioning.
Each measurement point is approached several times from both sides.
This provides the following parameters.

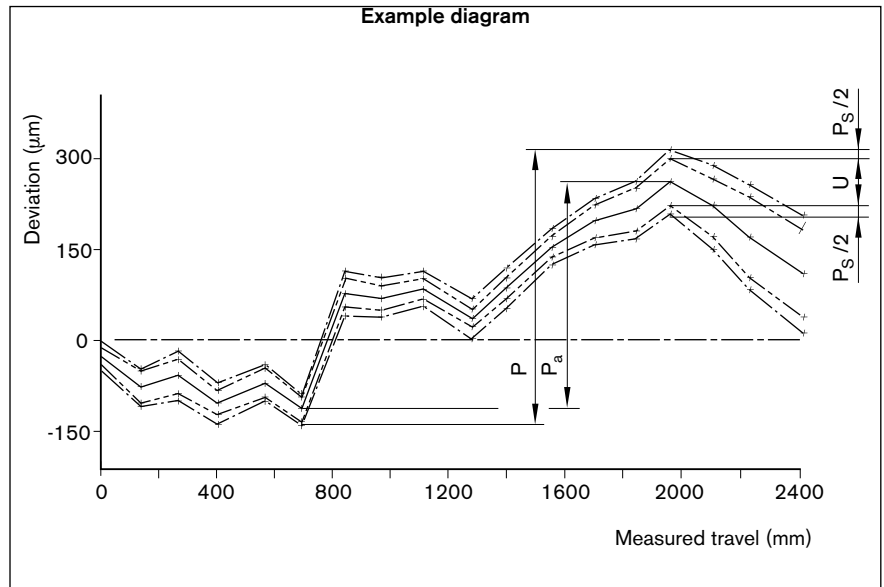

Positional uncertainty P

The positional uncertainty equals the total deviation.
It encompasses all the systematic and random deviations in relation to positioning.

Positional uncertainty is a parameter for the positioning accuracy and corresponds to the total deviation. It encompasses all the systematic and random deviations in relation to positioning.

Positional uncertainty takes the following characteristic values into consideration:

- Positioning deviation
- Reversal range
- Position variation range

Positioning deviation P_a

The positioning deviation equals the maximum difference arising between the mean values of all the measurement points.
It describes systematic deviations.

Reversal range U

The reversal range corresponds to the difference in mean values of the two approach directions. The reversal range is determined at every measurement point.
It describes systematic deviations.

Position variation range P_s

The position variation range describes the effects of random deviations.
It is determined at every measurement point.

Additional information

Parameterization (start-up)

The nameplate contains reference information on the production of the linear motion system as well as technical start-up parameters.

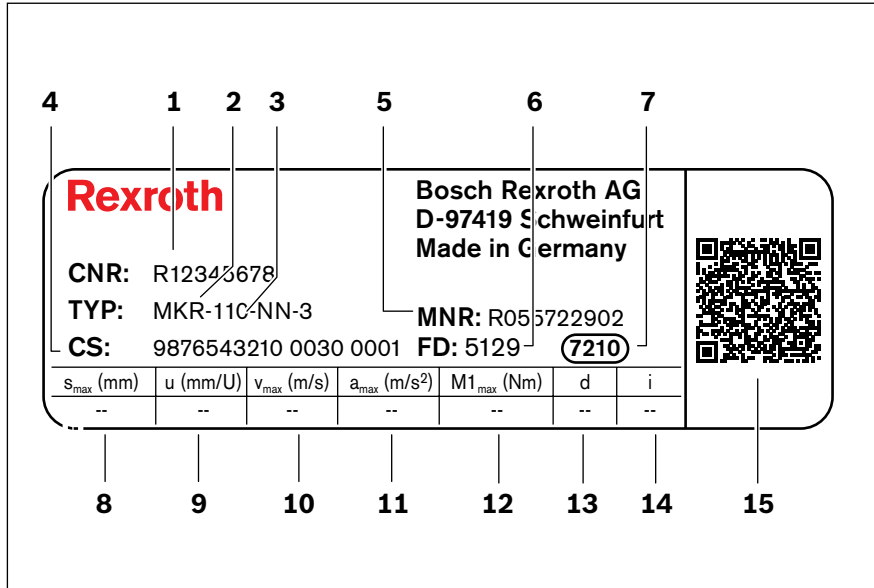

1	CNR	Customer's material number
2	TYP	Short product name
3	110	Size
4	CS	Customer information
5	MNR	Material number
6	FD	Date of manufacture
7	7210	Manufacturing location
8	s_{max}	Maximum travel range
9	u	Feed constant without motor attachment
10	v_{max}	Maximum speed
11	a_{max}	Maximum acceleration rate
12	$M1_{max}$	Maximum drive torque at motor journal
13	d	Direction of motor rotation to move in positive (+) direction CW = clockwise CCW = counterclockwise
14	i	Gear ratio
15		QR code

Calculation principles

Calculation principles	164
Length calculation	164
Note on dynamic load capacities and moments	165
Maximum permissible load	166
Linear guide life	166
Service life of ball screw assembly or the fixed bearing	167
Drive dimensioning	168
Basic principles	169
Drive dimensioning with motor shaft as reference point	170
General motor preselection	172
Sample calculations	174
Sample calculation MKK	174
Sample calculation MKR	177
 For the abbreviations refer to the "Abbreviations" chapter	 180

Length calculation of the linear motion system

For length calculation values, see the section titled "Technical data" for the desired linear module (MKK/MKR/MLR)

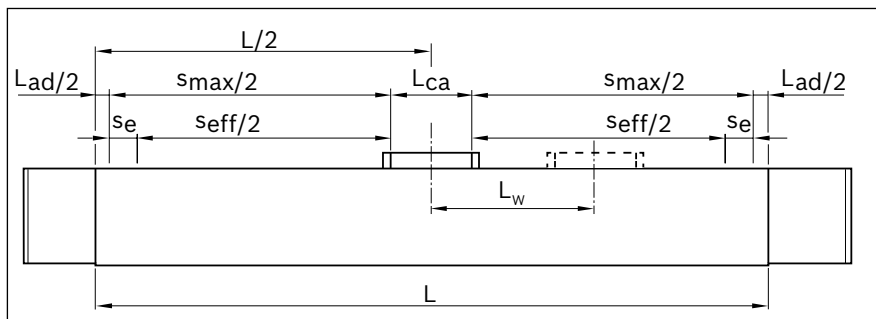

$$L = s_{eff} + 2 \cdot s_e + L_{ca} + L_{ad} + L_w$$

MKK -165

$$L = (s_{eff} + 2 \cdot s_e) \cdot 1.17^* + L_{ca} + L_{ad}$$

* for cover with bellows

Effective stroke

$$s_{eff} = s_{max} - 2 \cdot s_e$$

Stroke: maximum distance from carriage center to the outer-most switch activation points.

Excess travel: Excess travel must be greater than braking distance.

The acceleration travel can be adopted as the guideline value for the braking distance.

Mass of the linear system

Weight calculation:

- ▶ without motor
- ▶ without switch mounting
- ▶ without motor attachment

$$m_s = k_{g\,fix} + k_{g\,var} \cdot L + m_{ca}$$

Note on dynamic load capacities and moments

Suitable loads

Regarding the desired service life, general loads for F_{mgw} , F_{mbs} should not exceed around 20% of the dynamic characteristic values (C_{gw} , C_{bs}). See "Planning" chapter. Do not exceed the technical data for the linear motion system.

Determination of the dynamic load capacities and moments is based on a total travel of 100,000 m. Often only 50,000 m of total travel are actually stipulated. For comparison: Multiply values C , M_t and M_L by a factor of 1.26.

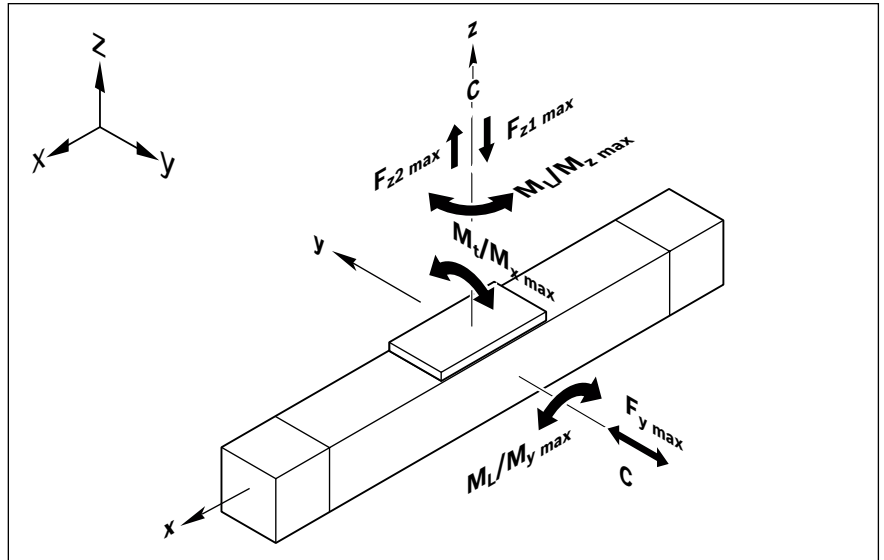

Application point of the effective force (z_1)

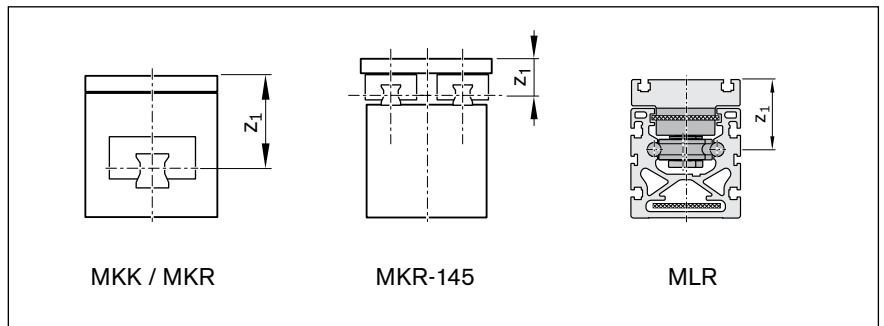

Modulus of elasticity E

$E = 70\,000 \text{ N/mm}^2$

Deflection

A particular feature of linear modules is that they can be installed as cantilevered axes. Deflection must, however, be taken into consideration: It limits the possible load. If the maximum permissible deflection is exceeded, additional supports must be provided. The maximum permissible deflection f_{max} depends on the length L and the load F .

⚠ Do not mount or support the linear module by the end blocks or end enclosures!

⚠ f_{max} must not be exceeded! If high system dynamics are required, supports must be provided every 300 to 600 mm. (For f_{max} values, see "Technical data" chapter of the respective linear module)

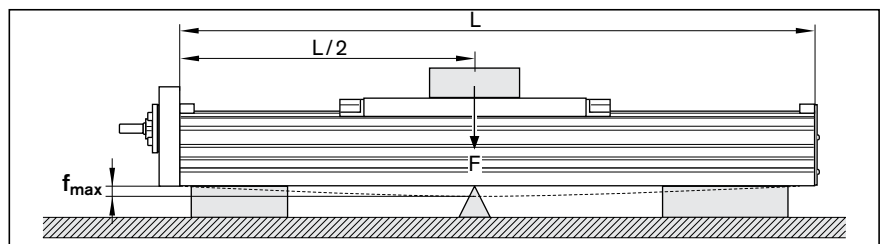

Maximum permissible load

When selecting linear motion systems, it is essential to consider the maximum permissible load and force tolerances. The values depend on the system. In other words, the tolerances are determined not only by the load ratings of the bearing points but also tolerances based on design and material.

Conditions for combined loads:

$$\frac{|F_y|}{F_{y \max}} + \frac{|F_z|}{F_{z \max}} + \frac{|M_x|}{M_{x \max}} + \frac{|M_y|}{M_{y \max}} + \frac{|M_z|}{M_{z \max}} \leq 1$$

Linear guide life

The life of the rolling bearing points contained in a linear motion system can be calculated using the formulas given below. The roller bearings that determine the life of a linear motion system with ball screw assembly are the linear guideway, the ball screw assembly (nut) and the fixed bearing. The linear guideway in the linear motion system must withstand the load as well as any process forces that occur.

⚠ The life of the linear motion system is the separately calculated life that is the shortest (for linear guideway, ball screw assembly or fixed bearing).

Where the operating conditions vary (speed and load), the service life must be calculated using the average values v_{mrs} and F_{mrs} .

Nominal life in meters:

MKK / MKR

MLR

$$L_{gw} = \left(\frac{C_{gw}}{F_{mgw}} \right)^3 \cdot 10^5$$

$$L = \left(\frac{C_y}{F_{comb}} \right)^3 \cdot 10^5$$

Nominal life in hours:

$$L_{hgw} = \frac{L_{gw}}{3600 \cdot v_{mgw}}$$

Dynamic equivalent load on bearing of the guideway:

$$F_{mgw} = \sqrt[3]{|F_{eff1}|^3 \cdot \frac{qt1}{100\%} + |F_{eff2}|^3 \cdot \frac{qt2}{100\%} + |F_{eff3}|^3 \cdot \frac{qt3}{100\%} + |F_{effn}|^3 \cdot \frac{qtn}{100\%}}$$

The following applies to linear motion systems:

$$F_{eff} = F_{comb}$$

Combined equivalent bearing load:

$$F_{comb} = |F_y| + |F_z| + C_{gw} \cdot \frac{|M_x|}{M_t} + C_{gw} \cdot \frac{|M_y|}{M_L} + C_{gw} \cdot \frac{|M_z|}{M_L}$$

- MKK / MKR

- MLR

$$F_{comb} = |F_y| + C_y \cdot \frac{|F_z|}{C_z} + C_y \cdot \frac{|M_x|}{M_t} + C_y \cdot \frac{|M_y|}{M_L} + C_y \cdot \frac{|M_z|}{M_L}$$

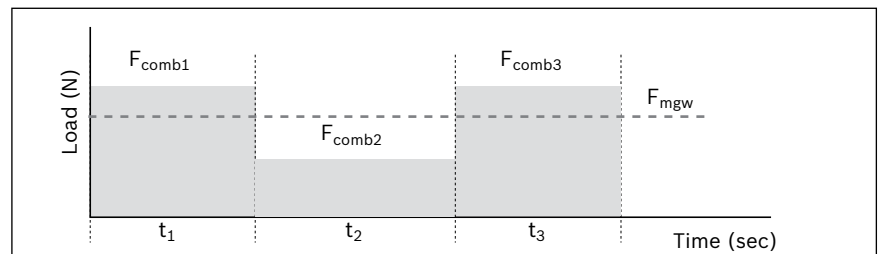

Mean speed of the guide:

$$v_{mgw} = \frac{|v_1| \cdot qt1 + |v_2| \cdot qt2 + \dots + |v_n| \cdot qtn}{100\%}$$

Service life of ball screw assembly or the fixed bearing

Under variable operating conditions (rotary speed and load), the means F_{mbs} and n_m have to be used when calculating life.

Nominal life in revolutions:

$$L_{bs} = \left(\frac{C_{bs}}{F_{mbs}} \right)^3 \cdot 10^6$$

Nominal life in hours:

$$L_{hbs} = \frac{L_{bs}}{60 \cdot n_m}$$

Dynamic equivalent load on bearing of the ball screw assembly:

$$F_{mbs} = \sqrt[3]{|F_{eff1}|^3 \cdot \frac{|n_1|}{n_m} \cdot \frac{q_{t1}}{100\%} + |F_{eff2}|^3 \cdot \frac{|n_2|}{n_m} \cdot \frac{q_{t2}}{100\%} + |F_{eff3}|^3 \cdot \frac{|n_3|}{n_m} \cdot \frac{q_{t3}}{100\%} + \dots + |F_{effn}|^3 \cdot \frac{|n_n|}{n_m} \cdot \frac{q_{tn}}{100\%}}$$

The following applies to the axial load F_n for linear motion systems:

$$F_{eff} = |F_n|$$

When both the load and the rotary speed vary, the average load F_{mbs} is calculated as follows:

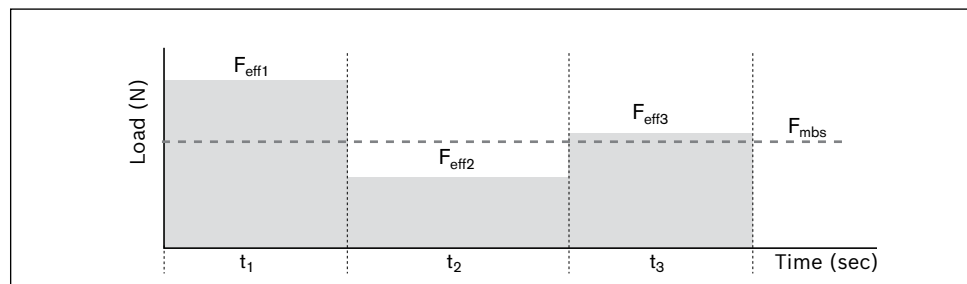

Average rotary speed of the spindle:

$$n_m = \frac{|n_1| \cdot q_{t1} + |n_2| \cdot q_{t2} + \dots + |n_n| \cdot q_{tn}}{100\%} = \frac{v_{mgw} \cdot 60\,000}{SI}$$

If rotary speed varies, average rotary speed n_m is calculated as follows:

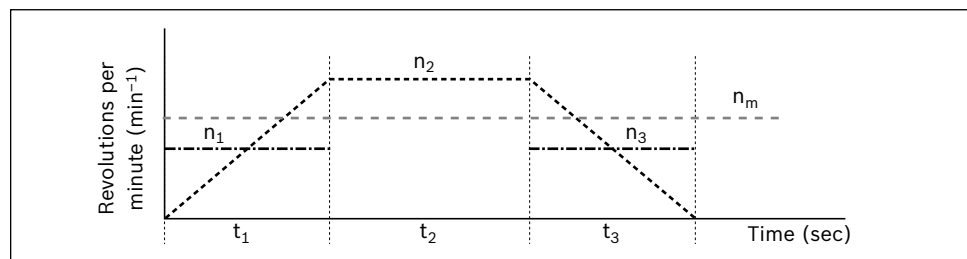

Rotary speed in acceleration and braking phases $n_{1 \dots n}$:

$$n_{1 \dots n} = \frac{n_{A1 \dots n} + n_{E1 \dots n}}{2}$$

Drive dimensioning

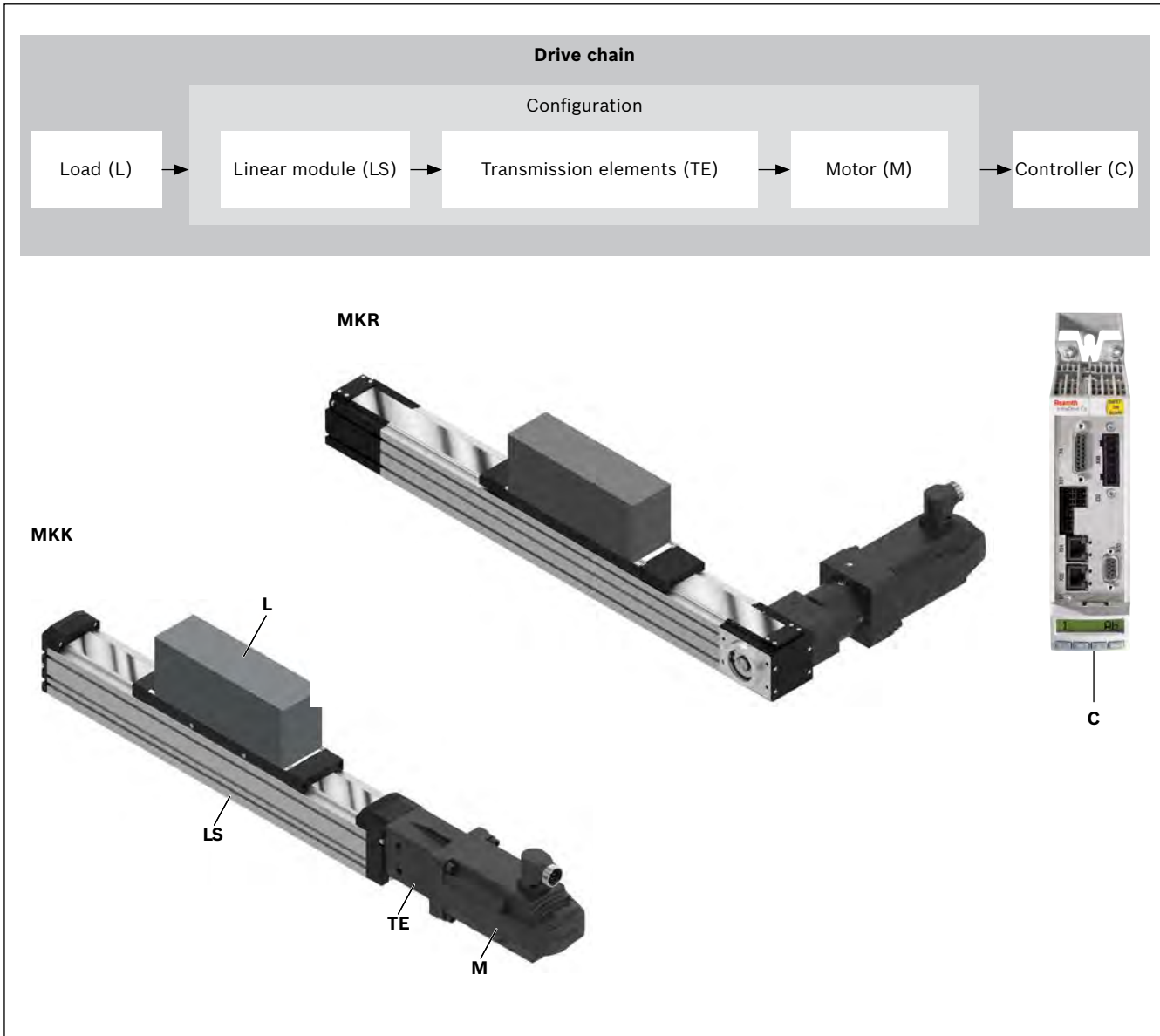

The correct dimensioning and assessment of an application requires structured consideration of the drive chain as a whole.

The basic element of the drive chain is the configuration – made up of the linear motion system, the transmission element (coupling, belt side drive or gear unit) and the motor – which can be ordered in that constellation in the catalog.

Basic principles

For drive dimensioning, the drive chain can be divided into the mechanical system and drive system.

The mechanical system includes the physical components – linear motion system and the transmission elements (timing belt side drive, coupling) – and the load to be carried.

The electric drive is a motor-controller combination with corresponding performance data.

The dimensioning of the electric drive is done taking the motor shaft as a reference point.

For drive dimensioning, limits must be taken into account as well as base values. The limits must not be exceeded in order to avoid damaging the mechanical components.

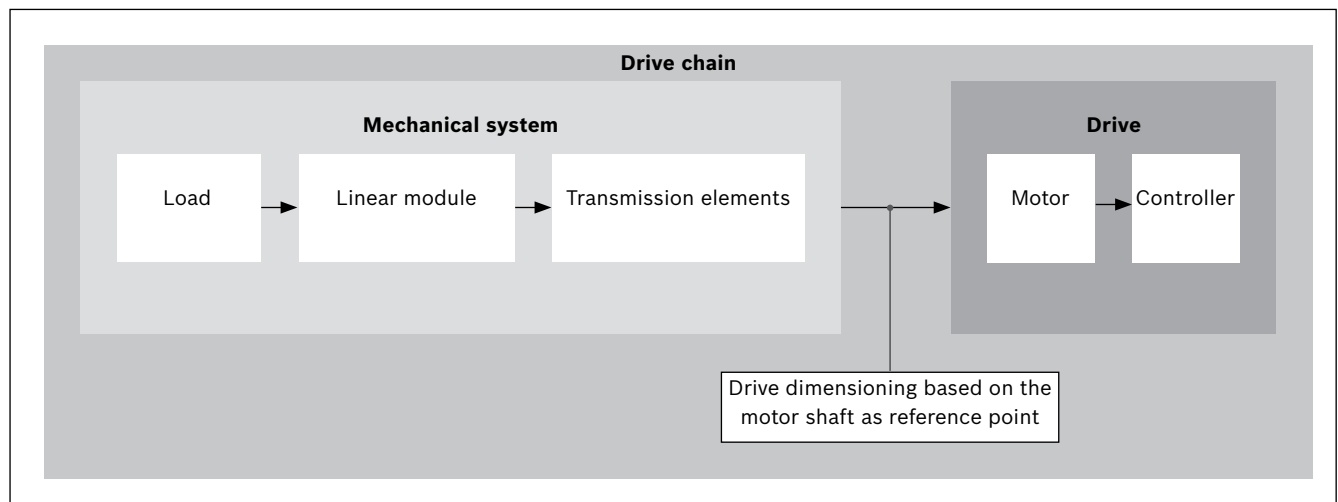

Technical data and formula symbols for the mechanical system

For every component (linear motion system, coupling, belt side drive, gear unit), the corresponding maximum permissible limits for drive torque and speed, and the base values for friction moment and mass moment of inertia have to be used.

The following technical data with the associated formula symbols are used when considering the basic mechanical system requirements in the design calculations for dimensioning the drive. The data listed in the table below can be found in the section titled "Technical Data" or is determined using formulas based on the descriptions on the following pages.

	Mechanical system				
	Load	Linear motion system	Transmission element		
			Coupling	Belt side drive	Gearing
Weight moment (Nm)	$M_g^{6)}$	—	—	—	—
Frictional torque (Nm)	— ⁵⁾	$M_{Rs}^{3)}$	—	$M_{Rsd}^{3)}$	$M_{Rge}^{3)}$
Mass moment of inertia (kgm ²)	$J_t^{1)}$	$J_s^{2)}$	$J_c^{3)}$	$J_{sd}^{3)}$	$J_{ge}^{3)}$
Max. permissible speed (m/s)	—	$v_{max}^{4)}$	—	—	—
Max. permissible rotary speed (min ⁻¹)	—	$n_p^{1)}$			$n_{ge}^{3)}$
Max. permissible drive torque (Nm)	—	$M_p^{4)}$	$M_{cN}^{3)}$	$M_{sd}^{3)}$	$M_{ge}^{3)}$

1) Determine the value using the appropriate formula
 2) Length-dependent value, determined using the appropriate formula
 3) Use the value from the table
 4) Length-dependent value, to be read off the graph
 5) Any additional process forces are to be taken into consideration as load moments
 6) For vertical mounting position: Determine the value using the appropriate formula

Drive dimensioning with motor shaft as reference point

When dimensioning the drive, all relevant design calculation values for the mechanical components in the drive chain have to be determined and be expressed/reduced to the motor shaft. For a combination of mechanical components within the drive chain, this will result in one value for each of the following:

- ▶ Frictional torque M_R
- ▶ Mass moment of inertia J_{ex}
- ▶ Maximum permissible speed v_{mech} (maximum permissible rotary speed n_{mech})
- ▶ Max. permissible drive torque M_{mech}

Determination of the values for each mechanical component in the drive chain based on the motor shaft as a reference point

Linear modules MKK	
Frictional torque M_R	
For motor attachment via flange and coupling	$M_R = M_{Rs}$
For motor attachment via belt side drive	$M_R = M_{Rsd} + \frac{M_{Rs}}{i}$
Mass moment of inertia J_{ex}	
For motor attachment via belt side drive	$J_{ex} = J_{sd} + \frac{(J_s + J_t)}{i^2}$
For motor attachment via flange and coupling	$J_{ex} = J_s + J_t + J_c$

Linear modules MKR	
Frictional torque M_R	
For motor attachment via gear	$M_R = M_{Rge} + \frac{M_{Rs}}{i}$
Mass moment of inertia J_{ex}	
For direct motor attachment (without gear)	$J_{ex} = J_s + J_t$
For motor attachment via gear	$J_{ex} = J_{ge} + \frac{(J_s + J_t)}{i^2}$

Mass moment of inertia of linear motion system

$$J_s = (k_{J \text{ fix}} + k_{J \text{ var}} \cdot L) \cdot 10^{-6}$$

Determination of translative mass moment of inertia of the external load

$$J_t = m_{ex} \cdot k_{Jm} \cdot 10^{-6}$$

Maximum permissible speed v_{mech} or max. permissible rotary speed n_{mech}

The lowest of all the values for maximum permissible speed or rpm of all mechanical components contained in the drive chain determines the maximum permissible speed of the mechanical system which has to be taken into consideration as the upper limit for the drive when sizing the motor.

Depending on the system, the maximum permissible speed/rotary speed of the linear motion system with ball screw assembly is always below the limits for the coupling or belt side drive components, meaning it determines the maximum permissible speed of the mechanical system.

Linear modules MKK	
Maximum permissible speed	$v_{\text{mech}} = v_{\text{max}}$
Maximum permissible rotary speed	
For motor attachment via flange and coupling	$n_{\text{mech}} = \frac{v_{\text{mech}} \cdot 1\,000 \cdot 60}{S}$
For motor attachment via belt side drive	$n_{\text{mech}} = \frac{v_{\text{mech}} \cdot i \cdot 1\,000 \cdot 60}{S}$

Linear modules MKR		
Maximum permissible speed		
For direct motor attachment (without gearing)	$v_{\text{mech}} = v_{\text{max}}$	$v_{\text{mech}} = \frac{n_{\text{mech}} \cdot \pi \cdot d_3}{1000 \cdot 60}$
For motor attachment via gear	$v_{\text{mech}} = \frac{n_{\text{mech}} \cdot \pi \cdot d_3}{i \cdot 1\,000 \cdot 60}$	
Maximum permissible rotary speed		
For direct motor attachment (without gear)	$n_{\text{mech}} = \frac{v_{\text{mech}} \cdot 1\,000 \cdot 60}{\pi \cdot d_3}$	$n_{\text{mech}} = n_p$
For motor attachment via gear	$n_p = \frac{v_{\text{max}} \cdot 1\,000 \cdot 60}{\pi \cdot d_3}$	$n_{\text{mech}} = \text{minimum}(n_p \cdot i ; n_{ge})$

Maximum permissible drive torque M_{mech}

The lowest (minimum) of all the values for permissible drive torque of all mechanical components contained in the drive chain determines the maximum permissible drive torque of the mechanical system which has to be taken into consideration as the upper limit for the drive when sizing the motor.

Linear modules MKK

For motor attachment via flange and coupling

$$M_{\text{mech}} = \text{minimum} (M_{\text{cN}}; M_{\text{p}})$$

For motor attachment via belt side drive

$$M_{\text{mech}} = \text{minimum} (M_{\text{sd}}; \frac{M_{\text{p}}}{i})$$

Linear modules MKR

For direct motor attachment (without gearing)

$$M_{\text{mech}} = M_{\text{p}}$$

For motor attachment via gear

$$M_{\text{mech}} = \text{minimum} (\frac{M_{\text{ge}}}{i}; \frac{M_{\text{p}}}{i})$$

⚠ When considering the complete drive chain (mechanical system + motor/controller), the maximum torque of the motor can lie below the maximum value for the mechanical system (M_{mech}) and thus limit the maximum permissible drive torque of the overall drive chain.

If the maximum torque of the motor lies above the upper limit for the mechanical system (M_{mech}), the maximum motor torque must be limited to the permissible value for the mechanical system.

General motor preselection

The motor can be generally preselected using the following conditions.

Condition 1:

The rotary speed of the motor must be greater than or equal to the rotary speed required for the mechanical system (but not exceeding the maximum permissible limit value).

$$n_{\text{max}} \geq n_{\text{mech}}$$

Condition 2:

Consideration of the ratio of mass moments of inertia of the mechanical system and the motor. The ratio of the mass moments of inertia serves as an indicator for the control performance of a motor-controller combination. The mass moment of inertia of the motor is directly related to the motor size.

Ratio of mass moments of inertia

For preselection, experience has shown that the following ratios will result in high control performance. These are not rigid limits, but values exceeding them will require closer consideration of the specific application.

Application area	V
Handling	≤ 6.0
Processing	≤ 1.5

$$V = \frac{J_{ex}}{J_m + J_{br}}$$

Condition 3:

Estimation of the ratio of the static load moment to the continuous torque of the motor. The torque ratio must be less than or equal to an empirical value of 0.6. This condition roughly factors in the missing dynamic characteristics of an exact motion profile with the required motor torques.

Torque ratio

$$\frac{M_{stat}}{M_0} \leq 0.6$$

Static load moment

$$M_{stat} = M_R + M_g$$

Linear modules MKK

Weight moment
For vertical mounting position only!
 For motor attachment via flange and coupling: $i = 1$

$$M_g = \frac{P \cdot (m_{ex} + m_{ca}) \cdot g}{2\,000 \cdot \pi \cdot i}$$

Linear modules MKR

Weight moment
For vertical mounting position only!

$$M_g = \frac{d_3 \cdot (m_{ex} + m_{ca}) \cdot g}{2\,000 \cdot i}$$

In the section titled ➡ "Configuration and ordering", users can put together standard configurations, including motor attachment, gears and motor, for the various linear motion system sizes by selecting the appropriate options. By checking the above conditions, it is possible to see whether a standard motor selected in a particular configuration will generally be of a suitable size for the specific application.

Precise drive dimensioning

Preselecting the motor according to this rough guide is no substitute for the required precise design calculations for the drive, taking all moments/torques and rotary speed levels into account. For precise calculation of the electric drive, including consideration of the specific motion profile, please refer to the performance data in the catalog "Rexroth drive technology".

When dimensioning the drive, the maximum permissible values for linear speed, drive torque and acceleration must not be exceeded, in order to avoid damaging the mechanical system.

Calculation example MKK with timing belt side drive

Given data

In a handling task, a mass of 30 kg is to be moved horizontally by 500 mm at a travel speed of 0.5 m/s. The following was selected based on the technical data and the installation space:

Linear module MKK-080-NN-3

- With sealing strip
- Motor attachment via belt side drive, $i = 1.5$
- With AC servo motor MS2N04-B0BTN with brake

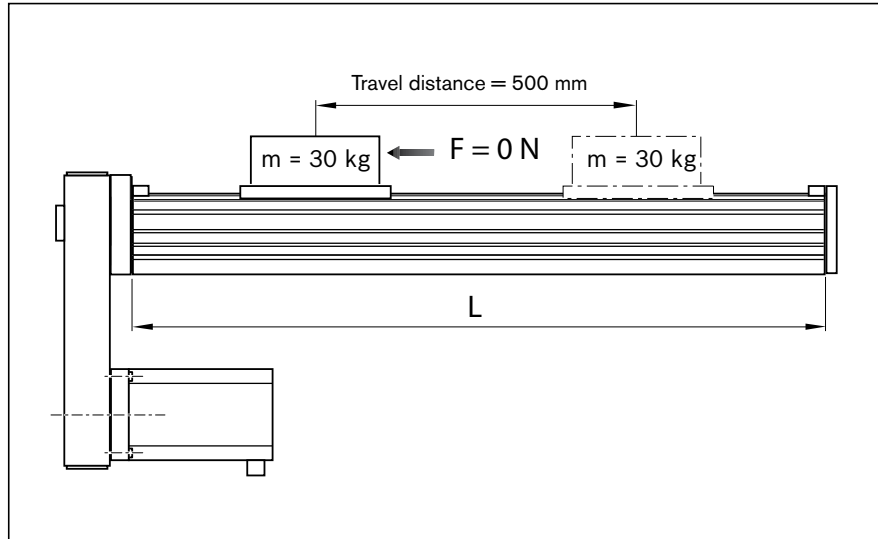

Estimation of length L

(The first estimate assumes a large lead ($P = 20$ mm) and therefore length, since the permissible speed can decrease as length increases. For the excess travel s_e , the value $2 \times P$ is selected).

	$L = s_{\text{eff}} + 2 \cdot s_e + L_{\text{ca}} + L_{\text{ad}}$
Excess travel:	$s_e = 2 \cdot P = 2 \cdot 20 = 40$ mm
Max. travel:	$s_{\text{max}} = s_{\text{eff}} + 2 \cdot s_e$ $= 500 + 2 \cdot 40 = 580$ mm
Length:	$L = 580 + 260 + 109 = 949$ mm

Selection of the ball screw assembly

(Better to choose the lowest lead as this is favorable in terms of resolution, braking distance, length.)

Permissible ball screw assembly according to the "Permissible speed" graph at $v = 0.5$ m/s and $L = 949$ mm:

Ball screw assembly 20 x 10 and ball screw assembly 20 x 20

Selected ball screw assembly (lower lead):

Ball screw assembly 20 x 10

Maximum permissible speed for ball screw assembly 20 x 10 as read off from graph:

$v_{\text{max}} = 0.63$ m/s

Calculation of length L

(For selected ball screw assembly)

Excess travel:	$s_e = 2 \cdot P = 2 \cdot 10 = 20$ mm
Max. travel:	$s_{\text{max}} = s_{\text{eff}} + 2 \cdot s_e$ $= 500 + 2 \cdot 20 = 540$ mm
Length:	$L = 540 + 260 + 109 = 909$ mm

Frictional torque M_R

(Motor attachment via belt side drive)

	$M_R = M_{\text{Rsd}} + \frac{M_{\text{Rs}}}{i}$
Linear module:	$M_{\text{Rs}} = 0.50$ Nm
Belt side drive:	$M_{\text{Rsd}} = 0.40$ Nm ($i = 1.5$)
Frictional torque:	$M_R = 0.40 + \frac{0.50}{1.5} = 0.73$ Nm

Mass moment of inertia J_{ex}
(Motor attachment via belt side drive)

$$J_{ex} = J_{sd} + \frac{(J_s + J_t)}{i^2}$$

Belt side drive: $J_{sd} = 85 \cdot 10^{-6} \text{ kgm}^2$

Linear module: $J_s = (k_{J_{fix}} + k_{J_{var}} \cdot L) \cdot 10^{-6} = (16.628 + 0.084 \cdot 909) \cdot 10^{-6}$
 $= 92.984 \cdot 10^{-6} \text{ kgm}^2$

External load: $J_t = m_{ex} \cdot k_{J_m} \cdot 10^{-6} = 30 \cdot 2.533 \cdot 10^{-6} = 75.99 \cdot 10^{-6} \text{ kgm}^2$

Mass moment of inertia: $J_{ex} = 85 \cdot 10^{-6} + \frac{(92.984 \cdot 10^{-6} + 75.99 \cdot 10^{-6})}{1.5^2}$
 $= 160.1 \cdot 10^{-6} \text{ kgm}^2$

Maximum permissible rotary speed n_{mech}
(Motor attachment via belt side drive)
Limit for mechanical system

$$n_{mech} = \frac{(v_{mech} \cdot i \cdot 1,000 \cdot 60)}{SI}$$

Max. permissible speed: $v_{mech} = v_{max} = 0.63 \text{ m/s}$

Max. permissible rotary speed: $n_{mech} = \frac{(0.63 \cdot 1.5 \cdot 1\,000 \cdot 60)}{10} = 5,670 \text{ min}^{-1}$

Maximum rotary speed of application n_{mech}
(Motor attachment via belt side drive)
Application tolerance

Travel speed: $v_{mech} = 0.5 \text{ m/s}$

Rotary speed: $n_{mech} = \frac{0.5 \cdot 1.5 \cdot 1\,000 \cdot 60}{10} = 4,500 \text{ min}^{-1}$

Maximum permissible drive torque M_{mech}
(Motor attachment via belt side drive)
Limit for mechanical system

$$M_{mech} = \text{Minimum} (M_{sd}; \frac{M_p}{i})$$

Belt side drive: $M_{sd} = 5.0 \text{ Nm}$ (gear ratio $i = 1.5$ for MS2N-04)

Linear module: $M_p = 9.8 \text{ Nm}$

Drive torque: $M_{mech} = \text{Minimum} (5.0; \frac{9.8}{1.5})$
 $= \text{Minimum} (5.0; 6.53) = 5.0 \text{ Nm}$

Calculation example MKK with timing belt side drive (continued)

Motor preselection check

Selected motor:
MS2N04-B0BTN with brake

Condition 1:

$$\begin{aligned} \text{Rotary speed: } n_{\max} &\geq n_{\text{mech}} \\ 6\,000 &\geq 4,500 \text{ condition met – motor selection OK} \end{aligned}$$

Condition 2:

$$\begin{aligned} \text{Mass moment of inertia ratio: } V &= \frac{J_{\text{ex}}}{J_{\text{m}} + J_{\text{br}}} \\ \text{Motor inertia: } J_{\text{m}} &= 70.0 \cdot 10^{-6} \text{ kgm}^2 \\ \text{Brake moment of inertia: } J_{\text{br}} &= 40 \cdot 10^{-6} \text{ kgm}^2 \\ \text{Moment of inertia ratio: } V &= \frac{160.1 \cdot 10^{-6}}{(70 \cdot 10^{-6} + 40 \cdot 10^{-6})} \\ &= 1.46 \\ \text{Handling condition: } V &\leq 6 \\ 1.46 &\leq 6 \text{ condition met – motor selection OK} \end{aligned}$$

Condition 3:

$$\begin{aligned} \text{Torque ratio: } \frac{M_{\text{stat}}}{M_0} &\leq 0.6 \\ \text{Static load moment: } M_{\text{stat}} &= M_{\text{R}} + M_{\text{g}} \text{ (installed horizontally } M_{\text{g}} = 0) \\ &= 0.73 \text{ Nm} \\ \text{Continuous motor torque: } M_0 &= 1.75 \text{ Nm} \\ \text{Torque ratio: } \frac{0.73}{1.75} &= 0.42 \\ 0.42 &\leq 0.6 \text{ condition met – motor selection OK} \end{aligned}$$

All three conditions met \Rightarrow selected motor is suitable for the application.

Result

Linear module MKK-080-NN-3

$L = 909 \text{ mm}$, $s_{\max} = 540 \text{ mm}$, $L_{\text{ca}} = 260 \text{ mm}$; Rexroth ball screw assembly: $d_0 = 20 \text{ mm}$, $P = 10 \text{ mm}$; with corrosion resistant sealing strip; gear ratio $i = 1.5$

Motor preselection: MS2N04-B0BTN with brake

For precise dimensioning of the electric drive, the motor-controller combination must always be considered, as the performance data (e.g. max. useful speed and max. torque) will depend on the controller used.

When doing this, the following data must be considered:

$$\begin{aligned} \text{Frictional torque: } M_{\text{R}} &= 0.73 \text{ Nm} \\ \text{Mass moment of inertia: } J_{\text{ex}} &= 160.1 \cdot 10^{-6} \text{ kgm}^2 \\ \text{Travel speed: } v_{\text{mech}} &= 0.5 \text{ m/s } (n_{\text{mech}} = 4,500 \text{ min}^{-1}) \\ \text{Drive torque limit: } M_{\text{mech}} &= 5.0 \text{ Nm} \\ \Rightarrow \text{ The motor torque must be limited to } 5.0 \text{ Nm on the drive side!} \\ \text{Acceleration limit: } a_{\max} &= 50 \text{ m/s}^2 \\ \text{Limit for travel speed: } v_{\max} &= 0.63 \text{ m/s } (n_{\text{mech}} = 5,670 \text{ min}^{-1}) \end{aligned}$$

Besides the preferred type MS2N04-B0BTN, other motors with identical connection dimensions can be adapted while taking care not to exceed the calculated limit values.

Calculation example MKR with gear reducer

Given data

In a handling task, a mass of 25 kg is to be moved horizontally by 1800 mm at a travel speed of 1.5 m/s. The following was selected based on the technical data and the installation space:

Linear module MKR-080-NN-3

- Carriage length = 260 mm
- Motor attachment via gear reducer, $i = 5$
- Max. permissible linear speed = 3 m/s ($i = 5$)
- With AC servo motor MS2N05-C0BTN with brake

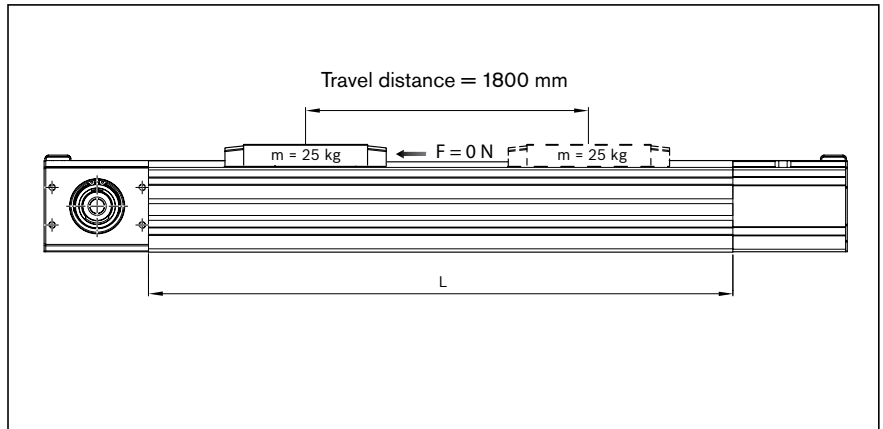

Calculation of length L

(In most cases, the recommended limit for excess travel is 2x feed constant. The excess travel must be greater than the emergency stop stopping distance, which is calculated for exact dimensioning of the electrical drive.)

	$L = s_{\max} + L_{ca} + L_{ad}$
Feed constant:	$u = \frac{u(i=1)}{i}$
	$= \frac{205}{5} = 41 \text{ mm}$
Excess travel:	$s_e = 2 \cdot u = 2 \cdot 41 = 82 \text{ mm}$
Max. travel:	$s_{\max} = s_{\text{eff}} + 2 \cdot s_e$
	$= 1,800 + 2 \cdot 82 = 1,964 \text{ mm}$
Length:	$L = 1,964 + 260 + 17 = 2,241 \text{ mm}$

Frictional torque M_R

	$M_R = M_{Rge} + \frac{M_{Rs}}{i}$
Linear module:	$M_{Rs} = 2.0 \text{ Nm}$
Gear:	$M_{Rge} = 0.5 \text{ Nm}$
Frictional torque:	$M_R = 0.5 + \frac{2.0}{5} = 0.9 \text{ Nm}$

Mass moment of inertia J_{ex}

	$J_{ex} = J_{ge} + \frac{(J_s + J_t)}{i^2}$
Linear module:	$J_s = (k_{J \text{ fix}} + k_{J \text{ var}} \cdot L) \cdot 10^{-6}$
	$= (3,197 + 0.3188 \cdot 2,241) \cdot 10^{-6}$
	$= 3,911.43 \cdot 10^{-6} \text{ kgm}^2$
External load:	$J_t = m_{ex} \cdot k_{Jm} \cdot 10^{-6}$
	$= 25 \cdot 1065 \cdot 10^{-6}$
	$= 26,625 \cdot 10^{-6} \text{ kgm}^2$
Mass moment of inertia:	$J_{ex} = 129 \cdot 10^{-6} + \frac{(3,911.43 \cdot 10^{-6} + 26,625 \cdot 10^{-6})}{5^2}$
	$= 1,350.457 \cdot 10^{-6} \text{ kgm}^2$

Calculation example MKR with gear reducer (continued)

Maximum permissible rotary speed n_{mech}

(Motor attachment via gear reducer, without considering the motor)

Limit for mechanical system

$$\begin{aligned}
 n_{\text{mech}} &= \text{Minimum} (n_p \cdot i ; n_{\text{ge}}) \\
 \text{Linear module: } n_p &= \frac{v_{\text{max}} \cdot 1,000 \cdot 60}{\pi \cdot d_3} \\
 &= \frac{3 \cdot 1\,000 \cdot 60}{\pi \cdot 65,27} \\
 &= 878 \text{ min}^{-1} \\
 \text{Gear: } n_{\text{ge}} &= 7,000 \text{ min}^{-1} \\
 \text{Max. permissible rotary speed: } n_{\text{mech}} &= \text{Minimum} (878 \cdot 5 ; 7,000) \\
 &= \text{Minimum} (4,390 ; 7,000) \\
 &= 4,390 \text{ min}^{-1}
 \end{aligned}$$

Maximum permissible speed v_{mech}

(Motor attachment via gear reducer, without considering the motor)

Limit for mechanical system

$$\begin{aligned}
 v_{\text{mech}} &= \frac{n_{\text{mech}} \cdot \pi \cdot d_3}{i \cdot 1000 \cdot 60} \\
 \text{Max. permissible speed: } v_{\text{mech}} &= \frac{4,390 \cdot \pi \cdot 65,27}{5 \cdot 1\,000 \cdot 60} \\
 &= 3.0 \text{ m/s}
 \end{aligned}$$

Maximum permissible rotary speed of the application n_{mech}

(Motor attachment via gear reducer, without considering the motor)

Application tolerance

$$\begin{aligned}
 \text{Travel speed: } v_{\text{mech}} &= 1.5 \text{ m/s} \\
 \text{Rotary speed: } n_{\text{mech}} &= \frac{v_{\text{mech}} \cdot i \cdot 1\,000 \cdot 60}{\pi \cdot d_3} \\
 &= \frac{1.5 \cdot 5 \cdot 1\,000 \cdot 60}{\pi \cdot 65,27} \\
 &= 2,194 \text{ min}^{-1}
 \end{aligned}$$

Maximum permissible drive torque M_{mech}

(Motor attachment via gear reducer, without considering the motor)

Limit for mechanical system

$$\begin{aligned}
 M_{\text{mech}} &= \text{Minimum} \left(\frac{M_{\text{ge}}}{i} ; \frac{M_p}{i} \right) \\
 \text{Linear module: } M_p &= 36 \text{ Nm} \\
 \text{Gear: } M_{\text{ge}} &= 176 \text{ Nm} \\
 \text{Drive torque: } M_{\text{mech}} &= \text{Minimum} \left(\frac{176}{5} ; \frac{36}{5} \right) \\
 &= \text{Minimum} (35.2 ; 7.2) \\
 &= 7.2 \text{ Nm}
 \end{aligned}$$

Motor preselection check

Selected motor:
MS2N05-C0BTN with brake

Condition 1:

$$\begin{aligned} \text{Rotary speed: } n_{\max} &\geq n_{\text{mech}} \\ 6\,000 &\geq 2,194 \text{ condition met – motor selection OK} \end{aligned}$$

Condition 2:

$$\begin{aligned} \text{Mass moment of inertia ratio: } V &= \frac{J_{\text{ex}}}{J_{\text{m}} + J_{\text{br}}} \\ \text{Motor inertia: } J_{\text{m}} &= 290 \cdot 10^{-6} \text{ kgm}^2 \\ \text{Brake moment of inertia: } J_{\text{br}} &= 110 \cdot 10^{-6} \text{ kgm}^2 \\ \text{Moment of inertia ratio: } V &= \frac{1350.457 \cdot 10^{-6}}{400 \cdot 10^{-6}} \\ &= 3.38 \\ \text{Handling condition: } V &\leq 6 \\ 3.38 &\leq 6 \text{ condition met – motor selection OK} \end{aligned}$$

Condition 3:

$$\begin{aligned} \text{Torque ratio: } \frac{M_{\text{stat}}}{M_0} &\leq 0.6 \\ \text{Static load moment: } M_{\text{stat}} &= M_{\text{R}} + M_{\text{g}} \text{ (installed horizontally } M_{\text{g}} = 0) \\ &= 0.9 \text{ Nm} \\ \text{Continuous torque of the motor: } M_0 &= 6.1 \text{ Nm} \\ \text{Torque ratio: } \frac{0.9}{6.1} &= 0.15 \\ 0.15 &\leq 0.6 \text{ condition met – motor selection OK} \end{aligned}$$

All three conditions met \Rightarrow selected motor is suitable for the application.

Result**Linear module MKR-080-NN-3**

$L = 2,241 \text{ mm}$, $s_{\max} = 1,964 \text{ mm}$, $L_{\text{ca}} = 260 \text{ mm}$, belt drive, motor attachment via planetary gearbox, gear ratio $i = 5$

Motor preselection: MS2N05-C0BTN with brake

For precise dimensioning of the electric drive, the motor-controller combination must always be considered, as the performance data (for example, maximum useful speed and maximum torque) will depend on the controller used.

When doing this, the following data must be considered.

Frictional torque	$M_{\text{R}} = 0.9 \text{ Nm}$
Mass moment of inertia	$J_{\text{ex}} = 1,350.457 \cdot 10^{-6} \text{ kgm}^2$
Travel speed	$v_{\text{mech}} = 1.5 \text{ m/s}$ ($n_{\text{mech}} = 2,194 \text{ min}^{-1}$)
Drive torque limit	$M_{\text{mech}} = 7.2 \text{ Nm}$
\Rightarrow The motor torque must be limited to 7.2 Nm on the drive side!	
Acceleration limit	$a_{\max} = 50 \text{ m/s}^2$
Limit for travel speed	$v_{\max} = 3.0 \text{ m/s}$ ($n_{\text{mech}} = 4,390 \text{ min}^{-1}$)

After determining the emergency-stop braking path during precise dimensioning, the selected excess travel must be checked to see whether it is sufficient and adjusted if necessary.

Besides the preferred type MS2N05-C0BTN, other motors with identical connection dimension can be adapted while taking care not to exceed the calculated limits.

Abbreviations

Abbreviations

Abbreviation/ Index	Name	Unit
a	Acceleration	(m/s ²)
a_{max}	Maximum acceleration rate	(m/s ²)
Rexroth ball screw assembly	Ball screw assembly	(–)
B_t	Belt type	(–)
c_{spe}	Specific spring rate	(N)
C_{gw}	Dynamic load capacity, guideway	(N)
C_{bs}	Dynamic load capacity for ball screw assembly	(N)
C_{fb}	Dynamic load capacity for fixed bearing	(N)
d₀	Nominal diameter of ball screw assembly	(mm)
d₃	Belt pulley diameter	(mm)
f_w	Load factor	(–)
F_n	Axial load of the ball screw assembly	(N)
F_{eff}	Effective equivalent axial load	(N)
F_{bp}	Max. belt drive transmission force	(N)
F_{comb}	Combined equivalent bearing load	(N)
F_{mbs}	Dynamic equivalent load on bearing of the ball screw assembly	(N)
F_{mgw}	Dynamic equivalent load on bearing of the guideway	(N)
F_n	Axial load of the ball screw assembly	(N)
F_{t perm}	Belt elasticity limit	(N)
F_y	Load due to a resulting force in the y-direction	(N)
F_{y max}	Maximum dynamic load in y-direction	(N)
F_z	Load due to a resulting force in the z-direction	(N)
F_{z max}	Maximum dynamic load in z-direction	(N)
g	Gravitational acceleration (= 9.81)	(m/s ²)
i	Gear ratio	(–)
I_y	Planar moment of inertia about the y-axis	(cm ⁴)
I_z	Planar moment of inertia about the z-axis	(cm ⁴)
J_{br}	Mass moment of inertia of the motor brake	(kgm ²)
J_c	Mass moment of inertia of coupling	(kgm ²)
J_{dc}	Mass moment of inertia of drive chain	(kgm ²)
J_{ex}	Mass moment of inertia of the mechanical system	(kgm ²)
J_{ge}	Mass moment of inertia of gear about the motor journal	(kgm ²)
J_m	Mass moment of inertia of motor	(kgm ²)
J_s	Mass moment of inertia of linear motion system	(kgm ²)
J_{sd}	Mass moment of inertia of belt side drive about the motor journal	(kgm ²)
J_t	Translative mass moment of inertia of external load based on the linear motion system screw journal	(kgm ²)

Abbreviation/ Index	Name	Unit
k_{g fix}	Constant for fixed portion of mass	(kg)
k_{g var}	Constant for variable-length portion of mass	(kg/mm)
k_{J fix}	Constant for fixed portion of mass moment of inertia	(kgmm ²)
k_{J m}	Constant for mass-specific portion of mass moment of inertia	(mm ²)
k_{J var}	Constant for variable-length portion of mass moment of inertia	(kgmm)
L	Length of the linear motion system	(mm)
L_{ad}	Additional length	(mm)
L_c	Length nut/length nut and housing	(mm)
L_{ca}	Carriage length	(mm)
L_{bs}	Nominal life (Ball screw assembly, fixed bearing)	(min ⁻¹)
L_{hbs}	Nominal life (Ball screw assembly, fixed bearing)	(h)
L_{gw}	Nominal life of the guideway	(m)
L_{hgw}	Nominal life of the guideway	(h)
L_w	Center-to-center distance between carriages	(mm)
m_{br}	Holding brake mass	(kg)
m_{ca}	Moved mass of system of carriage	(kg)
m_{ex}	Moved external load	(kg)
m_{fc}	Mass of flange and coupling	(kg)
m_m	Mass of the motor	(kg)
m_s	Mass of the linear system (without attachments)	(kg)
m_{sd}	Mass of the timing belt side drive	(kg)
M₀	Continuous motor torque	(Nm)
M_{cN}	Nominal coupling torque	(Nm)
M_g	Weight moment at motor journal	(Nm)
M_{ge}	Maximum permissible acceleration torque of the gear (on the output drive)	(Nm)
M_L	Dynamic longitudinal moment load capacity	(Nm)
M_m	Equivalent dynamic torque	(Nm)
M_{max}	Max. possible motor torque	(Nm)
M_{mech}	Maximum permissible drive torque for mechanical system	(Nm)
M_p	Maximum permissible drive torque (at drive journal)	(Nm)
M_R	Frictional torque at motor journal	(Nm)
M_{Rge}	Frictional torque of gear at motor journal	(Nm)
M_{Rs}	Frictional torque of system	(Nm)
M_{Rsd}	Friction moment of belt side drive at motor journal	(Nm)
M_{sd}	Maximum permissible drive torque of the belt side drive	(Nm)
M_{stat}	Static load moment	(Nm)

Abbreviation/ Index	Name	Unit
M_t	Dynamic torsional moment load capacity	(Nm)
M_x	Dynamic torsional moment around the x-axis	(Nm)
$M_{x \max}$	Maximum permissible torsional moment around the x-axis	(Nm)
M_y	Dynamic torsional moment around the y-axis	(Nm)
$M_{y \max}$	Maximum permissible torsional moment around the y-axis	(Nm)
M_z	Dynamic torsional moment around the z-axis	(Nm)
$M_{z \max}$	Maximum permissible torsional moment around the z-axis	(Nm)
n	Rotary speed of the ball screw assembly	(min^{-1})
n_1, n_2, \dots, n_n	Rotary speed in acceleration and braking phases	(min^{-1})
$n_{A1} \dots n$	Starting speed in Phase 1–n	(min^{-1})
$n_{E1} \dots n$	Ending speed in Phase 1–n	(min^{-1})
n_{ge}	Maximum permissible rotary speed of the gear	(min^{-1})
n_m	Average rotary speed of the ball screw assembly	(min^{-1})
n_{mech}	Maximum permissible rotary speed for mechanical system	(min^{-1})
n_{\max}	Max. motor speed	(min^{-1})
n_p	Maximum permissible rotary speed of the linear motion system	(min^{-1})
SI	Screw lead/ball screw assembly	(mm)
P_{app}	Effective power in application	(W)
Keyway	Keyway	(–)
$q_{t1..n}$	Time step of the phases	(%)
s_a	Acceleration travel	(mm)
s_e	Excess travel	(mm)
s_{eff}	Effective stroke	(mm)
s_{\min}	Min. travel range	(mm)
s_{\max}	Maximum travel	(mm)
SPU	Screw support	(–)
TT	Carriage	(–)
t_a	Acceleration time, braking time	(s)
t_1, t_2, \dots, t_n	Time for phases 1 ... n	(s)
t_{total}	Sum of time steps	(s)
u	Feed constant	(mm/rev)
v_1, v_2, \dots, v_n	Speed in phase 1 ... n	(m/s)
v_{\max}	Maximum permissible speed	(m/s)
v_{mech}	Maximum permissible linear speed of mechanical system	(m/s)
v_{mgw}	Mean speed of the guideway	(m/s)

Abbreviation/ Index	Name	Unit
V	Ratio of mass moments of inertia of drive chain and motor	(–)
z_1	Application point of the effective force	(mm)
π	Pi	(–)

Ordering example MKK-080-NN-3

Ordering example MKK-080-NN-3

Ordering data		Description
Linear module	MKK-080-NN-3	Linear module MKK-080-NN-3
Travel range max. (s_{\max})	2800	–
Material pairing	ALST	Aluminum/steel strip
Lubrication	LSS	Lubrication version LSS
Length measuring system	000	Without length measuring system
Carriage		
Carriage fastening	T	Carriage with thread
Number of carriages	1	One carriage
Carriage center-to-center distance L_w ¹⁾	–	–
Guideway	004	Ball guide rail / frame with center holes
Drive		
Keyway	0	Without keyway
BASA (Rexroth ball screw assembly do x P)	20x10	Nominal diameter = 20 mm, lead = 10 mm
Accuracy class	T7	T7 = lead deviation 53µm/300mm
Screw support	002	2 Screw support (SPU)
Version	F001	With flange and coupling
Mounting interface		
Gear ratio	i = 1	Gear ratio i = 1
Mechanical interface	MS2N04	Motor attachment for servo motor MS2N04
Motor		
Motor code	MS2N04-D0BQN	Motor type
Motor connection	1	Motor connection (1 cable)
Motor holding brake	Y	With holding brake
Motor connector position	180	Motor connector position = 180°
Cover		
Cover version	2	With cover (corrosion resistant steel strip)
Cover with side sealing	0	Without side sealing
Sensor system (available with max. 6 switches)		
Sensor 1	120	PNP NC
2nd sensor	120	PNP NC
Documentation	001	Standard report

¹⁾ Only required for two carriages

Inquiry/order form MKK-xxx-NN-3

Inquiry/order form MKK-xxx-NN-3

Ordering data		Description
Linear module		
Travel range max. (s_{max})		
Material pairing		
Lubrication		
Length measuring system		
Carriage		
Carriage fastening		
Number of carriages		
Carriage center-to-center distance $L_w^{1)}$		
Guideway		
Drive		
Keyway		
BASA (Rexroth ball screw assembly do x P)		
Accuracy class		
Screw support		
Version		
Mounting interface²⁾		
Gear ratio		
Mechanical interface		
Motor		
Motor code		
Motor connection		
Motor holding brake		
Motor connector position		
Cover		
Cover version		
Cover with side sealing		
Sensor system (available with max. 6 switches)		
Sensor 1		
2nd sensor		
Documentation		

¹⁾ Only required for two carriages

²⁾ The motor geometry code is required for motors according to customer specifications

Motor attachment kits according to customer specification (motor geometry code)

The dimensions queried result in a unique "motor geometry code":



Quantity Acceptance of: _____ pcs, _____ per month, _____ per year, per order, or _____
Comments: _____

From

Company: _____
 Address: _____

Name: _____
 Department: _____
 Phone: _____
 Telefax: _____

Further information

Further information

[Bosch Rexroth homepage:](#)

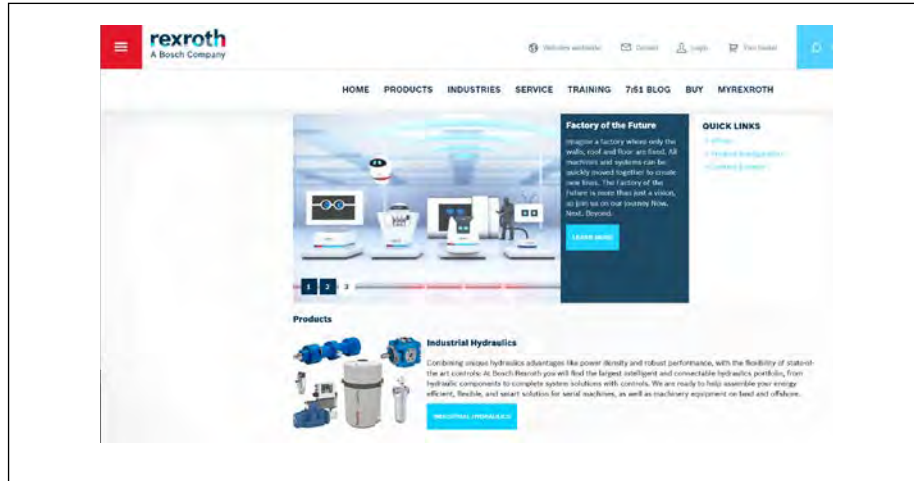

[Product information on Linear Modules:](#)

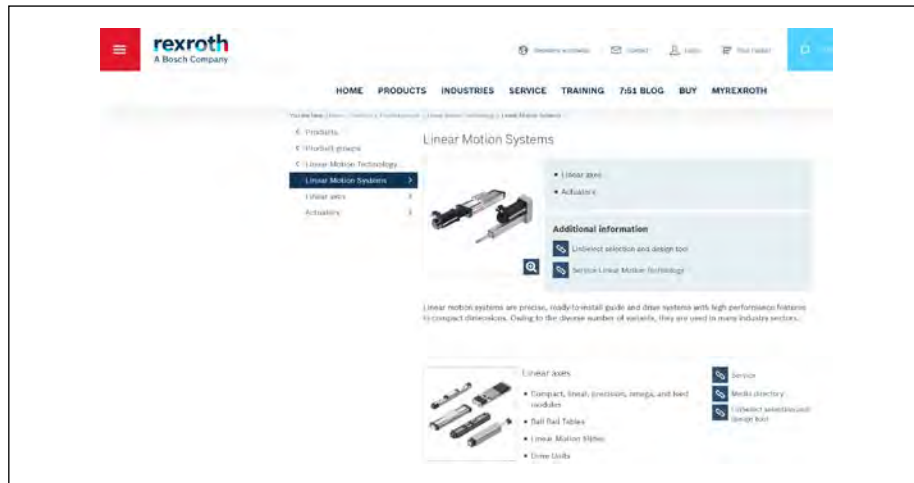

[Configurators and tools:](#)



Notes

Bosch Rexroth Corporation

Corporate Headquarters
14001 South Lakes Drive
Charlotte, NC 28273
Telephone (800) REXROTH
(800) 739-7684
info@boschrexroth-us.com
www.boschrexroth-us.com

Find your local contact person here:

www.boschrexroth-us.com/contactus

E Engineering
Partner

S Systems
Integrator

V Value-Added
Distributor

248-373-1600 • morrell-group.com • orders@morrellinc.com

MI • IN • IL • OH • ON, CAN

MorrellGroup 
Evolution in Controls