

Precision Modules PSK

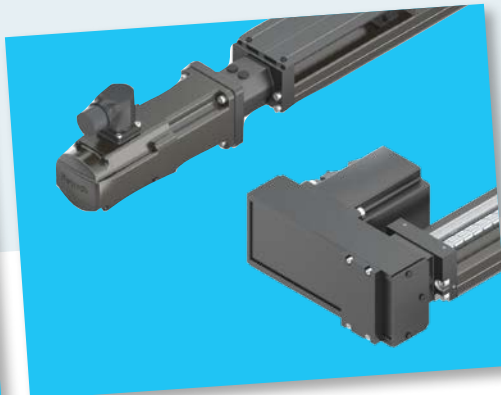
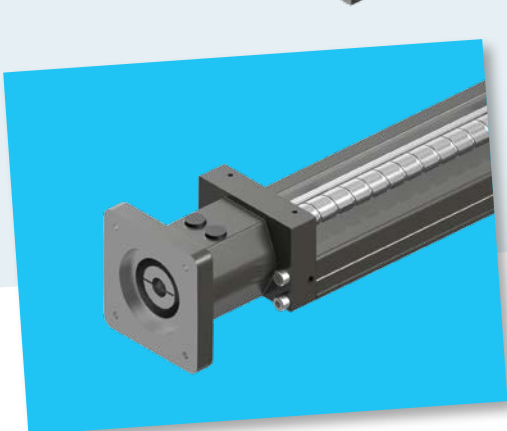
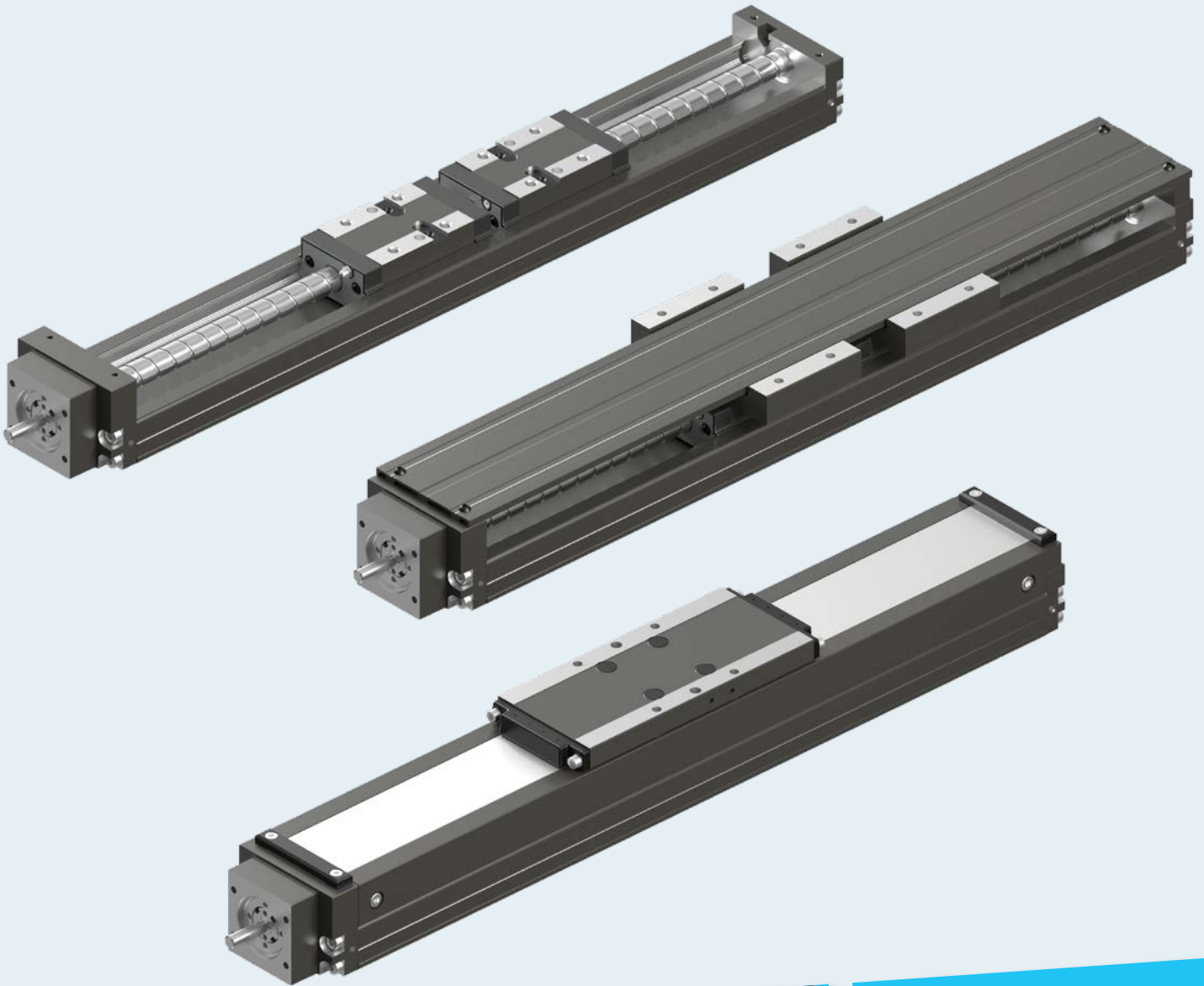

IDENTIFICATION SYSTEM FOR SHORT PRODUCT NAMES

Short product name	Example:	PSK	-	050	-	NN	-	2
System	=	P recision Module						
Guideway	=	Integrated Ball Rail S ys-tem						
Drive unit	=	Ball Screw Assembly (K)						
Size	=	050 / 060 / 090						
Version	=	N ormal version						
Generation	=	Product generation 2						

CHANGES/ADDITIONS AT A GLANCE

<p>Catalog layout</p> <ul style="list-style-type: none"> - Chapter “Form of Delivery” added - Chapter “Calculations” expanded - New layout for “Configuration and Ordering” - New dimensional drawings - Revised layout for technical and drive data tables 	<p>Technical modifications</p> <ul style="list-style-type: none"> - PSK 040 Gen. 2 discontinued - Two accuracy classes - Four lubrication versions - Modified technical data - New Rexroth Ball Screw Assembly for PSK-050 - Smooth frame (side fastening discontinued) - Chapter “Switching System” - Motors: MSK discontinued, integration of MS2N motors 													
<h3>PRODUCT AVAILABILITY</h3> <table border="1"> <thead> <tr> <th>Precision Modules</th> <th>Size</th> <th>Accuracy class</th> <th>North America</th> <th>Worldwide</th> </tr> </thead> <tbody> <tr> <td rowspan="2">PSK-xxx-NN-2</td> <td rowspan="2">-050 / -060 / -090</td> <td>P</td> <td>January 2021</td> <td>June 2021</td> </tr> <tr> <td>N</td> <td>July 2021</td> <td>September 2021</td> </tr> </tbody> </table>		Precision Modules	Size	Accuracy class	North America	Worldwide	PSK-xxx-NN-2	-050 / -060 / -090	P	January 2021	June 2021	N	July 2021	September 2021
Precision Modules	Size	Accuracy class	North America	Worldwide										
PSK-xxx-NN-2	-050 / -060 / -090	P	January 2021	June 2021										
		N	July 2021	September 2021										

Product Description	4
Load capacities and sizes	8
Structural Design	10
Technical Data	14
Technical Data	14
Speed Graphs	20
Drive Torque Graphs	20
Accuracy Graphs	22
Calculations	24
Calculation Principles	24
Drive Dimensioning	27
Calculation Example	31
Configuration and Ordering	35
PSK-050-NN-2	35
PSK-060-NN-2	37
PSK-090-NN-2	39
Dimensional Drawings	40
PSK without Cover	40
PSK with Cover Plate	41
PSK with Sealing Strip (under preparation)	42
Motor attachment with mount and Coupling	44
Motor Attachment with Timing Belt Side Drive	45
Attachments and Accessories	46
Motor attachment kits according to customer specifications	46
IndraDyn S Synchronous Motor MSM	48
IndraDyn S Synchronous Motor MS2N	50
Switch Mounting Arrangements	52
Sensors	54
Extensions	56
Male Connector	58
Passive Distributor	60
Example Combinations	64
Service and Information	66
Operating Conditions	66
Parameterization (Start-up)	67
Mounting	68
Lubrication and Maintenance	69
Documentation	72
Ordering Example for PSK-090	74
Inquiry/Order Form	75
Further Information	76
Abbreviations	78

PRODUCT DESCRIPTION

Rexroth Precision Modules are precise, ready-to-install linear motion systems that combine high performance with compact dimensions. Rexroth offers favorable price/performance ratios and fast delivery.

Structural Design

- ▶ Three sizes: PSK-050, PSK-060, PSK-090
- ▶ Smooth, compact and rigid precision steel profile with integrated Rexroth guideway geometry and machined reference edge
- ▶ Rexroth Ball Screw Assembly with low-friction seal
- ▶ One or two steel carriages, in Standard or long versions
- ▶ Carriage with threads and pin holes
- ▶ Internal elements protected by optional cover

Outstanding features

- ▶ Extremely stiff and highly precise miniature Linear Motion System
- ▶ Machined reference edge on frame facilitates rapid mounting and easy aligning
- ▶ Flexible usage options thanks to two accuracy classes:
 - N = normal class
 - P = precision class
- ▶ Four different lubrication versions:
 - Standard lubrication (LSS)
 - Preserved (LPG)
 - Prepared for connection to central liquid grease lubrication systems (LCF)
 - Lubrication with internationally available standard grease with clean room class > 1000 as per US Fed. Std. 209 (LSC)
- ▶ Double-sealed Rexroth Ball Screw Assembly (low-friction seal)

Attachments

- ▶ Motor attachments via mount and coupling or timing belt side drive
- ▶ Motor attachment kits according to customer specification
- ▶ Maintenance-free servo motors with optional brake and attached feedback
- ▶ Adjustable sensors over the entire travel range
- ▶ Aluminum mounting duct for sensors
- ▶ Various connection accessories

PSK without cover



PSK with cover plate



PSK with sealing strip



PSK with mount and coupling and mounted motor



PSK with timing belt side drive and mounted motor



PRODUCT DESCRIPTION

Notes on lubrication versions

LSS:

- ▶ Basic lubrication by Bosch Rexroth
- ▶ Tribol GR 100-2 PD (PSK-060/-090) or Tribol GR 100-00 PD (PSK-050) grease lubricant
- ▶ Relubrication by grease gun

LPG:

- ▶ Ball Rail System and Ball Screw Assembly coated with preservative only
- ▶ Relubrication by grease gun
- ▶ Basic lubrication by user required

LCF:

- ▶ Basic lubrication by Bosch Rexroth
- ▶ Tribol GR 100-00 PD grease lubricant (NLGI grade 00)
- ▶ Prepared for connection to central liquid grease lubrication system (NLGI grade 00 as per DIN 51818)
- ▶ Optional connector available (straight or right-angled) for connecting to central lubrication systems
- ▶ Liquid grease lubrication via single-line piston distributor system only

LSC:

- ▶ Basic lubrication by Bosch Rexroth
- ▶ Tribol GR 215-2 PD or Tribol GR 100-00 PD grease lubricant depending on Rexroth Ball Screw Assembly
- ▶ Relubrication by grease gun

Form of Delivery

Precision Modules with Ball Rail System and Ball Screw Assembly come fully assembled.

Motor mounting

If a motor and motor attachment are ordered, the components come installed as shown in the figure. The position of the motor connector can also be selected. For more information on motor connector positions, see chapter “Configuration and Ordering.”

If motor attachments are ordered without a motor, some assembly will be required. All necessary information and parameters for proper mounting will be included in delivery.

Mount and coupling (F001)

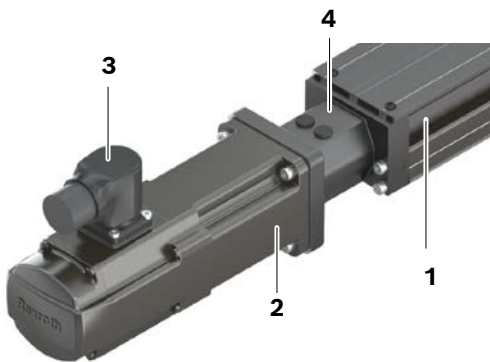

- 1 Linear Motion System
- 2 Motor
- 3 Motor connector
- 4 Mount and coupling

Timing belt side drive (S000, S090, S180, S270)

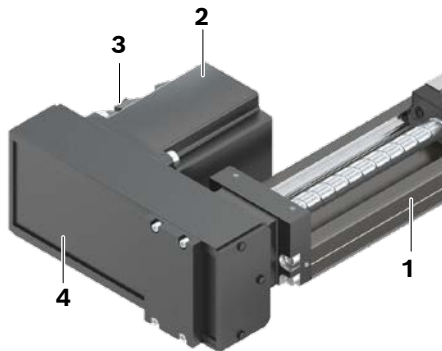

- 1 Linear Motion System
- 2 Motor
- 3 Motor connector
- 4 Timing belt side drive

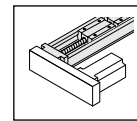

S000

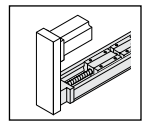

S090

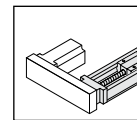

S180

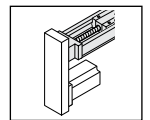

S270

Options

Mounting duct, switch bracket and sensor come unassembled.

Lubrication

Depending on the lubrication version, Precision Modules come with initial lubrication or preservation.

For information on lubricant, see chapter “Lubrication.”

Documentation

Every Precision Module comes with corresponding documentation.

Load capacities and sizes

Suitable loads (recommended values)

For the desired nominal life, loads for F_m , F_{comb} should not exceed approx. 20% of the dynamic load capacity C_{100} . See chapter “Calculation Principles.”

Make sure the technical values for the Linear Motion System are not exceeded.

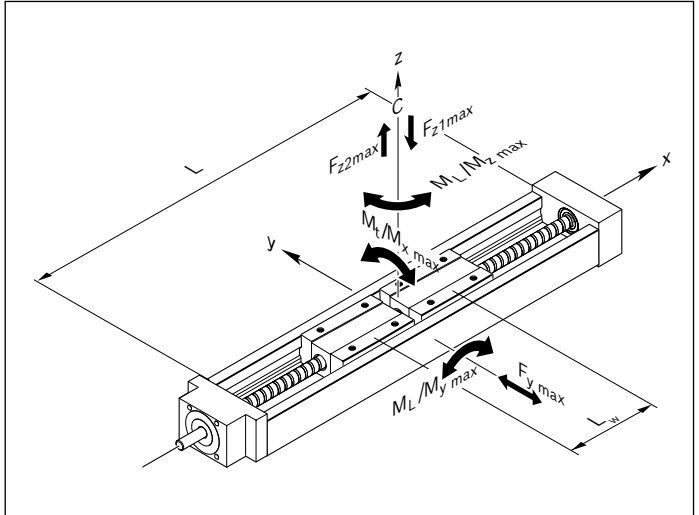

Overview of types with load capacities

Type	System	Guideway	Drive	Size	Carriage (carr.)		Dyn. load capacities	
					Version	Number	$C_{50}^{1)}$ (N)	$C_{100}^{2)}$ (N)
PSK	Precision Module	Rail System	Ball Screw Assembly	050	Long	1 carr.	11 500	9 100
						2 carr.	18 600	14 800
				060	Standard	1 carr.	11 500	9 100
						2 carr.	18 600	14 800
					Long	1 carr.	14 500	11 500
						2 carr.	23 540	18 700
				090	Standard	1 carr.	27 500	21 800
						2 carr.	44 600	35 400
					Long	1 carr.	35 300	28 000
						2 carr.	57 300	45 500

¹⁾ Dynamic load capacities and load moments are based on a 50,000 m stroke as per DIN ISO 14728-1.

²⁾ Dynamic load capacities and load moments are based on a 100,000 m stroke as per DIN ISO 14728-1.

Dimensions

PSK	050	060	090
B (B_{AP}) (mm)	50 (62)	60 (86)	86 (112)
H (H_{AP}) (mm)	26 (40)	33 (48)	46 (68)
L (mm)	100	150	340
	150	200	440
	200	300	540
	250	400	640
	300	500	740
	350	600	840
400	700	940	

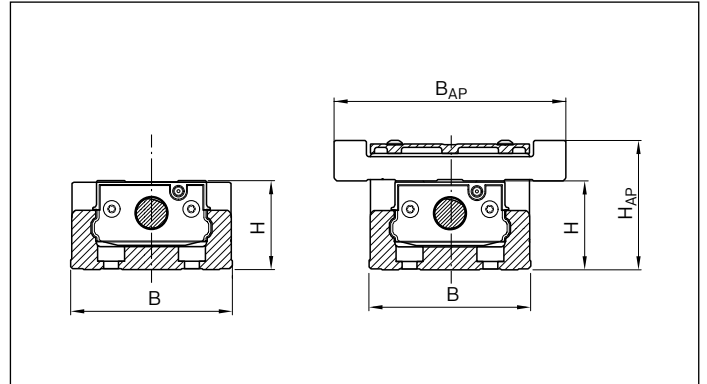

Structural Design

PSK without cover

- 1 Fixed bearing end block
- 2 Ball Screw Assembly
- 3 One or two steel carriages, standard or long
- 4 Frame with reference edge and integrated guideway geometry
- 5 Floating bearing end block
- 6 Sensor

7 Mounting duct

8 Switching cam

PSK with cover plate

9 Cover plate

10 One or two carriages, standard or long

11 Carriage plate, aluminum

12 Carriage plate guide unit, steel

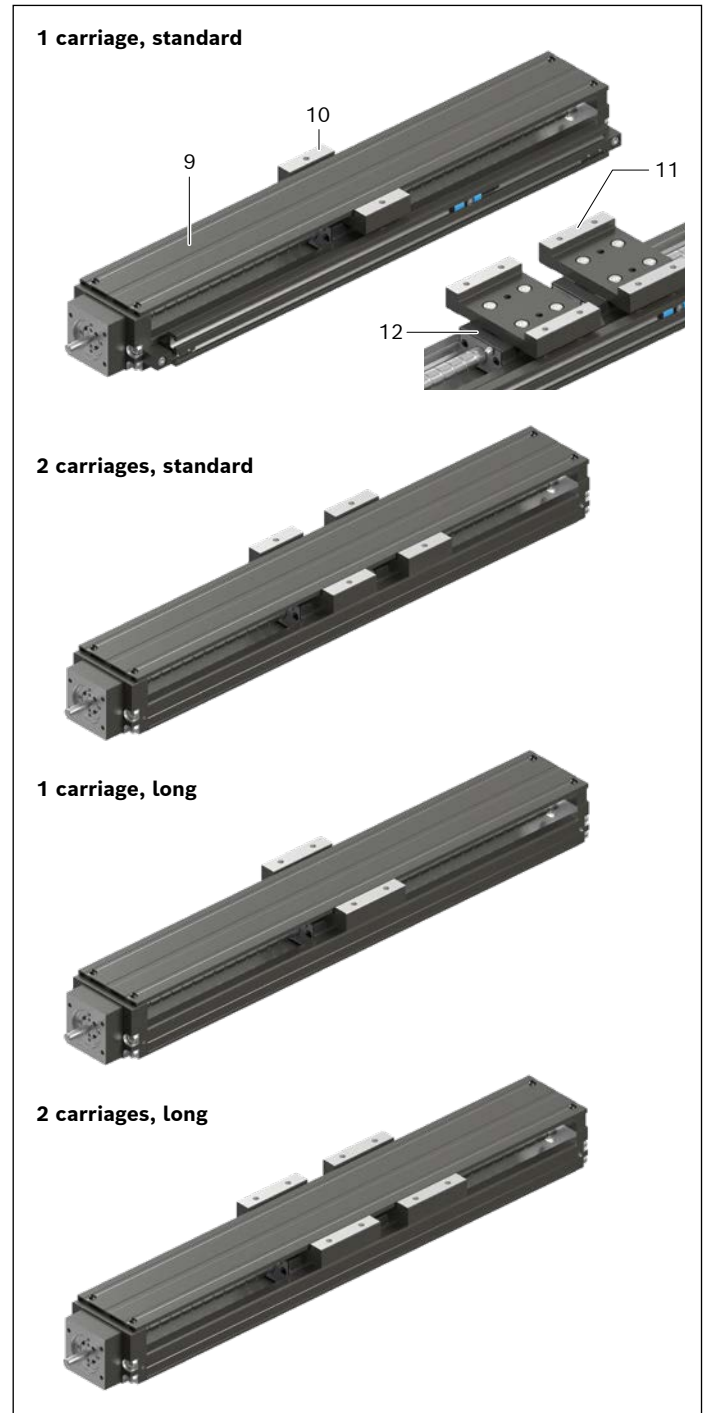
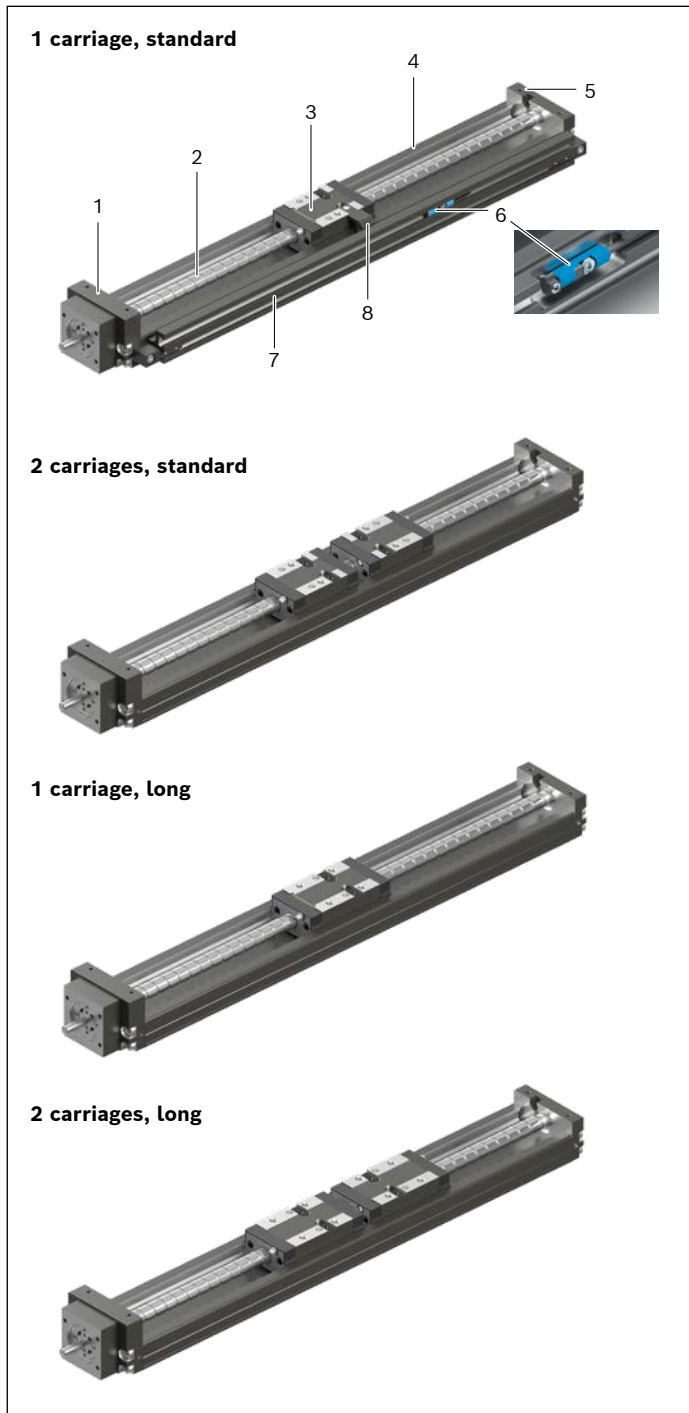

PSK with sealing strip (under preparation)

- 13** Sealing strip, stainless steel
- 14** One carriage, standard or long
- 15** Carriage plate, aluminum
- 16** Carriage, steel

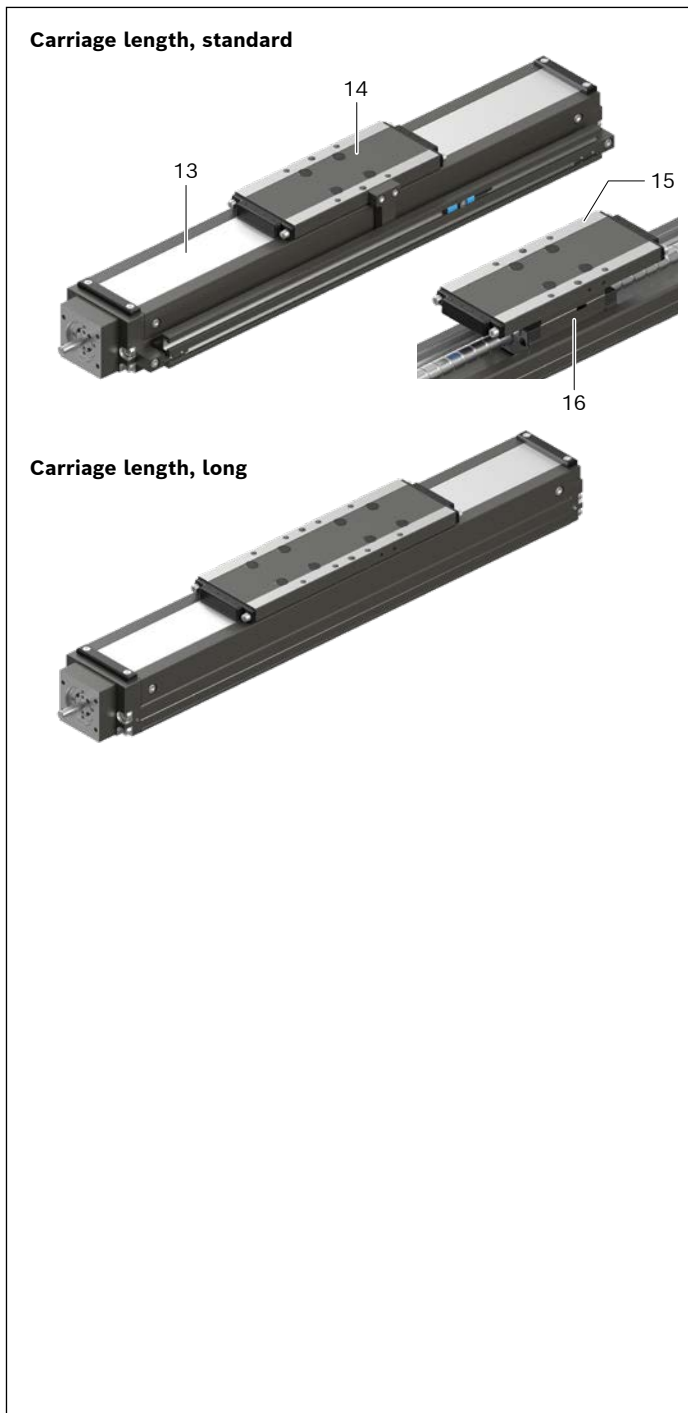
Attachments for all PSK modules

Structural Design

Without motor attachment (screw journal version)

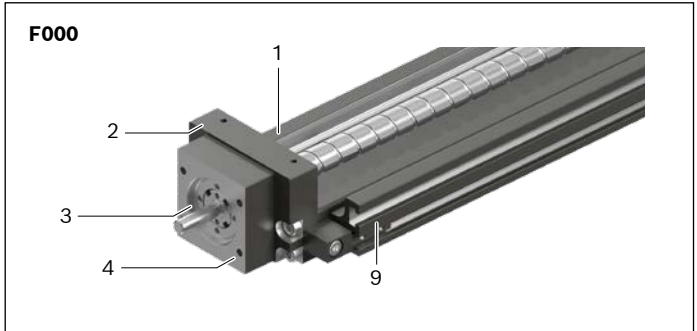

Motor attachment with mount and coupling

A motor can be attached to all Precision Modules by means of a motor mount and coupling.

Depending on its size, the motor is attached by a mount and coupling or a fixed bearing end block with integrated mount.

The mount serves to fasten the motor to the Precision Module and acts as a closed housing for the coupling. The coupling transmits the motor drive torque free of distortive stresses to the Precision Module's screw journal.

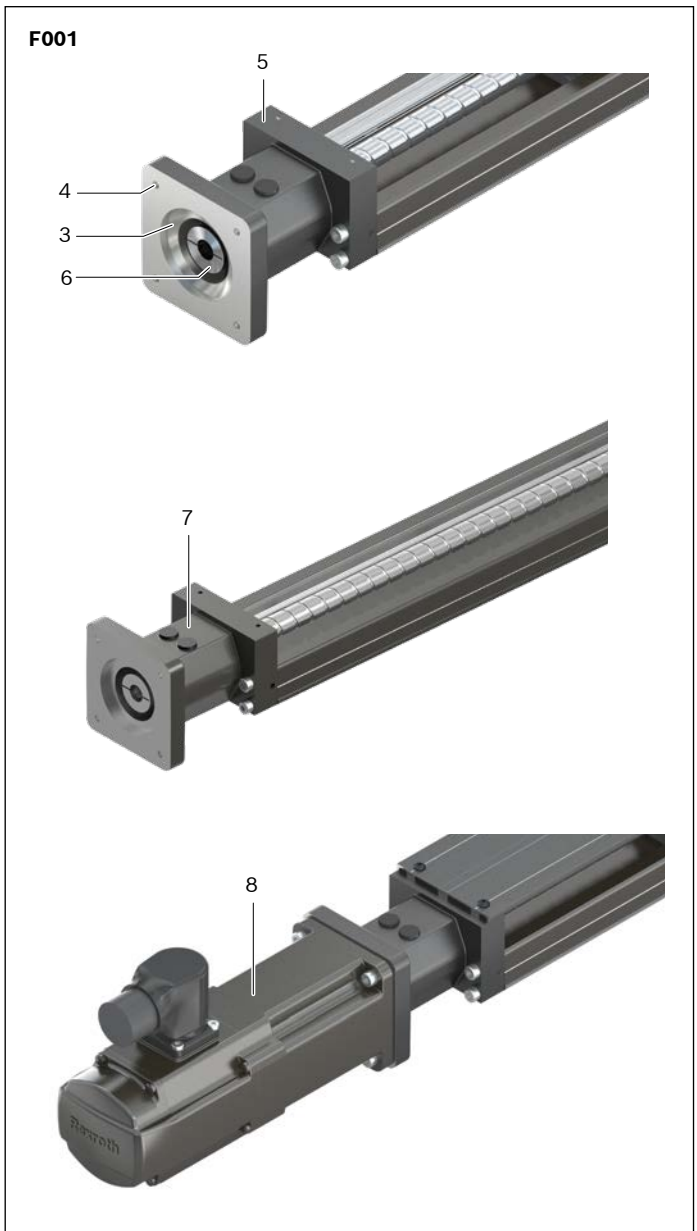

- 1 Frame
- 2 Fixed bearing end block
- 3 Motor alignment
- 4 Fastening thread
- 5 Fixed bearing end block with integrated motor mount
- 6 Coupling
- 7 Attached motor mount
- 8 Motor
- 9 Mounting duct

Motor attachment with timing belt side drive (S000–S270)

On the Precision Modules, the motor can be attached via a timing belt side drive.

This makes the overall length shorter than when attaching the motor with a mount and coupling.

The compact, closed housing protects the belt and secures the motor.

The following gear ratios are available:

- ▶ $i = 1 : 1$
- ▶ $i = 1 : 1.5$

The timing belt side drive can be mounted in four different directions:

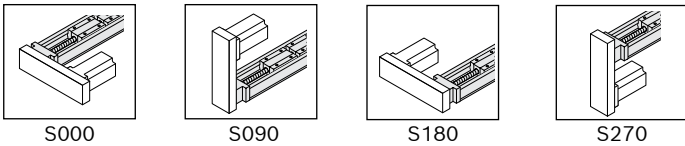

Components

- 1** Motor
- 2** Cover
- 3** Anodized aluminum pulley housing
- 4** Cover plate
- 5** Belt
- 6** Screw journal with support bearing
- 7** Belt pulleys
- 8** Precision Module

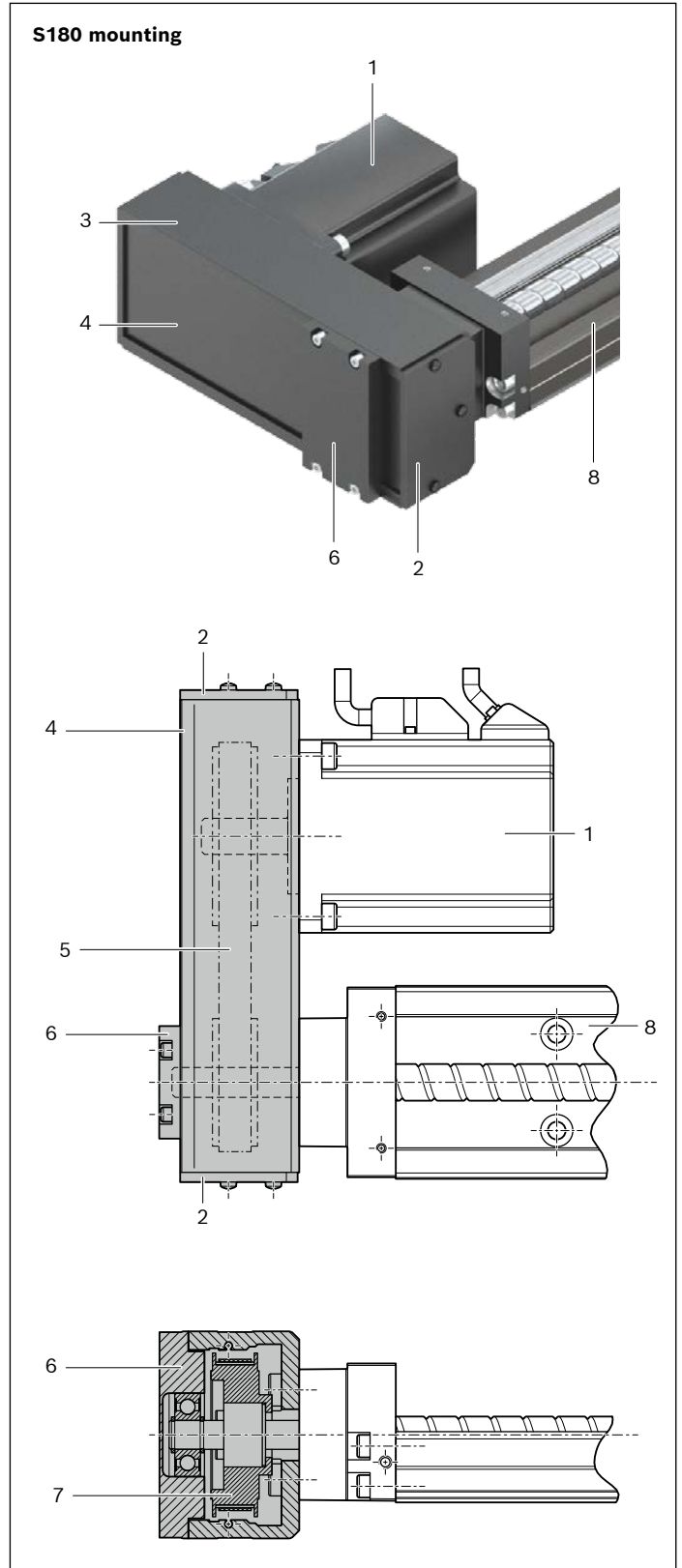

TECHNICAL DATA

Technical Data

General technical data

PSK	Carriage (carr.)		Ball Screw Assembly	Dynamic load capacities								Dynamic load moments				
	Version	Number		$d_0 \times P$ (mm)	C_{bs}			C_{fb}			$C_{gw50}^{2)}$	$C_{gw100}^{3)}$	$M_{t50}^{2)}$	$M_{t100}^{3)}$	$M_{L50}^{2)}$	$M_{L100}^{3)}$
					Accuracy class ¹⁾			Accuracy class ¹⁾			(N)	(N)	(Nm)	(Nm)	(Nm)	(Nm)
050	Long	1 carr.	8 x 1	820	1180	1920	5300	11500	9100	170	135	79	63			
			8 x 2	1790	2120											
		2 carr.	8 x 2.5	1790	2380	1920	5300	18600	14800	280	220	9.31 x L _W	7.39 x L _W			
			8 x 5	—	1800											
060	Standard	1 carr.	12 x 2	1790	2420	4200	8500	11500	9100	215	170	79	63			
			12 x 5	In preparation	4100											
	2 carr.	12 x 10	In preparation	2700	4200	8500	18600	14800	340	270	9.31 x L _W	7.39 x L _W				
		12 x 2	1790	2420									4200	8500	14500	11500
	Long	1 carr.	12 x 5	In preparation	4100											
			2 carr.	12 x 10	In preparation	2700	4200	8500	23540	18700	430	345	11.77 x L _W	9.34 x L _W		
090	Standard	1 carr.	16 x 5	9840	13320	13400									13400	27500
			16 x 10	6400	10350											
	2 carr.	16 x 16	4300	6800	13400	13400	44600	35400	1200	955	22.31 x L _W	17.71 x L _W				
		16 x 5	9840	13320									13400	13400	35300	28000
Long	1 carr.	16 x 10	6400	10350												
		2 carr.	16 x 16	4300	6800	13400	13400	57300	45500	1550	1230	28.65 x L _W	22.74 x L _W			

Observe chapter "Calculations".

For names, see chapter "Abbreviations".

¹⁾ Accuracy class: N = normal class, P = precision class. See chapter "Accuracy".

²⁾ Dynamic load capacities and load moments are based on a 50,000 m stroke as per DIN ISO 14728-1.

PSK	Carriage (carr.)		Maximum permissible loads					
	Version	Number	M_x max (Nm)	M_y max (Nm)	M_z max (Nm)	F_y max (N)	F_{z1} max (N)	F_{z2} max ⁴⁾ (N)
050	Long	1 carr.	46	22	10	1400	3600	3100
		2 carr.	74	2.95 x L _W	1.40 x L _W	2800	5900	5900
060	Standard	1 carr.	47	22	10	1400	3600	3100
		2 carr.	90	2.95 x L _W	1.40 x L _W	2800	5900	5900
	Long	1 carr.	70	44	27	2800	4600	4600
		2 carr.	112	3.75 x L _W	2.85 x L _W	5600	7400	7400
090	Standard	1 carr.	105	46	20	2000	8700	4500
		2 carr.	210	4.55 x L _W	2.00 x L _W	4000	14100	9100
	Long	1 carr.	210	127	56	4000	11200	9100
		2 carr.	420	9.10 x L _W	4.00 x L _W	7900	18200	18200

³⁾ Dynamic load capacities and load moments are based on a 100,000 m stroke as per DIN ISO 14728-1.

⁴⁾ With a lifting force of F_{z2}, the values for F_y max and M_z max must be limited to max. 75%.

PSK	Carriage (carr.)		Moved system mass Cover			Constant mass calculation Cover						Planar moment of inertia	
	Version	Number	without	with cover plate	with sealing strip	without		with cover plate		with sealing strip		I_y (cm ⁴)	I_z (cm ⁴)
			m_{ca} (kg)	m_{ca} (kg)	m_{ca} (kg)	k_g fix (kg)	k_g var (kg/mm)	k_g fix (kg)	k_g var (kg/mm)	k_g fix (kg)	k_g var (kg/mm)		
050	Long	1 carr.	0.18	0.25	In preparation	0.203	0.0041	0.209	0.0043	In preparation	In preparation	1.26	13.76
		2 carr.	0.36	0.51	In preparation								
060	Standard	1 carr.	0.25	0.35	In preparation	0.366	0.0063	0.374	0.0066	In preparation	In preparation	2.42	28.82
		2 carr.	0.52	0.72	In preparation								
	Long	1 carr.	0.34	0.48	In preparation								
		2 carr.	0.69	0.97	In preparation								
090	Standard	1 carr.	0.79	1.03	In preparation	0.638	0.0120	0.665	0.0128	In preparation	In preparation	8.71	115.31
		2 carr.	1.65	2.12	In preparation								
	Long	1 carr.	1.07	1.39	In preparation								
		2 carr.	2.20	2.84	In preparation								

Modulus of elasticity E of Linear Motion System

$$E = 210\,000 \text{ N/mm}^2$$

**Mass calculation of Linear Motion System
(without motor attachment, without motor)**

$$m_s = k_{g \text{ fix}} + k_{g \text{ var}} \cdot L + m_{ca}$$

Technical Data

PSK	Carriage (carr.)		Length (mm)						
	Version	Number	without		with cover plate		Cover with sealing strip		
			L_{ca}	L_{ad}	L_{ca}	L_{ad}		L_{Wmin}	$S_{min}^{1)}$
050	Long	1 carr.	39.3	22.6	47.4	12.4	In preparation	–	18
		2 carr.	$39.3 + L_W$	22.6	$47.4 + L_W$	12.4	In preparation	60	
060	Standard	1 carr.	39.3	20.5	40.0	19.8	In preparation	–	25
		2 carr.	$39.3 + L_W$	20.5	$40.0 + L_W$	19.8	In preparation	60	
	Long	1 carr.	53.7	20.5	55.0	19.2	In preparation	–	
		2 carr.	$53.7 + L_W$	20.5	$55.0 + L_W$	19.2	In preparation	75	
090	Standard	1 carr.	57.9	30	60.0	27.9	In preparation	–	40
		2 carr.	$57.9 + L_W$	30	$60.0 + L_W$	27.9	In preparation	90	
	Long	1 carr.	79.6	30	80.0	29.6	In preparation	–	
		2 carr.	$79.6 + L_W$	30	$80.0 + L_W$	29.6	In preparation	110	

¹⁾ Min. travel distance required to guarantee lubricant distribution. See chapter “Operating Conditions”.
If this cannot be achieved, please consult Bosch Rexroth.

PSK-050	L (mm)	s_{max} (mm) Carriage, long	
		1 carr.	2 carr.
	100		38.1
150		88.1	28.1
200		138.1	78.1
250		188.1	128.1
300		238.1	178.1
350		288.1	228.1
400		338.1	278.1

PSK-060	L (mm)	s_{max} (mm)			
		Carriage, standard		Carriage, long	
	1 carr.	2 carr.	1 carr.	2 carr.	
150		90.2	30.2	75.8	–
200		140.2	80.2	125.8	50.8
300		240.2	180.2	225.8	150.8
400		340.2	280.2	325.8	250.8
500		440.2	380.2	425.8	350.8
600		540.2	480.2	525.8	450.8
700		640.2	580.2	625.8	550.8

PSK-090	L (mm)	s_{max} (mm)			
		Carriage, standard		Carriage, long	
	1 carr.	2 carr.	1 carr.	2 carr.	
340		252.1	162.1	230.4	120.4
440		352.1	262.1	330.4	220.4
540		452.1	362.1	430.4	320.4
640		552.1	462.1	530.4	420.4
740		652.1	562.1	630.4	520.4
840		752.1	662.1	730.4	620.4
940		852.1	762.1	830.4	720.4

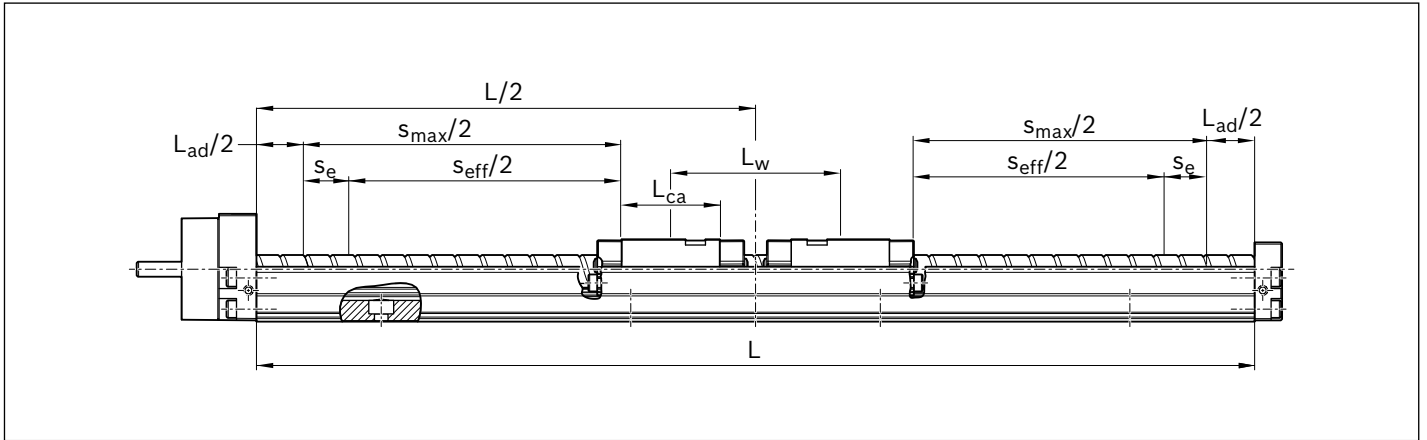
Length calculation of Linear Motion System

Length ¹⁾ :	L	$= s_{eff} + 2 \cdot s_e + L_{ca} + L_{ad}$
Excess travel:	s_e	$= 2 \cdot P$
Max. travel distance:	s_{max}	$= s_{eff} + 2 \cdot s_e$

¹⁾ See chapter "Calculations" and "Configuration and Ordering"

Technical Data

Drive data

PSK	Carriage (carr.)		Ball Screw Assembly	Constant mass moment of inertia					Friction moment	Max. acceleration	Max. drive torque	Max. speed
	Version	Number		Cover			$k_{J \text{ var}}$ (kgmm)	$k_{J \text{ m}}$ (mm ²)				
				without	with cover plate	with sealing strip						
			$d_0 \times P$ (mm)	$k_{J \text{ fix}}$ (kgmm ²)	$k_{J \text{ fix}}$ (kgmm ²)	$k_{J \text{ fix}}$ (kgmm ²)			M_{Rs} (Nm)	a_{max} (m/s ²)	M_P (Nm)	v_{max} (m/s)
050	Long	1 carr.	8 x 1	0.487	0.489	In preparation	0.004	0.025	0.03	48.4	See graphs	See graphs
			8 x 2	0.500	0.508	In preparation	0.004	0.101	0.04	50		
			8 x 2.5	0.511	0.522	In preparation	0.004	0.158	0.04	50		
			8 x 5	0.595	0.640	In preparation	0.004	0.633	0.04	50		
		2 carr.	8 x 1	0.492	0.495	In preparation	0.004	0.025	0.04	48.4		
			8 x 2	0.519	0.534	In preparation	0.004	0.101	0.04	50		
			8 x 2.5	0.540	0.562	In preparation	0.004	0.158	0.04	50		
			8 x 5	0.712	0.802	In preparation	0.004	0.633	0.05	50		
060	Standard	1 carr.	12 x 2	0.780	0.790	In preparation	0.013	0.101	0.07	48.4		
			12 x 5	0.910	0.974	In preparation	0.011	0.633	0.08	50		
			12 x 10	1.380	1.635	In preparation	0.011	2.533	0.08	50		
		2 carr.	12 x 2	0.807	0.827	In preparation	0.013	0.101	0.08	48.4		
			12 x 5	1.080	1.207	In preparation	0.011	0.633	0.08	50		
			12 x 10	2.059	2.568	In preparation	0.011	2.533	0.09	50		
	Long	1 carr.	12 x 2	0.788	0.802	In preparation	0.013	0.101	0.07	48.4		
			12 x 5	0.964	1.053	In preparation	0.011	0.633	0.08	50		
			12 x 10	1.595	1.950	In preparation	0.011	2.533	0.08	50		
		2 carr.	12 x 2	0.824	0.853	In preparation	0.013	0.101	0.08	48.4		
			12 x 5	1.188	1.366	In preparation	0.011	0.633	0.08	50		
			12 x 10	2.492	3.202	In preparation	0.011	2.533	0.10	50		
090	Standard	1 carr.	16 x 5	4.410	4.559	In preparation	0.031	0.633	0.19	50		
			16 x 10	5.909	6.505	In preparation	0.031	2.533	0.19	50		
			16 x 16	9.026	10.554	In preparation	0.034	6.485	0.19	50		
		2 carr.	16 x 5	4.953	5.251	In preparation	0.031	0.633	0.20	50		
			16 x 10	8.082	9.275	In preparation	0.031	2.533	0.21	50		
			16 x 16	14.590	17.646	In preparation	0.034	6.485	0.22	50		
	Long	1 carr.	16 x 5	4.587	4.788	In preparation	0.031	0.633	0.19	50		
			16 x 10	6.618	7.424	In preparation	0.031	2.533	0.19	50		
			16 x 16	10.842	12.905	In preparation	0.034	6.485	0.19	50		
		2 carr.	16 x 5	5.301	5.704	In preparation	0.031	0.633	0.20	50		
			16 x 10	9.475	11.087	In preparation	0.031	2.533	0.21	50		
			16 x 16	18.157	22.283	In preparation	0.034	6.485	0.23	50		

Observe chapter "Calculations".

For names, see chapter "Abbreviations".

Drive data for motor attachment via timing belt side drive

PSK	Motor	BASA d ₀ x P (mm)	Permissible torque		Reduced mass moment of inertia		Friction moment M _{Rsd} (Nm)	Mass		Belt type	
			M _{Sd} ¹⁾ (Nm) i = 1	M _{Sd} ¹⁾ (Nm) i = 1.5	J _{Sd} (10 ⁻⁶ kgm ²) i = 1	J _{Sd} (10 ⁻⁶ kgm ²) i = 1.5		m _{Sd} (kg) i = 1	m _{Sd} (kg) i = 1.5	B _t i = 1	B _t i = 1.5
050	MSM019B	8 x 1	0.21	0.14	10.70	4.10	0.06	0.27	0.25	6AT3	6AT3
		8 x 2	0.50	0.33							
		8 x 2.5	0.61	0.41							
		8 x 5	0.60	0.40							
060	MSM019B	12 x 2	0.86	0.57	10.70	4.10	0.06	0.28	0.26	6AT3	6AT3
		12 x 5	1.31	0.87							
		12 x 10	1.31	0.87							
	MSM031B	12 x 2	0.86	0.57	34.77	13.05	0.15	0.63	0.60	10AT3	10AT3
		12 x 5	2.47	1.65							
		12 x 10	2.70	1.80							
MS2N03-B	12 x 2	0.86	0.57	34.27	12.45	0.15	0.63	0.61	10AT3	10AT3	
	12 x 5	2.47	1.65								
	12 x 10	2.70	1.80								
090	MSM031C	16 x 5	2.87	1.91	41.50	13.30	0.15	0.67	0.64	10AT3	10AT3
		16 x 10	2.87	1.91							
		16 x 16	2.87	1.91							
	MSM041B	16 x 5	4.32	2.88	233.90	79.10	0.40	1.45	1.28	16AT5	16AT5
		16 x 10	5.86	3.91							
		16 x 16	6.43	4.29							
	MS2N03-B (i=1.5) MS2N03-D (i=1)	16 x 5	2.87	1.91	37.30	13.40	0.15	0.65	0.65	10AT3	10AT3
		16 x 10	2.87	1.91							
		16 x 16	2.87	1.91							
	MS2N04	16 x 5	4.32	2.88	234.40	83.60	0.40	1.42	1.32	16AT5	16AT5
16 x 10		5.86	3.91								
16 x 16		6.43	4.29								

Drive data for motor attachment via mount and coupling

PSK	Motor	Coupling	M _{CN} ¹⁾	J _c	m _{fc}
			(Nm)	(10 ⁻⁶ kgm ²)	(kg)
050	MSM019B		1.90	2.10	0.089
	MSM031B		3.70	7.00	0.300
	MS2N03-B		3.70	7.00	0.300
	NEMA-17C		-	-	0.038
060	MSM019B		1.90	2.10	0.126
	MSM031B		3.70	7.00	0.300
	MS2N03-B		1.90	2.10	0.164
	NEMA 23-D		-	-	0.123
090	MSM031C		13.00	12.00	0.370
	MSM041B		9.00	61.00	0.800
	MS2N03-B MS2N03-D		13.00	12.00	0.377
	MS2N04		19.00	57.00	0.750
	NEMA 23-D		-	-	0.272

¹⁾ Values for M_{Sd} / M_{CN} do not factor in motor torque.

Speed Graphs

Drive Torque Graphs

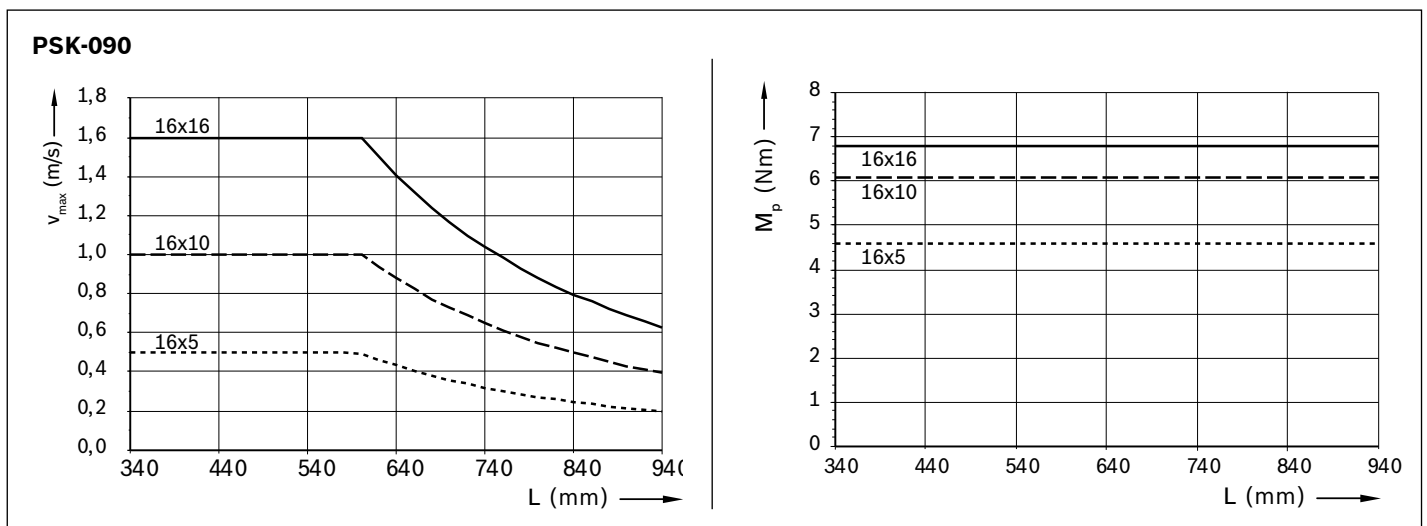
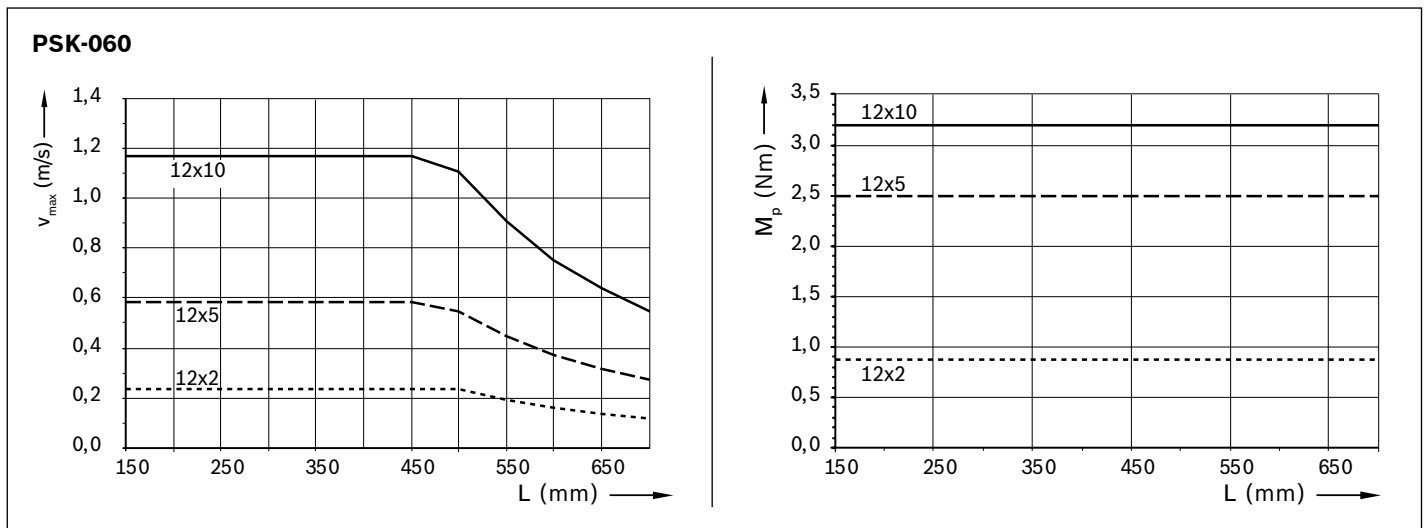
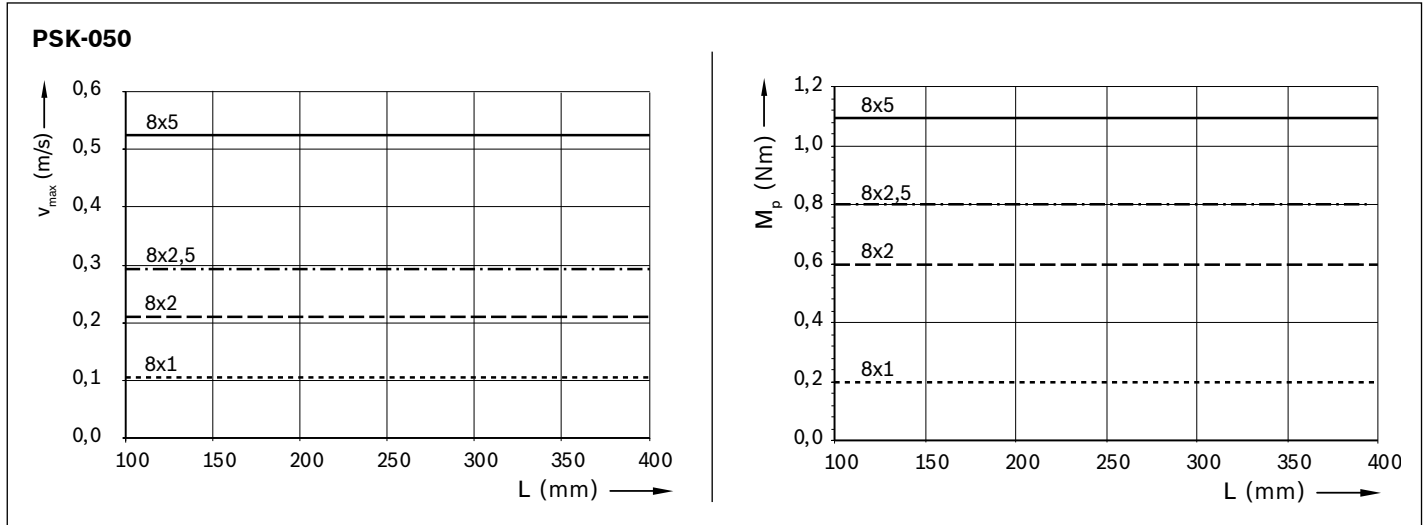

Speed and Drive Torque Values

PSK-050				
Length (mm)	100, 150, 200, 250, 300, 350, 400			
Ball Screw Assembly	8x1	8x2	8x2.5	8x5
v_{max} (m/s)	0.11	0.21	0.29	0.53
M_p (Nm)	0.20	0.60	0.80	1.10

PSK-060												
Length (mm)	150, 200, 250, 300, 400			500			600			700		
Ball Screw Assembly	12x2	12x5	12x10	12x2	12x5	12x10	12x2	12x5	12x10	12x2	12x5	12x10
v_{max} (m/s)	0.23	0.58	1.17	0.23	0.55	1.11	0.16	0.37	0.75	0.12	0.27	0.55
M_p (Nm)	0.86	2.50	3.20	0.86	2.50	3.20	0.86	2.50	3.20	0.86	2.50	3.20

PSK-090															
Length (mm)	340, 440, 540			640			740			840			940		
Ball Screw Assembly	16x5	16x10	16x16	16x5	16x10	16x16	16x5	16x10	16x16	16x5	16x10	16x16	16x5	16x10	16x16
v_{max} (m/s)	0.50	1.00	1.60	0.43	0.88	1.41	0.32	0.65	1.04	0.25	0.50	0.80	0.19	0.39	0.63
M_p (Nm)	4.60	6.10	6.80	4.60	6.10	6.80	4.60	6.10	6.80	4.60	6.10	6.80	4.60	6.10	6.80

Accuracy Graphs

General note

All accuracy figures apply to the module when screwed down and assume an ideally flat mounting base. The values given do not take account of any shape deviations in the mounting base surface.

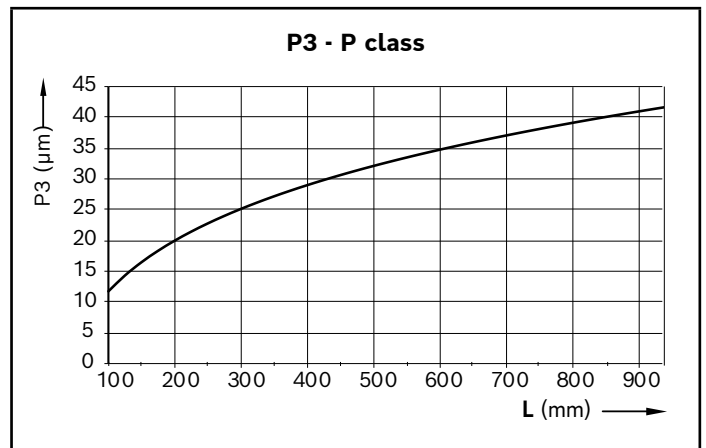
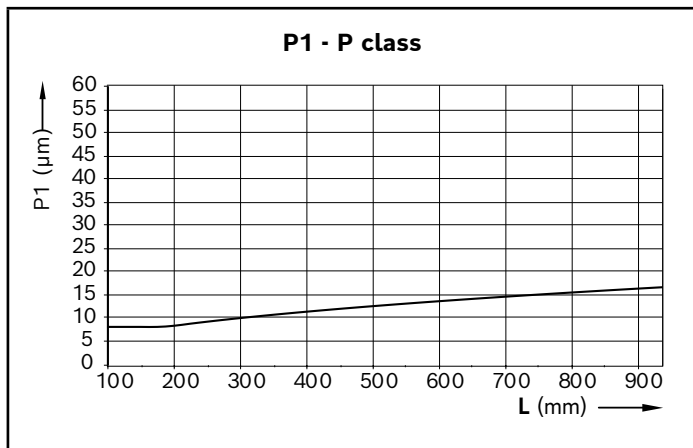
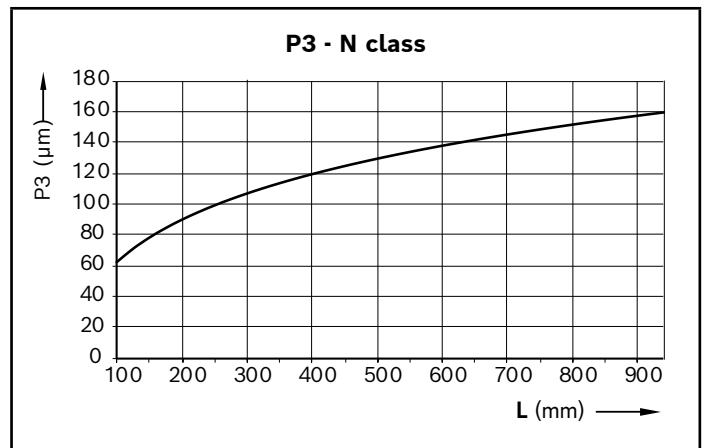
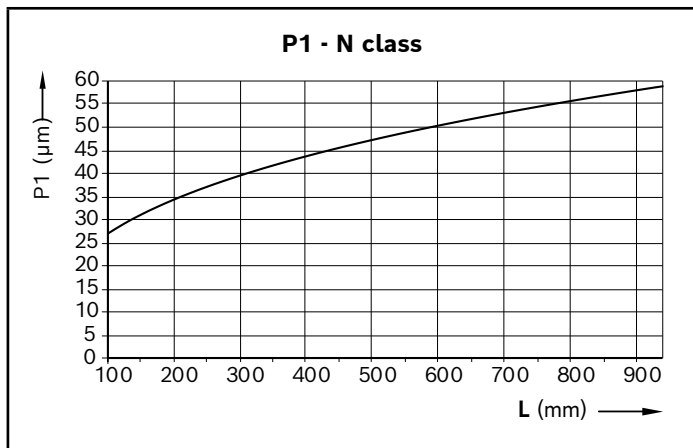
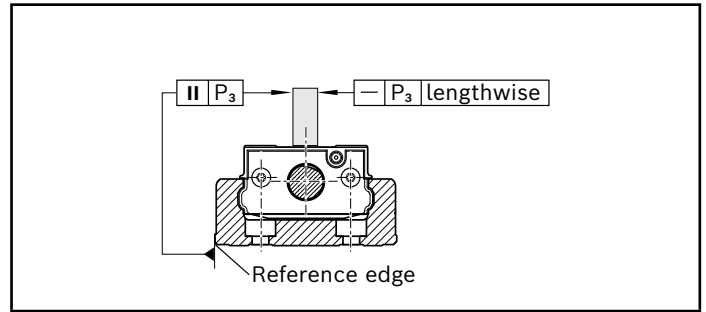
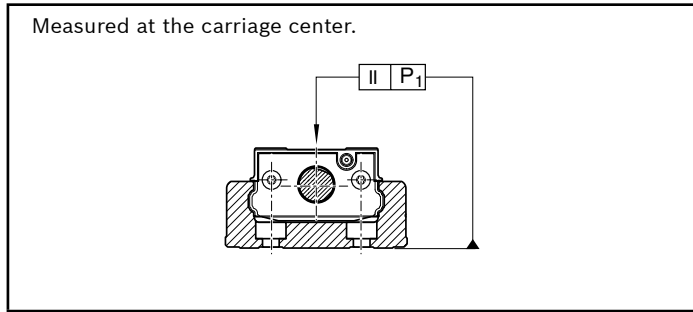

Backlash

PSK	Backlash Accuracy class	
	N (mm)	P (mm)
050	Max. 0.02 mm clearance	Max. 0.003 mm clearance
060		
090		

CALCULATIONS

Calculation Principles

Calculation principles	22
Maximum permissible loads	23
Linear guideway life	23
Ball Screw Assembly/fixed bearing life	24
Drive dimensioning	25
Principles	25
Drive dimensioning with motor shaft as reference point	26
General motor preselection	28
Calculation example	29

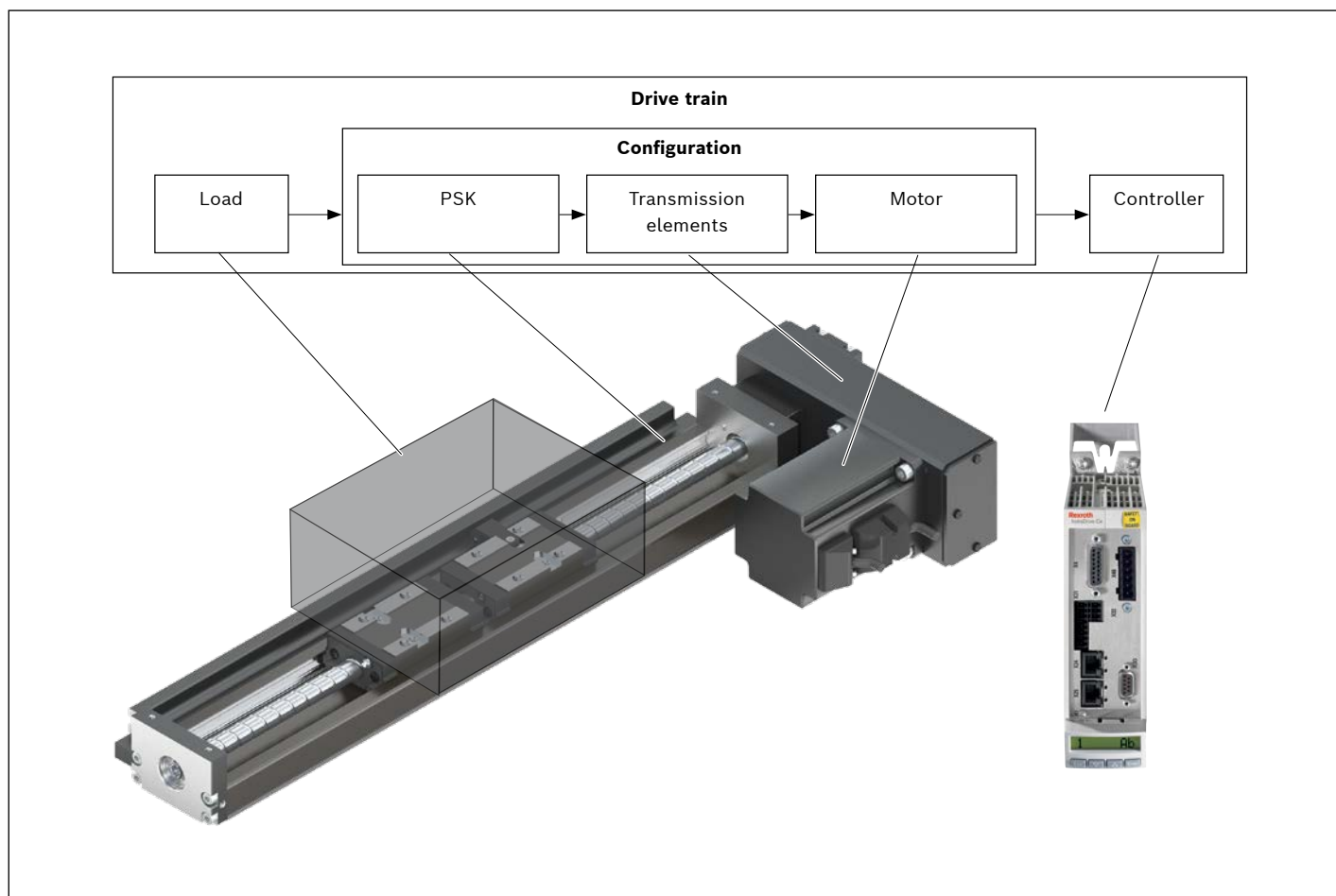

Proper sizing and suitability for an application requires a structural assessment of the entire drive train. The configuration, which comprises the Precision Module PSK, the transmission element (coupling or timing belt side drive) and the motor, forms the base of the drive train and can be ordered from the catalog in this combination.

Maximum permissible loads

When selecting a Linear Motion System, the maximum permissible loads and forces must be taken into account and can be found in the chapter “Technical Data”. The

values in this chapter are system-based, i.e. the limits are based not only on the load capacity of the bearings, but also on design/material limits.

Conditions for combined loads

$$\frac{|F_y|}{F_{y \max}} + \frac{|F_z|}{F_{z \max}} + \frac{|M_x|}{M_{x \max}} + \frac{|M_y|}{M_{y \max}} + \frac{|M_z|}{M_{z \max}} \leq 1$$

Linear guideway life

The life of the roller bearings in a Linear Motion System can be determined with the following formulas. The roller bearings that determine the life of a Linear Motion System

with Ball Screw Assembly are the linear guideway, the ball screw assembly (nut) and the fixed bearing.

△ The life of the Linear Motion System is the separately calculated life that is the shortest (for linear guideway, ball screw assembly or fixed bearing).

The linear guideway in the Linear Motion System must withstand the load as well as any process forces that occur.

Combined equivalent load on guideway bearing

	z ₁ (mm)	
	without cover	cover plate
PSK-050	13.0	27.0
PSK-060	17.5	32.5
PSK-090	24.5	46.5

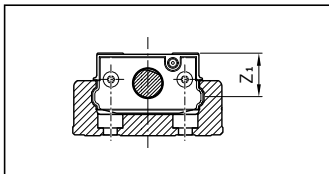

Nominal life in meters

$$F_{\text{comb}} = |F_y| + |F_z| + C \cdot \frac{|M_x|}{M_t} + C \cdot \frac{|M_y|}{M_L} + C \cdot \frac{|M_z|}{M_L}$$

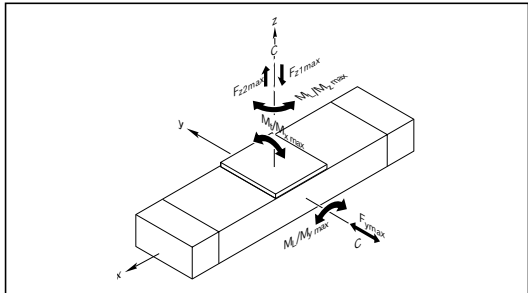

$$L = \left(\frac{C_{100}}{f_w \cdot F_{\text{comb}}} \right)^3 \cdot 10^5 \text{ m}$$

Impact loads and vibrations cause additional loads on the contact point between ball and running track. Determining the exact conditions of use is difficult. However, the additional

loads increase as travel velocity increases. The load factor f_w (see table) factors in the effects of impacts and vibrations on life.

Conditions of use	Travel velocity	Load factor f _w
No impact loads and vibrations	v < 0.25 m/s	1.0 ... 1.2
Low impact loads and vibrations	0.25 m/s ≤ v < 1 m/s	1.2 ... 1.5
Moderate impact loads and vibrations	1 m/s ≤ v < 2 m/s	1.5 ... 2.0
High impact loads and vibrations	v ≥ 2 m/s	2.0 ... 3.5

Nominal life in hours

$$L_h = \frac{L}{3\,600 \cdot v}$$

Calculation Principles

Ball Screw Assembly/fixed bearing life

Under variable operating conditions (variable speed and load), the means F_m and n_m have to be used when calculating life.

With variable speed, the following applies to mean speed n_m :

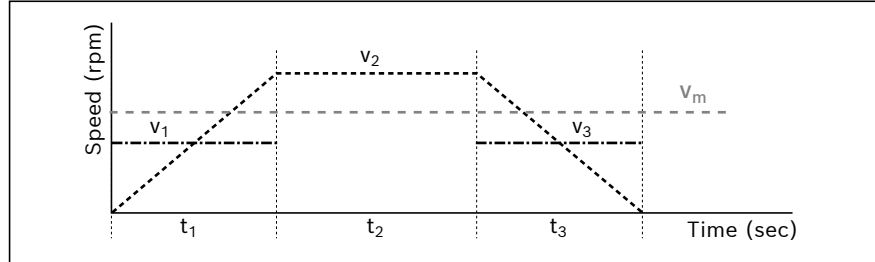

$$n_m = \frac{|n_1| \cdot t_1 + |n_2| \cdot t_2 + \dots + |n_n| \cdot t_n}{t_{total}}$$

$$t_{total} = t_1 + t_2 + \dots + t_n$$

Speed in acceleration and braking phases $n_{1 \dots n}$:

$$n_{1 \dots n} = \frac{n_{A1 \dots n} + n_{E1 \dots n}}{2}$$

With variable load and speed, the following applies to mean load F_m :

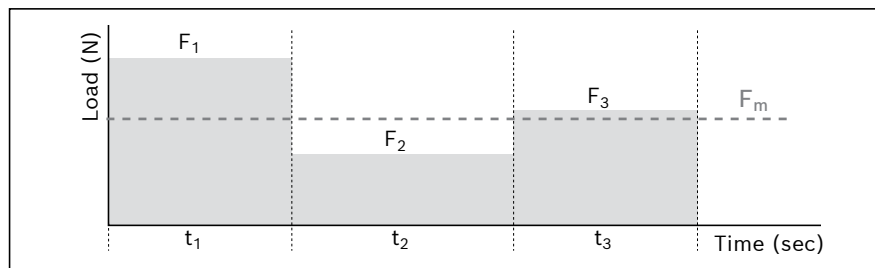

$$F_m = \sqrt[3]{|F_1|^3 \cdot \frac{|n_1|}{n_m} \cdot \frac{t_1}{t_{ges}} + |F_2|^3 \cdot \frac{|n_2|}{n_m} \cdot \frac{t_2}{t_{ges}} + \dots + |F_n|^3 \cdot \frac{|n_n|}{n_m} \cdot \frac{t_n}{t_{ges}}}$$

Nominal life

Nominal life in revolutions:

$$L = \left(\frac{C}{F_m} \right)^3 \cdot 10^6$$

Nominal life in hours:

$$L_h = \frac{L}{n_m \cdot 60}$$

Drive Dimensioning

Principles

For drive dimensioning, the drive train can be divided into the mechanical and drive groups. The mechanical group comprises the Linear Motion System and transmission elements (timing belt side drive, coupling), and factors in load.

A motor/controller combination with the corresponding performance values is characterized as an electric drive. The electric drive is dimensioned using the motor shaft as the reference point. For drive dimensioning, both the limits and the base values have to be taken into account. The limits must not be exceeded in order to protect the mechanical components from being damaged.

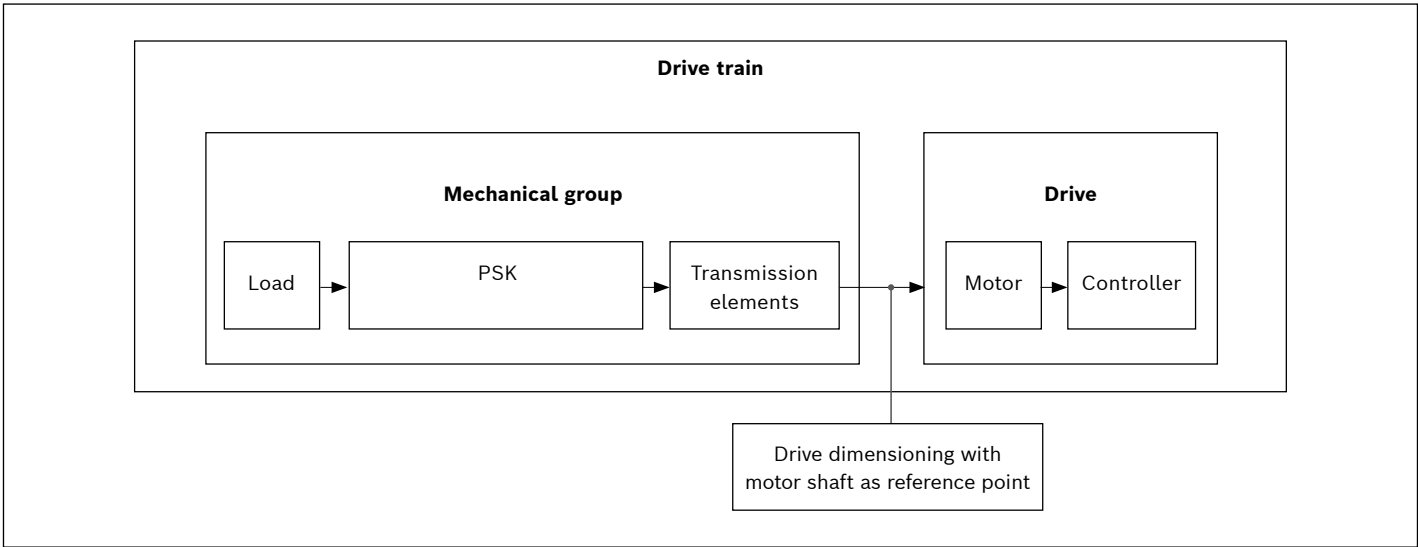

Technical data and formula symbols for mechanical group

For every component (Linear Motion System, coupling, timing belt side drive), the corresponding maximum permissible limits for drive torque and speed, and the base values for friction moment and mass moment of inertia have to be used.

The following technical data with corresponding formula symbols are used for the mechanical group when assessing the drive dimensioning principles. The data listed in the table below can be found in the chapter “Technical Data” or is determined using formulas based on the descriptions on the following pages.

		Mechanical group			
		Load	Linear Motion System	Coupling	Timing belt side drive
Torque	(Nm)	$M_g^{6)}$	—	—	—
Friction moment	(Nm)	— ⁵⁾	$M_{Rs}^{3)}$	—	$M_{Rsd}^{3)}$
Mass moment of inertia	(kgm ²)	$J_t^{1)}$	$J_s^{2)}$	$J_c^{3)}$	$J_{sd}^{3)}$
Max. permissible velocity	(m/s)	—	$v_{max}^{4)}$	—	—
Max. permissible drive torque	(Nm)	—	$M_p^{4)}$	$M_{cN}^{3)}$	$M_{sd}^{3)}$

1) Use formula to find value
 2) Based on length, use formula to find value
 3) See table for value
 4) Based on length, see graph
 5) Additional process forces should be considered load torque
 6) When installed vertically: use formula to find value

Drive Dimensioning

Drive dimensioning with motor shaft as reference point

For drive dimensioning, all relevant calculated values for the mechanical components in the drive train must be combined or reduced to the motor shaft. For a combination of mechanical components in the drive train, this produces a value for:

- Friction moment M_R
- Mass moment of inertia J_{ex}
- Max. permissible velocity v_{mech} (max. permissible speed n_{mech})
- Max. permissible drive torque M_{mech}

Determination of values for each mechanical component in drive train using motor shaft as reference point

Friction moment M_R

For motor attachment via mount and coupling

$$M_R = M_{Rs}$$

For motor attachment via timing belt side drive

$$M_R = M_{Rsd} + \frac{M_{Rs}}{i}$$

Mass moment of inertia J_{ex}

For motor attachment via mount and coupling

$$J_{ex} = J_s + J_t + J_c$$

For motor attachment via timing belt side drive

$$J_{ex} = J_{sd} + \frac{(J_s + J_t)}{i^2}$$

Determination of mass moment of inertia of Linear Motion System components

$$J_s = (k_{J_{fix}} + k_{J_{var}} \cdot L) \cdot 10^{-6}$$

Determination of translatory mass moment of inertia of external load

$$J_t = m_{ex} \cdot k_{J_m} \cdot 10^{-6}$$

Maximum permissible velocity v_{mech}

The lowest permissible velocity of all of the mechanical components in the drive train is the maximum permissible velocity of the mechanical group, which must be considered the drive limit when dimensioning the motor.

Depending on the system, the maximum permissible velocity/speed of the Linear Motion System with Ball

Screw Assembly is always below the limits for the coupling or timing belt side drive components, meaning it determines the maximum permissible velocity of the mechanical group.

Maximum permissible velocity

$$v_{\text{mech}} = v_{\text{max}}$$

Maximum permissible speed

For motor attachment via mount and coupling

$$n_{\text{mech}} = \frac{v_{\text{mech}} \cdot 1000 \cdot 60}{p}$$

For motor attachment via timing belt side drive

$$n_{\text{mech}} = \frac{v_{\text{mech}} \cdot i \cdot 1000 \cdot 60}{p}$$

Maximum permissible drive torque M_{mech}

The lowest (minimum) permissible drive torque of all of the mechanical components in the drive train is the maximum permissible drive torque of the mechanical group,

which must be considered the drive limit when dimensioning the motor.

For motor attachment via mount and coupling

$$M_{\text{mech}} = \text{minimum} (M_{\text{cN}}; M_{\text{p}})$$

For motor attachment via timing belt side drive

$$M_{\text{mech}} = \text{minimum} (M_{\text{sd}}; \frac{M_{\text{p}}}{i})$$

△ When considering the entire drive train (mechanical group + motor/controller), the maximum motor speed can also be under the limit for the mechanical group (M_{mech}), meaning it is the maximum permissible drive torque of the drive train. If the maximum motor speed is above the limit for the mechanical group (M_{mech}), the maximum motor speed must be limited to the permissible value for the mechanical group.

Drive Dimensioning

General motor preselection

The motor can be generally preselected using the following conditions:

Condition 1:

The motor speed must be greater than or equal to the necessary speed for the mechanical group (up to maximum permissible limit).

$$n_{\max} \geq n_{\text{mech}}$$

Condition 2:

Consider the ratio of mass moments of inertia of the mechanical group and motor. The ratio of mass moments of inertia serves as an indicator for the control quality of a

motor/controller combination. The mass moment of inertia of the motor is directly related to its size.

Ratio of mass moments of inertia

$$V = \frac{J_{\text{ex}}}{J_{\text{m}} + J_{\text{br}}}$$

For preselection, the following rules of thumb can be used for high control quality.

These are not hard limits, however values above these limits require a closer examination of the application.

Application area	V
Handling	≤ 6.0
Machining	≤ 1.5

Condition 3:

Estimate the torque ratio from the static load torque to the continuous motor torque. The torque ratio must be less than or equal to an empirical value of 0.6. This condition roughly factors in the missing dynamic characteristics

of an exact motion profile with the necessary motor torques.

Torque ratio

$$\frac{M_{\text{stat}}}{M_0} \leq 0.6$$

Static load torque

$$M_{\text{stat}} = M_{\text{R}} + M_{\text{g}}$$

Torque

Only when installed vertically.

For motor attachment via mount and coupling: $i = 1$

$$M_{\text{g}} = \frac{P \cdot (m_{\text{ex}} + m_{\text{ca}}) \cdot g}{2000 \cdot \pi \cdot i}$$

In the chapter ["Configuration and Ordering,"](#) standardized configurations that include motor attachment and motor can be created for the various Linear Motion System sizes by selecting options. Meeting the above conditions

can be used to check whether a standard motor selected in the configuration is generally suitable for the application in terms of size.

Exact drive dimensioning

General motor preselection is no substitute for an exact drive calculation with a detailed focus on torque and speed. For an exact calculation of the electric drive that includes the underlying motion profile, the performance data from the “Rexroth Drive Technology” catalogs must be used.

For drive dimensioning, the maximum permissible limits for speed, drive torque and acceleration should not be exceeded in order to protect the mechanical group from being damaged.

Calculation Example

Given data

A mass of 20 kg is to be moved 340 mm at a maximum velocity of 0.6 m/s.

Module selected based on the technical data and the connection dimensions:

- PSK-090 without cover and with a standard carriage and motor attachment via mount and coupling
- Motor type: MS2N03-DOBYN

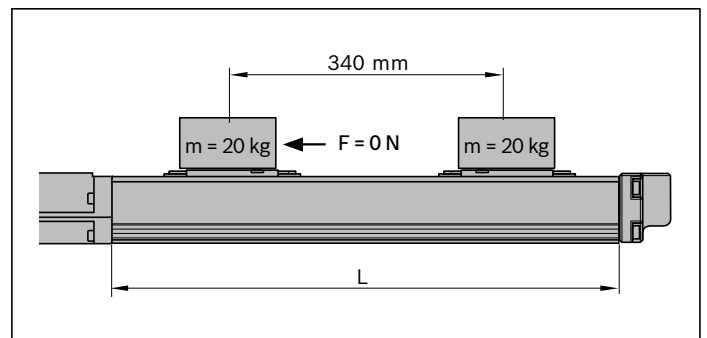

Estimation of length L

(For an initial estimate, the greatest possible lead, thus the length, is calculated, since the permissible velocity can decrease as length increases.)

	$L = s_{\text{eff}} + 2 \cdot s_e + L_{\text{ca}} + L_{\text{ad}}$
Excess travel:	$s_e = 2 \cdot P = 2 \cdot 16 = 32 \text{ mm}$
Max. travel distance:	$s_{\text{max}} = s_{\text{eff}} + 2 \cdot s_e$ $= 340 + 2 \cdot 32 = 404 \text{ mm}$
Length:	$L = 404 + 79.6 + 30 = 513.6 \text{ mm}$
Selected:	Standard length $L = 540 \text{ mm}$

Selection of Ball Screw Assembly

(Ideally, select the lowest lead, since it is favorable to braking distance decay, length.)

Permissible Ball Screw Assembly per graph
at $v = 0.6 \text{ m/s}$ and $L = 540 \text{ mm}$: Ball screw drive 16 x 10 and ball screw drive 16 x 16
Selected Ball Screw Assembly (lower lead): Ball screw drive 16 x 10
v_{max} for ball screw drive 16 x 10 from chart: $= 1.0 \text{ m/s}$

Calculation of length L

(For selected ball screw drive)

Excess travel:	$s_e = 2 \cdot P = 2 \cdot 10 = 20 \text{ mm}$
Max. travel distance:	$s_{\text{max}} = s_{\text{eff}} + 2 \cdot s_e$ $= 340 + 2 \cdot 20 = 380 \text{ mm}$
Length:	$L = 380 + 79.6 + 30 = 489.6 \text{ mm}$
Selected:	Standard length $L = 540 \text{ mm}$

Calculation Example (Cont'd)**Friction moment M_R**

$$M_R = M_{R_s} = 0.19 \text{ Nm (see "Technical Data")}$$

Mass moment of inertia J_{ex}

Moment

$$\text{of inertia: } J_{ex} = J_s + J_t + J_c$$

$$\begin{aligned} \text{PSK: } J_s &= (k_{J \text{ fix}} + k_{J \text{ var}} \cdot L) \\ &= (5.909 + 0.031 \cdot 540 \text{ mm}) \cdot 10^{-6} = 22.649 \cdot 10^{-6} \text{ kgm}^2 \end{aligned}$$

$$\begin{aligned} \text{External load: } J_t &= m_{ex} \cdot k_{J m} \cdot 10^{-6} \\ &= 20 \text{ kg} \cdot 2.533 \cdot 10^{-6} \text{ kgm}^2 = 50.66 \cdot 10^{-6} \text{ kgm}^2 \end{aligned}$$

$$J_c = 12 \cdot 10^{-6} \text{ kgm}^2$$

$$\begin{aligned} \text{Coupling: } J_{ex} &= (22.649 + 50.66 + 12) \cdot 10^{-6} \text{ kgm}^2 = 85.309 \cdot 10^{-6} \\ &\text{kgm}^2 \end{aligned}$$

Maximum permissible speed n_{mech}

Mechanical group limit

$$\text{Max. permissible velocity: } n_{mech} = \frac{(v_{mech} \cdot 1000 \cdot 60)}{P}$$

$$v_{mech} = v_{max} = 1.0 \text{ m/s}$$

$$\text{Max. permissible speed: } n_{mech} = \frac{(1.0 \cdot 1000 \cdot 60)}{10} = 6000 \text{ rpm}$$

Maximum permissible application speed n_{mech}

Application limit

$$\text{Velocity: } v_{mech} = 0.6 \text{ m/s}$$

$$\text{Speed: } n_{mech} = \frac{0.6 \cdot 1000 \cdot 60}{10} = 3600 \text{ rpm}$$

Maximum permissible drive torque M_{mech}

Mechanical group limit

$$M_{mech} = \text{minimum } (M_{cN}; M_p)$$

$$\text{Coupling: } M_{cN} = 13 \text{ Nm (for MS2N03-D0BYN)}$$

$$\text{PSK: } M_p = 6.1 \text{ Nm}$$

$$\text{Drive torque: } M_{mech} = \text{minimum } (13; 6.1) = 6.1 \text{ Nm}$$

Motor preselection check

Selected motor:
MS2N03-D0BYN with brake

Condition 1:

Speed: $n_{\max} \geq n_{\text{mech}}$; $9000 \geq 3600$ Condition met – motor selection OK

Condition 2:

$$\text{Mass moment of inertia ratio: } V = \frac{J_{\text{ex}}}{J_{\text{m}} + J_{\text{br}}}$$

$$\text{Motor inertia: } J_{\text{m}} = 37 \cdot 10^{-6} \text{ kgm}^2$$

$$\text{Brake inertia: } J_{\text{br}} = 7 \cdot 10^{-6} \text{ kgm}^2$$

$$\text{Mass moment of inertia ratio: } V = \frac{85.309 \cdot 10^{-6}}{(37 \cdot 10^{-6} + 7 \cdot 10^{-6})} = 1.94$$

$$\text{Handling condition: } V \leq 6$$

$1.94 \leq 6$ Condition met – motor selection OK

Condition 3:

$$\text{Torque ratio: } \leq 0.6$$

$$\text{Static load torque: } M_{\text{stat}} = M_{\text{R}} + M_{\text{g}} \text{ (installed horizontally } M_{\text{g}} = 0)$$

$$= 0.19 \text{ Nm}$$

$$\text{Continuous motor torque: } M_0 = 1.15 \text{ Nm}$$

$$\text{Torque ratio: } \frac{0.19}{1.15} = 0.17$$

$0.17 \leq 0.6$ Condition met – motor selection OK

All three conditions met \Rightarrow Selected motor suitable for application.

Result**PSK-090**

$L = 540 \text{ mm}$; $s_{\max} = 447 \text{ mm}$; $L_{\text{ca}} = 57.9 \text{ mm}$; $d_0 = 16 \text{ mm}$; $P = 10 \text{ mm}$;
Without cover; motor attachment via mount and coupling;
Motor preselection: MS2N03-D0BYN with brake.

For the exact dimensioning of the electric drive, the motor/controller combination always has to be factored in, since the performance data (e.g. maximum useful speed and maximum torque) depends on the controller used. The following data should be taken into account:

$$\text{Friction moment: } M_{\text{R}} = 0.19 \text{ Nm}$$

$$\text{Mass moment of inertia: } J_{\text{ex}} = 85.309 \cdot 10^{-6} \text{ kgm}^2$$

$$\text{Velocity: } v_{\text{mech}} = 0.6 \text{ m/s (} n_{\text{mech}} = 3600 \text{ rpm)}$$

$$\text{Drive torque limit: } M_{\text{mech}} = 6.1 \text{ Nm}$$

\Rightarrow The motor torque must be limited to 6.1 Nm on the drive side.

$$\text{Acceleration limit: } a_{\max} = 50 \text{ m/s}^2$$

$$\text{Velocity limit: } v_{\text{mech}} = 1 \text{ m/s (} n_{\text{mech}} = 6000 \text{ rpm)}$$

Aside from the preferred type MS2N03-D0BYN, other motors with identical mounting dimensions can be adapted, although the limits should not be exceeded.

CONFIGURATION AND ORDERING

PSK-050-NN-2

Accuracy class	Length ¹⁾ L (mm)	Reference edge		Lubrication ²⁾	Cover			Drive BASA d ₀ x P	Carriage		
		Left	Right		without	with cover plate	with sealing strip		Length Long	Quantity	
N = normal class P = precision class	100			LSS				8 x 1			
	150										
N	200			LPG				8 x 2			
	250	L	R		0	1	2		L	1	2
P	300			LCF				8 x 2,5			
	350										
	400			LSC				8 x 5 ⁷⁾			

¹⁾ For length calculation, see chapter "Technical Data".

²⁾ See chapter "Lubrication and Maintenance".

³⁾ Attachment kit also available without motor. When ordering, enter motor type "000".

For attachment kits according to customer specifications, see chapter "Attachment Kits for Motors according to Customer Specifications".

With servo motor attached, product only available as assembled in the chapter "Form of Delivery" (note position of motor connector).



⁴⁾ Use motors complying with the appropriate NEMA specification.

Because of the varying shaft dimensions for NEMA-specification motors, the attachment kit does not include a coupling.

⁵⁾ Permissible motor connector position (for "with motor" option only). For mechanical interface without motor: select option "000".

⁶⁾ For more information, see chapter "Switching System".

⁷⁾ Not in Accuracy class N

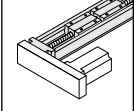
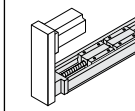
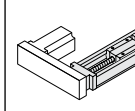
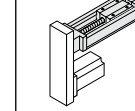
Version	Mounting interface ³⁾		Motor						Switching system ⁶⁾		Documentation
	Gear ratio	Mechanical interface	Motor code	Connector		Brake		Motor connector position ⁵⁾			
				1 cable	2 cables	with	without				
			F000 	-	-	-	-	-			
			F001 	-	-	-	-	-			
F001 (with flange)	i = 1.0	MSM019B	MSM019B-0300	-	2	Y	N	000 090 180 270	000 000	001 Standard report 002 Friction torque 003 Lead deviation 004 Running accuracy 005 Position uncertainty	
		MSM031B	MSM031B-0300	-	2						
		MS2N03-B	MS2N03-B0BYN	1	2						
		NEMA 17-C ⁴⁾	-	-	-						
			 S000	 S090	 S180	 S270					
S000 S090 S180 S270 (with timing belt side drive)	i = 1.0	MSM019B	MSM019B-0300	-	2	Y	N	000 090 180 270	120 Sensor (PNP NC) 121 Sensor (NPN NC) 122 Sensor (PNP NO) 123 Sensor (NPN NO)	001	001 Standard report 002 Friction torque 003 Lead deviation 004 Running accuracy 005 Position uncertainty

Mount	Motor connector position			
	0°	90°	180°	270°
F001	000	090 ★	180	270

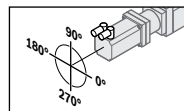

Example:
Mount F001
Motor connector position 90°

Timing belt side drive	Motor connector position			
	0°	90°	180°	270°
S000	-	090	180 ★	270
S090	000	090 ★	180	-
S180	000 ★	090	-	270
S270	000	-	180	270 ★

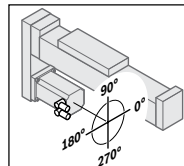

Example:
Timing belt side drive S270
Motor connector position 180°

★ Standard delivery (connector position)

CONFIGURATION AND ORDERING

PSK-060-NN-2

Accuracy class	Length ¹⁾ L (mm)	Reference edge		Lubrication ²⁾	Cover			Drive BASA d ₀ x P	Carriage			
		Left	Right		without	With cover plate	with sealing strip		Standard	Long	Number	
N = normal class P = precision class	150											
	200			LSS				12 x 2				
N	250											
	300			LPG								
P	400	L	R		0	1	2	12 x 5 ⁷⁾	S	L	1	2
	500			LCF								
	600											
	700			LSC				12 x 10 ⁷⁾				

¹⁾ For length calculation, see chapter "Technical Data".

²⁾ See chapter "Lubrication and Maintenance".

³⁾ Attachment kit also available without motor. When ordering, enter motor type "000".

For attachment kits according to customer specifications, see chapter "Attachment Kits for Motors according to Customer Specifications".

With servo motor attached, product only available as assembled in the chapter "Form of Delivery" (note position of motor connector).



⁴⁾ Use motors complying with the appropriate NEMA specification.

Because of the varying shaft dimensions for NEMA-specification motors, the attachment kit does not include a coupling.

⁵⁾ Permissible motor connector position (for "with motor" option only). For mechanical interface without motor: select option "000".

⁶⁾ For more information, see chapter "Switching System".

⁷⁾ Not in Accuracy class N

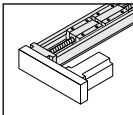
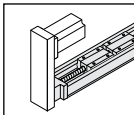
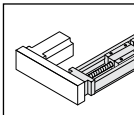
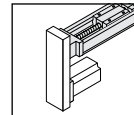
Version	Mounting interface ³⁾		Motor					Switching system ⁶⁾		Documentation
	Gear ratio	Mechanical interface	Motor code	Connector		Brake		Motor connector position ⁵⁾		
				1 cables	2 cables	with	without			
			F000 							
F000 (without mount)	-	-	-	-	-	-	-	-	000 Without sensor	000 Without mounting duct, without switching cam
			F001 							
F001 (with flange)	i = 1.0	MSM019B	MSM019B-0300	-	2	Y	N	000	120 Sensor (PNP NC) 121 Sensor (NPN NC) 122 Sensor (PNP NO) 123 Sensor (NPN NO)	001 With mounting duct, with switching cam
		MSM031B	MSM031B-0300	-	2			090		
		MS2N03-B	MS2N03-B0BYN	1	2			180		
		NEMA 23-D ⁴⁾	-	-	-			270		
										
S000 S090 S180 S270 (with timing belt side drive)	i = 1.0 i = 1.5 i = 1.0 i = 1.5 i = 1.0 i = 1.5	MSM019B	MSM019B-0300	-	2	Y	N	000 090 180 270		

- 001 Standard report
- 002 Friction torque
- 003 Lead deviation
- 004 Running accuracy
- 005 Position uncertainty

Mount	Motor connector position			
	0°	90°	180°	270°
F001	000	090 ★	180	270

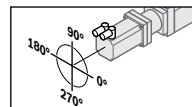

Example:
Mount F001
Motor connector position 90°

Timing belt side drive	Motor connector position			
	0°	90°	180°	270°
S000	-	090	180 ★	270
S090	000	090 ★	180	-
S180	000 ★	090	-	270
S270	000	-	180	270 ★

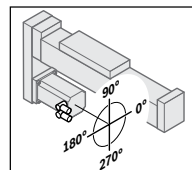



Example:
Timing belt side drive S270
Motor connector position 180°

★ Standard delivery (connector position)

CONFIGURATION AND ORDERING

PSK-090-NN-2

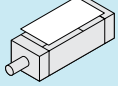
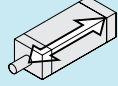
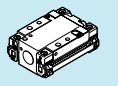
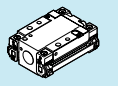
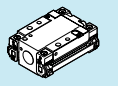
Accuracy class	Length ¹⁾	Reference edge		Lubrication ²⁾	Cover			Drive	Carriage			
		Left	Right		without	With cover plate	with sealing strip		Standard	Long	Number	
N = normal class P = precision class	L (mm)									Length		
								BASA d ₀ x P				
N	340			LSS				16 x 5				
	440											
	540			LPG								
	640	L	R		0	1	2	16 x 10	S	L	1	2
P	740			LCF								
	840											
	940			LSC				16 x 16				

¹⁾ For length calculation, see chapter "Technical Data".

²⁾ See chapter "Lubrication and Maintenance".

³⁾ Attachment kit also available without motor. When ordering, enter motor type "000".

For attachment kits according to customer specifications, see chapter "Attachment Kits for Motors according to Customer Specifications".



With servo motor attached, product only available as assembled in the chapter "Form of Delivery" (note position of motor connector).

⁴⁾ Use motors complying with the appropriate NEMA specification.

Because of the varying shaft dimensions for NEMA-specification motors, the attachment kit does not include a coupling.

⁵⁾ Permissible motor connector position (for "with motor" option only). For mechanical interface without motor: select option "000".

⁶⁾ For more information, see chapter "Switching System".

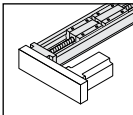
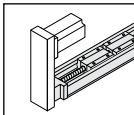
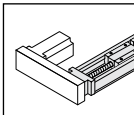
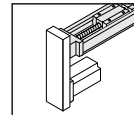
Version	Mounting interface ³⁾		Motor					Switching system ⁶⁾		Documentation
	Gear ratio	Mechanical interface	Motor code	Connector 1 cables 2 cables	Brake with without	Motor connector position ⁵⁾				
			F000 							
F000 (without mount)	-	-	-	-	-	-				
			F001 							
F001 (with flange)	i = 1.0	MSM031C	MSM031C-0300	-	2	Y	N	000 090 180 270	000 090 180 270	
		MSM041B	MSM041B-0300	-	2					
		MS2N03-B	MS2N03-BOBYN	1	2					
		MS2N03-D	MS2N03-DOBYN	1	2					
		MS2N04	MS2N04-COBTN	1	2					
		NEMA 23-D ⁴⁾	-	-	-					
										
S000 S090 S180 S270 (with timing belt side drive)	i = 1.0	MSM031C	MSM031C-0300	-	2	Y	N	000 090 180 270	000 090 180 270	
	i = 1.5	MSM041B	MSM041B-0300	-	2					
	i = 1.0	MS2N03-D	MS2N03-DOBYN	1	2					
	i = 1.5	MS2N03-B	MS2N03-BOBYN	1	2					
	i = 1.0	MS2N04	MS2N04-COBTN	1	2					
	i = 1.5	MS2N04	MS2N04-BOBTN	1	2					

Mount	Motor connector position			
	0°	90°	180°	270°
F001	000	090 ★	180	270

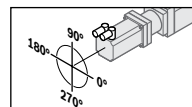

Example:
Mount F001
Motor connector position 90°

Timing belt side drive	Motor connector position			
	0°	90°	180°	270°
S000	-	090	180 ★	270
S090	000	090 ★	180	-
S180	000 ★	090	-	270
S270	000	-	180	270 ★

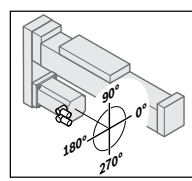

Example:
Timing belt side drive S270
Motor connector position 180°

★ Standard delivery (connector position)

DIMENSIONAL DRAWINGS

PSK without Cover

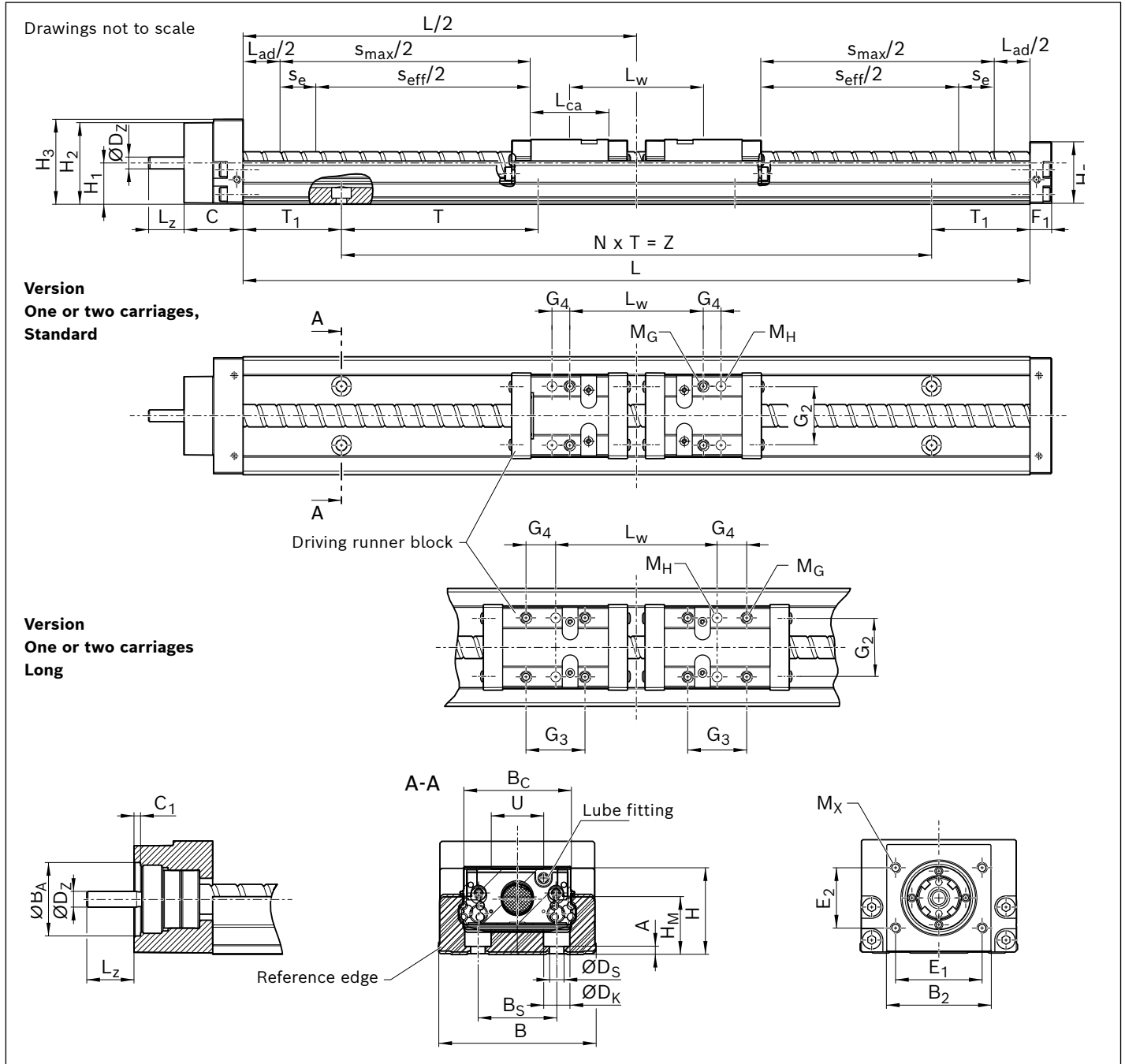

PSK	Dimensions (mm)																							
	A	B	B ₂	B ₃	∅B _A	B _{AP}	B _C	B _S	C	C ₁	∅D _K	∅D _S	∅D _Z	E ₁	E ₂	F ₁	G ₂	G ₂	G ₃	G ₄	G ₄	H	H ₁	H ₂
					H7								h7				Cover with- out	with		Carriage Stand- ard	Long			
050	2.5	50	32.8	47	25	62	33.7	25	28.5	2.5	8	4.5	5	23	23	10	25	55	30	-	15	26	16	32.5
060	3.1	60	40.0	62	28	86	40.7	30	30.0	2.5	10	5.5	6	33	23	11	30	74	30	9	15	33	21	41.5
090	4.5	86	54.5	88	40	112	59.4	46	38.0	2.5	11	6.5	9	40	28	13	46	100	46	15	23	46	29	51.5

PSK with Cover Plate

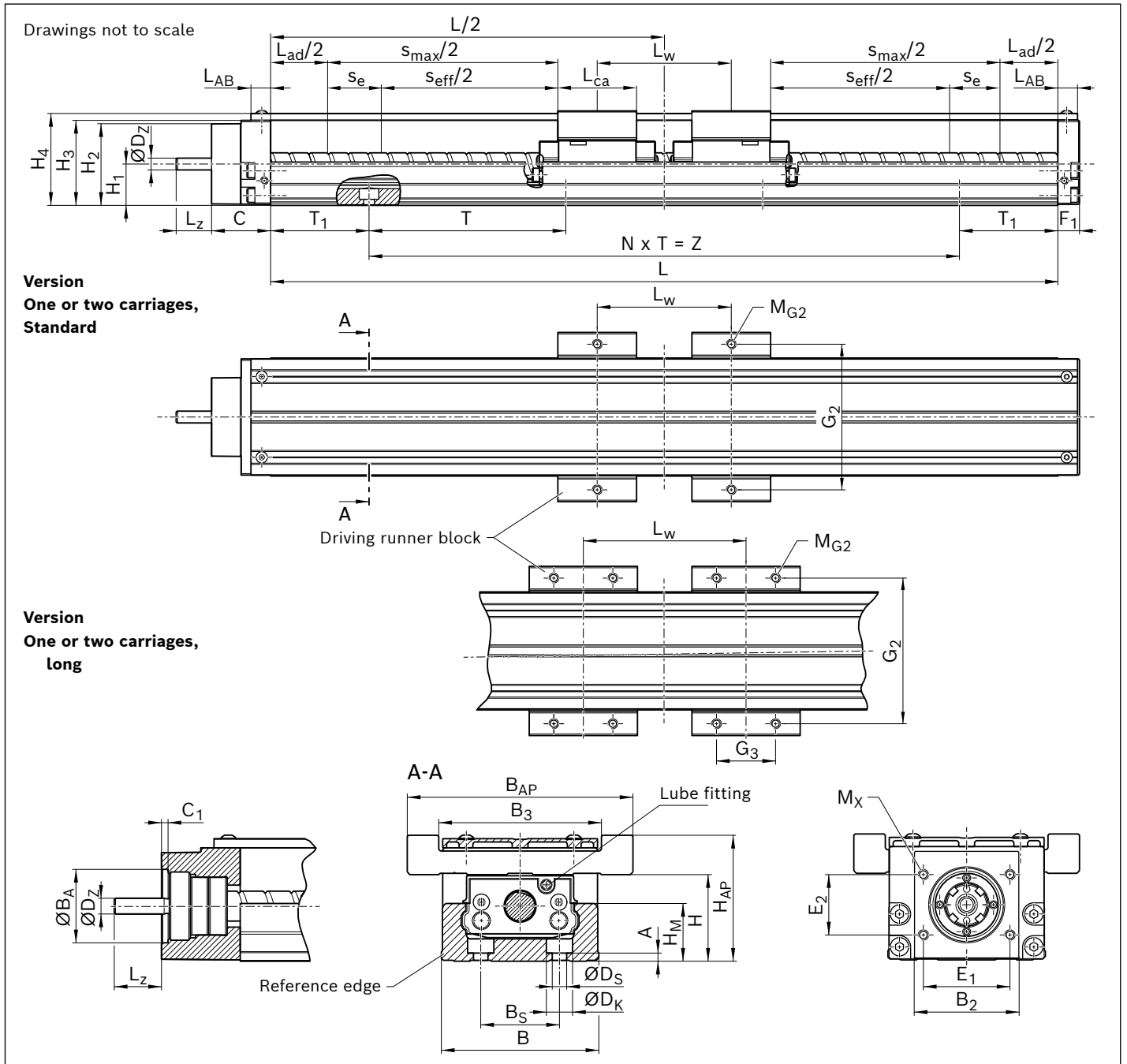

H ₃	H ₄	H ₅	H _{AP}	H _M	L _{AB}	L _{ca}	L _{w min}	L _{w min}	L _Z	M _G	M _{G2}	M _H	M _X	T	T ₁	U				
Carriage																				
Standard																				
Long																				
Standard																				
Long																				
Cover																				
without																				
with																				
35.0	37.5	25.5	40	19	9.0	-	39.3	53.7	40	55	60	75	18	M4-6.0 deep	M4-14 deep	Ø4 ^{H7} -5 deep	M3-8 deep	80	see chapter mounting	6
43.2	46.7	31.9	48	22	10.0	39.3	53.7	40	55	60	75	18	M5-8.5 deep	M5-15 deep	Ø5 ^{H7} -8 deep	M4-8 deep	100	20		
59.0	65.0	44.0	68	30	12.5	57.9	79.6	60	80	90	110	25	M6-9.0 deep	M6-22 deep	Ø6 ^{H7} -8 deep	M6-12 deep	100	33		

DIMENSIONAL DRAWINGS

PSK with Sealing Strip (under preparation)

**Under
Preparation**

This page intentionally left blank

Motor attachment with mount and Coupling

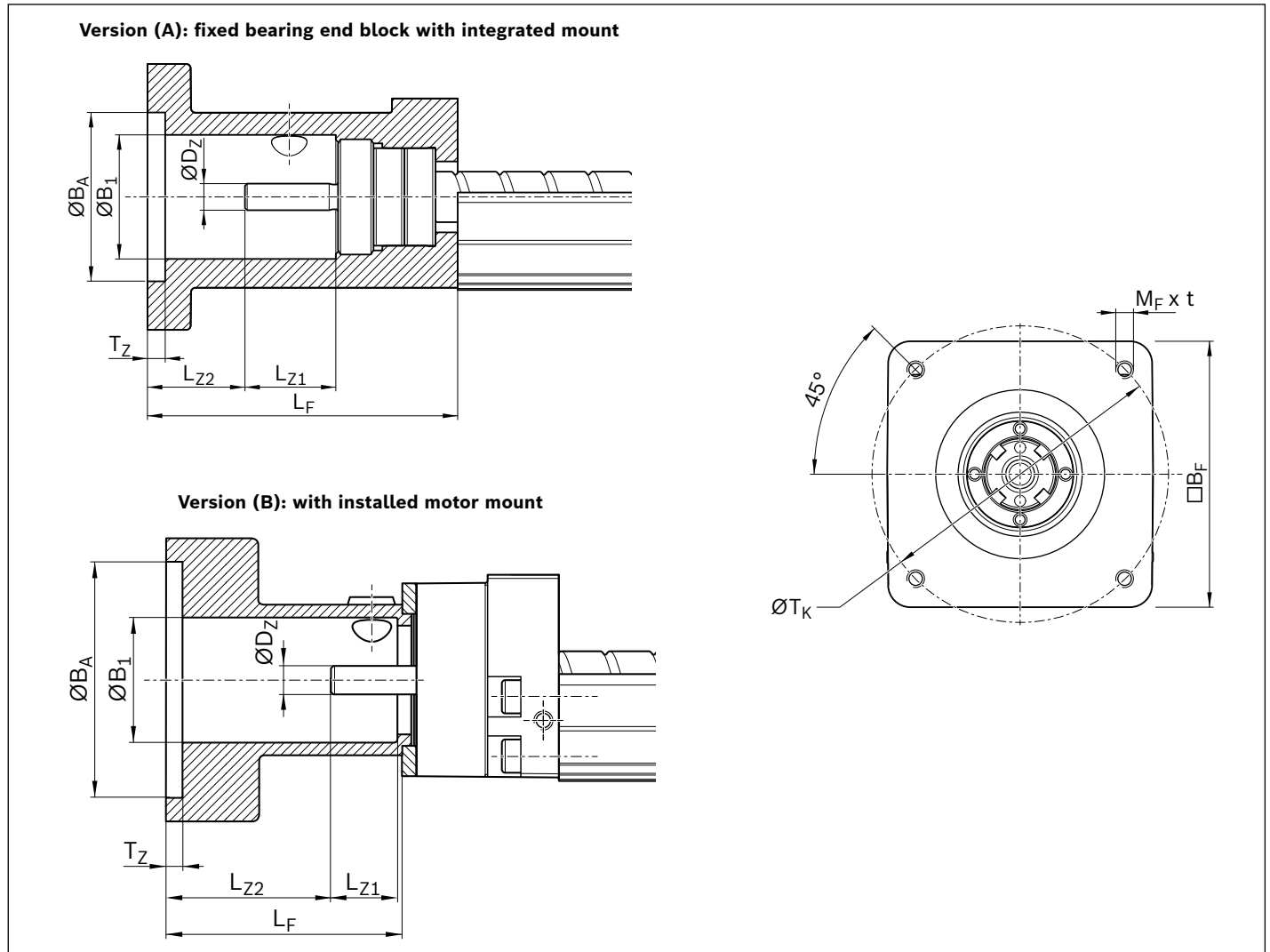

PSK	Motor	Dimensions (mm)											
		ØBA H7	ØB1	Bf	ØDz h7	Lf (A)	Lf (B)	Lz1	Lz2	Mf	t	ØTK	Tz
050	MSM019B	30	26.0	42	5	70.0	-	17.5	26.5	M3	7	45.00	4.0
	MSM031B	50	26.5	60	5	-	52.0	12.5	37.0	M4	9	70.00	4.0
	MS2N03-B	40	26.5	54	5	-	52.0	12.5	37.0	M4	9	63.00	3.5
	Nema 17-C ¹⁾	22	26.0	42	5	65.0	-	17.5	21.5	Ø3.3	8	43.80	4.0
060	MSM019B	30	28.0	40	6	75.0	-	20.5	27.0	M3	7	45.00	4.0
	MSM031B	50	26.5	60	6	-	50.0	17.0	32.0	M4	10.5	70.00	3.5
	MS2N03-B	40	28.0	60	6	70.0	-	20.5	22.0	M4	10	63.00	4.0
	Nema 23-D	38.1	28.0	60	6	70.0	-	20.5	22.0	M4	10	66.68	4.0
090	MSM031C	40	39.0	60	9	103.0	-	27.0	40.0	M4	8	70.00	4.0
	MSM041B	70	42.0	80	9	-	83.0	25.0	58.0	M5	15	90.00	3.5
	MS2N03	40	39.0	60	9	103.0	-	27.0	40.0	M4	10	63.00	4.0
	MS2N04	50	37.0	82	9	-	77.5	25.0	52.5	M6	11	95.00	3.0
	Nema 23-D	38.1	39.0	60	9	103.0	-	27.0	40.0	M4	10	66.68	4.0

¹⁾ Because of the varying shaft dimensions for NEMA-specification motors, the attachment kit does not include a coupling. Mf: Ø3.3 mm as drill hole

Motor Attachment with Timing Belt Side Drive

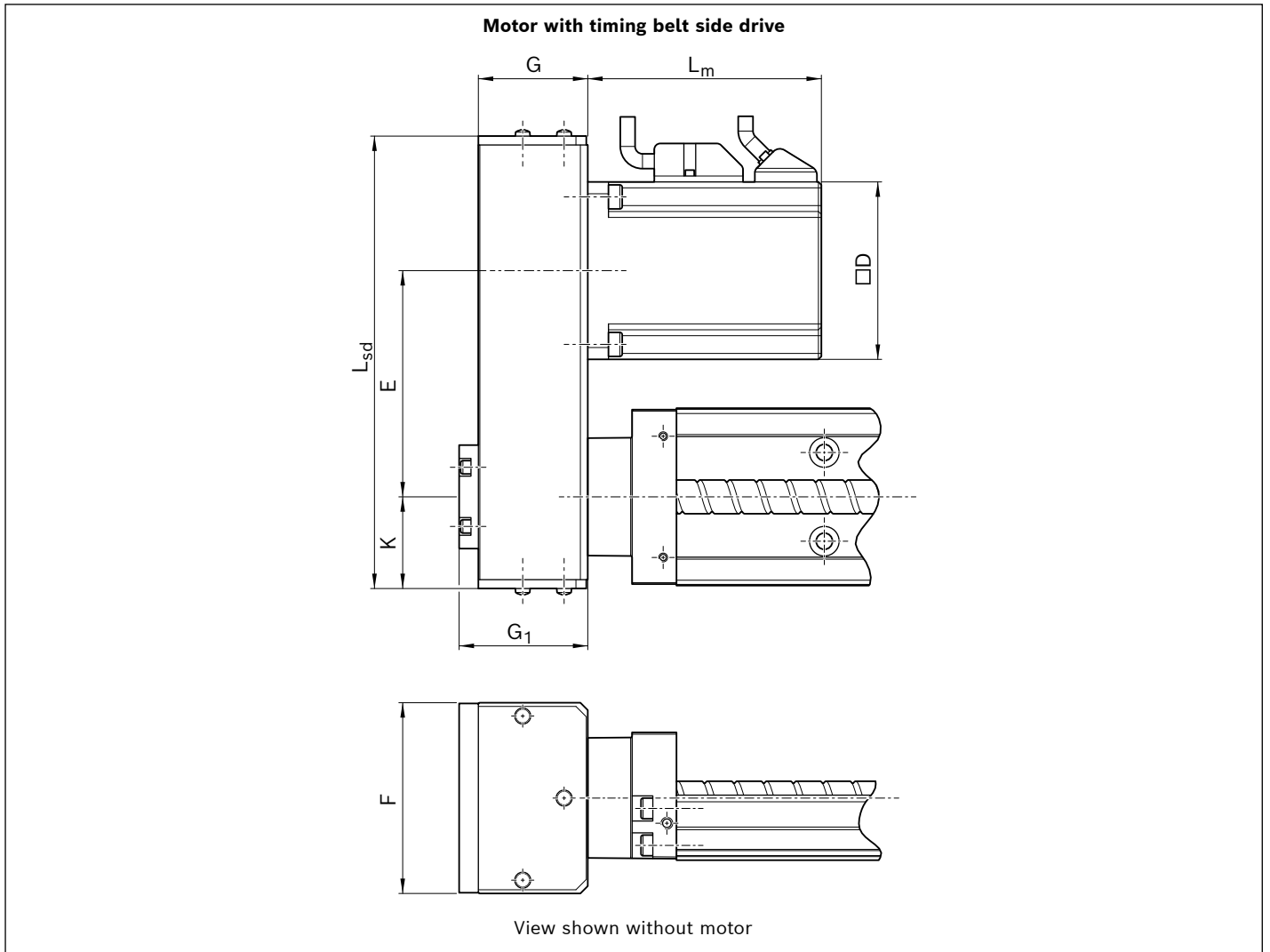

PSK	Motor	Dimensions (mm)									L _m	
		D	E i = 1	E i = 1.5	F	G	G ₁	K	L _{sd} i = 1	L _{sd} i = 1.5	with brake	without brake
050	MSM019B	38	76.5	76.5	48.0	27.5	29.0	27.5	139	139.0	See motor dimensional drawings	
	MSM019B	38	76.5	76.5	48.0	27.5	29.0	27.5	139	139.0		
060	MSM031B	60	78.0	75.0	64.5	37.0	43.5	33.5	154	154.0		
	MS2N03-B	54	78.0	75.0	64.5	37.0	43.5	33.5	154	154.0		
090	MSM031C	60	103.5	115.0	64.5	37.0	43.5	33.5	180	191.5		
	MSM041B	80	122.0	122.0	88.0	51.0	57.0	45.5	231	231.0		
	MS2N03	54	103.5	115.0	64.5	37.0	43.5	33.5	180	191.5		
	MS2N04	80	122.0	122.0	88.0	51.0	57.0	45.5	231	231.0		

ATTACHMENTS AND ACCESSORIES

Motor attachment kits according to customer specifications

The motor attachment for Linear Motion Systems with Ball Screw Assembly consists of either a mounting kit with mount and coupling (MF) or a timing belt side drive (SD). The available combinations are shown in the “Components and Ordering” selection tables for the respective size. In addition to motor options for Rexroth motors, kits

for motors can also be ordered according to customer specifications. In order to establish the appropriate mounting set, the connection geometry of the motor is crucial. Characteristics required to uniquely determine the motor geometry are shown below.

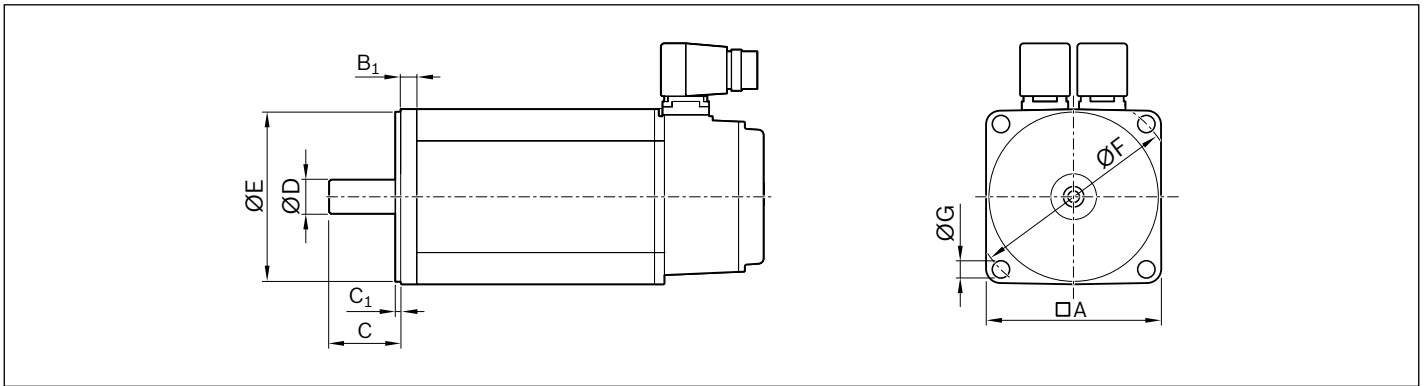

The dimensions queried result in a unique “motor geometry code”:

	□ □ - □ □ - □ □ □ - □ □ □ - □ □ □ - □ □ □ - □ □ □ - □ □ □
ØD = Shaft diameter	
C = Shaft length	
ØE = Centering diameter	
C₁ = Centering depth	
ØF = Pitch diameter	
ØG = Drill hole for mounting screw (specify thread diameter)	
B₁ = Flange thickness	
A = Flange edge dimension	

Example representation of servo motor IndraDyn S Type MS2N04

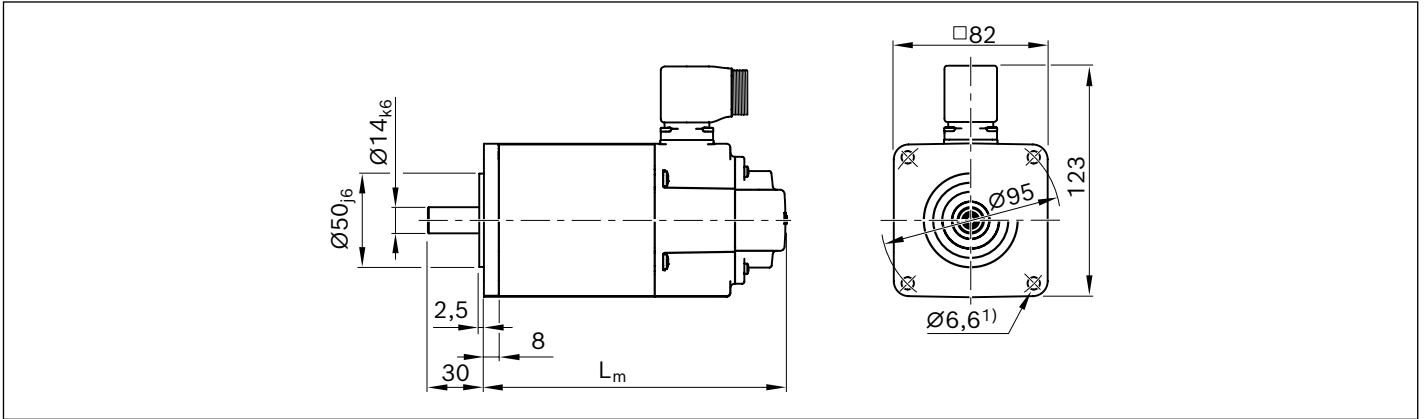

1 4 - 3 0 - 0 5 0 - 2 . 5 - 0 9 5 - M 0 6 - 0 0 8 - 0 8 2

¹⁾ The drill hole $\varnothing 6.6$ mm results in the type designation M06 for the geometry motor code (nominal thread diameter mounting screw M6).

Motor attachment kits for motors according to customer specification can be configured using the online configurator in the eShop. The option “Motor mounting kits according to customer specification” needs to be selected for this.

The motor geometry is entered via the input dialog box. The dimensions can either be entered by being input directly or via a drop-down menu.

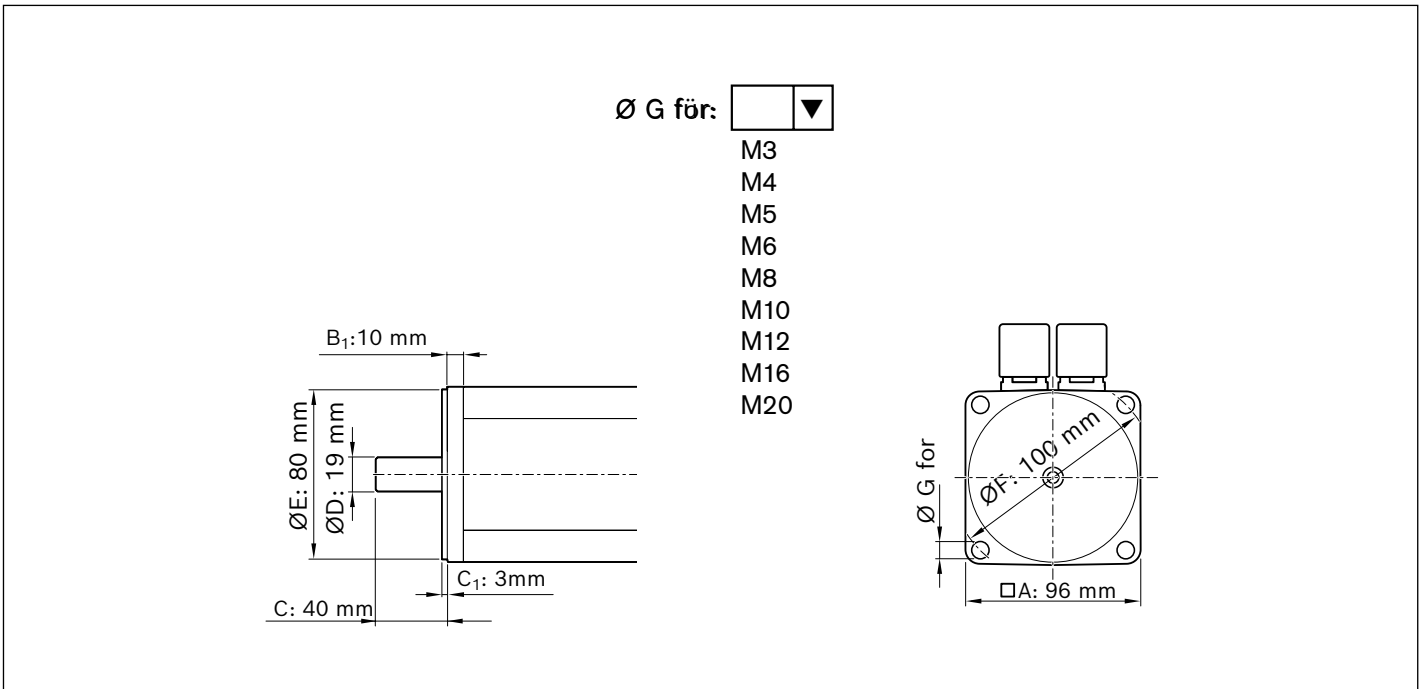

IndraDyn S Synchronous Motor MSM

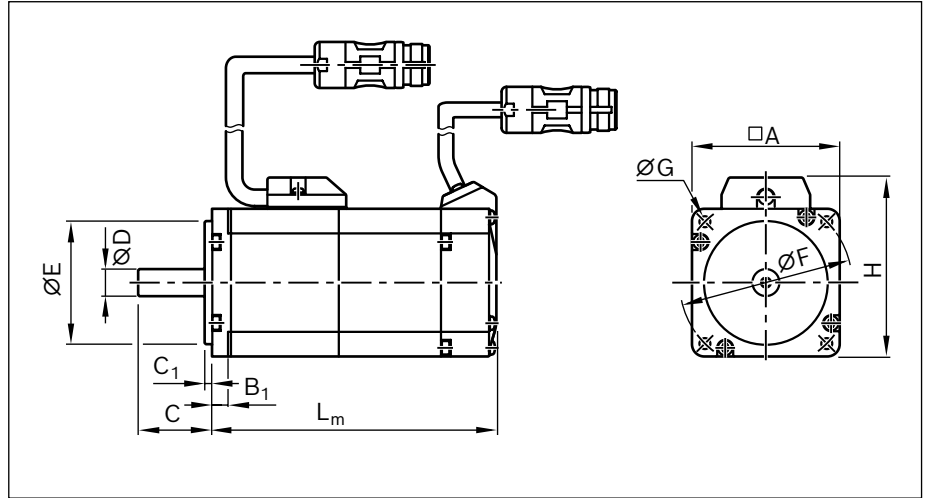

Schematic motor representation

Dimensions / Motor data

Motor code ¹⁾	Dimensions (mm)										
	□ A	B ₁	C	C ₁	Ø D _{h6}	Ø E _{h7}	Ø F	Ø G	H	L _m	
										Brake without	with
MSM 019B-0300	38	6.0	25	3	8	30	45	3.4	51	92.0	122.0
MSM 031B-0300	60	6.5	30	3	11	50	70	4.5	73	79.0	115.5
MSM 031C-0300	60	6.5	30	3	14	50	70	4.5	73	98.5	135.0
MSM 041B-0300	80	6.0	35	3	19	70	90	6.0	93	112.0	149.0

¹⁾ From the "Configuration and Ordering" table.

Version:

- ▶ Plain shaft without shaft seal ring
- ▶ Multiturn absolute encoder M5 (20-bit, absolute encoder functionality only possible with back-up battery)
- ▶ Cooling system: natural convection
- ▶ Protection class IP54 (shaft IP40)
- ▶ With or without brake
- ▶ Metal round plug M17

Note

The motors can be supplied complete with controllers and control units. For further motor types and more information on motors, controllers and control systems, please refer to the Rexroth catalogs on drive technology at www.boschrexroth.com/mediadirectory.

Motor data									Motor connection (Cable)	Brake	Type code	Part number
n_{max} (min^{-1})	M_0 (Nm)	M_{max} (Nm)	M_{br} (Nm)	J_m (kgm^2)	J_{br} (kgm^2)	m_m (kg)	m_{br} (kg)					
5 000	0.32	0.95	0.29	0.0000051	0.0000002	0.47	0.21	2	N	MSM 019B-0300-NN-M5-MH0	R911344211	
									Y	MSM 019B-0300-NN-M5-MH1	R911344212	
5 000	0.64	1.91	1.27	0.0000140	0.0000018	0.82	0.48	2	N	MSM 031B-0300-NN-M5-MH0	R911344213	
									Y	MSM 031B-0300-NN-M5-MH1	R911344214	
5 000	1.30	3.80	1.27	0.0000260	0.0000018	1.20	0.50	2	N	MSM 031C-0300-NN-M5-MH0	R911344215	
									Y	MSM 031C-0300-NN-M5-MH1	R911344216	
4 500	2.40	7.10	2.45	0.0000870	0.0000075	2.30	0.80	2	N	MSM 041B-0300-NN-M5-MH0	R911344217	
									Y	MSM 041B-0300-NN-M5-MH1	R911344218	

IndraDyn S Synchronous Motor MS2N

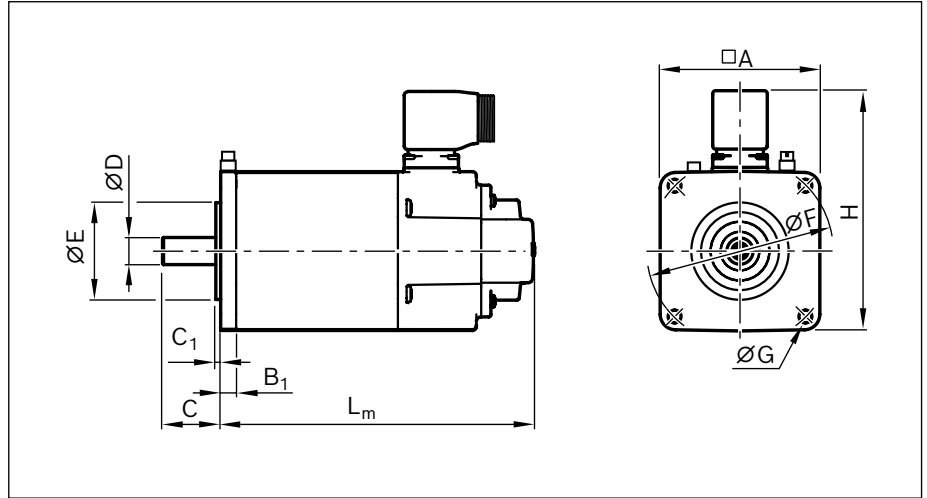

Schematic motor representation

Dimensions / Motor data

Motor code ¹⁾	Dimensions (mm)												
	□ A	B ₁	C	C ₁	Ø D _{k6}	Ø E _{j7}	Ø F	Ø G	Cable		H	Brake	
									2	1		without	with
MS2N03-B0BYN	58	7.5	23	2.5	9	40	63	4.5	84	99	163	192	
MS2N03-D0BYN	58	7.5	23	2.5	11	40	63	4.5	84	99	203	232	
MS2N04-B0BTN	82	8	30	2.5	14	50	95	6.6	108	123	162	194.5	
MS2N04-C0BTN	82	8	30	2,5	14	50	95	6,6	108	123	194	226,5	

¹⁾ From the "Configuration and Ordering" table.

Version

- ▶ Plain shaft without shaft seal ring
- ▶ Multiturn encoder
- ▶ Standard encoder (B) in conjunction with 2-cable connector (HIPERFACE interface)
- ▶ Advanced encoder (B) in conjunction with 1-cable connector (AcuroLink interface)
- ▶ Protection class IP64
- ▶ With or without brake
- ▶ Special ground connection terminal near motor mount (used as needed)

Note

The motors can be supplied complete with controllers and control units. For further motor types and more information on motors, controllers and control systems, please refer to the Rexroth catalogs on drive technology at www.boschrexroth.com/mediadirectory.

Motor data									Motor connection (Cable)	Brake	Type code	Part number
n_{max} (min^{-1})	M_0 (Nm)	M_{max} (Nm)	M_{br} (Nm)	J_m (kgm^2)	J_{br} (kgm^2)	m_m (kg)	m_{br} (kg)					
9 000	0.73	3.46	1.8	0.000023	0.000007	2.0	0.4	2	N	MS2N03-B0BYN-BMDH0-NNNNE-NN	R911384765	
								2	Y	MS2N03-B0BYN-BMDH1-NNNNE-NN	R911384766	
								1	N	MS2N03-B0BYN-CMSH0-NNNNE-NN	R911384767	
								1	Y	MS2N03-B0BYN-CMSH1-NNNNE-NN	R911384769	
9 000	1.15	6.8	1.8	0.000037	0.000007	2.0	0.4	2	N	MS2N03-D0BYN-BMDH0-NNNNE-NN	R911384770	
								2	Y	MS2N03-D0BYN-BMDH1-NNNNE-NN	R911384771	
								1	N	MS2N03-D0BYN-CMSH0-NNNNE-NN	R911384772	
								1	Y	MS2N03-D0BYN-CMSH1-NNNNE-NN	R911384773	
6 000	1.75	5.9	5.0	0.000070	0.000040	2.7	0.7	2	N	MS2N04-B0BTN-BMDH0-NNNNE-NN	R911384525	
								2	Y	MS2N04-B0BTN-BMDH1-NNNNE-NN	R911384526	
								1	N	MS2N04-B0BTN-CMSH0-NNNNE-NN	R911384527	
								1	Y	MS2N04-B0BTN-CMSH1-NNNNE-NN	R911384528	
6 000	2,80	12,0	5,0	0,000110	0,000050	3,7	0,7	2	N	MS2N04-C0BTN-BMDH0-NNNNE-NN	R911384529	
								2	Y	MS2N04-C0BTN-BMDH1-NNNNE-NN	R911384530	
								1	N	MS2N04-C0BTN-CMSH0-NNNNE-NN	R911384531	
								1	Y	MS2N04-C0BTN-CMSH1-NNNNE-NN	R911384532	

Switch Mounting Arrangements

Overview of switching system

Components (unassembled)

- 1 Sensor
- 2 Switching cam
- 3 Mounting duct (aluminum alloy, black anodized)
- 4 Clamping element for mounting duct

Notes for mounting

- ▶ A mounting duct is required to install the sensors.
- ▶ **Mounting side:**
The sensors can be mounted on the left (L) or the right (R).
- ▶ For two-carriage versions:
Sensor actuation with switching cam on drive carriage (motor side).

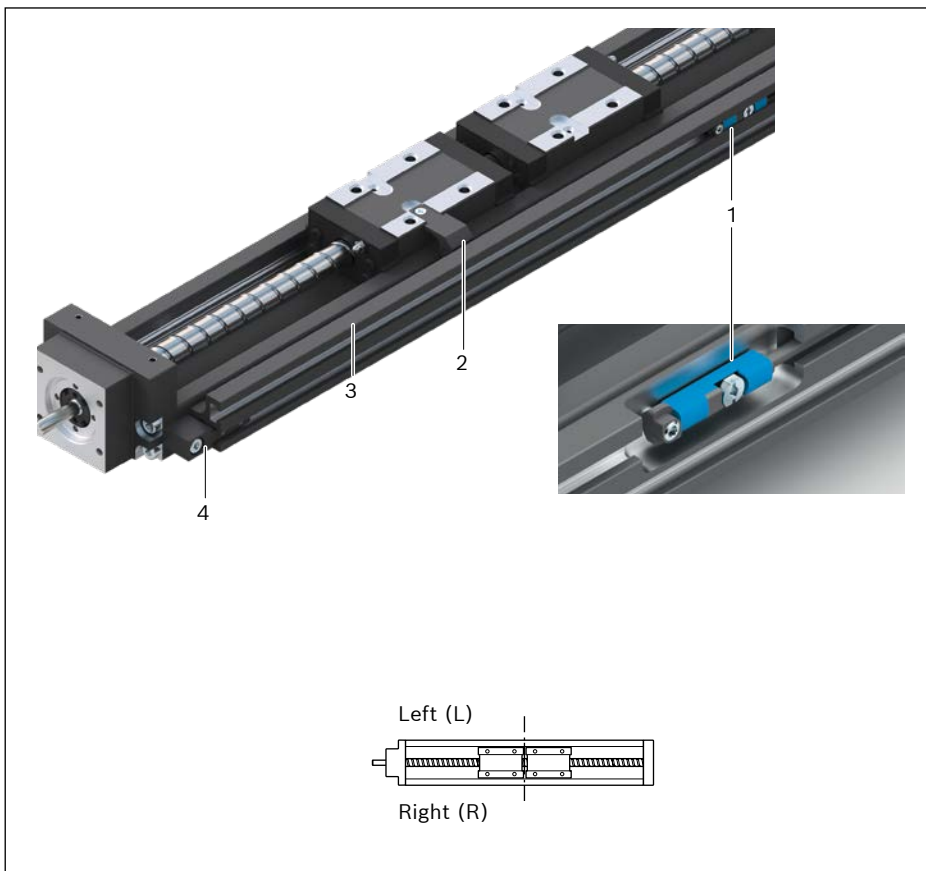

Mounting duct

Function

- For mounting and fastening the sensors
- For housing cables

Notes for mounting

- ▶ The mounting duct is fastened to the end blocks of the Precision Module with clamping elements on the mounting side of the sensors.
- ▶ Fastening materials included in delivery.

Dimensions for mounting duct

PSK	Dimensions (mm)						
	A	B	C	D	N ₁	N ₂	N ₃
050	17.75	8.50	13	24	5.20	5.90	8.20
060							
090							

Installation dimensions for versions without cover or with cover plate

PSK	Dimensions (mm)			
	E	F	G	H
050	17.5	26	14.2	3.5
060	17.5	33	16.2	8.0
090	17.5	46	20.0	14.5

Sensor and attachments

No.	Description	Part numbers
1	Sensor	See chapter "Sensors"
2	Switching cam	
	PSK-050	R14190084
	PSK-060	R14190085
	PSK-090	R14190086
	with Sealing Strip	
	PSK-050	In preparation
	PSK-060	In preparation
	PSK-090	In preparation
3	Mounting duct	R141901101 (L - 12 mm)
4	Clamping element	R141900083
5	Sliding block	R117509008
6	Set screw M4	R343700502

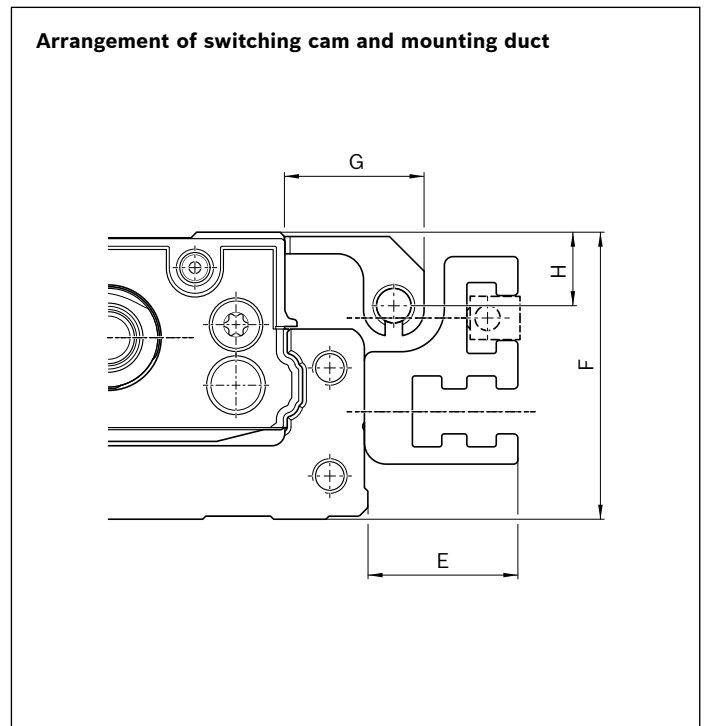
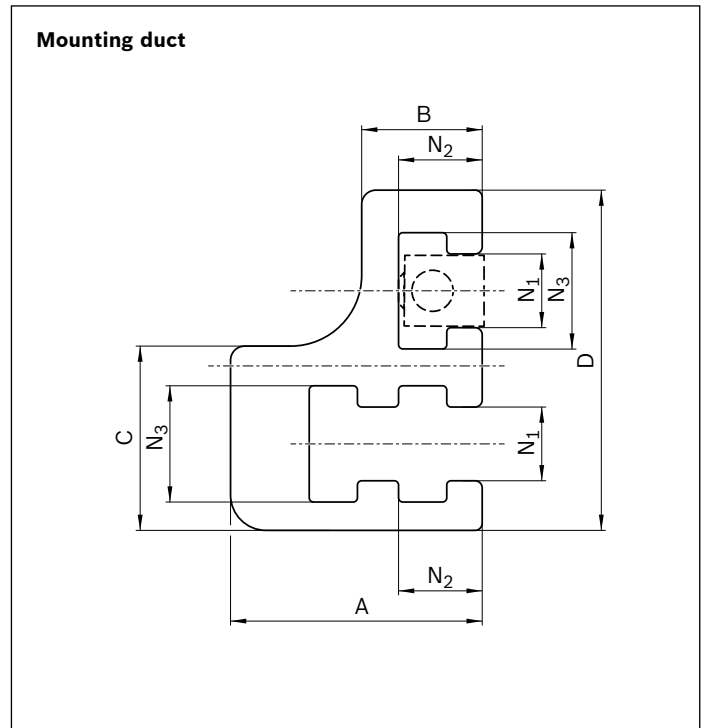

Sensors

Magnetic sensor



Dimensional drawing

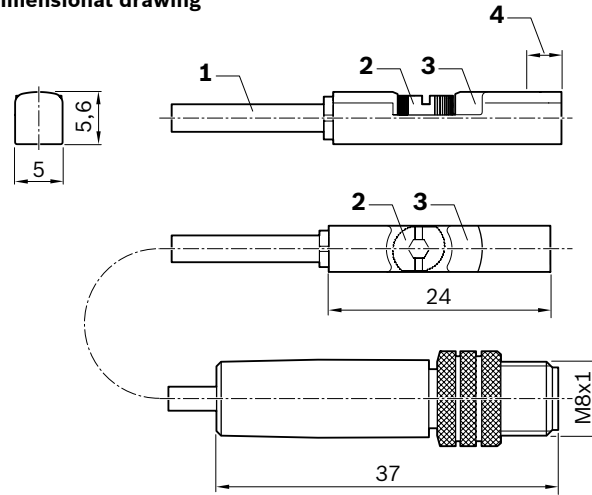

- 1) Connector
- 2) Fixing screw
- 3) LED indicator
- 4) Sensor element position: 2 mm

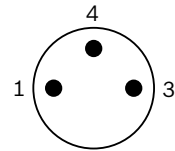

- 1 brown (+)
- 3 blue (-)
- 4 black (signal)

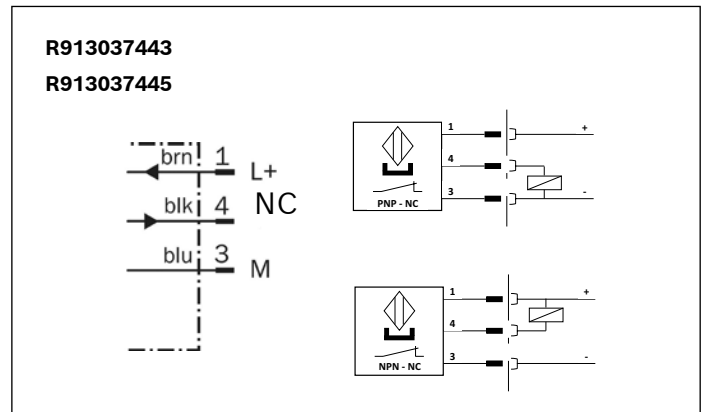
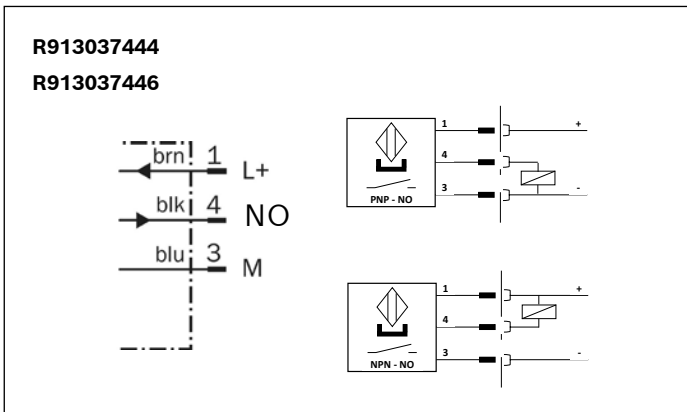

Connection diagram



Material numbers/technical data

Use	Limit switch	Reference switch	Limit switch	Reference switch
Part number	R913037445	R913037444	R913037443	R913037446
Designation	MZT8-03VPO-KRDS14	MZT8-03VPS-KRDS13	MZT8-03VNO-KRDS16	MZT8-03VNS-KRDS15
Functional principle	Magnetic			
Operating voltage	10–30 VDC			
Load current	≤ 200 mA			
Switching function	PNP/NC	PNP/NO	NPN/NC	NPN/NO
Connector type	0.5 m cable and M8x1 connector, 3-pin with knurled screw connection			
Function indicator	✓			
Short-circuit protection	✓			
Polarity protection	✓			
Switch-on suppression	✓			
Switching frequency	3 kHz			
Pulse elongation (off delay)	20 ms			
Max. permissible starting velocity	5 m/s			
Drag chain-capable*	✓			
Twistable*	✓			
Welding spark-resistant*	–			
Wire gauge*	3x0.14 mm ²			
Cable diameter D*	2.9 ±0.15 mm			
Static bending radius*	≥ 5xD			
Dynamic bending radius*	≥ 10xD			
Bending cycles*	> 2 mil.			
Max. permissible travel velocity*	5 m/s			
Max. permissible acceleration*	≤ 5 m/s ²			
Ambient temperature	-30 °C to +80 °C			
Protection class	IP68			
MTTFd (per EN ISO 13849-1)	MTTFd = 2339.0 years			
Certifications and licenses**	  			

* Technical data for connection cable (0.5 m) cast on magnetic sensor only. Available extension cables offer even more performance, e.g. for use in a cable drag chain (see next pages).

** No certificate for import to  the Chinese market required for these products. Document “Sales Information CCC” available on request.

Extensions

Assembled on one end

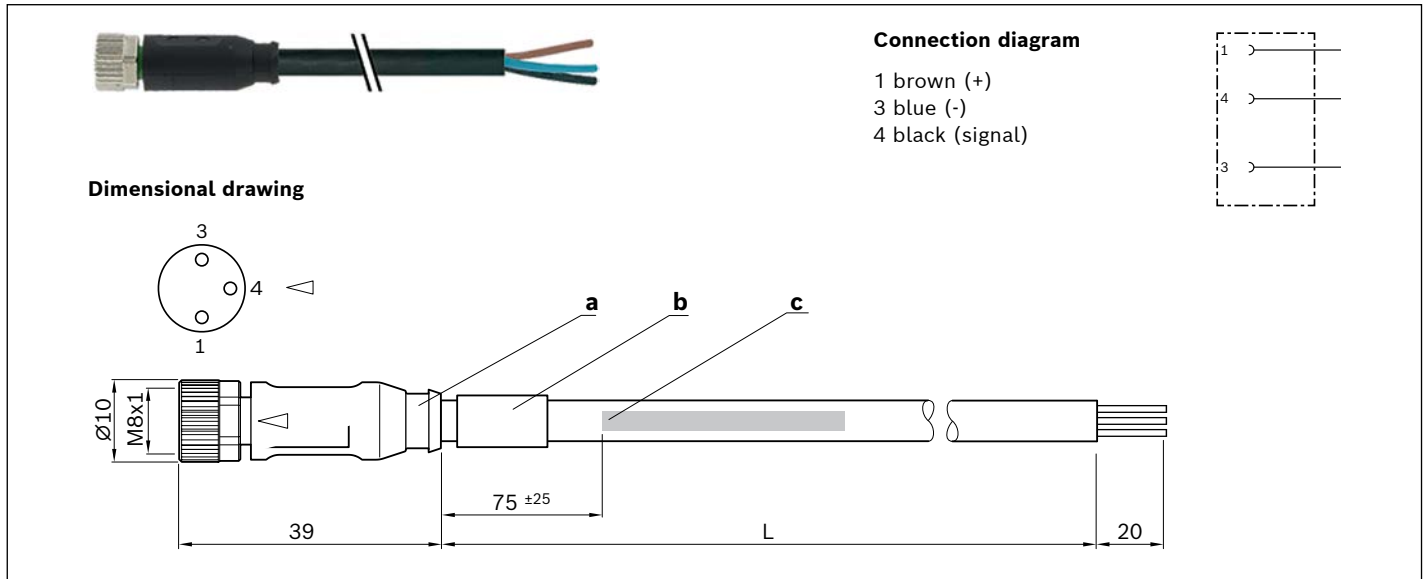

Part numbers

Use	Extension cable		
Part number	R911344602	R911344619	R911344620
Designation	7000-08041-6500500	7000-08041-6501000	7000-08041-6501500
Length (L)	5.0 m	10.0 m	15.0 m
Connector Type 1	Female connector, straight, M8x1, 3-pin		
Connector Type 2	Open end		



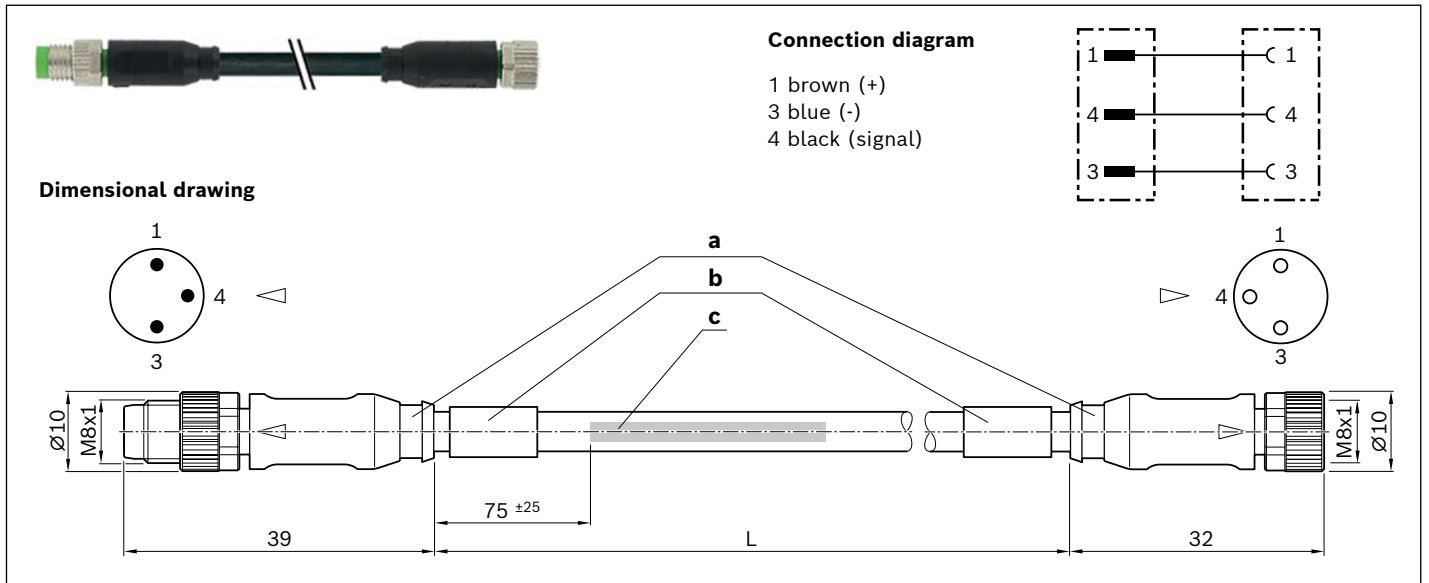

Assembled on both ends



Part numbers

Use	Extension cable				
Part number	R911344621	R911344622	R911344623	R911344624	R911344625
Designation	7000-88001-6500050	7000-88001-6500100	7000-88001-6500200	7000-88001-6500500	7000-88001-6501000
Length (L)	0.5 m	1.0 m	2.0 m	5.0	10.0
Connector Type 1	Female connector, straight, M8x1, 3-pin				
Connector Type 2	Male connector, straight, M8x1, 3-pin				

Technical data for extensions assembled on one and both ends



Function indicator	-
Operating voltage indicator	-
Operating voltage	10–30 VDC
Cable type	PUR black
Drag chain-capable	✓
Twistable	✓
Welding spark-resistant	✓
Wire gauge	3x0.25 mm ²
Cable diameter D	4.1 ± 0.2 mm
Static bending radius	≥ 5xD
Dynamic bending radius	≥ 10xD
Bending cycles	> 10 mil.
Max. permissible travel velocity	3.3 m/s for 5 m travel distance (typ.), up to 5 m/s for 0.9 m travel distance
Max. permissible acceleration	≤ 30 m/s ²
Ambient temperature (fixed ext.)	-40 °C to +85 °C
Ambient temperature (flexible ext.)	-25 °C to +85 °C
Protection class	IP68
Certifications and licenses	    

- a) Contour for conduit pipe with inner diameter of 6.5 mm
- b) Cable grommet
- c) Cable printing per printing specification

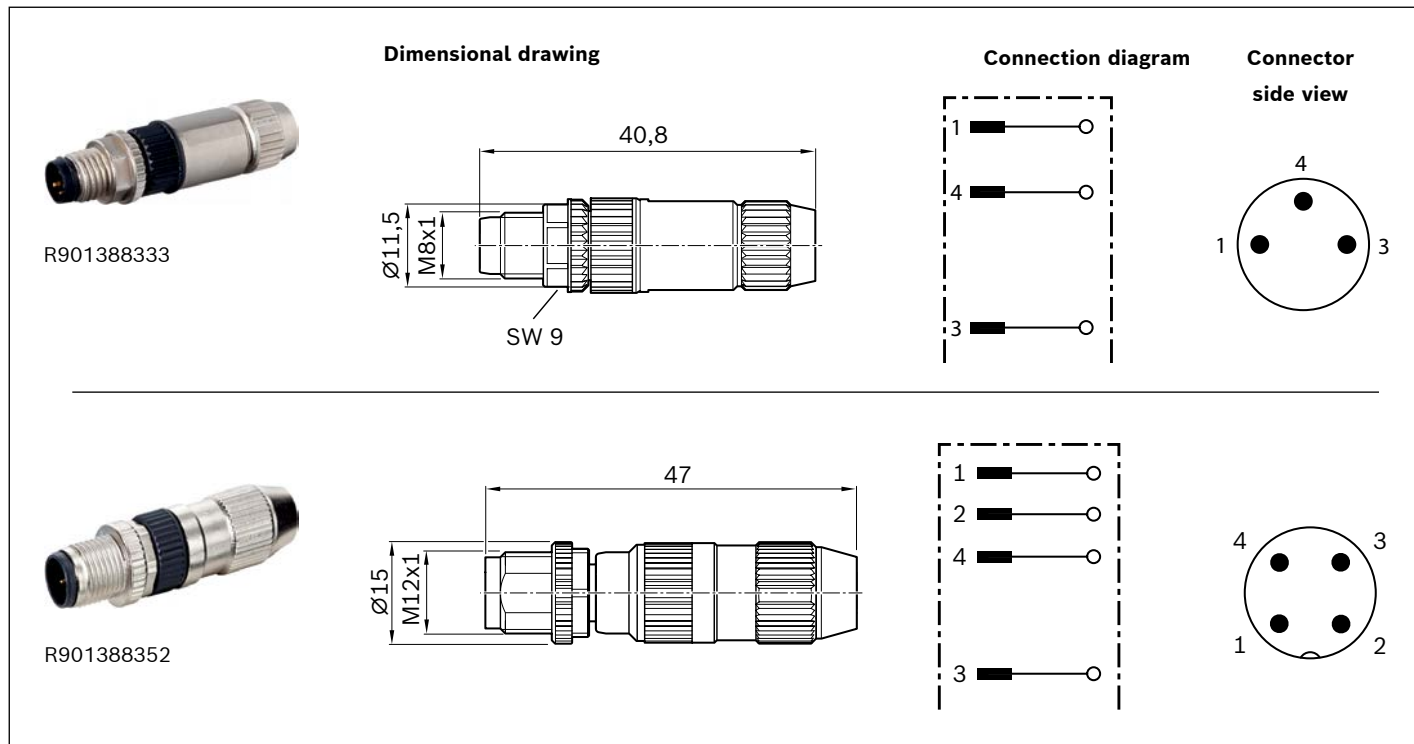
Male Connector



Material numbers/technical data

Use	Male connector, single	
Part number	R901388333	R901388352
Designation	7000-08331-0000000	7000-12491-0000000
Version	Straight	
Operating current per contact	max. 4 A	
Operating voltage	max. 32 V AC/DC	
Connector type	Male connector, straight, M8x1, 3-pin Insulation displacement, self-locking screw thread	Male connector, straight, M12x1, 4-pin Insulation displacement, self-locking screw thread
Function indicator	-	
Operating voltage indicator	-	
Connector cross-section	0.14...0.34 mm ²	
Ambient temperature	-25 °C to +85 °C	
Protection class	IP67 (inserted and locked)	
Certifications and licenses	  	



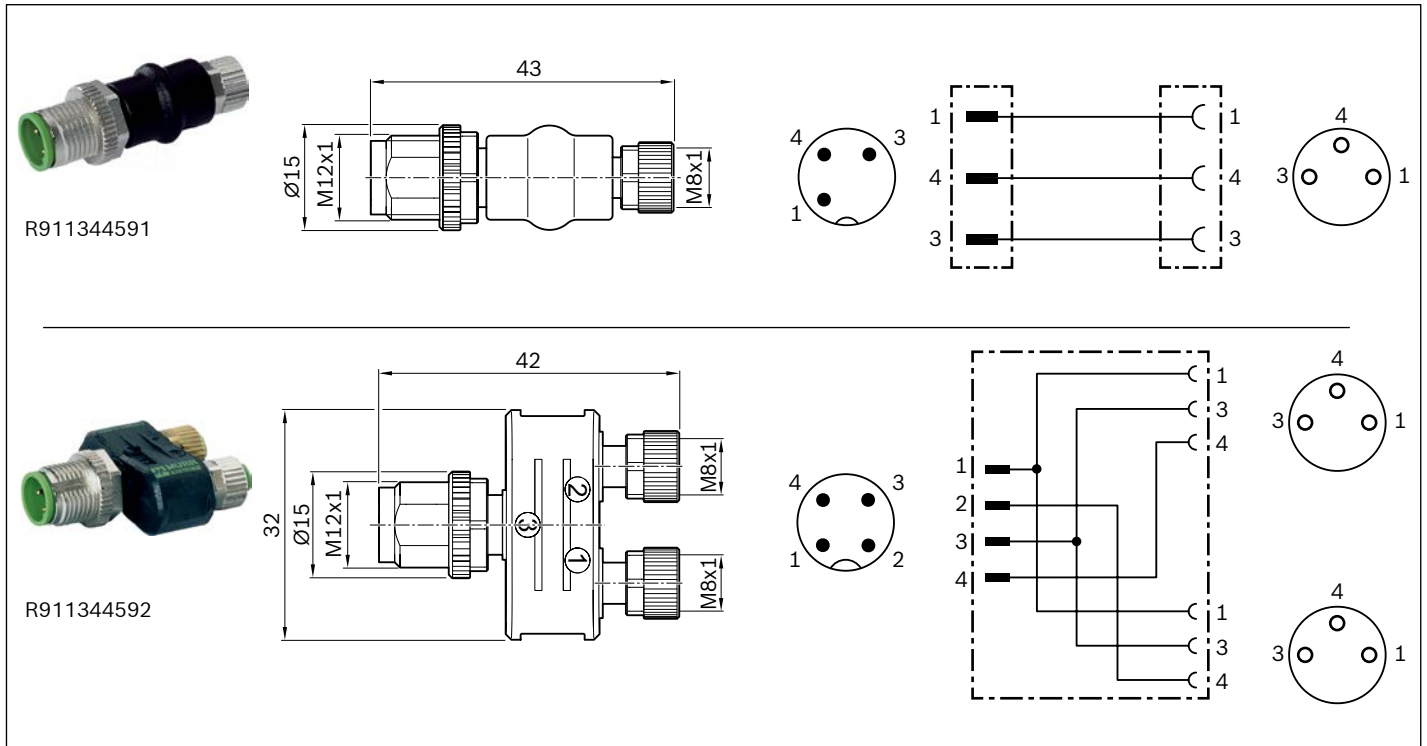

Dimensional drawing

Connection diagram

Adapter





Material numbers/technical data

Use	Adapter	
Part number	R911344591	R911344592
Designation	7000-42201-0000000	7000-41211-0000000
Version	Straight	
Operating current per contact	max. 4 A	
Operating voltage	max. 32 V AC/DC	
Connector Type 1	Female connector, straight, M8x1, 3-pin Self-locking screw thread	2x female connector, straight, M8x1, 3-pin Self-locking screw thread
Connector Type 2	Male connector, straight, M12x1, 3-pin Self-locking screw thread	Male connector, straight, M12x1, 4-pin Self-locking screw thread
Function indicator	-	
Operating voltage indicator	-	
Connector cross-section	-	
Ambient temperature	-25 °C to +85 °C	
Protection class	IP67 (inserted and locked)	
Certifications and licenses		  

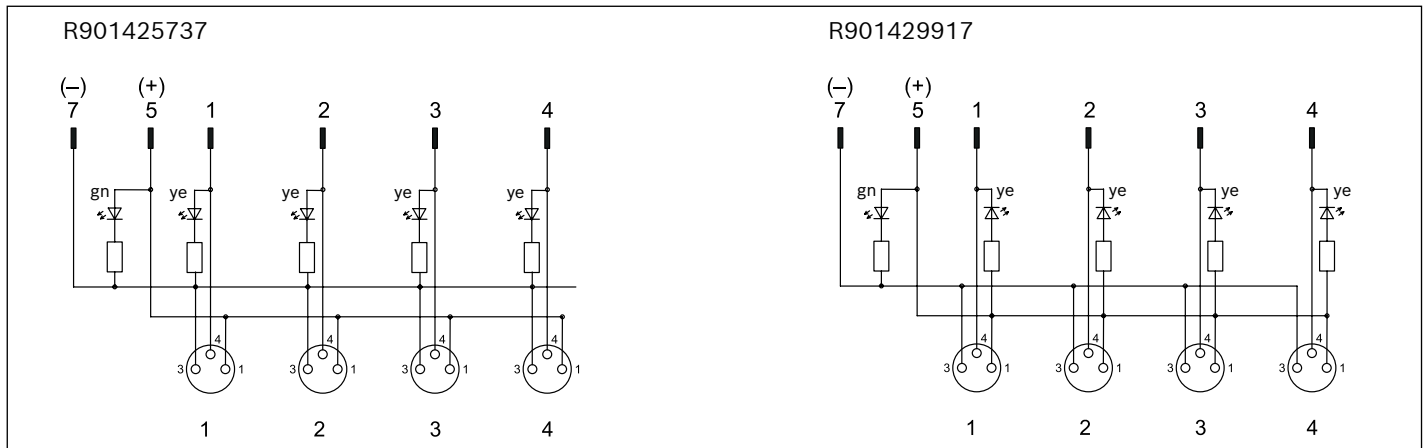
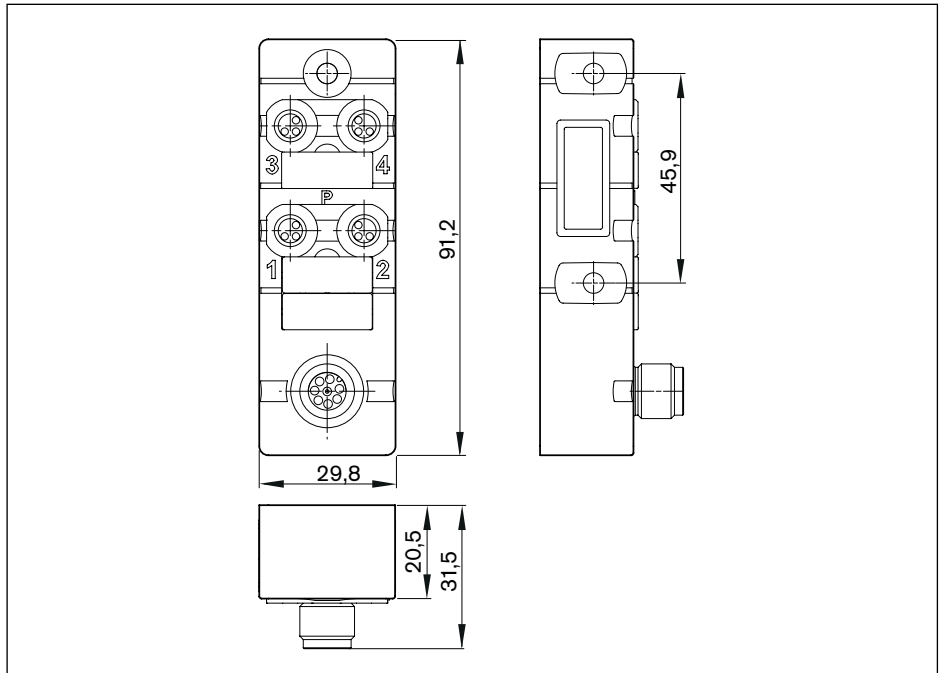
Passive Distributor



Material numbers/technical data

Use	Passive distributor		
Part number	R901425737	R901429917	R911344592
Designation	8000-84070-0000000	8000-84071-0000000	
Version	Straight, for 1-4 sensors		
Operating current per contact	max. 2 A		
Operating voltage	24 VDC		
Switching logic	PNP	NPN	
Connector Type 1	4x female connector, straight, M8x1, 3-pin Self-locking screw thread		
Connector Type 2	Male connector, straight, M12x1, 8-pin Self-locking screw thread		
Function indicator	✓		
Operating voltage indicator	✓		
Connector cross-section	-		
Ambient temperature	-20 °C to +70 °C		
Protection class	IP67 (inserted and locked)		
Certifications and licenses	  		

For technical data and dimensional drawings, see adapter

Accessories for passive distributors

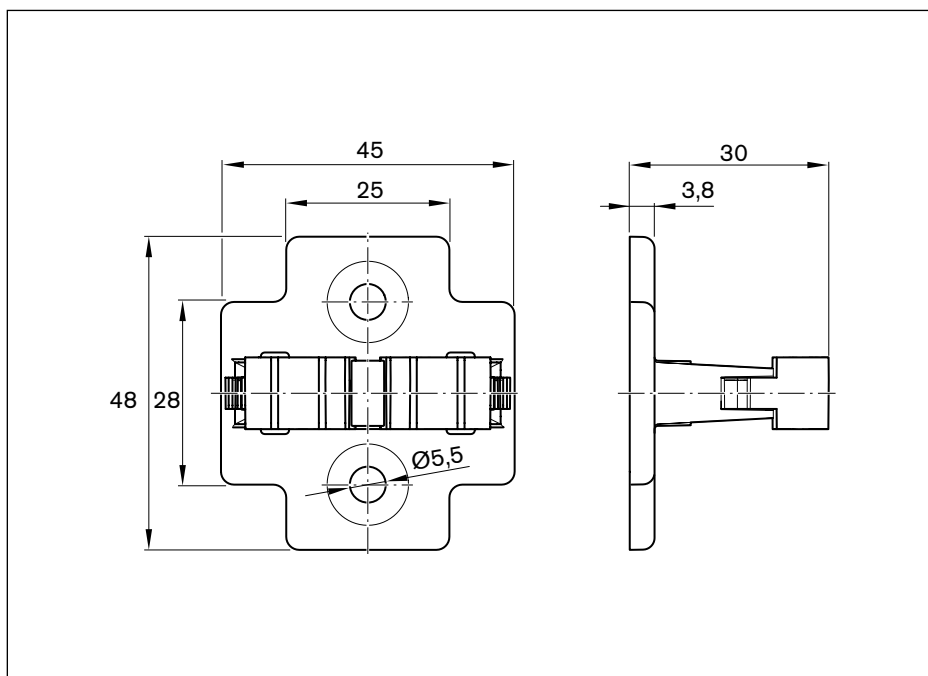

Material numbers/technical data



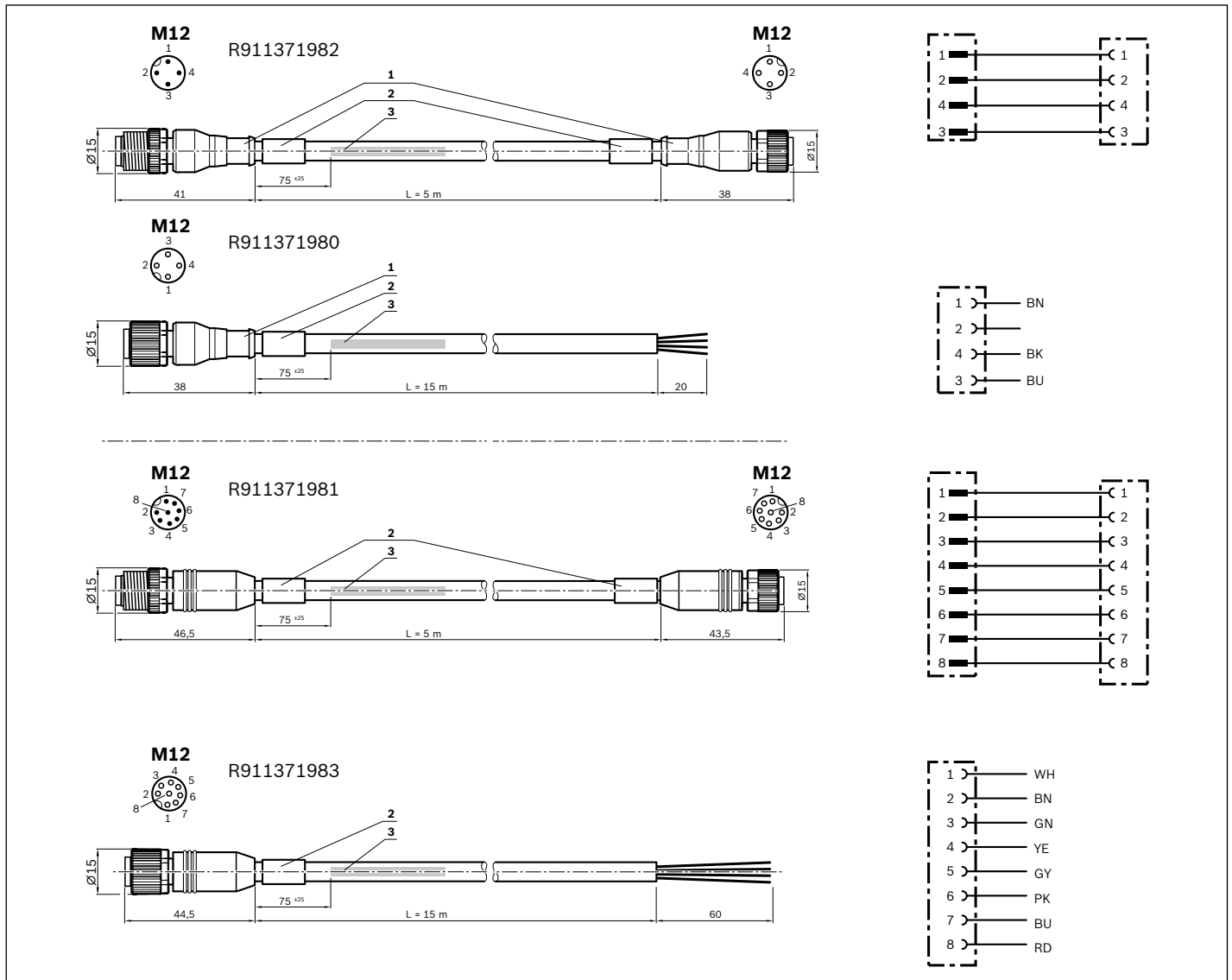
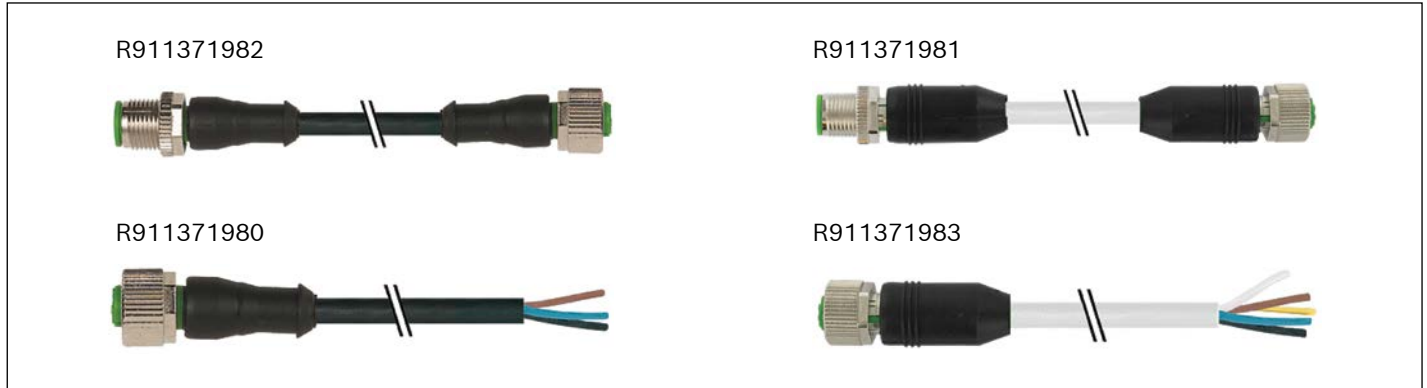

Use	For passive distributor R911344592	For passive distributor R901425737 / R901429917
Retainer plate	R913047341	-
Designation	7000-99061-0000000	-
Set	1 unit	-
Screw plug	-	R913047322
Designation	-	3858627
Set	-	10 units

Extensions for Passive Distributors



- 1) Contour for conduit pipe with inner diameter of 10
- 2) Cable grommet
- 3) Cable print per ordering specification 7000-08001

Material numbers/technical data

Use	Extension cable for passive distributor R911344592		Extension cable for passive distributor R901425737 / R901429917	
Part number	R911371982	R911371980	R911371981	R911371983
Designation	7000-40021-6540500	7000-12221-6541500	7000-48001-3770500	7000-17041-3771500
Length	5.0 m	15.0 m	5.0 m	15.0 m
Connector Type 1	Female connector, straight, M12x1, 4-pin		Female connector, straight, M12x1, 8-pin	
Connector Type 2	Male connector, straight, M12x1, 4-pin	Open end	Male connector, straight, M12x1, 8-pin	Open end
Function indicator	-			
Operating voltage indicator	-			
Cable type	PUR black		PUR gray	
Operating voltage	30 V AC/DC			
Operating current per contact	max. 4 A per contact		max. 2 A per contact	
Drag chain-capable	✓			
Twistable	✓			
Welding spark-resistant	✓			
Wire gauge	4x0.34 mm		8x0.34 mm	
Cable diameter D	4.7 +/- 0.2 mm		6.2 +/- 0.3 mm	
Static bending radius	≥ 5 x D			
Dynamic bending radius	≥ 10 x D			
Bending cycles	> 10 mil.			
Max. permissible travel velocity	3.3 m/s for 5 m travel distance (typ.), up to 5 m/s for 0.9 m travel distance			
Max. permissible acceleration	≤ 30 m/s			
Ambient temperature (fixed ext.)	-40 °C to +80 °C (90° max. 10,000 h)			
Ambient temperature (flexible ext.)	-25 °C to +80 °C (90° max. 10,000 h)			
Protection class	IP67 (inserted and locked)			
Certifications and licenses	    			

Example Combinations

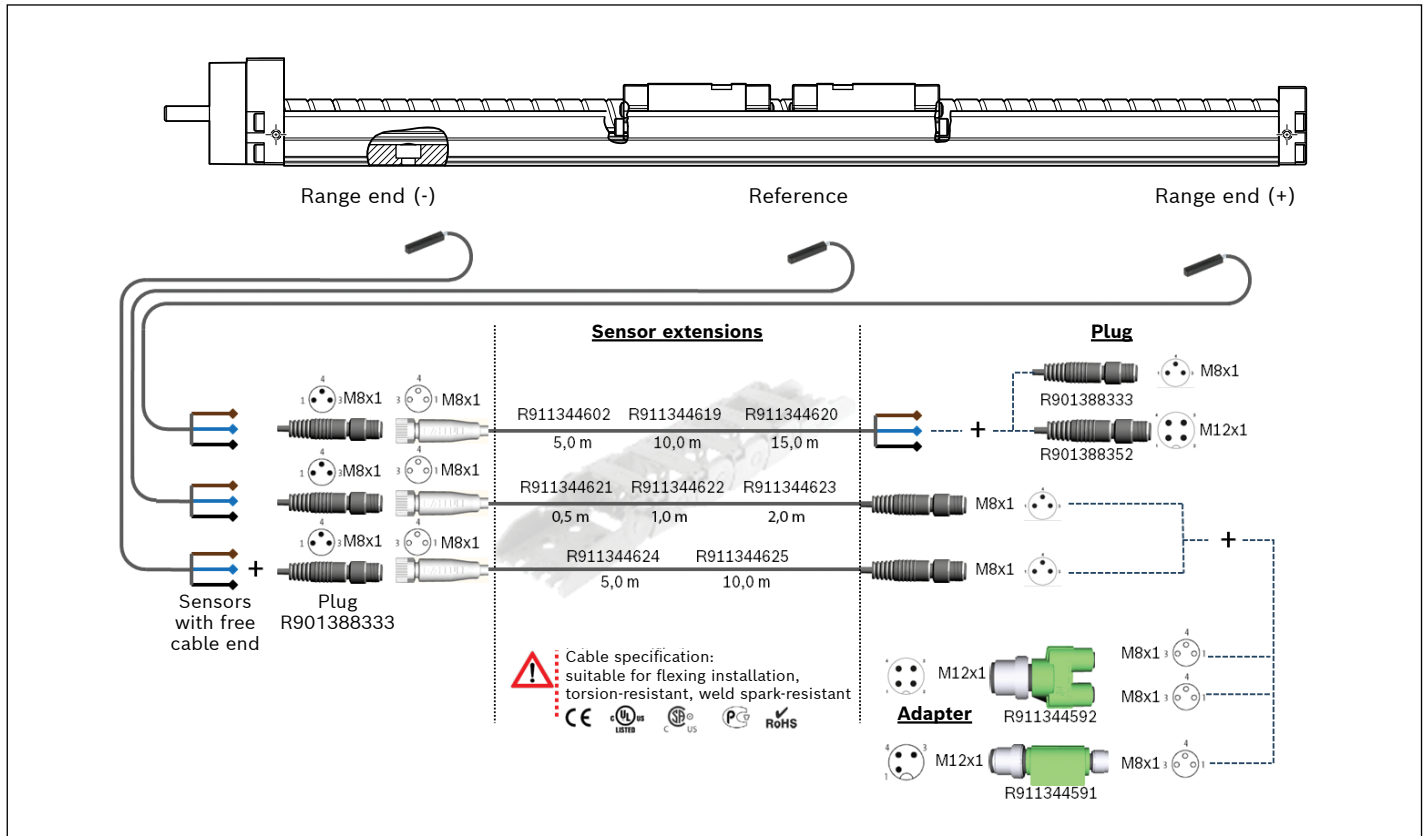

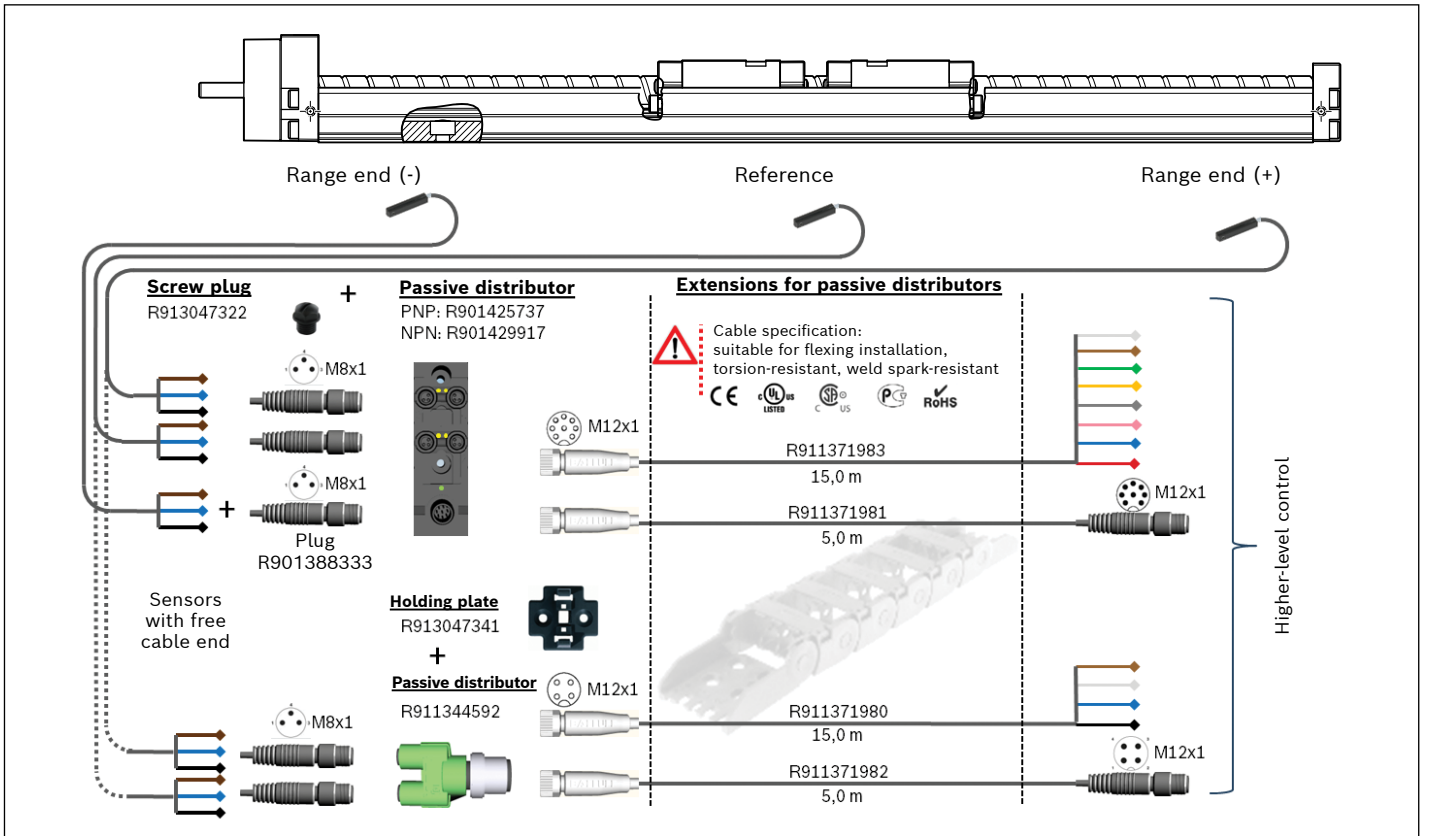

SERVICE AND INFORMATION

Operating Conditions

Normal operating conditions

Ambient temperature with Rexroth servo motor	0 °C ... 40 °C, performance loss after 40 °C
Mechanical group ambient temperature (must not fall below dew point)	-10 °C ... 60 °C
Travel distance $s_{\min}^{1)}$	See "Technical Data" table
Contamination	Not permitted

1) Min. travel distance required to guarantee lubricant distribution.

Notes

For more information on proper use and safety, see "Safety Instructions for Linear Motion System R320103152".

For information on mounting/start-up, see manual for Precision Modules R320103187.

PDF files of these documents can be found online at www.boschrexroth.com/mediadirectory

Parameterization (Start-up)

In addition to references for Linear Motion System production, the name plate contains technical parameters for start-up.

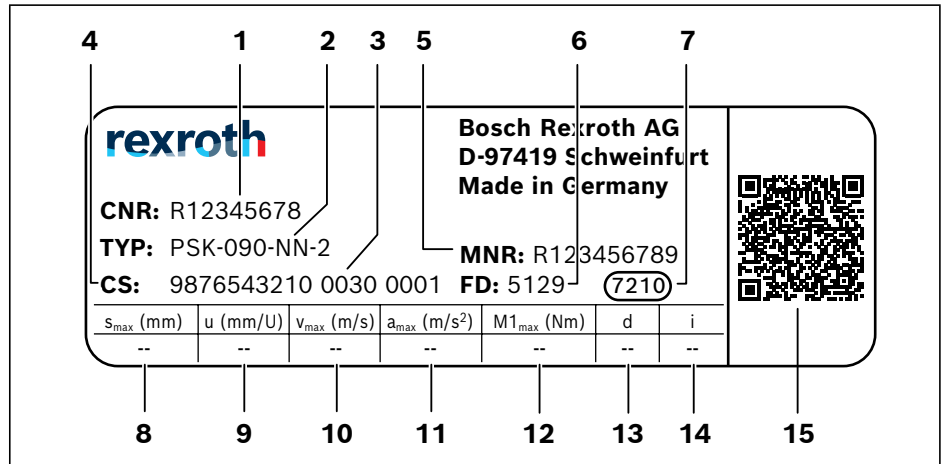

1	CNR	Customer's part number
2	TYP	Short product name
3	090	Size
4	CS	Customer information
5	MNR	Part number
6	FD	Manufacturing date
7	7210	Manufacturing location
8	s_{max}	Max. travel range
9	u	Lead constants without motor attachment
10	v_{max}	Max. velocity
11	a_{max}	Max. acceleration
12	$M1_{max}$	Max. drive torque at motor journal
13	d	Direction of motor rotation to move in positive (+) direction CW = clockwise CCW = counterclockwise

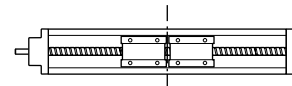
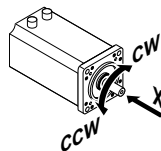

14	i	Gear ratio
15		QR code

Mounting

- ▶ **Do not mount or support the Precision Module by the end blocks. The frame is the main load-bearing part.**

Precision Modules can be mounted using screws through drill holes in the frame. When mounting Precision Modules, please note the maximum tightening torques listed in the table.

The reference edge on the frame facilitates alignment of the Precision Module. Remove any cover plate before mounting the module.

For installation dimensions, see the relevant dimension drawings.

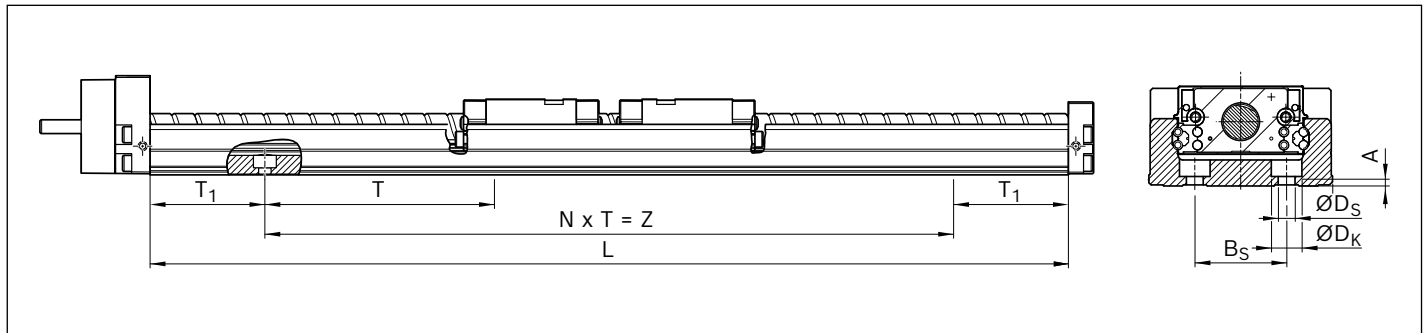
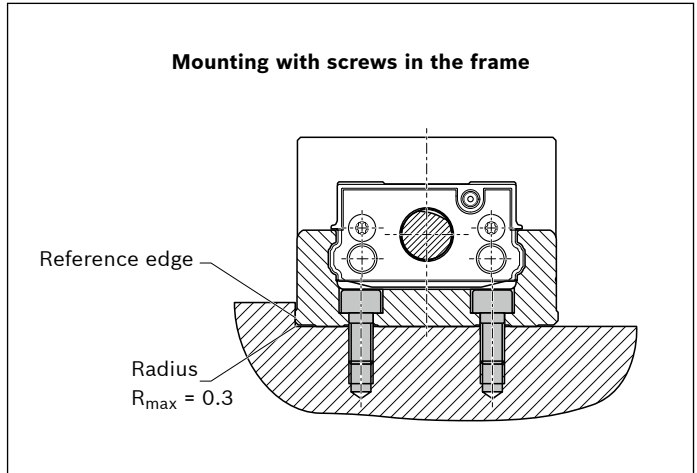

PSK-050

Dimensions (mm)									
L	A	BS	ØD _K	ØD _S	T	T ₁	Z	N	
100	2,5	25	8	4,5	80	10	80	1	M4
150						35	80	1	
200						20	160	2	
250						45	160	2	
300						30	240	3	
350						15	320	4	
400						40	320	4	

PSK-060

Dimensions (mm)									
L	A	BS	ØD _K	ØD _S	T	T ₁	Z	N	
150	3,1	30	10	5,5	100	25	100	1	M5
200						50	100	1	
300						50	200	2	
400						50	300	3	
500						50	400	4	
600						50	500	5	
700						50	600	6	

PSK-090

Dimensions (mm)									
L	A	BS	ØD _K	ØD _S	T	T ₁	Z	N	
340	4,5	46	11	6,5	100	70	200	2	M6
440							300	3	
540							400	4	
640							500	5	
740							600	6	
840							700	7	
940							800	8	

Lubrication and Maintenance

General notes

The lubrication system on Precision Modules has been designed for grease lubricants (grease gun). The lube fitting (ball-type lube nipple) supplies lubricant to both the guideway and the Ball Screw Assembly. If the module has two carriages, both of these must be lubricated.

Replacing the lube fitting with a connector reduces the maximum travel distance per lube fitting due to the additional interference contour.

Reduction of maximum travel distance

PSK	Dimensions (mm)	
	Straight	Elbow connection
050	-8.0	-11.0
060	-7.5	-10.5
090	-6.8	-9.8

Funnel-type lube nipple (PSK050)

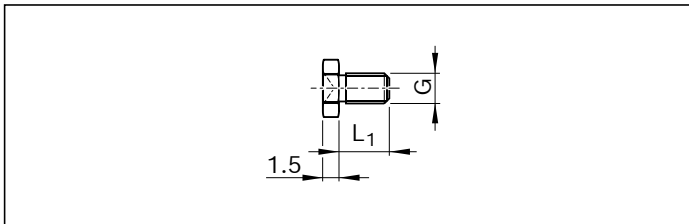

Part number	Dimensions (mm)		Mass (g)
	G	L ₁	
R3417 069 09	M4	5	0.4

Straight connectors¹⁾ for plastic tubes and metal pipes

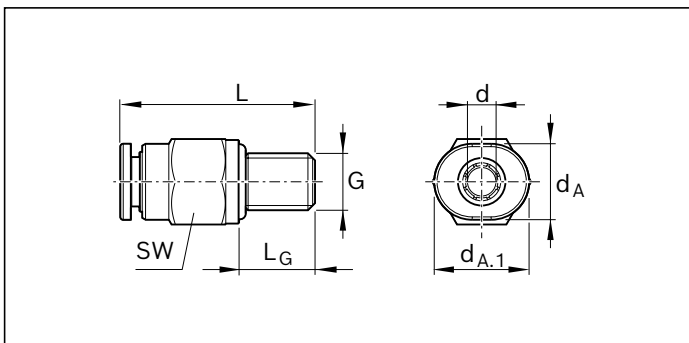

Part number	Dimensions (mm)							Mass (g)
	d _A	d _{A.1}	d _{±0.1}	G	L	L _G	SW	
R3417 071 09	6.0	7	3	M4	16	5	6 ²⁾	1.4

1) Max. lubrication pressure: 30 bar (when using a grease gun, pump slowly)

2) Max. tightening torque $M_A = 0.5 \text{ Nm}$

PSK without cover

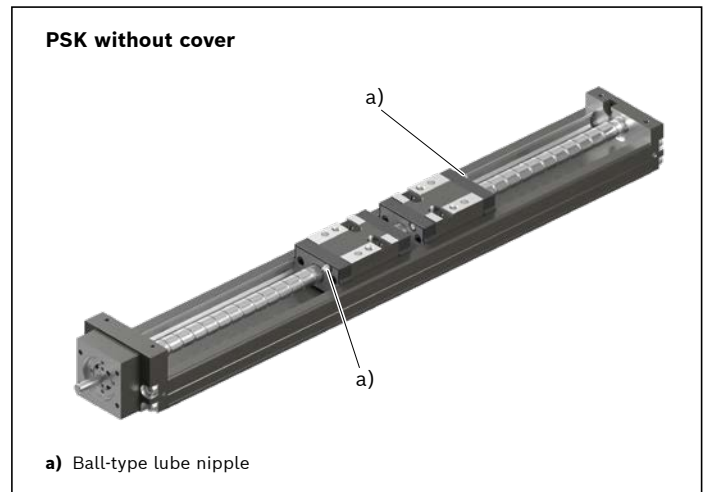

a) Ball-type lube nipple

Ball-type lube nipple (PSK060 and PSK090)

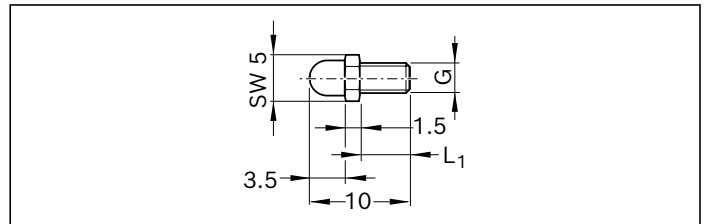

Part number	Dimensions (mm)		Mass (g)
	G	L ₁	
R3417 006 01	M4	5	0.5

Elbow plug-in connections rotatable¹⁾ for plastic tubes and metal pipes

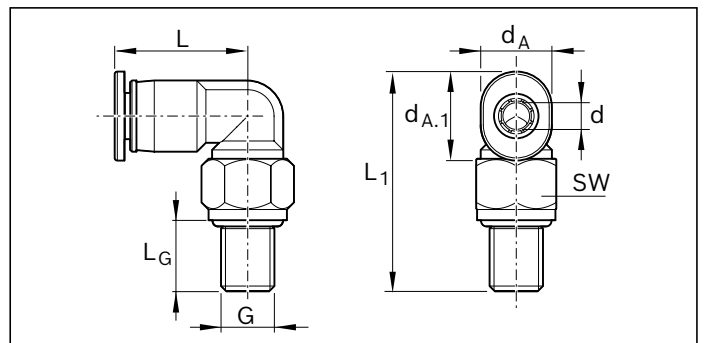

Part number	Dimensions (mm)							Mass (g)
	d _A	d _{A.1}	d _{±0.1}	G	L	L _G	SW	
R3417 071 09	6.0	7	3	M4	11	5	6 ²⁾	1.7

Lubricant

Lubrication types	LSS		LPG		
Basic lubrication	Castrol Tribol GR 100-2 PD	Castrol Tribol GR 100-00 PD	Preserved, basic lubrication required		
Size	PSK-050: 8x5 PSK-060: 12x5; 12x10 PSK-090	PSK-050: 8x1; 8x2 PSK-060: 12x2	PSK-050: 8x2.5; 8x5 PSK-060: 12x5; 12x10 PSK-090	PSK-050: 8x1; 8x2 PSK-060: 12x2	
Consistency class	NLGI 2 (DIN 51818)	NLGI 00 (DIN51818)	–		
Identification	KP2K-20 (DIN 51825)	GP00K-20 (DIN 51826)	–		
Lubrication using a grease gun	Yes	Yes	Yes		
Prepared for connection to central lubrication systems	–	–	–		
Lubricant recommendation	Castrol Tribol GR 100-2 PD (grease) (NLGI2 DIN 51818)	Castrol Tribol GR 100-00 PD (fluid grease) (NLGI00 DIN51818)	Castrol Tribol GR 100-2 PD (grease) (NLGI2 DIN 51818)	Castrol Tribol GR 100-00 PD (fluid grease) (NLGI00 DIN51818)	
Characteristics	<ul style="list-style-type: none"> • Good water resistance • Corrosion protection • Temperature range: –20 to +80 °C 		<ul style="list-style-type: none"> • Good water resistance • Corrosion protection • Temperature range: –20 to +80 °C 		
Material number USA (Tribol 100-2 / 100-00)	R3416 031 00 (cartridge 400 g)	R0419 090 03 (5 cc syringe)	R3416 031 00 (cartridge 400 g)	R0419 090 03 (5 cc syringe)	
Material number EU (Dynalub 510 / 520)	R3416 037 00 (cartridge 400 g)	R3416 035 00 (hobcock 25 kg)	R3416 042 00 (bucket 5 kg)	R3416 037 00 (cartridge 400 g)	R3416 035 00 (hobcock 25 kg)
Alternative greases EU	<ul style="list-style-type: none"> • Dynalub 510 • Elkalub GLS 135/N2 	<ul style="list-style-type: none"> • Dynalub 520 • Elkalub GLS 135/N00 	<ul style="list-style-type: none"> • Tribol GR 100-2 PD, Elkalub GLS 135/N2 • Tribol GR 100-00 PD, Elkalub GLS 135/N00 • Dynalub 520 	<ul style="list-style-type: none"> • Tribol GR 100-00 PD • Elkalub GLS 135/N00 	
Alternative greases with H1 certification	Chevron FM ALC EP 2 (PSK -060 / PSK -090)	–	<ul style="list-style-type: none"> • Berulub FG H2 SL ; VP 874 • Cassida Grease EPS2 • Chevron FM ALC EP 2 	<ul style="list-style-type: none"> • Berulub FB 34-00 • Elkalub GLS 367/N00 	

► Notes on lubrication ⇒ instructions

LCF		LSC	
PSK-050, -060, -090		Castrol Tribol GR 215-2 PD	Castrol Tribol GR 100-00 PD
PSK-050, -060, -090		PSK-050: 8x2.5; 8x5 PSK-060: 12x5; 12x10 PSK-090	PSK-050: 8x1; 8x2 PSK-060: 12x2
NLGI 00 (DIN51818)		NLGI 2 (DIN51818)	NLGI 00 (DIN51818)
GP00K-20 (DIN 51826)		KP2K-20 (DIN 51825)	GP00K-20 (DIN 51826)
Yes		Yes	
<ul style="list-style-type: none"> • Only with single-line distributor system via a piston distributor • Smallest permissible piston distributor size: 0,2 cm³ 		—	
Tribol GR 100-00 PD or Dynalub 520 (fluid grease) (NLGI00 DIN51818)		Tribol GR 100-2 PD (NLGI2 DIN 51818)	Tribol GR 100-00 PD (NLGI2 DIN 51818)
<ul style="list-style-type: none"> • Good water resistance • Corrosion protection • Temperature range: -20 to +80 °C 		<ul style="list-style-type: none"> • Good water resistance • Corrosion protection • Temperature range: : -20 °C to +80 °C 	
—		—	
R3416 043 00 (cartridge 400 g)	R3416 042 00 (bucket 5 kg)	R3416 031 00 (cartridge 400 g)	R3416 032 00 (bucket 5 kg)
<ul style="list-style-type: none"> • Castrol Longtime PD00 • Elkalub GLS 135/N0 		<ul style="list-style-type: none"> • Elkalub GLS 135/N2 • Dynalub 510 	<ul style="list-style-type: none"> • Elkalub GLS 135/N00 • Dynalub 520
—		—	

Documentation

Standard report Option 001

The standard report serves to confirm that the checks listed in the report have been carried out and that the measured values lie within the permissible tolerances.

Checks listed in the standard report:

- Functional checks of mechanical components
- Functional checks of electrical components
- Design is in accordance with order confirmation

Friction moment measurement of complete system

Option 002

The friction moment M_{Rs} is measured along the entire travel distance.

- 1) Advance
- 2) Return

Example graphs

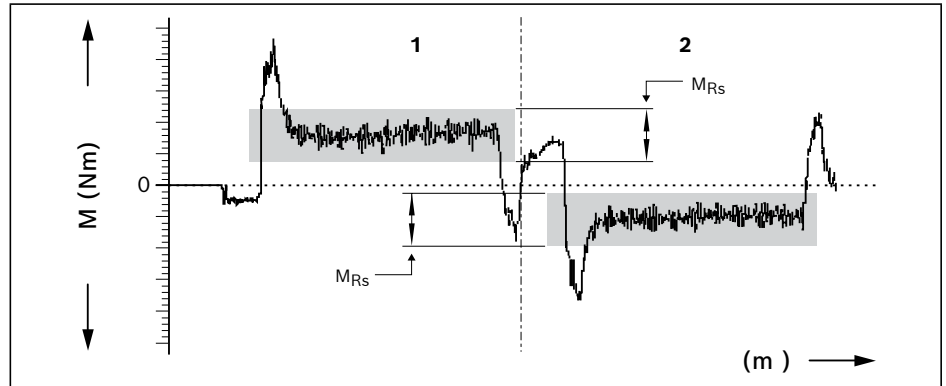

Screw Drive lead deviation Option 003

A measurement report of the deviation d over the measured travel s (see figure) is provided in table form in addition to the graph.

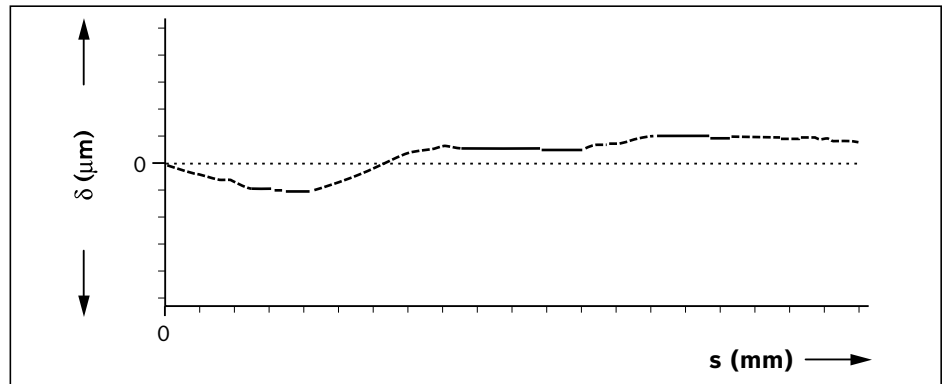

Running accuracy Option 004

Yawing

Yawing is angular deviation about the vertical axis. This angular deviation is converted to a linear deviation d in mm on the basis of a Standard and is plotted on the graph. The base length is given in the graph.

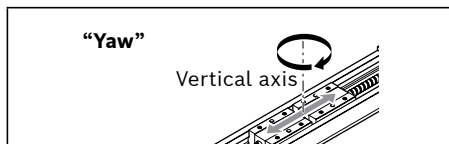
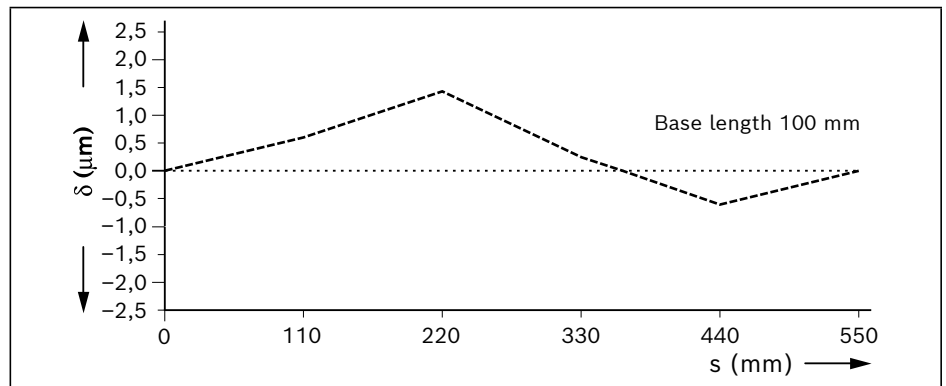

Several measuring points are passed during the total travel. The yawing and pitching deviations are measured at these points. Note The measurements are taken with the module screwed down and assuming an ideally flat mounting base surface.

Running accuracy Option 004 (cont'd)

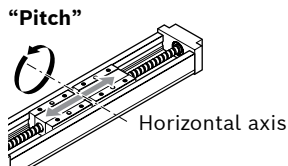

Pitching

Pitching means angular deviation about the horizontal axis.

This angular deviation is converted to a linear deviation δ in μm on the basis of a base length and is plotted on the graph.

Example graphs

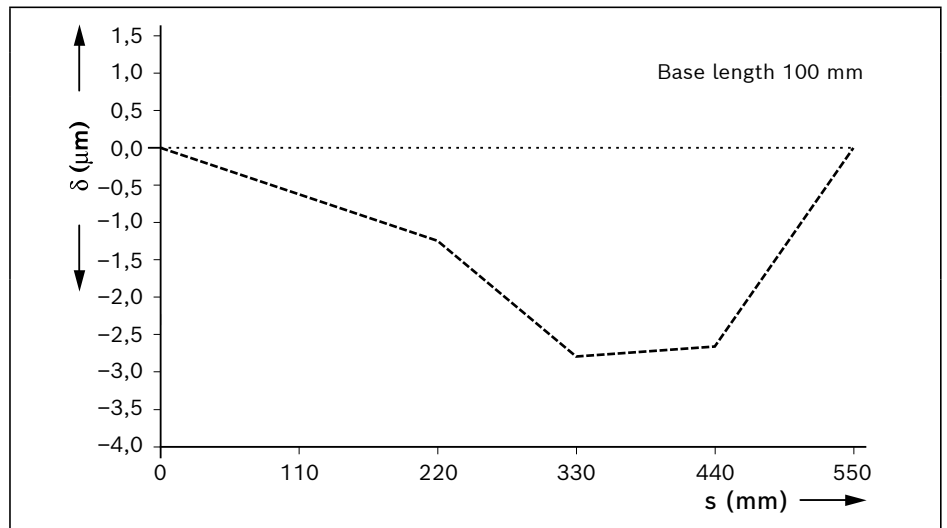

Positioning accuracy per VDI/DGQ 3441 Option 005

Measurement points are selected at irregular intervals along the travel range. This enables even periodical deviations δ in μm to be detected during positioning.

Each measurement point is approached several times from both sides.

This gives the following parameters.

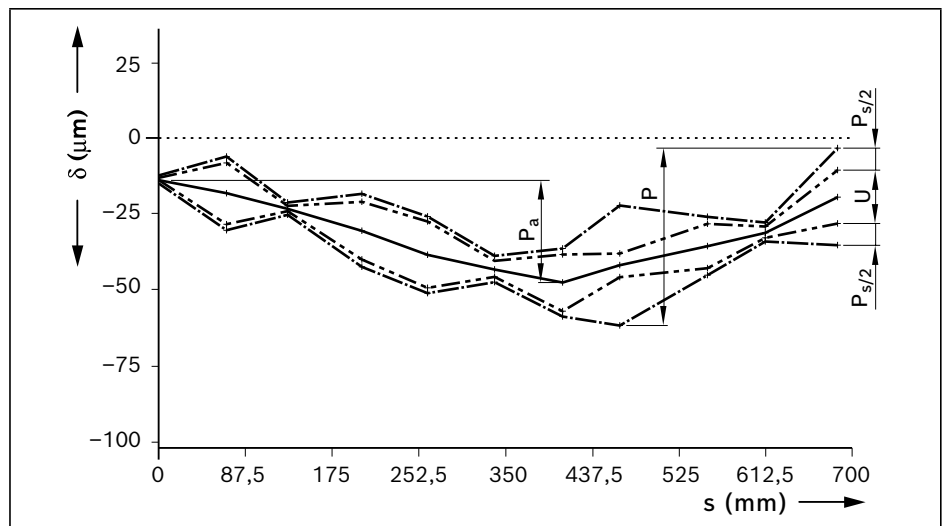

Positioning accuracy P

The positioning accuracy corresponds to the total deviation. It encompasses all the systematic and random deviations during positioning. The positioning accuracy takes the following characteristic values into consideration:

Position deviation P_a

The position deviation corresponds to the maximum difference arising in the mean values of all the measurement points. It describes systematic deviations.

Reversal range U

The reversal range corresponds to the difference in mean values of the two approach directions. The reversal range is determined at every measurement point. It describes systematic deviations.

Position variation range P_s

The position variation range describes the effects of random deviations. It is determined at every measurement point.

Ordering Example for PSK-090

Ordering data		Description
Precision Module	PSK-090-NN-2	Precision Module PSK-090-NN-2
Accuracy class	P	Precision class
Length	540	Precision Module length L = 540 mm
Reference edge	R	Right side reference edge
Lubrication	LSS	Lubrication version LSS
Cover	0	Without cover
Drive unit	16x10	Ball Screw Assembly 16x10
Carriage		
Length	S	Carriage length, standard
Number	1	1 carriage
Carriage center-to-center distance L_w ¹⁾	–	–
Version	F001	With mount and coupling
Mounting interface		
Gear ratio	i = 1	Gear ratio i = 1
Mechanical interface	MS2N03-D	Motor attachment
Motor		
Motor code	MS2N03-D0BYN	Motor type
Connection	1	Motor connection (1 cable)
Brake	Y	With holding brake
Motor connector position	090	Motor connector position = 90°
Switching system		
Sensor 1	120	PNP NC
Sensor 2	120	PNP NC
Sensor 3	120	PNP NC
Sensor mounting	001	With mounting duct, with switching cam
Documentation	001	Standard report

1) Only required for two carriages

Inquiry/Order Form

Ordering data		Customer information
Precision Module		
Accuracy class		
Length		
Reference edge		
Lubrication		
Cover		
Drive		
Carriage		
Length		
Number		
Carriage center-to-center distance Lw ¹⁾		
Version		
Mounting interface²⁾		
Gear ratio		
Mechanical interface		
Motor		
Motor code		
Connection		
Brake		
Motor connector position		
Switching system		
Sensor 1		
Sensor 2		
Sensor 3		
Sensor mounting		
Documentation		

1) Only required for two carriages

2) The motor geometry code is required for motors according to customer specifications

Motor attachment kits according to customer specification (motor geometry code)

The dimensions queried result in a unique “motor geometry code”:

□ □ - □ □ - □ □ □ - □ □ □ - □ □ □ - □ □ □ - □ □ □ - □ □ □

∅D = Shaft diameter

C = Shaft length

∅E = Centering diameter

C₁ = Centering depth

∅F = Pitch diameter

∅G = Drill hole for mounting screw (specify thread diameter)

B₁ = Flange thickness

A = Flange edge dimension

Quantity

Comments: Acceptance of: _____ pcs, _____ per month, _____ per year, per order, or _____

From

Company: _____ Name: _____
 Address: _____ Department: _____
 _____ Telephone: _____
 _____ Telefax: _____

Further Information

Bosch Rexroth Linear Motion Technology homepage:

<https://www.boschrexroth.com/en/us/products/product-groups/linear-motion-technology/index>

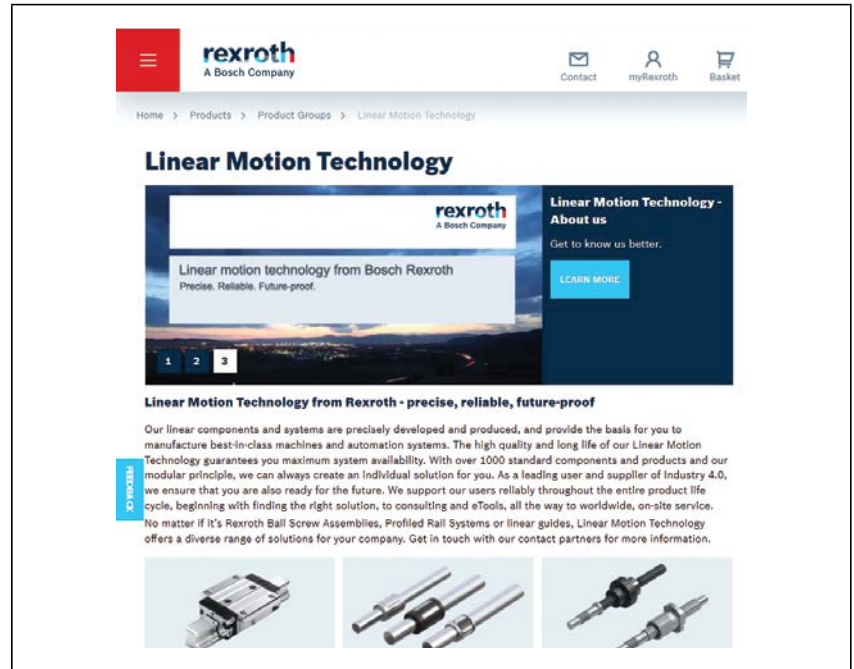
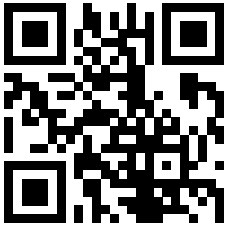

Configurators

<https://www.boschrexroth.com/ics/ref/config?matno=PSK-XXX-NN-2&language=en>

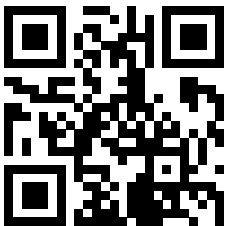

PSK-050

<https://www.boschrexroth.com/ics/ref/config?matno=R146520010&language=en>

PSK-060

<https://www.boschrexroth.com/ics/ref/config?matno=R146530010&language=en>

PSK-090

<https://www.boschrexroth.com/ics/ref/config?matno=R146540010&language=en>

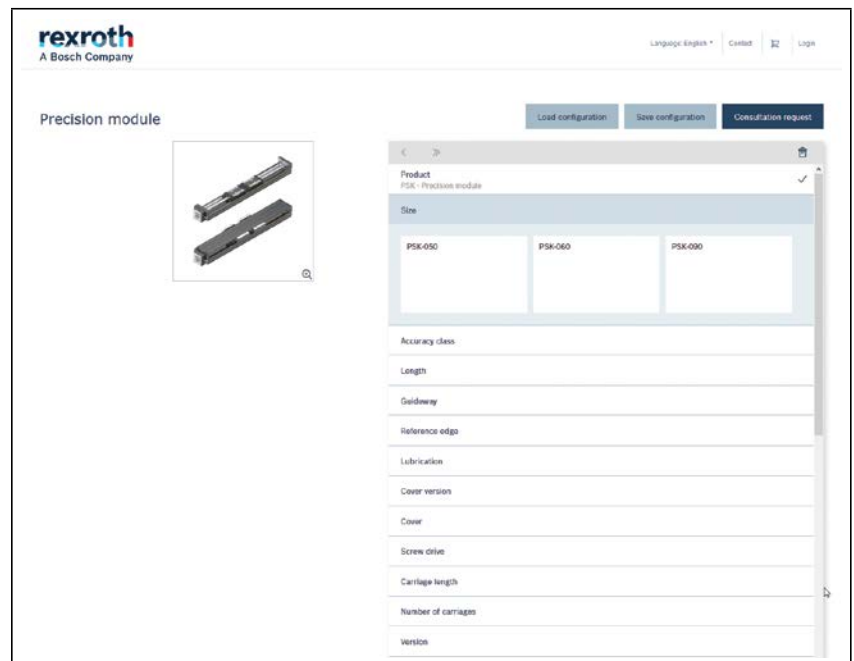

Abbreviations

Abbreviations for Linear Motion Systems

Code/index	Designation	Unit
a	Acceleration	(m/s ²)
a_{max}	Max. acceleration	(m/s ²)
Ball Screw Assembly	Ball screw assembly	(–)
B_t	Belt type	(–)
c_{spe}	Specific spring rate	(N)
C	Dynamic load capacity for guideway	(N)
C_{bs}	Dynamic load capacity for ball screw assembly	(N)
C_{fb}	Dynamic load capacity for fixed bearing	(N)
d₀	Ball screw assembly nominal diameter	(mm)
d₃	Belt pulley diameter	(mm)
f_w	Load factor	(–)
F₁, F₂, ... F_n	Axial load during phases 1 ... n	(N)
F_{bp}	Max. belt operating force	(N)
F_{comb}	Combined equivalent load on bearing	(N)
F_m	Equivalent dynamic axial load	(N)
F_{pr}	Preload force on motor	(N)
F_{t perm}	Belt elasticity limit	(N)
F_y	Load from a resulting force in y-direction	(N)
F_{y max}	Max. dynamic load in y-direction	(N)
F_z	Load from a resulting force in z-direction	(N)
F_{z max}	Max. dynamic load in z-direction	(N)
g	Gravity (= 9.81)	(m/s ²)
i	Gear ratio	(–)
I_y	Planar moment of inertia about the y-axis	
I_z	Planar moment of inertia about the z-axis	
J_{br}	Mass moment of inertia of motor brake	(kgm ²)
J_c	Mass moment of inertia of coupling	(kgm ²)
J_{dc}	Mass moment of inertia of drive train	(kgm ²)
J_{ex}	Mass moment of inertia of mechanical group	(kgm ²)
J_{ge}	Mass moment of inertia of gearbox about the motor journal	(kgm ²)
J_m	Mass moment of inertia of motor	(kgm ²)
J_s	Mass moment of inertia of Linear Motion System	(kgm ²)
J_{sd}	Mass moment of inertia of belt timing belt side drive at the motor journal	(kgm ²)
J_t	Translatory mass moment of inertia of external load about the Linear Motion System screw journal	(kgm ²)

Code/index	Designation	Unit
k_{g fix}	Constant for fixed portion of mass	(kg)
k_{g var}	Constant for variable-length portion of mass	(kg/mm)
k_{J fix}	Constant for fixed portion of mass moment of inertia	(kgmm ²)
k_{J m}	Constant for mass-specific portion of mass moment of inertia	(mm ²)
k_{J var}	Constant for variable-length portion of mass moment of inertia	(kgmm)
L	Length of Linear Motion System	(mm)
L	Nominal life – in revolutions – in meters	(rpm) (m)
L_{ad}	Length allowance	(mm)
L_{ca}	Carriage length	(mm)
L_h	Nominal life	(h)
L_m	Length of motor	(mm)
L_{max}	Max. length	(mm)
L_W	Center-to-center distance between carriage	(mm)
m_{br}	Holding brake mass	(kg)
m_{ca}	Moved system mass of carriage	(kg)
m_{ex}	Moved external mass	(kg)
m_{fc}	Mass of mount and coupling	(kg)
m_m	Motor mass	(kg)
m_s	Mass of Linear Motion System (without attachments)	(kg)
m_{sd}	Mass of timing belt side drive	(kg)
M₀	Continuous motor torque	(Nm)
M_{cN}	Nominal coupling torque	(Nm)
M_g	Torque at motor journal	(Nm)
M_{ge}	Max. permissible acceleration torque of gearbox (at output)	(Nm)
M_L	Dynamic longitudinal moment load capacity	(Nm)
M_m	Equivalent dynamic torque	(Nm)
M_{max}	Max. possible motor torque	(Nm)
M_{mech}	Max. permissible drive torque for mechanical group	(Nm)
M_p	Max. permissible drive torque (at drive journal)	(Nm)
M_R	Friction moment at motor journal	(Nm)
M_{Rge}	Friction moment of gearbox at motor journal	(Nm)
M_{Rs}	Friction moment of system	(Nm)

Code/index	Designation	Unit
M_{Rsd}	Friction moment of timing belt side drive at motor journal	(Nm)
M_{sd}	Max. permissible drive torque of timing belt side drive	(Nm)
M_{stat}	Static load torque	(Nm)
M_t	Dynamic torsional moment load capacity	(Nm)
M_x	Dynamic torsional moment about the x-axis	(Nm)
$M_{x\ max}$	Max. permissible torsional moment about the x-axis	(Nm)
M_y	Dynamic torsional moment about the y-axis	(Nm)
$M_{y\ max}$	Max. permissible torsional moment about the y-axis	(Nm)
M_z	Dynamic torsional moment about the z-axis	(Nm)
$M_{z\ max}$	Max. permissible torsional moment about the z-axis	(Nm)
n_1, n_2, \dots, n_n	Speed in acceleration and braking phases	(rpm)
$n_{A1 \dots n}$	Starting speed in Phase 1 ... n	(rpm)
$n_{E1 \dots n}$	Ending speed in Phase 1 ... n	(rpm)
n_{ge}	Max. permissible speed of gearbox	(rpm)
n_m	Mean speed	(rpm)
n_{mech}	Max. permissible speed of mechanical group	(rpm)
n_{max}	Max. motor speed	(rpm)
n_p	Max. permissible speed of Linear Motion System	(rpm)
P	Screw lead	(mm)
P_{app}	Effective power in application	(W)
Keyway	Keyway	(-)
s_a	Acceleration travel	(mm)
s_e	Excess travel (excess travel s_e should be greater than breaking distance. The acceleration travel can be used as a guideline for braking distance.)	(mm)
s_{eff}	Effective stroke	(mm)
s_{min}	Min. travel distance	(mm)
s_{max}	Max. travel distance	(mm)
Screw support	Screw support	
t_a	Acceleration time, braking time	(s)
t_1, t_2, \dots, t_n	Time for Phase 1 ... n	(s)
u	Lead constant	(mm/rev)

Code/index	Designation	Unit
v_1, v_2, \dots, v_n	Velocity in Phase 1 ... n	(m/s)
v_{max}	Max. permissible velocity	(m/s)
v_{mech}	Max. permissible velocity of mechanical group	(m/s)
v_m	Mean velocity	(m/s)
V	Ratio of mass moments of inertia from drive train and motor	(-)
z_1	Working point of acting force	(mm)
π	Pi	(-)

Bosch Rexroth Corporation

Corporate Headquarters
14001 South Lakes Drive
Charlotte, NC 28273
Telephone (800) REXROTH
(900) 739-7684
info@boschrexroth-us.com
www.boschrexroth-us.com

Find your local contact person here:

www.boschrexroth-us.com/contactus

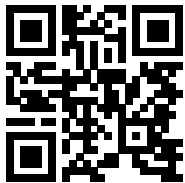

248-373-1600 • morrell-group.com • orders@morrellinc.com

MI • IN • IL • OH • ON, CAN

