

4 PLCS Mounting Hole
M4 Tap 6mm Deep

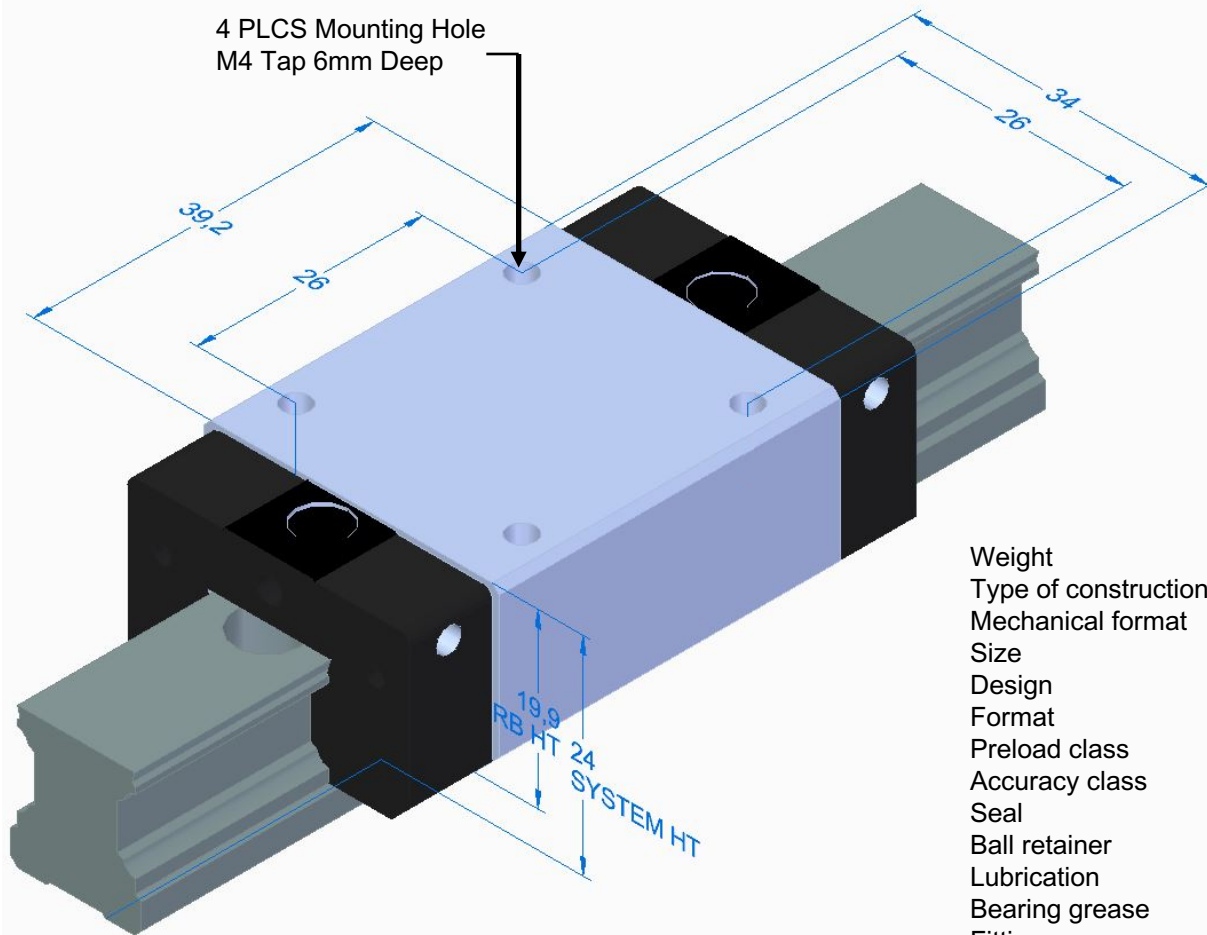

Weight	0.15 kg
Type of construction	FW runner block
Mechanical format	KWD Ball runner block
Size	15
Design	SNS Slimline, normal, standard height
Format	CS Carbon steel
Preload class	C1 low preload
Accuracy class	N Normal
Seal	SS Standard seal
Ball retainer	0 Without ball retainer
Lubrication	01 Prelubricated, preserved
Bearing grease	S1 Dynalub 510
Fitting	M4X6

10 MILLION METER RELUBRICATION SCHEDULE

RATINGS

	<u>ENGLISH</u>
9,860 N Basic Dynamic Capacity	2220 lbs
12,700 N Static Capacity	2855 lbs
95 Nm Roll Moment Dynamic Capacity	70 ft-lbs
120 Nm Roll Moment Static Capacity	88 ft-lbs
68 Nm Pitch/Yaw Moment Dynamic Capacity	50 ft-lbs
87 Nm Pitch/Yaw Moment Static Capacity	64 ft-lbs

Bosch Rexroth BSHP Ball Rail Runner Block
KWD-015-SNS-CS-C1-N-SS-0-01-S1-00-BX-LS-000-RS-000-01
PN: 1622-114-20



www.morrell-group.com



UNITS : mm