

4 PLCS Mounting Hole
M6 Tap 9mm Deep

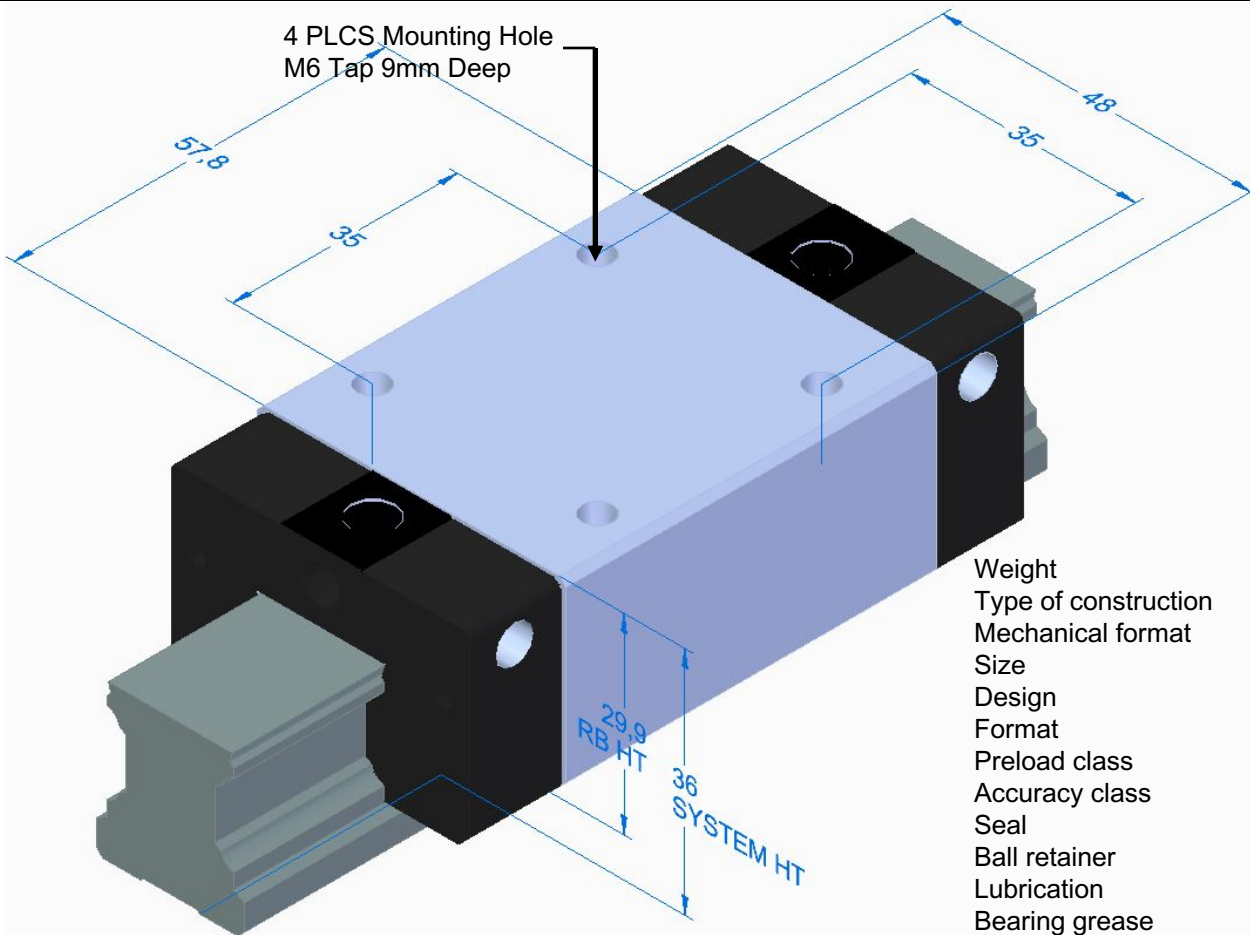

Weight	0.50 kg
Type of construction	FW runner block
Mechanical format	KWD Ball runner block
Size	25
Design	SNS Flanged, normal, standard height
Format	CS Carbon steel
Preload class	C1 low preload
Accuracy class	N Normal
Seal	SS Standard seal
Ball retainer	0 Without ball retainer
Lubrication	01 Prelubricated, preserved
Bearing grease	S1 Dynalub 510
Fitting	M6X9

10 MILLION METER RELUBRICATION SCHEDULE

<u>RATINGS</u>		<u>ENGLISH</u>	
28,600 N	Basic Dynamic Capacity	6530	lbs
35,900 N	Static Capacity	8071	lbs
410 Nm	Roll Moment Dynamic Capacity	302	ft-lbs
510 Nm	Roll Moment Static Capacity	346	ft-lbs
290 Nm	Pitch/Yaw Moment Dynamic Capacity	214	ft-lbs
360 Nm	Pitch/Yaw Moment Static Capacity	266	ft-lbs

Bosch Rexroth BSHP Ball Rail Runner Block
KWD-025-SNS-CS-C1-N-SS-0-01-S1-00-BX-LS-000-RS-000-01
PN: 1622-214-20

MorrellGroup
Evolution in Controls

www.morrell-group.com

rexroth
A Bosch Company

UNITS : mm