

4 PLCS Mounting Hole  
M5 Tap 7.5mm Deep

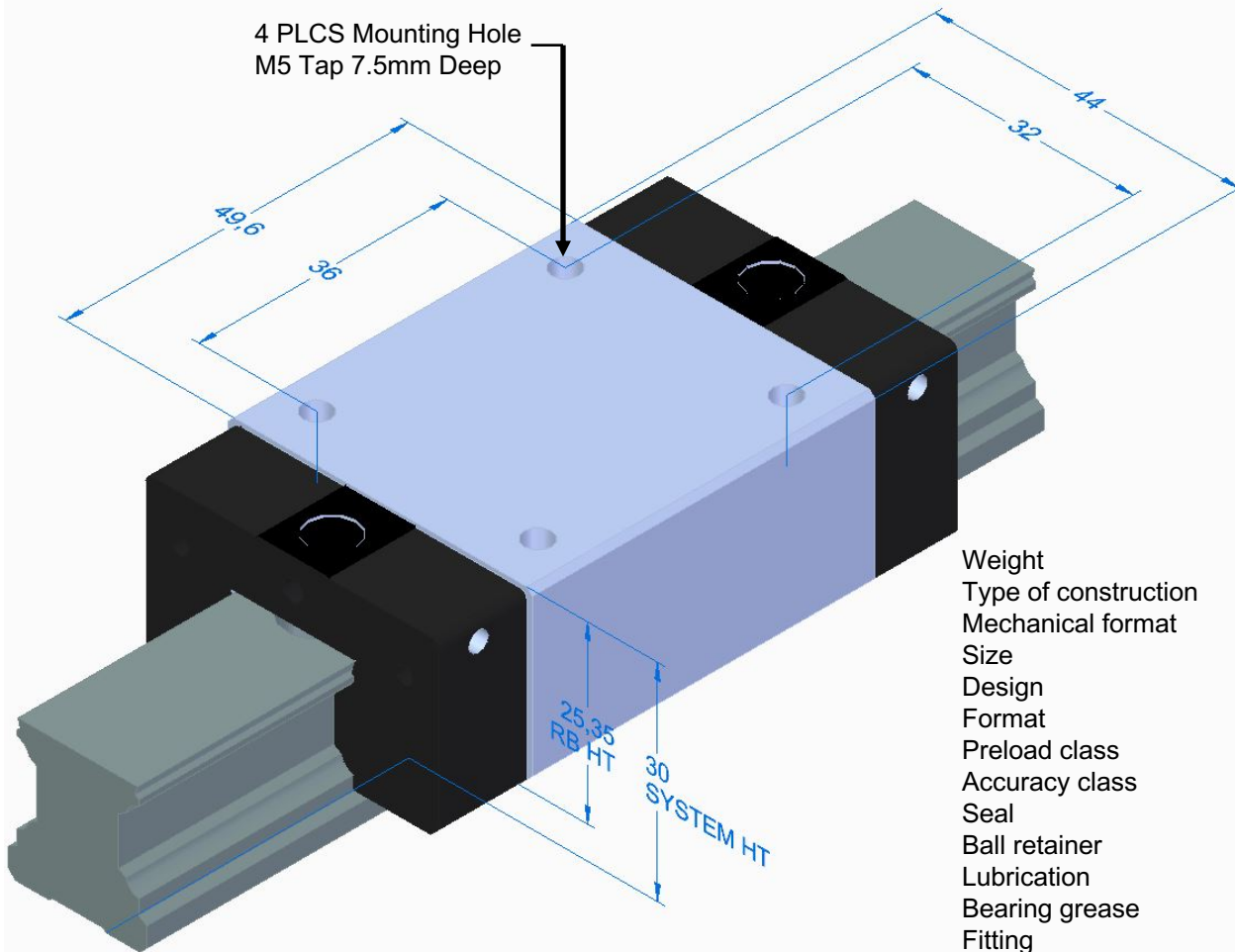

Weight	0.35 kg
Type of construction	FW runner block
Mechanical format	KWD Ball runner block
Size	20
Design	SNS Flanged, normal, standard height
Format	CS Carbon steel
Preload class	C1 low preload
Accuracy class	N Normal
Seal	SS Standard seal
Ball retainer	0 Without ball retainer
Lubrication	01 Prelubricated, preserved
Bearing grease	S1 Dynalub 510
Fitting	M5X7.5

### 10 MILLION METER RELUBRICATION SCHEDULE

<u>RATINGS</u>	<u>ENGLISH</u>
23,400 N Basic Dynamic Capacity	5,260 lbs
29,800 N Static Capacity	6,700 lbs
300 Nm Roll Moment Dynamic Capacity	221 ft-lbs
380 Nm Roll Moment Static Capacity	280 ft-lbs
200 Nm Pitch/Yaw Moment Dynamic Capacity	147 ft-lbs
260 Nm Pitch/Yaw Moment Static Capacity	192 ft-lbs

Bosch Rexroth BSHP Ball Rail Runner Block  
KWD-020-SNS-CS-C1-N-SS-0-01-S1-00-BX-LS-000-RS-000-01  
**PN: 1622-894-20**

**MorrellGroup**  
Evolution in Controls

[www.morrell-group.com](http://www.morrell-group.com)

**rexroth**  
A Bosch Company

UNITS : mm