

4 PLCS Mounting Hole  
Either M10 Tap Or Can Be Used as  
Thru Hole for M8 Nut and Bolt

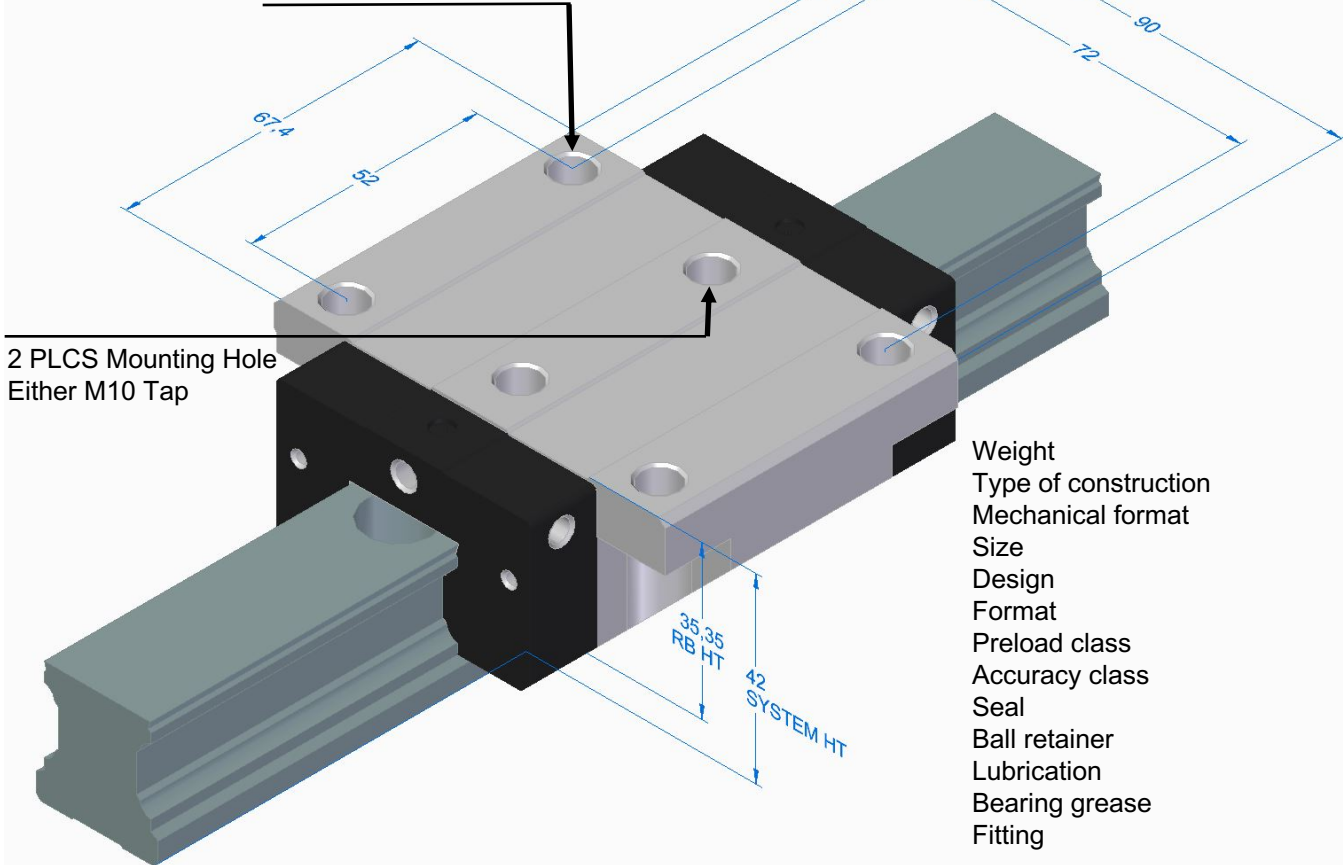

2 PLCS Mounting Hole  
Either M10 Tap



Weight	1.10 kg
Type of construction	FW runner block
Mechanical format	KWD Ball runner block
Size	30
Design	FNS Flanged, normal, standard height
Format	CS Carbon steel
Preload class	C1 low preload
Accuracy class	N Normal
Seal	SS Standard seal
Ball retainer	0 Without ball retainer
Lubrication	01 Prelubricated, preserved
Bearing grease	S1 Dynalub 510
Fitting	M6X8

**10 MILLION METER RELUBRICATION SCHEDULE**

<u>RATINGS</u>	<u>ENGLISH</u>
36,500 N Basic Dynamic Capacity	8,205 lbs
48,100 N Static Capacity	10,813 lbs
630 Nm Roll Moment Dynamic Capacity	465 ft-lbs
830 Nm Roll Moment Static Capacity	612 ft-lbs
440 Nm Pitch/Yaw Moment Dynamic Capacity	325 ft-lbs
580 Nm Pitch/Yaw Moment Static Capacity	428 ft-lbs

Bosch Rexroth BSHP Ball Rail Runner Block  
KWD-030-FNS-CS-C1-N-SS-0-01-S1-00-BX-LS-000-RS-000-01

**PN: 1651-714-20**

 <p><a href="http://www.morrell-group.com">www.morrell-group.com</a></p>	
	<p>UNITS : mm</p>