

6 PLCS Mounting Hole
M8 Tap 9.35mm Deep

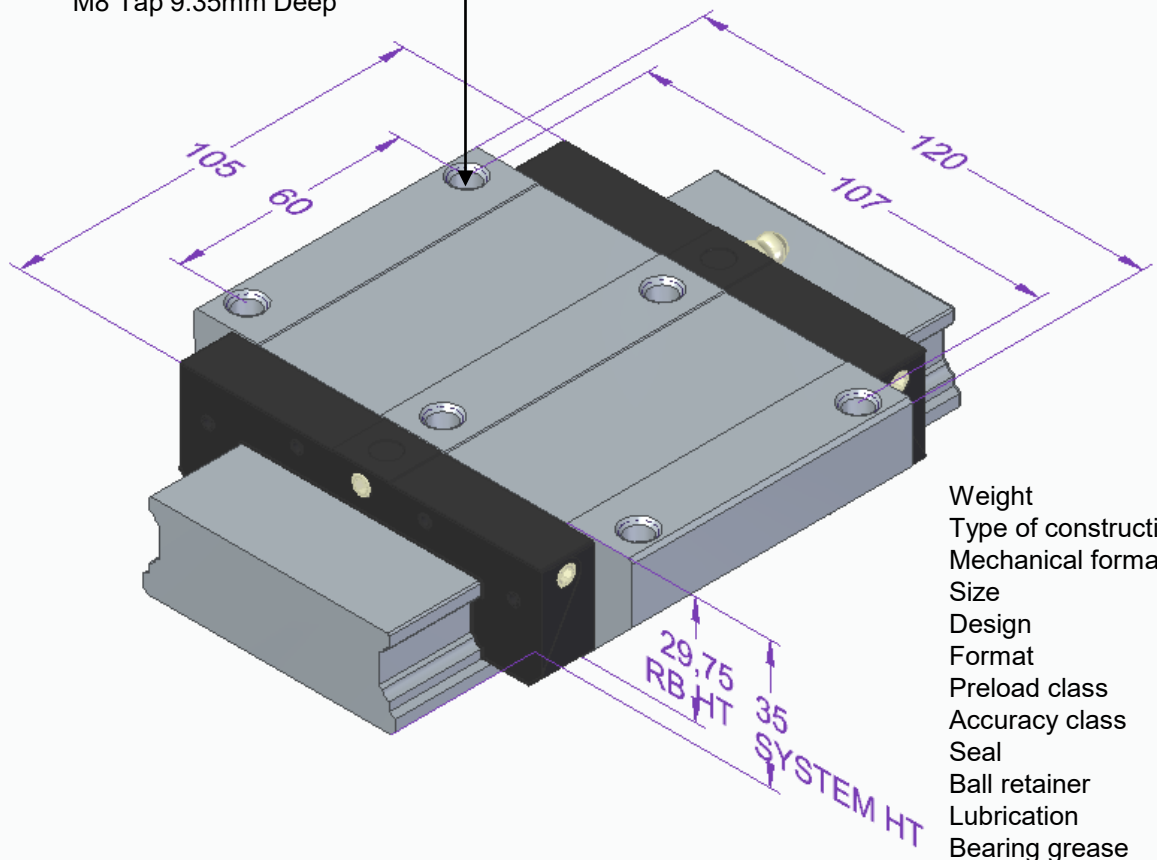

 **Low Drag Runner Block Version**
No End Seals – Oil Preserved



Weight	1.20 kg
Type of construction	FW runner block
Mechanical format	KWD Ball runner block
Size	25/70
Design	BNS Wide, normal, standard height
Format	CS Carbon steel
Preload class	C0 – 10 micron clearance
Accuracy class	N Normal
Seal	LS/99 – Low Friction/No seal
Ball retainer	0 Without ball retainer
Lubrication	02 Preserved
Bearing grease	00 No Lube
Fitting	M8X9.35

10 MILLION METER RELUBRICATION SCHEDULE

<u>RATINGS</u>	<u>ENGLISH</u>
36,200 N Basic Dynamic Capacity	26,700 lbs
50,200 N Static Capacity	37,025 lbs
1,350 Nm Roll Moment Dynamic Capacity	995 ft-lbs
1,870 Nm Roll Moment Static Capacity	1,380 ft-lbs
490 Nm Pitch/Yaw Moment Dynamic Capacity	361 ft-lbs
680 Nm Pitch/Yaw Moment Static Capacity	501 ft-lbs

Bosch Rexroth BSHP Ball Rail Runner Block
KWD-025-BNS-CS-C0-N-LS/99-0-02-00-BX-LS-000-RS-000-01
PN: 1671-294-25_R030101333_LD  **Low Drag**



UNITS : mm

www.morrell-group.com