

## Backflushing Filter AutoFilt® RF5



RF5 - 25

RF5 - 50

RF5 - 90



### 1. TECHNICAL SPECIFICATIONS

#### 1.1 GENERAL

The AutoFilt® RF5 is a self cleaning system for extracting particles from low viscosity fluids. Its robust construction and automatic backflushing capability make a major contribution to operational reliability and **reduce operating and maintenance costs.**

The slotted tube elements in the filter with **filtration rates from 200 to 3000 µm** ensure highly effective filtration of contaminating particles from the process medium.

Automatic cleaning starts as soon as the elements become contaminated. **The flow of filtrate is not interrupted during the backflushing procedure.**

A range of filters of different sizes allow **flow rates of up to 4200 m³ per hour.**

**Numerous combinations of materials and equipment** as well as **individually adjustable control parameters** allow optimum adaptation of the filter to any application.

#### 1.2 OPERATION OF THE AUTOFILT® RF5 Filtration

The fluid to be filtered flows through the slotted tube filter elements of the backflushing filter, passing from the inside to the outside.

Contamination particles then collect on the smooth inside of the filter elements.

As the level of contamination increases, the differential pressure between the contaminated and clean sides of the filter increases.

When the differential pressure reaches its pre set value, backflushing starts automatically.

#### Filtration

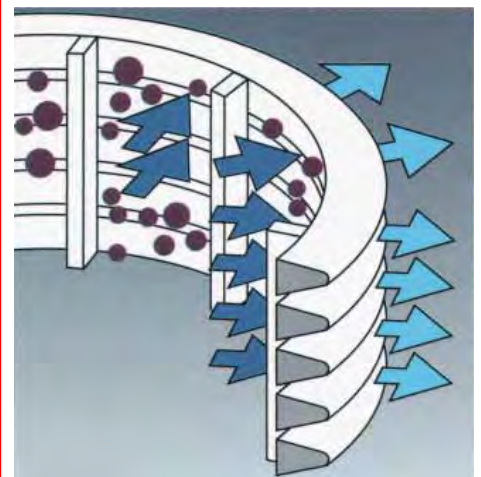
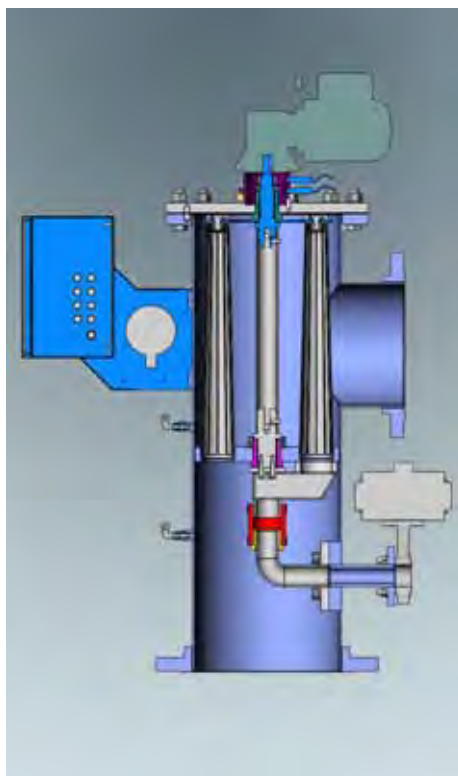
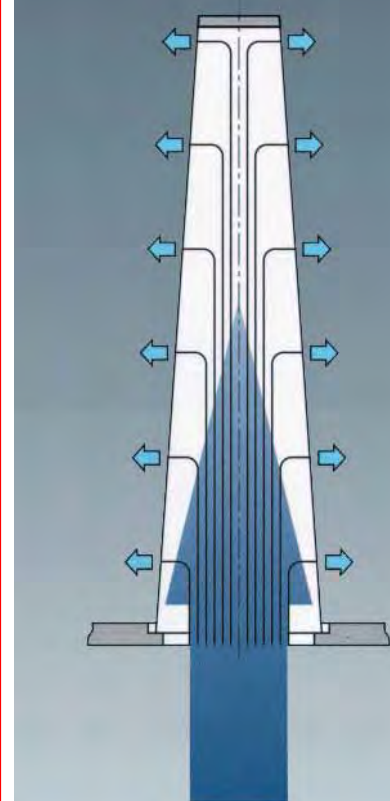

### Triggering automatic backflushing

Backflushing is triggered automatically:

- When the triggering differential pressure is exceeded
- By means of an adjustable timer (optional)
- By pressing the TEST key

As soon as backflushing has been triggered, the filter starts to clean the filter elements.

### Backflushing of the filter elements - backflushing cycle

Type of control:

- EPZ: Electro-pneumatic cyclic control. The pneumatic backflushing valve opens, the gear motor rotates the rinsing arm continuously under and past the filter elements to be cleaned. The pressure drop between the filtrate side and the backflushing line rinses a minimal partial flow of the filtrate in the opposite direction, into the filter elements to be cleaned. The contamination particles deposited on the inside of the filter elements are detached and carried out via the rinsing arm into the backflushing line. Once the set backflushing time period has ended, the drive motor stops and the backflushing valve is closed.
- EZ: Electrical cyclic control. Like EPZ, but with an electrical backflushing valve.
- EPT: Electro-pneumatic cyclic control. The gear motor rotates the rinsing arm under the filter elements to be cleaned and stops. The backflushing valve is opened and this or the elements are cleaned due to the pressure drop between the filtrate side and the backflushing line. After the "backflushing time per element" has ended, the backflushing valve is closed. The gear motor then rotates the arm further to the next filter elements to be cleaned. The backflushing valve is opened again and the filter elements are backflushed. The complete backflushing cycle is ended once all filter elements have been cleaned.
- PT: Pneumatic cyclic control: Like EPT, but with purely pneumatic components.
- PTZ: Pneumatic cyclic control with timer function. Like PT, but a maximum filtration time can be set, independent of the differential pressure, between two backflushing cycles.

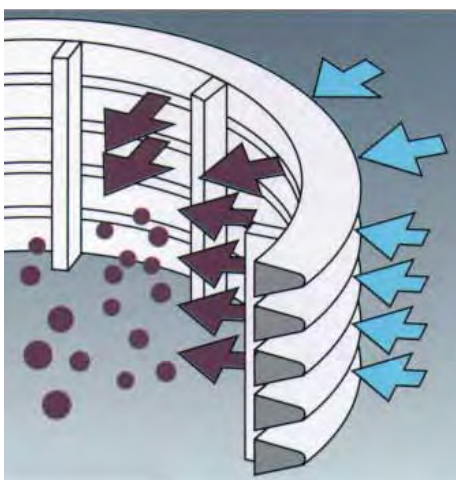
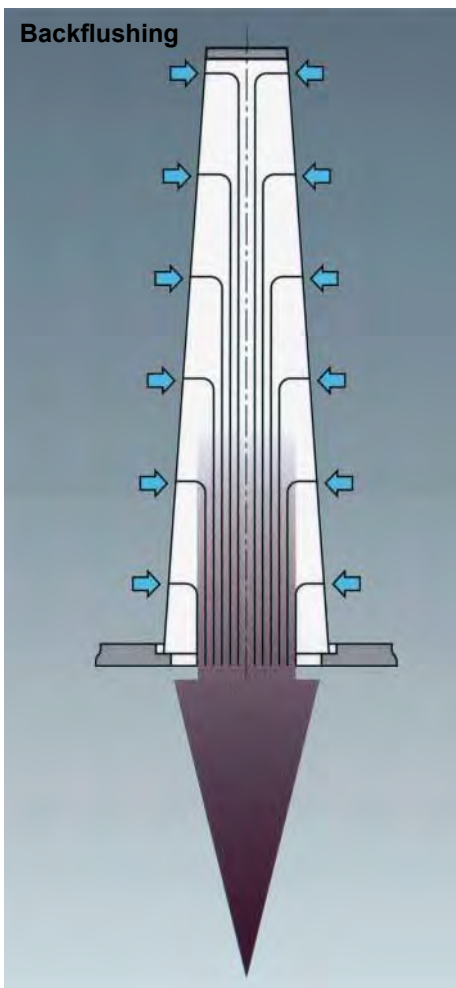

### 1.3 SPECIAL FEATURES OF THE AUTOFILT® RF5

- High flow rates with compact construction
- Pressure drop optimised
- Conical filter elements
- Filtration rating 200 – 3000 µm

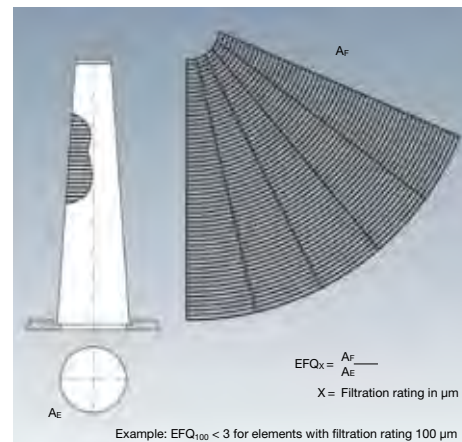

### Element opening quotient $EFQ_x$

The element opening quotient ( $EFQ_x$ ) is decisive for an even and tailback free flow through the filter element during filtering and backflushing. The  $EFQ_x$  value is the ratio open filter surface of an element to opening cross-section on the element inlet.

## 2. FILTER SPECIFICATIONS

### 2.1. STANDARD CONFIGURATIONS

#### 2.1.1 Control parameters

- EPZ: electro-pneumatic cyclic control
- EZ: electrical cyclic control
- EPT: electro-pneumatic cyclic control
- PT: pneumatic cyclic control
- PTZ: pneumatic cyclic control with timer function

#### 2.1.2 Connection voltages

- 3 x 400V / 50 Hz with or without neutral wire
- 3 x 500V / 50 Hz without neutral wire
- 3 x 230V / 50 Hz with or without neutral wire
- 3 x 415V / 50 Hz without neutral wire
- 3 x 415V / 60 Hz without neutral wire
- 3 x 460V / 60 Hz without neutral wire
- Others available on request

#### 2.1.3 Flange connections

- DIN / ANSI / JIS

#### 2.1.4 Housing materials

- Carbon steel
- Stainless steel

#### 2.1.5 Material of internal parts

- Stainless steel 1.4301

#### 2.1.6 Material of elements

- Stainless steel 1.4435, 1.4404

#### 2.1.7 External corrosion protection

- 2-coat primer (not required for stainless steel housing)

#### 2.1.8 Internal corrosion protection

- Epoxy coating
- Polyurethane coating

#### 2.1.9 Differential pressure gauge

- Aluminium
- Stainless steel
- Brass

#### 2.1.10 Filtration ratings

- 200 µm to 3000 µm slotted tube

#### 2.1.11 Electrical protection class

- IP55

#### 2.1.12 Pressure ranges

- 10 bar or 6 bar depending on size

#### 2.1.13 Operating temperature

- Max. operating temperature 90 °C

### 2.2. OPTIONAL VERSIONS

There are a range of optional versions available for the AutoFilt® RF5. For technical details and prices, please contact our Technical Sales Department at Head Office.

#### 2.2.1 Control /electrical components / voltage supply

- PLC control
- Filter without control for integration into customer's PLC
- Filter interlocking for parallel operation
- UL/CSA approved controls and components
- Special IP protection classes
- Safe in tropical conditions
- Customised special solutions

#### 2.2.2 Housing manufacture

- ASME Code design
- U-stamp

#### 2.2.3 Flange connections

- ANSI
- JIS

#### 2.2.4 Housing materials

- Duplex
- Superduplex
- Various qualities of stainless steel
- Various qualities of carbon steel

#### 2.2.5 Materials of internal parts and elements

- Duplex
- Superduplex
- Various qualities of stainless steel
- Superflush element technology

#### 2.2.6 External corrosion protection

- Multiple layer coatings
- Special paints / coatings for offshore use
- Special paints / coatings according to customer specifications
- Colours to customer specification

#### 2.2.7 Internal corrosion protection

- Glass flake lining
- Special paint/coatings according to customer specifications

#### 2.2.8 Explosion protection

- ATEX according to Directive 94/9/EC

#### 2.2.9 Documentation

- Manufacturer's test certificates
- Material certificates 3.1
- GOST certificate
- 3rd parties (TÜV, ABS, Lloyds, etc.)
- WPS / PQR
- Inspection plan

And many others available on request

## 2.3 OVERVIEW OF TECHNICAL SPECIFICATIONS OF STANDARD MODELS

| Filter Size | Pressure range [bar] | Connection <sup>1)</sup> Inlet | Connection <sup>1)</sup> Outlet | Connection back-flushing line 1 | Weight <sup>2)</sup> [kg] | Volume [l] | No. of elements | Filtration area [cm <sup>2</sup> ] | Backflush volume <sup>3)</sup> [l] |
|-------------|----------------------|--------------------------------|---------------------------------|---------------------------------|---------------------------|------------|-----------------|------------------------------------|------------------------------------|
| 25          | 10                   | DN 250                         | DN 200                          | DN 40                           | 140                       | 54         | 6 x E1          | 6120                               | 35                                 |
| 30          | 10                   | DN 300                         | DN 250                          | DN 40                           | 170                       | 83         | 8 x E1          | 8160                               | 47                                 |
| 40          | 6                    | DN 400                         | DN 300                          | DN 65                           | 285                       | 212        | 6 x E2          | 16920                              | 63                                 |
| 50          | 6                    | DN 500                         | DN 400                          | DN 65                           | 450                       | 320        | 9 x E2          | 25380                              | 95                                 |
| 60          | 6                    | DN 600                         | DN 500                          | DN 80                           | 615                       | 480        | 18 x E2         | 50760                              | 233                                |
| 70          | 6                    | DN 700                         | DN 600                          | DN 80                           | 945                       | 780        | 21 x E3         | 70980                              | 271                                |
| 90          | 6                    | DN 900                         | DN 800                          | DN 100                          | 1515                      | 1370       | 35 x E3         | 118300                             | 606                                |

**Max. permissible temperature for all AutoFilt® RF5: 90 °C**

- 1) According to DIN/EN standard / reservoir manufacture to AD2000, application of Pressure Equipment Directive 97/23/EC if required
- 2) Approx. empty weight based on standard pressure range
- 3) Based on EPT/PT control mode with opening time of backflushing valve of 1.5 seconds and 1.5 bar differential pressure between outlet and backflushing line, with EU control the backflushing volume increases by a factor of 5.

## 2.4 CIRCUIT DIAGRAM

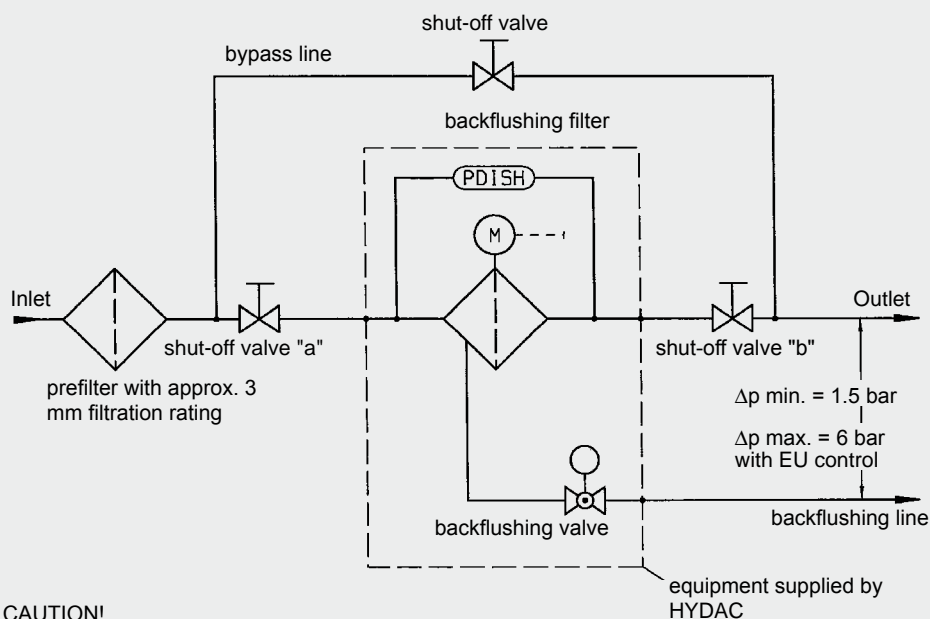

**CAUTION!**  
For cleaning, there must be a minimum pressure difference between the outlet and the backflushing line of 1.5 bar.

### 3. MODEL CODE AUTOFILT® RF5

RF5 - 25 - EPT - N - N - 2 - 1 - 1 / ES200 - 25 - 12345678

#### Type AutoFilt®

#### Size / filter inlet - filter outlet

|    |                 |      |
|----|-----------------|------|
| 25 | = DN250 - DN200 | PN10 |
| 30 | = DN300 - DN250 | PN10 |
| 40 | = DN400 - DN300 | PN6  |
| 50 | = DN500 - DN400 | PN6  |
| 60 | = DN600 - DN500 | PN6  |
| 70 | = DN700 - DN600 | PN6  |
| 90 | = DN900 - DN800 | PN6  |

#### Type of control / Input supply voltage

|     |  |
|-----|--|
| EPZ | = electro-pneumatic cyclic control                   |
| EZ  | = electrical control                                 |
| EPT | = electro-pneumatic cyclic control                   |
| PT  | = pneumatic cyclic control                           |
| PTZ | = pneumatic cyclic control with timer function       |
| 0   | = without control, all users on terminal strip/block |
| 1   | = 3 x 400V / N / PE 50Hz                             |
| 2   | = 3 x 400V / x / PE 50Hz                             |
| 3   | = 3 x 500V / x / PE 50Hz                             |
| 4   | = 3 x 230V / N / PE 50Hz                             |
| 5   | = 3 x 230V / x / PE 50Hz                             |
| 6   | = 3 x 415V / x / PE 50Hz                             |
| 7   | = 3 x 415V / N / PE 60Hz                             |
| 8   | = 3 x 460V / x / PE 60Hz                             |
| 9   | = 3 x 440V / x / PE 60Hz                             |
| A   | = 3 x 525V / x / PE 50Hz                             |
| B   | = 3 x 575V / x / PE 60Hz                             |
| C   | = 3 x 690V / x / PE 50Hz                             |
| D   | = 1 x 230V / N / PE 50Hz                             |
| E   | = 1 x 230V / N / PE 60Hz                             |
| F   | = 1 x 115V / N / PE 60Hz                             |

#### Housing material

|    |   |
|----|---|
| N  | = carbon steel, external primer (RAL 9006)                                  |
| NM | = carbon steel, external primer (RAL 9006), 2K epoxy paint, internal        |
| NP | = carbon steel, external primer (RAL 9006), 2K polyurethane paint, internal |
| E  | = stainless steel   |
| A  | = for ANSI flanges, add A   |
| J  | = for JIS flanges, add J  |

#### Material of backflushing valve

|   |  |
|---|--|
| N | = butterfly: housing SG cast iron coated, washer stainless steel |
| B | = butterfly: housing SG cast iron coated, washer bronze          |

#### Differential pressure gauge

|   |                                    |
|---|------------------------------------|
| 1 | = pressure chamber aluminium       |
| 2 | = pressure chamber stainless steel |
| 4 | = pressure chamber brass           |

#### Control cabinet fixtures

|   |  |
|---|--|
| 1 | = Control cabinet offset by 90° clockwise to filter outlet             |
| 2 | = Control cabinet offset by 180° clockwise to filter outlet (opposite) |
| 3 | = Control cabinet offset by 270° clockwise to filter outlet            |

#### Modification number

|   |   |
|---|---|
| X | = the latest version is always supplied |
|---|---|

#### Element set

|      |  |
|------|--|
| ESx  | = conical slotted tubes (200 µm - 3000 µm) |
| SESx | = conical slotted tubes, Superflush-coated |

#### Size of element set

Identical to size of filter

#### Drawing number

For special models (number is allocated after technical clarification at Head Office)

## MODEL CODE ELEMENT SET AUTOFILT® RF5

S ES 200 - 25 - V - R

### Superflush coating

optional, appears only if selected

### Filter element

ES = conical slotted tube

### Filtration rating

ES = 200 - 3000 µm

### Size of element set (according to size of filter)

25, 30, 40, 50, 60, 70, 90

### Seal material

V = Viton

N = NBR

E = EPDM

T = FEP coated Viton seal

### End cap

R = welded on with O-ring seal

## MODEL CODE SINGLE ELEMENT AUTOFILT® RF5

S E 25 S 200 R - V

### Superflush coating

optional, appears only if selected

### Filter element

E = conical element

### Element size

25, 30, 40, 50, 60, 70, 90

### Filter material

S = slotted tube

### Filtration rating

200 - 3000 µm

### End cap

R = welded on with O-ring seal

### Seal material

V = Viton

N = NBR

E = EPDM

T = FEP coated Viton seal

## 4. FILTER CALCULATION / SIZING

### 4.1 PRESSURE DROP CURVES

The pressure drop curves apply to water.

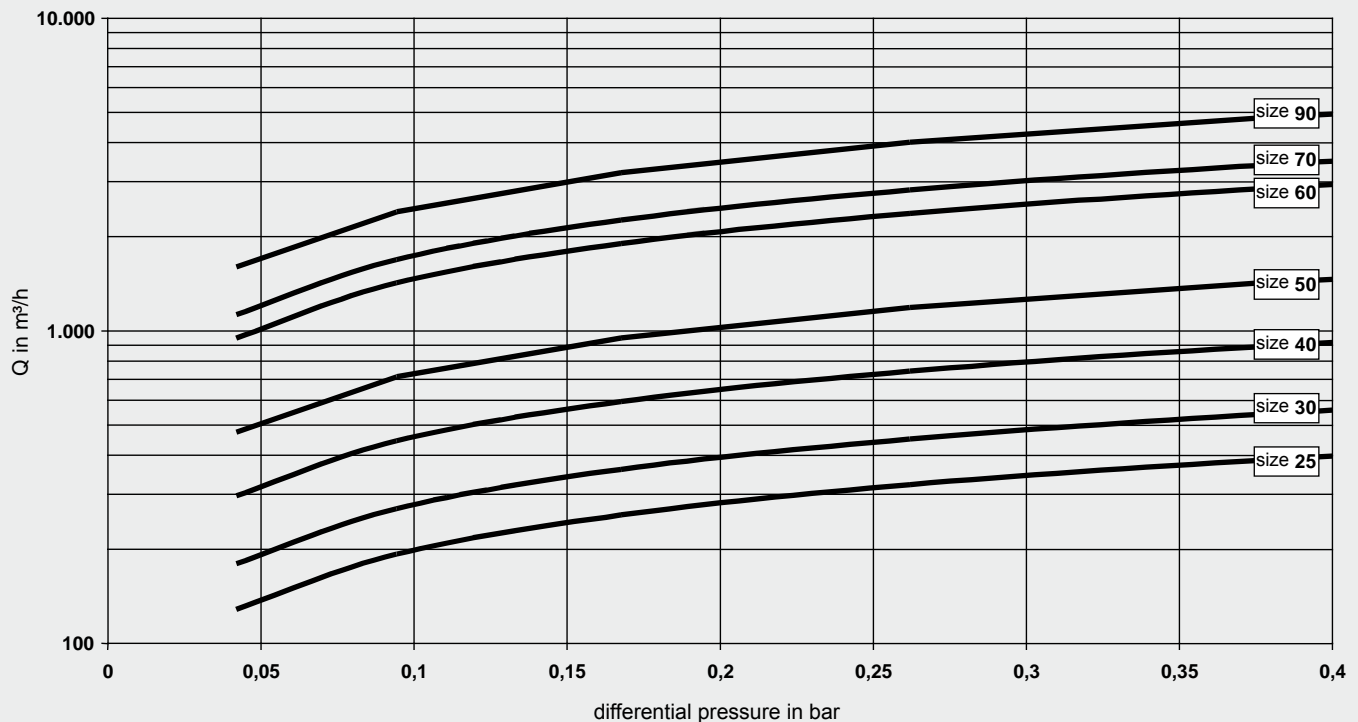

It is crucial when operating the AutoFilt® RF5 that there is a differential pressure between the backflushing line and the filter outlet of at least 1.5 bar. This minimum pressure differential ensures the operation of the filter.

In order to be able to size the filter correctly, the following design data should be available:

(see also Filter questionnaire)

- Flow rate
- Type of medium
- Materials
- Viscosity
- Required filtration rating
- Particulate loading in the fluid
- Type of contamination
- Operating pressure
- Operating temperature
- Power supply and compressed air supply
- Pressure ratios after the AutoFilt® RF5 (is there any back pressure?)
- Integration of the AutoFilt® RF5 into the whole system

The AutoFilt® RF5 is sized based on the pressure drop curve and the calculation table. Generally speaking, an initial  $\Delta p$  (clean filter condition) of 0.2 bar should not be exceeded. The pressure drop curve is valid for filtration ratings of 200 – 3000  $\mu\text{m}$  slotted tube. A further factor in the calculation is the flow velocity through the filter outlet. It should not exceed 3 m/s.

### 4.2. CALCULATION TABLES

#### 4.2.1 Water applications

The calculation tables form an important basis for selection of the AutoFilt® RF5.

| Filter Size | Flow rate range  |
|-------------|------------------|
| 25          | 170 - 320 m³/h   |
| 30          | 290 - 450 m³/h   |
| 40          | 400 - 750 m³/h   |
| 50          | 650 - 1200 m³/h  |
| 60          | 1000 - 1900 m³/h |
| 70          | 1500 - 2800 m³/h |
| 90          | 2600 - 4200 m³/h |

- The flow rate ranges given apply to filtration ratings  $\geq 200 \mu\text{m}$ .

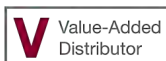

248-373-1600 • morrell-group.com • orders@morrellinc.com

MI • IN • IL • OH • ON, CAN

**MorrellGroup**  
Evolution in Controls

## 5. DIMENSIONS

The dimensions indicated relate to the standard pressure ranges.

### SIZES 25-40

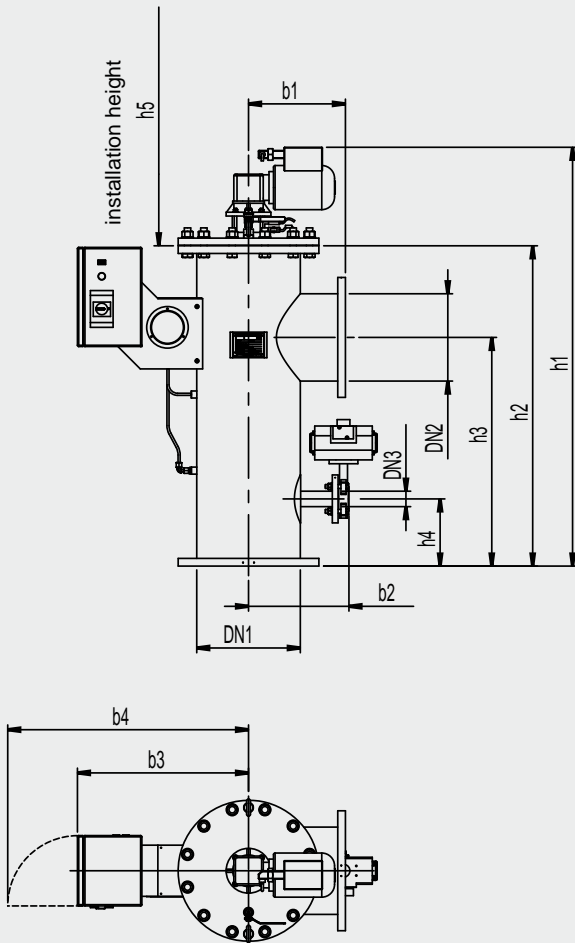

### SIZES 50-90

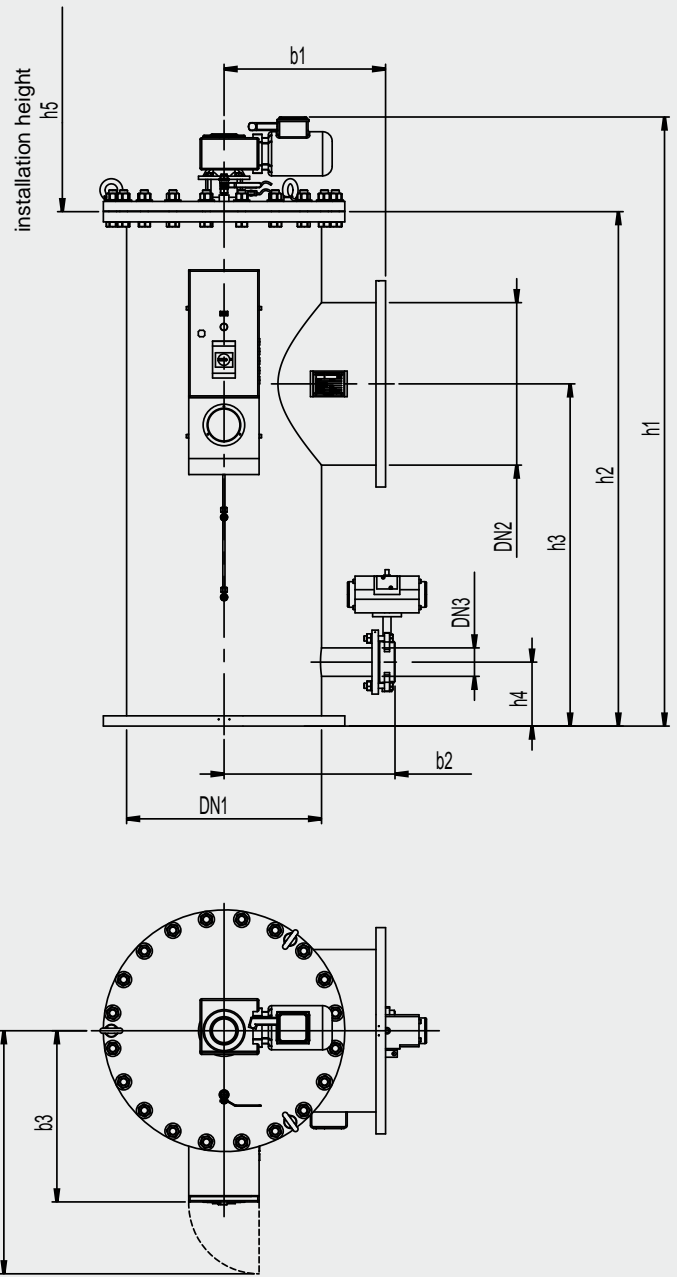

| Filter Size | DN1 | DN2 | DN3 | h1     | h2     | h3   | h4  | h5   | b1  | b2  | b3  | b4  |
|-------------|-----|-----|-----|--------|--------|------|-----|------|-----|-----|-----|-----|
| 25          | 250 | 200 | 40  | 1212.5 | 912.5  | 625  | 180 | 550  | 300 | 275 | 508 | 728 |
| 30          | 300 | 250 | 40  | 1313.5 | 1001.5 | 715  | 210 | 550  | 300 | 314 | 533 | 753 |
| 40          | 400 | 300 | 65  | 1890.5 | 1575.5 | 1030 | 180 | 1050 | 370 | 380 | 575 | 795 |
| 50          | 500 | 400 | 65  | 1888.5 | 1585.5 | 1050 | 190 | 1050 | 435 | 440 | 485 | 705 |
| 60          | 600 | 500 | 80  | 1905.5 | 1608.5 | 1070 | 200 | 1050 | 505 | 534 | 540 | 760 |
| 70          | 700 | 600 | 80  | 2238.5 | 1903.5 | 1235 | 200 | 1350 | 570 | 580 | 593 | 813 |
| 90          | 900 | 800 | 100 | 2328.5 | 1993.5 | 1325 | 225 | 1350 | 690 | 690 | 698 | 918 |

### NOTE

The information in this brochure relates to the operating conditions and applications described.  
For applications or operating conditions not described, please contact the relevant technical department.  
Subject to technical modifications.

**HYDAC** Process Technology GmbH  
Am Wrangelflöz 1  
D-66538 Neunkirchen  
Tel.: +49 (0)6897 - 509-1241  
Fax: +49 (0)6897 - 509-1278  
Internet: www.hydac.com  
E-Mail: prozess-technik@hydac.com